

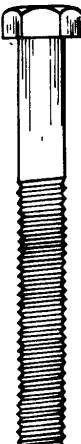

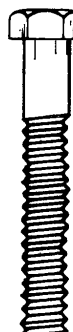

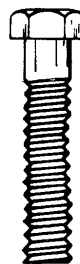





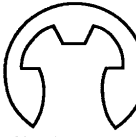





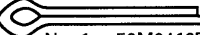



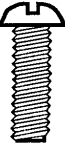

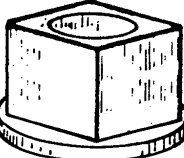

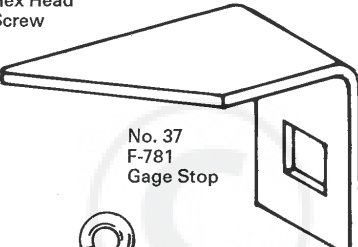

HARDWARE

 <p>No. 39 1M1044P 5/16" x 2 3/4" Hex Bolt</p>	 <p>No. 23 1M1032P 5/16" x 2" Hex Bolt</p>	 <p>No. 24 1M1024P 5/16" x 1 1/2" Hex Bolt</p>	 <p>No. 43 B-3861 Drawbar Pin</p>	 <p>No. 6 F-577 "E" Type Snap Ring</p>	 <p>No. 55 45M0909P 1/4" Flat Washer</p>	 <p>No. 36 F-787 Curve & Spring Washer</p>
 <p>No. 8 F-575 1/4" Thrust Washer</p>	 <p>No. 30 F-595 Lock Clip</p>	 <p>No. 29 F-591 Fan Driver</p>	 <p>No. 1 50M0416P 1/8" x 1" Cotter Pin</p>	 <p>No. 32 45M2121P 5/8" Flat Washer</p>	 <p>No. 20 B-4786 5/16" Nylon Insert Nut</p>	 <p>No. 46 B-1674P 5/16" Hex Lock Nut</p>
 <p>No. 12 20M0808P 1/4" x 1/2" Round Head Screw</p>	 <p>No. 19 20M0814P 1/4" x 7/8" Round Head Screw</p>	 <p>No. 54 F-395 1/4" x 3/4" Hex Head Screw</p>	 <p>No. 22 F-283 5/8" I.D. Axle Bearing</p>	 <p>No. 48 R-618 5/16" Heavy Washer</p>	 <p>No. 16 B-4785 1/4" Nylon Insert Nut</p>	 <p>No. 7 B-1673P 1/4" Hex Lock Nut</p>
 <p>No. 49 B-3805 Latch Spring</p>	 <p>No. 15 F-789 Vinyl Grip (small)</p>	 <p>No. 37 F-781 Gage Stop</p>	 <p>No. 35 10M1012P 5/16" x 3/4" Carriage Bolt</p>	 <p>No. 9 F-313 1/4" Gate "O" Ring</p>	 <p>No. 3 F-365 3/8" I.D. "O" Ring</p>	 <p>No. 5 F-574 Fan Shaft Bearing w/Groove</p>
 <p>No. 47 B-3721 Latch Spacer</p>	 <p>No. 38 F-782 Knob</p>	 <p>No. 2 F-436 Torsion Spring Agitator</p>	 <p>No. 44 10M1032P 5/16" x 2" Carriage Bolt</p>	 <p>No. 33 F-620 Hairpin Cotter</p>	 <p>No. 42 D-146P 1/8" Hairpin Cotter</p>	

BST-250 BH

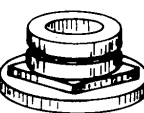
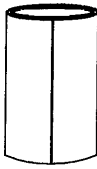
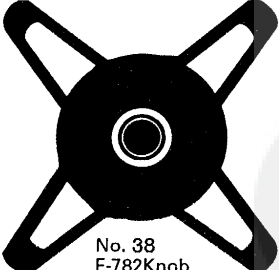
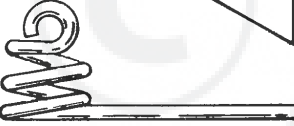
GEARBOX/AXLE ASSEMBLY

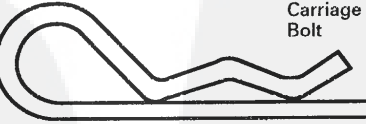
TO ORDER PARTS:
 Brinly-Hardy Company
 P.O. Box 18
 Jeffersonville, IN 47131-0018

(877) 728-8224

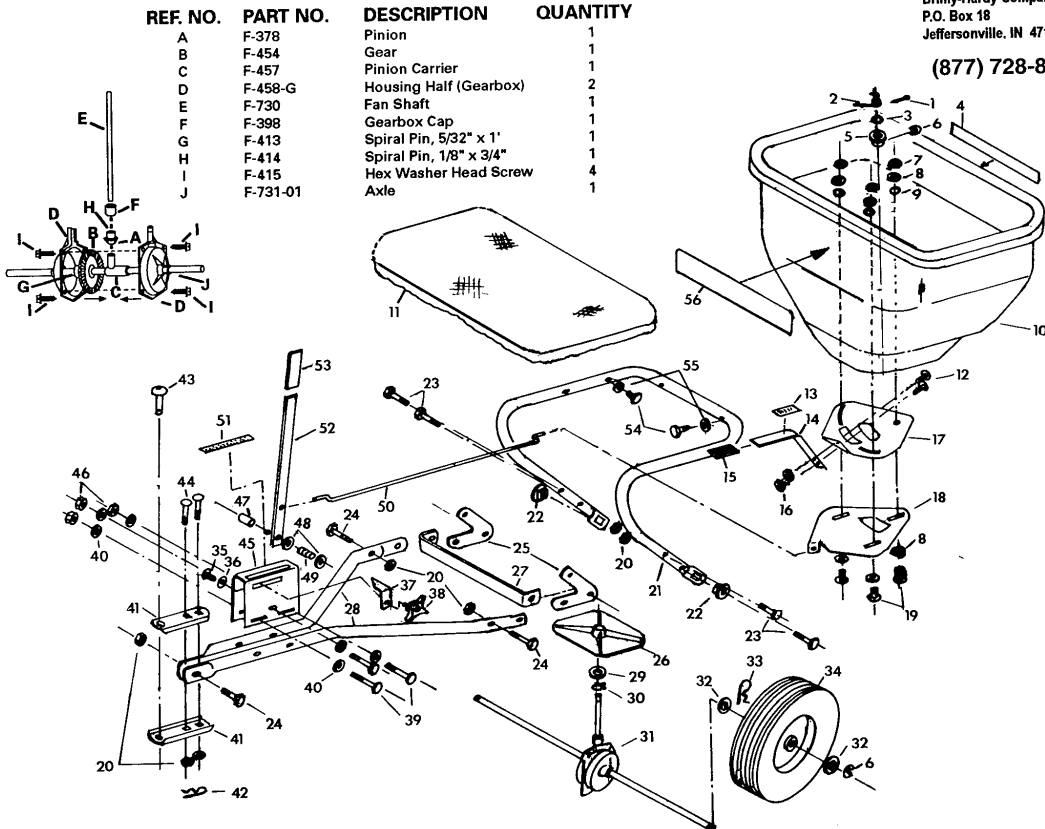

PARTS LIST

REF. NO.	PART NO.	DESCRIPTION	QUANTITY	REF. NO.	PART NO.	DESCRIPTION	QUANTITY
				29	F-591	Fan Driver	1
				30	F-595	Lock Clip	1
1	50M0416P	Cotter Pin - 1/8" x 1"	1	31	F-770	Gear Box Assembly	1
2	F-436	Agitator Spring	1	32	45M2121P	Flat Washer, 5/8"	6
3	F-365	Fan Shaft "O" Ring (large)	1	33	F-620	Hairpin Cotter (large)	2
4		Logo Decal	1	34	F-705	Wheel	2
5	F-574	Fan Bearing (small)	1	35	10M1012P	Carriage Bolt, 5/16" x 3/4"	1
6	F-577	Snap Ring	3	36	F-787	Spring Washer, 5/16"	1
7	B-1673P	Hex Lock (Domed) Nut	3	37	F-781	Stop Gage	1
8	F-575	Nylon Washer	6	38	F-782	Knob	1
9	F-313	Shutter "O" Ring (small)	3	39	1M1044P	Hex Bolt, 5/16" x 2 3/4"	3
10	F-718	Hopper	1	40	45M1111P	Flat Washer, 5/16"	6
11	F-745	Moisture Cover	1	41	R-892-10	Hitch Clevis	2
12	20M0808P	Round Head Screw, 1/4" x 1/2"	2	42	D-146P	Hairpin Cotter (small)	1
13	F-790	Decal (Directional Handle)	1	43	B-3861	Hitch Pin	1
14	F-784	Directional Handle (shutter)	1	44	10M1032P	Carriage Bolt, 5/16" x 2"	2
15	F-789	Vinyl Grip (small)	1	45	F-762-10	Gage Plate	1
16	B-4785	Nylon Insert Nut - 1/4"	2	46	B-1674P	Hex Lock (domed) Nut, 5/16"	1
17	F-767	Shutter Plate (directional)	1	47	B-3721	Latch Spacer	1
18	F-765	Flow Control Plate	1	48	R 618	Heavy Washer, 5/16"	2
19	20M0814P	Round Head Screw, 1/4" x 7/8"	3	49	B03805	Latch Spring	1
20	B-4786	Nylon Insert Nut, 5/16"	11	50	F-761	Link Rod	1
21	F-755-10	Hopper Support	1	51	F-740	Flow Control Decal	1
22	F-283	Bearing Axle (large)	2	52	F-738-10	Flow Control Handle	1
23	1M1032P	Hex Bolt, 5/16" x 2"	4	53	R-1882	Vinyl Grip (large)	1
24	1M1024P	Hex Bolt, 5/16" x 1 1/2"	3	54	F-395	Hex Tapping Screw, 1/4" x 3/4"	6
25	F-758-10	Gusset Plate	2	55	45M0909P	Flat Washer, 1/4"	6
26	F-573	Fan	1	56	F-744	Operation Decal	1
27	F-734-10	Cross Brace	1	57	L-1551-BH	Instructions	1
28	F-759-10	Tow Tube	2				

1551
 -1 BH