

PUSH IT LCP97PPW PULL IT



trailer dump car

TOW IT

Push/Pull version for added convenience!
 One Piece Heavy Duty Poly Hopper
 650 lb. Load Capacity
 Easy Dump Release and Steel Undercarriage
 16" Pneumatic Tires
 3/4" Solid Steel Axle

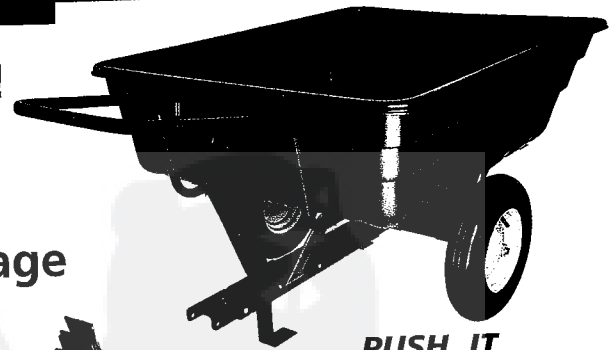

PUSH IT

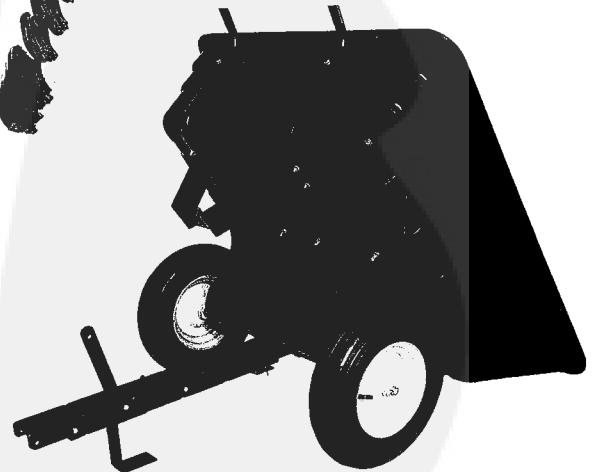

DUMP IT

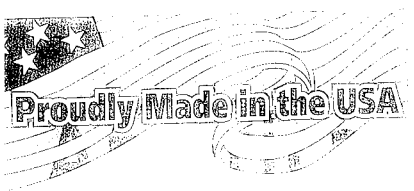
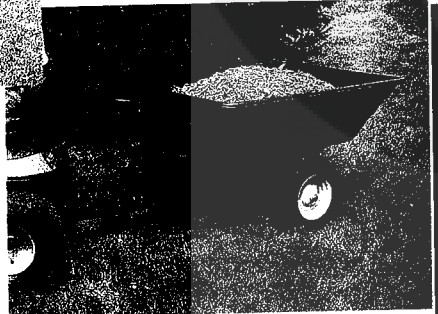

PRECISION PRODUCTS INC.

Please read and save these instructions for future reference.

Poly Hopper Push/Pull Trailer-Dump Cart

LCP97PPW

OPERATION FOR TOWING:

TO DUMP: Pull latch toward Tractor and Cart Body will tilt back to dump position.

TO RETURN TO TOWING POSITION: Push down on front edge of Cart Body until Latch engages and secures to Tow Bar.

**Tractor speed should be governed by weight of load. The heavier the load, the slower the speed for safe operation.

MAX. SPEED 4 MPH WITH LOAD

Note: 650 lb., 10 Cu. Ft. Maximum Capacity
Approximate weight (1) Cu. Ft.
Dirt - 150# Sand - 125# Gravel - 110#

WARNING OF DANGER OF IMPROPER USE OF THIS TRAILER CART:

THIS UNIT IS INTENDED FOR USE ONLY WITH RIDING LAWN MOWERS OR LAWN TRACTORS. DEFINITELY NOT FOR HIGHWAY USE, BEING PULLED AT HIGH SPEEDS, OR TRANSPORTING PASSENGERS OF ANY SORT. SUCH USE COULD RESULT IN INJURIES FOR WHICH WE CANNOT BE HELD RESPONSIBLE.

MAINTENANCE INSTRUCTIONS:

GREASE WHEELS: At regular intervals, at least every six months, more frequently if used regularly.

CHECK TIRE PRESSURE: At regular intervals. Proper inflation will prolong life of tires.

WARNING!: IN PUSH OR PULL MODE **DO NOT** RELEASE LOAD BY REACHING DOWN THROUGH HANDLE AREA OF CART. CART BODY AND HANDLE FUNCTION AS ONE UNIT AND SWING UP AND BACK AT SAME TIME AND MAY COME IN CONTACT WITH ARM OR HEAD

LIMITED WARRANTY

This unit is warranted against defects in materials and workmanship to the original purchaser, under normal use and service, for a period of ninety (90) days from date of sale. During the Warranty Period, we will repair or replace at our option free of charge to the original purchaser, any part of the unit that our examination shows to be defective in workmanship or materials.

This Warranty does not apply to damage in transit or damage caused by misuse, abuse, neglect, normal wear, or alterations by unauthorized persons.

ASSEMBLY

See last page of this manual for hardware guide.

STEP 1

Attach Undercarriage using 3/8" x 1-1/4" Truss Head Bolts and 1/2" Flat Washer from the **inside** of the Body. Secure with 3/8" Lock Washers and 3/8" Nuts. (Fig

STEP 2

Attach Gullwing Pedestal and Handle to the bottom and the front of the Body. Insert four 1/4" x 1-3/4" Truss Head Bolts and four 5/16" Washers through the **inside-bottom** of the Body. Secure with four 1/4" Lock Washers and 1/4" Hex Nuts. Insert two 1/4" x 2" Truss Head Bolts and two 5/16" Washers through the **inside-front** of the Body. Place Rubber Spacer on Bolts in between Body and Handle. Secure with two 1/4" Lock Washers and 1/4" Hex Nuts. Place Plastic Caps on all exposed bolts on Handle Assembly. (Figures 2 & 3)

FIG. 1

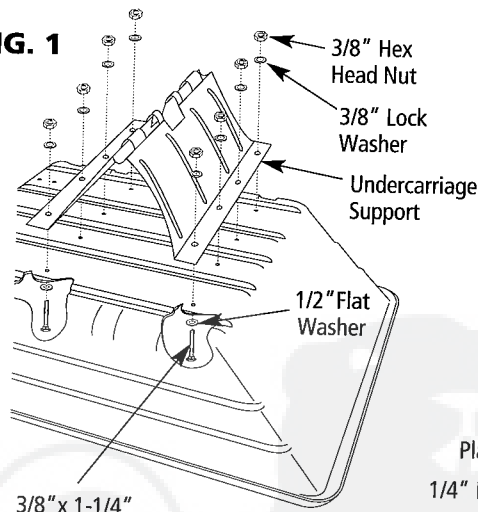

FIG. 2

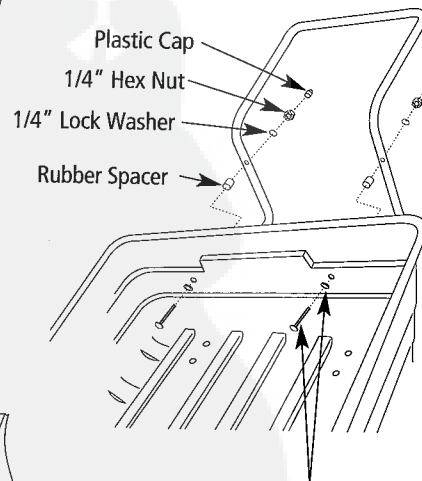
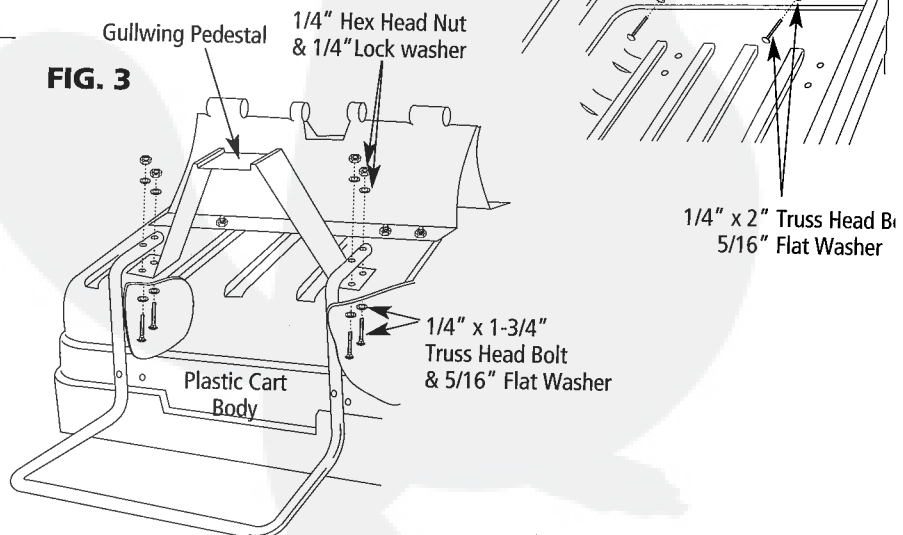
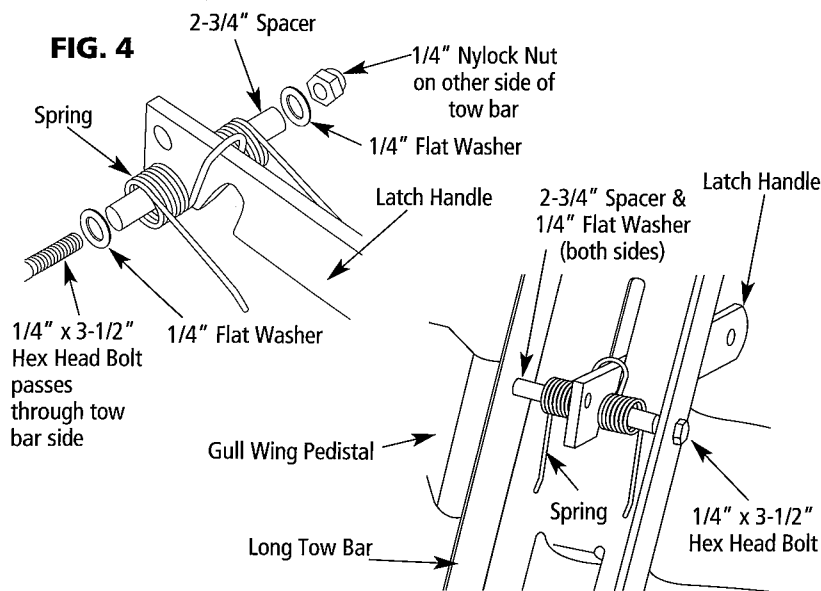

FIG. 3





STEP 3

Insert 2-3/4" x 1/4" Dia. Spacer through Spring and large hole at bottom of Latch. Be sure Spring is attached to Latch as shown. NOTE: Grab the latch handle from the other side of the Tow Bar and pull down to align the Spacer with the holes in the sides of the Tow Bar. Slide 1/4" x 3-1/2" Bolt through side of Long Tow Bar, the 1/4" Flat Washer (washers go on the inside of tow bar on either side of the long spacer), through the 2-3/4" Spacer and the other 1/4" Flat Washer and out the other side of Long Tow Bar. Secure with 1/4" Nylock Nut. (Fig. 4)

STEP 4

Attach Leg Stand to Short Tow Bar using 5/16" x 3/4" Bolts. Use 5/16" Lock Washers and 5/16" Nuts to secure. (Fig. 5)

STEP 5

Attach Clevis to top of Short Tow Bar with 5/16" x 3/4" Bolts. Use 5/16" Lock Washers and 5/16" Nuts to secure Bolts. Insert 1/2" x 1-3/4" Clevis Pin through hole in Clevis and Short Tow Bar. Secure with #14 Hitch Pin Clip. (Fig. 5)

STEP 6

Attach Long and Short Tow Bars together using 5/16" x 3-1/2" Clevis Pin through Towbar Assembly and secure with #203 Hitch Pin Clip. (Fig. 5)

STEP 8

Slide Axle through Undercarriage, Tow Bar assembly. (Fig. 6)

STEP 9

Center Axle and place Washer over Axle, followed by Wheel and another Washer on the outside of the Wheel. Secure with Cotter Pin. Repeat for other side. (Fig. 6)

STEP 10

Tighten all Nuts and Bolts at this time.

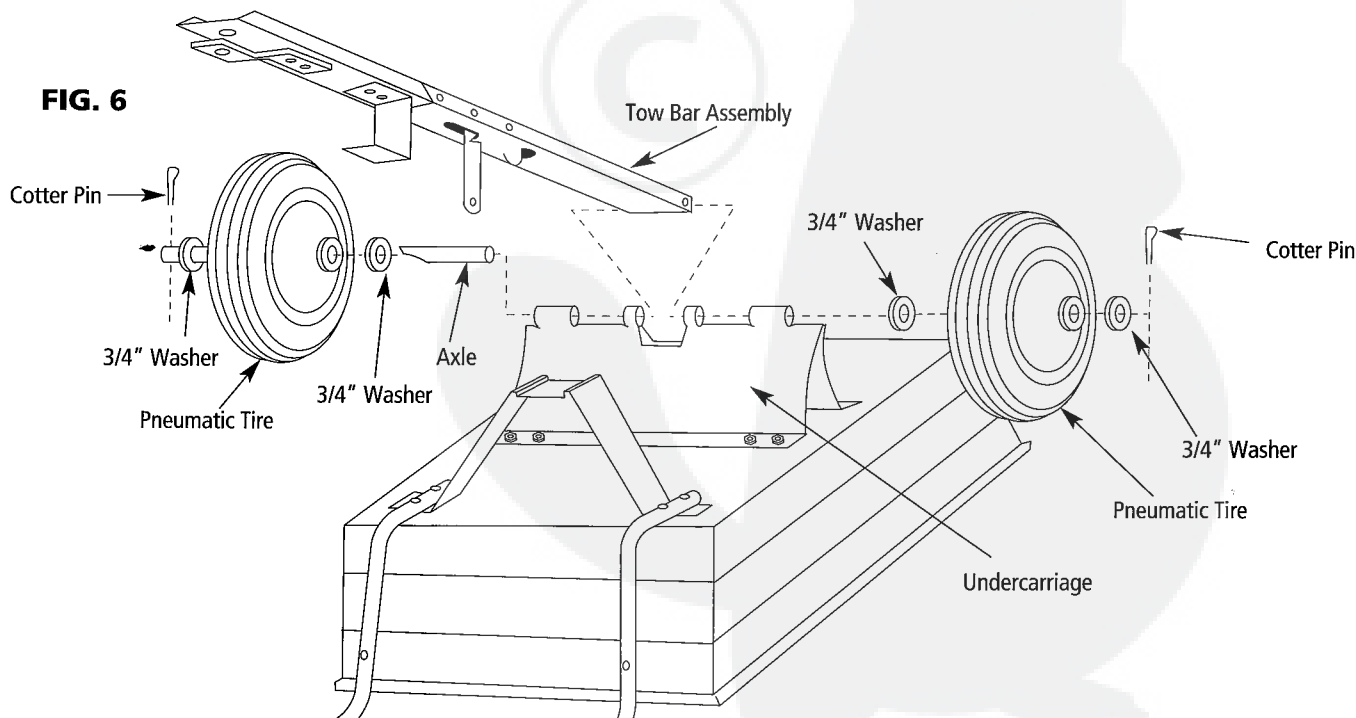
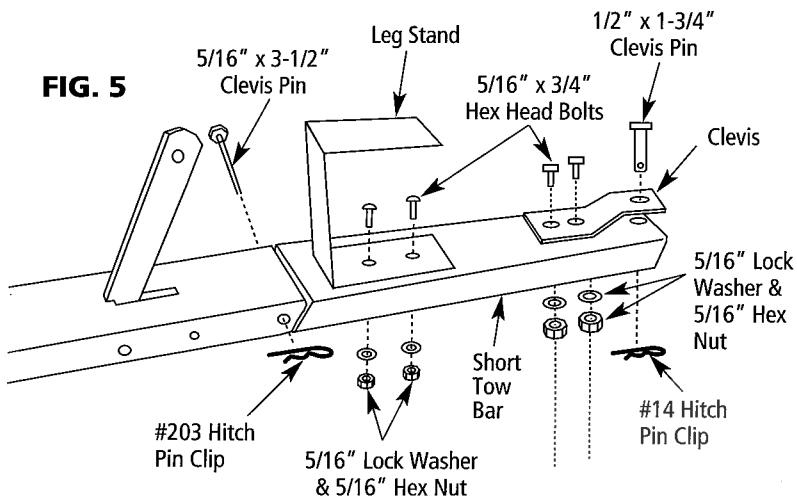

Push/Pull Trailer-Dump Cart

LCP97PPW

PLEASE DO NOT RETURN THIS MERCHANDISE TO THE STORE. CONTACT CUSTOMER SERVICE AS DETERMINED BY THE MODEL NUMBER OF YOUR UNIT.

For Replacement Parts

Please provide the following information:

- Model Number
 - Part description and number as shown in parts list
- Address parts correspondence to:

MODEL LCP97PPW

Precision Products, Inc.

316 Limit St.

Lincoln IL 62656

Phone: 800-225-5891 Ext. 204

(217) 735-1590

FAX: (217) 735-2435

PARTS LIST FOR LCP97PPW

Ref. No	Part No.	Description	Qty.
1	4614PP	Hopper	1
2	4630B	Gull Wing Pedestal	1
3	4556B	Undercarriage (Black)	1
4	4615P	Handle	1
5	1267	Wheel	2
6	1252	Axle	1
7	4650P	Long Tow Bar	1
8	4648P	Short Tow Bar	1
9	4617P	Leg	1
10	1265P	Latch	1
11	1042	#14 Hitch Pin Clip	1
12	1248	5/16" x 3/4" Hex Head Bolt	4
13	1262	1/8" x 1-1/4" Cotter Pin	2
14	1264	3/4" Flat Washer	4
15	1599	3/8" x 1-1/4" Truss Head Bolt	8
16	1273	3/8" Hex Head Nut	8
17	1274	3/8" Lock Washer	8
18	1275	5/16" Hex Head Nut	4
19	1276	5/16" Lock Washer	4
20	4638	1/4" x 1-3/4" Truss Head Bolt	4
21	4497	Spring	1
22	1558	1/4" Nylock Nut	2
23	1817	1/4" Flat Washer	2
24	1840	1/2" x 1-3/4" Clevis Pin	1
25	4466	1/4" x 3-1/2" Hex Head Bolt	2
26	4468	1/4" x 2-3/4" Spacer	1
27	1506	1/2" Flat Washer	8
28	2452	Plastic Nut Cover	6
29	4620	Rubber Spacer	2
30	4619	5/16" x 3-1/2" Clevis Pin	1
31	1270	1/4" Hex Head Nut	6
32	1044	5/16" Flat Washer	6
33	2455	#203 Hitch Pin	1
34	1807	1/4" Lock Washer	6
35	4639	1/4" x 2" Truss Head Bolt	2
36	1243P	Clevis	1

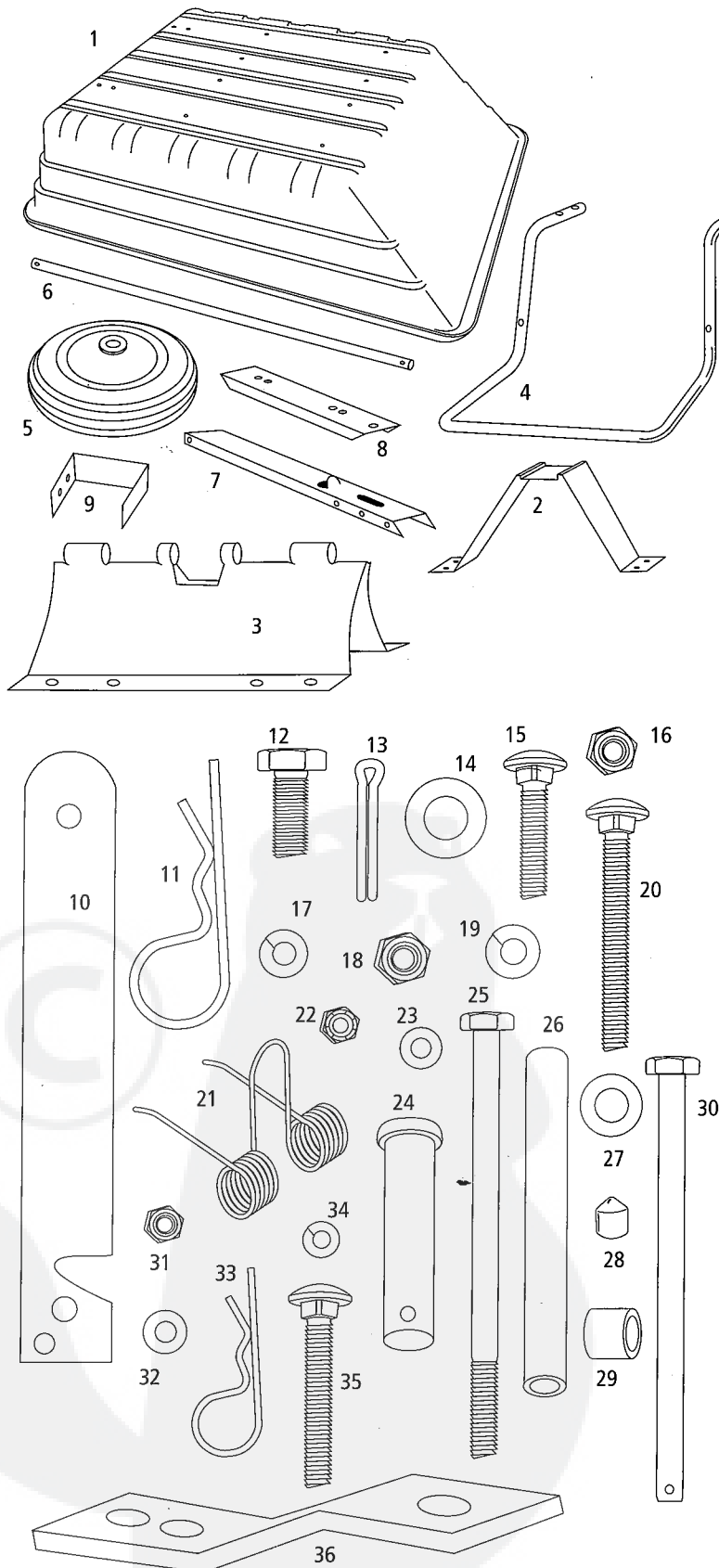

TIP: Many of these hardware parts can be purchased at your local hardware store.

MADE IN THE U.S.A.