

			60A	60S	70A	70S
1	80-1417-221-00	Handle	1	1	1	1
2	80-1516-108-00	Knob Bolt	1	1	1	1
3	80-1516-251-00	Washer	1	1	1	1
4	80-1515-966-00	Clutch SP	2	2	2	2
5	83-1417-932-10	Driving Clutch Wire	1	1	1	1
6	83-1560-414-00	Handle Grip 27	2	2	2	2
7	89-1111-060402	Hexagonal Bolt M6*40	2	2	2	2
8	89-1711-060002	Washer 6	4	4	4	4
9	89-1551-060002	U-type Nut M6	2	2	2	2
10	80-1417-241-10	Clutch Lever	1	1	1	1
11	80-1417-453-10	Knife Clutch Lever	1	1	1	1
12	83-1417-941-10	Knife Clutch Wire	1	1	1	1
13	89-2120-200152	Split Pin 2*15	1	1	1	1
14	80-1417-223-00	Control Panel CMP	1	1	1	1
15	80-1417-263-00	Change Lever	1	1	1	1
16	80-1310-268-00	Non Flap Spring	1	1	1	1
17	80-1417-266-00	Wire Guide B	1	1	1	1
18	89-2131-120002	Snap Pin 12	1	1	1	1
19	80-1210-267-00	Wire Guide Axle	1	1	1	1
20	89-1541-080002	Hexagonal Nut (SW) M8	1	1	1	1
21	83-1417-435-00	Lever Grip (Red)	1	1	1	1
22	83-1417-936-00	Change Wire	2	2	2	2
23	80-1484-273-10	Differential Lock Lever	1	1	1	1
24	80-1020-261-00	Throttle Lever (FC180V)	1	1		
24	80-1020-265-00	Throttle Lever (GXV160)	1	1		
24	80-1437-261-00	Throttle Lever (GXV270)	1	1	1	1
25	80-1020-270-00	Inner Collar	1	1	1	1
26	89-1139-080302	Hexagonal Bolt (PWSW) M8*30	1	1	1	1
27	80-1020-264-00	Control Washer	1	1	1	
28	80-1020-263-00	Control Axle Spring	1	1	1	1
29	89-1711-120003	Flat Washer 12	1	1	1	1
30	80-1020-262-00	Control Lever Axle	1	1	1	1
31	89-1113-080162	Hexagonal Bolt (PWSW) M8*16	4	4	4	4
32	83-1417-951-00	Throttle Wire (FC180V)	1	1		
32	83-1417-952-00	Throttle Wire (GXV160)	1	1		

32	83-1437-952-10	Throttle Wire (GXV270)	1	1	1	1
33	83-1417-937-20	Differential Lock Wire	1	1	1	1
34	80-1417-155-00	Spring	1	1	1	1
35	80-1484-262-00	Arm Grip(red) GXV270	1	1	1	1
36	80-1515-262-00	Arm Grip(black)	1	1	1	1
	80-1417-904-00	Label	1			
	80-1417-905-00	Label		1		
	80-1437-904-00	Label			1	
	80-1437-905-00	Label				1
	80-1417-914-00	Label	1	1	1	1
	80-1417-915-00	Label	1	1	1	1
	80-1417-911-00	Label	1	1	1	1



SH60 / SH70

FIG. 2 FRAME

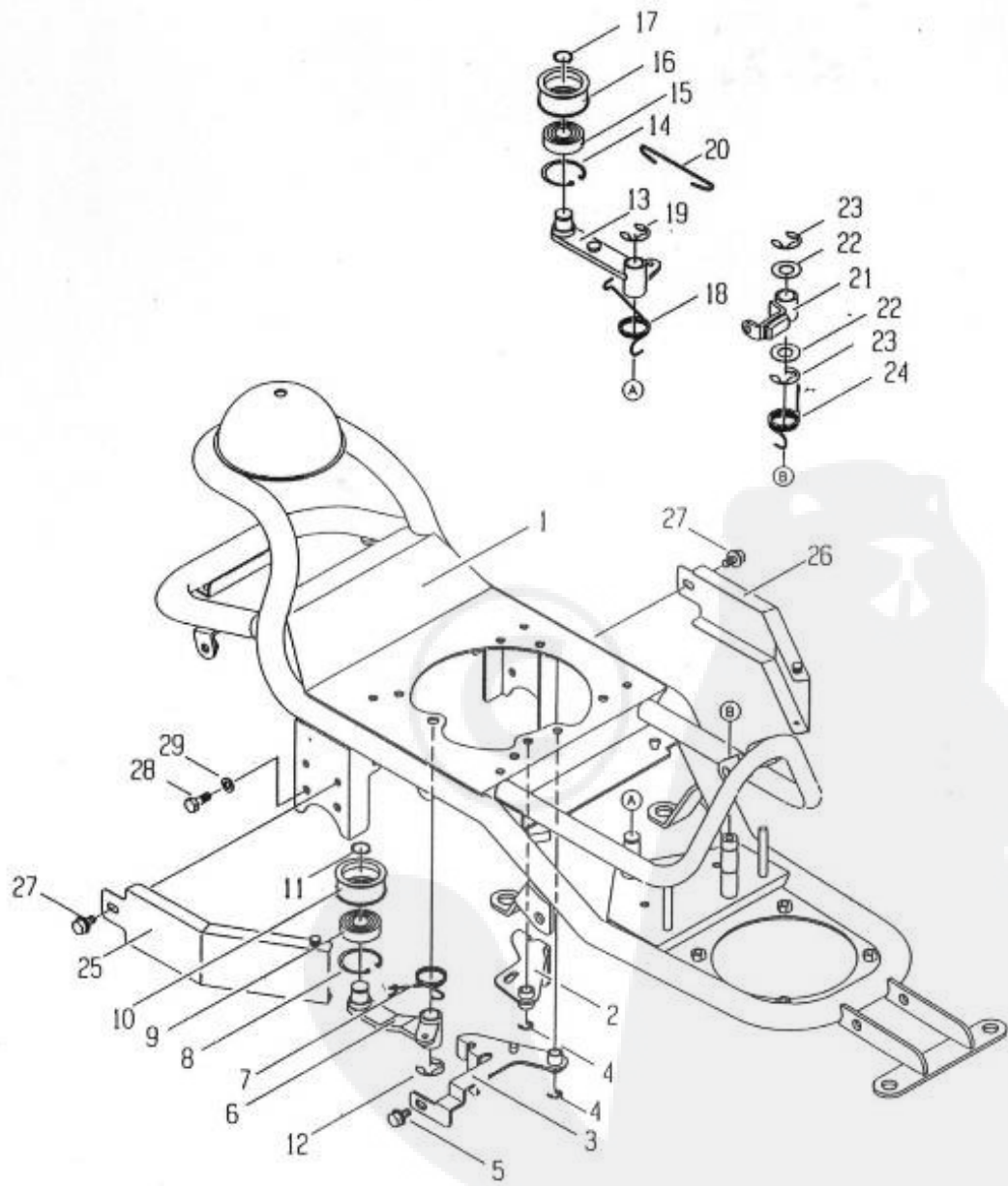

Ref.	Parts No.	Parts Name	Quantity	Remarks
------	-----------	------------	----------	---------

			SH 60A	SH 60S	SH 70A	SH 70S
1	80-1417-301-10	Frame CMP	1	1	1	1
2	80-1417-518-00	Engine Belt Stopper A	1	1	1	1
3	80-1417-519-00	Engine Belt Stopper B	1	1	1	1
4	89-2521-000080	E-Type Ring 8	2	2	2	2
5	89-1133-080162	Hexagonal Bolt (PWSW) M8*16	1	1	1	1
6	80-1417-542-00	Tension Arm	1	1	1	1
7	80-1417-552-00	Return Spring	1	1	1	1
8	89-2512-000400	Snap Ring 40	1	1	1	1
9	89-3115-062034	Bearing 6203 2RS	1	1	1	1
10	83-1032-765-00	Tension Pulley	1	1	1	1
11	89-2511-000170	Snap Ring 17	1	1	1	1
12	89-2521-000150	E-Type Ring 15	1	1	1	1
13	80-1417-546-10	Knife Tension Arm	1	1	1	1
14	89-2512-000400	Snap Ring 40	1	1	1	1
15	89-3115-062034	Bearing 6203 2RS	1	1	1	1
16	83-1032-765-00	Tension Pulley	1	1	1	1
17	89-2511-000170	Snap Ring 17	1	1	1	1
18	80-1417-568-10	Return Spring	1	1	1	1
19	89-2521-000150	E-Type Ring 15	1	1	1	1
20	80-1417-374-00	Brake Rod	1	1	1	1
21	80-1417-371-00	Knife Brake	1	1	1	1
22	83-1020-363-00	Thrust Washer 16*24*1	2	2	2	2
23	89-2521-000150	E-Type Ring 15	2	2	2	2
24	80-1417-373-00	Return Spring	1	1	1	1
25	80-1417-503-10	Engine Pulley Cover (Right)	1	1	1	1
26	80-1417-505-10	Engine Pulley Cover (Left)	1	1	1	1
27	89-1133-080162	Hexagonal Bolt (PWSW) M8*16	2	2	2	2
28	89-1113-080162	Hexagonal Bolt (8T) M8*16	4	4	4	4
29	89-1750-080002	Spring Washer 8	4	4	4	4

SH60 / SH70
 FIG. 3 ENGINE PARTS

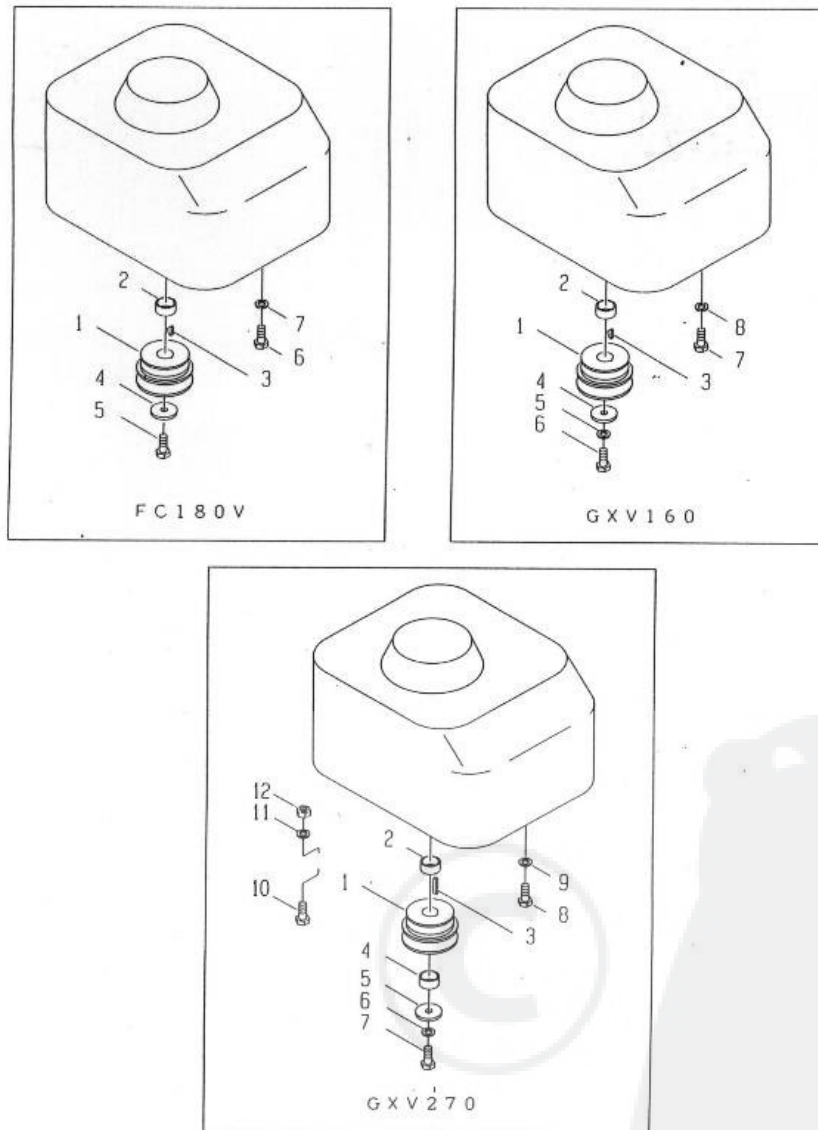

FIG. 3 Engine Parts (KAWASAKI FC180V) [Fig open](#)

Ref.	Parts No.	Parts Name	Quantity				Remarks
			SH 60A	SH 60S	SH 70A	SH 70S	
1	80-1417-514-10	Engine Pulley	1	1			
2	80-1417-516-10	Pulley Collar	1	1			
3	89-2160-040160	Key 4*16	1	1			
4	83-1610-321-00	Washer 10*36*4.5	1	1			
5	83-1020-118-00	Hexagonal Bolt 3/8-24*32UNF	1	1			

6 89-1113-100252 Hexagonal Bolt (8T) M10*25

4 4

7 89-1750-100002 Spring Washer 10

4 4

SH60 / SH70
FIG. 3 ENGINE PARTS

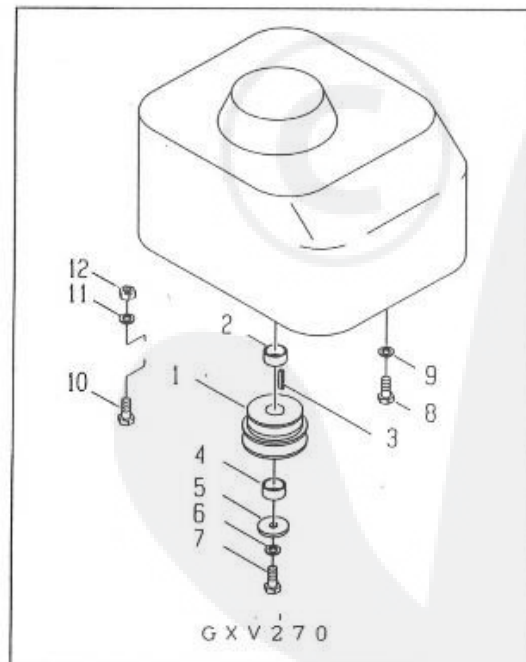
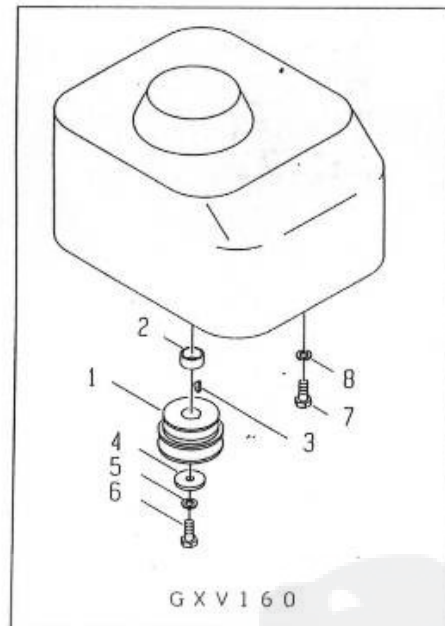
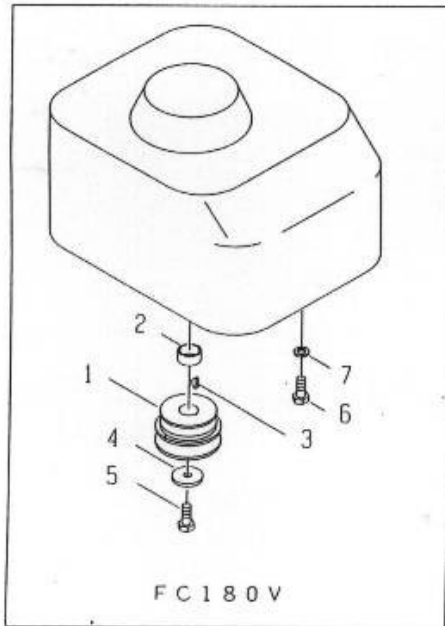

Ref.	Parts No.	Parts Name	Quantity	Remarks
------	-----------	------------	----------	---------

			SH 60A	SH 60S	SH 70A	SH 70S	
1	80-1417-515-10	Engine Pulley	1	1			
2	80-1417-517-10	Pulley Collar	1	1			
3	89-2160-040160	Key 4*16	1	1			
4	83-1610-321-00	Washer 10*36*4.5	1	1			
5	89-1750-100002	Spring Washer 10	1	1			
6	89-1113-100352	Hexagonal Bolt (8T) M10*35	1	1			
7	83-1482-116-00	Hexagonal Bolt UNF5/16- 24*25	4	4			
8	89-1750-080002	Spring Washer 8	4	4			



SH60 / SH70
 FIG. 3 ENGINE PARTS

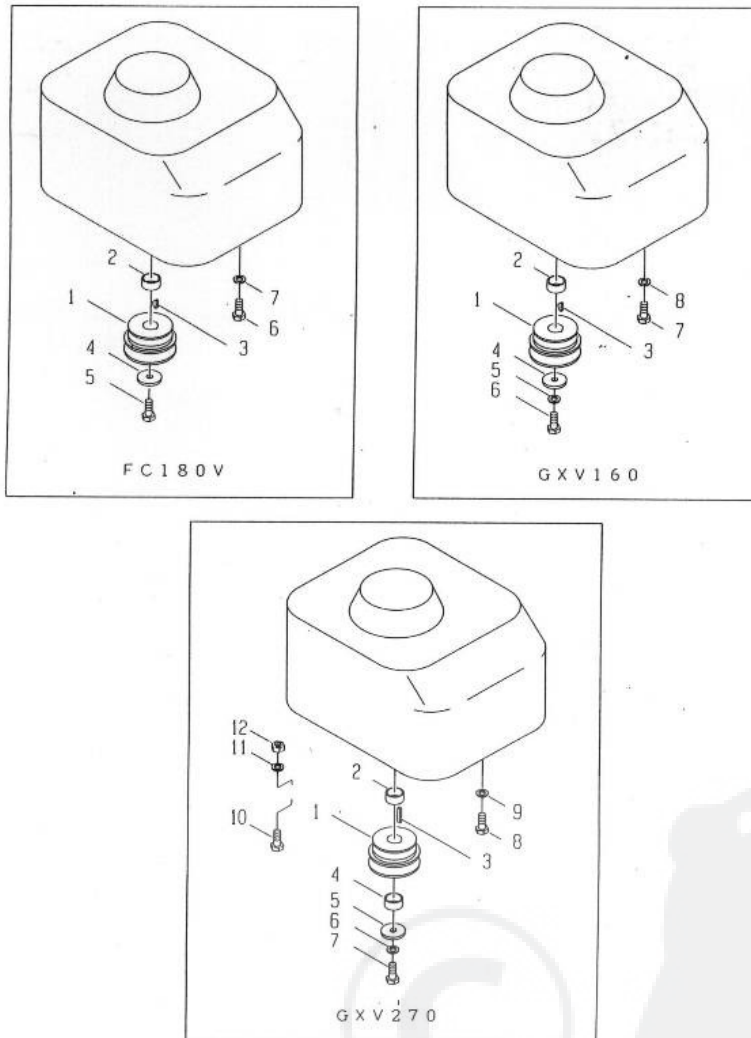

Ref.	Parts No.	Parts Name	Quantity				Remarks
			SH 60A	SH 60S	SH 70A	SH 70S	
1	80-1437-514-10	Engine Pulley	1	1	1	1	
2	80-1437-516-10	Pulley Collar	1	1	1	1	
3	83-1437-205-00	Key 1/4"*40	1	1	1	1	
4	80-1330-515-00	Pulley Collar L13	1	1	1	1	
5	83-1482-319-00	Washer 11*36*4.5	1	1	1	1	
6	89-1750-120002	Spring Washer 12	1	1	1	1	
7	83-1437-115-00	Hexagonal Bolt (8T) UNF7/16*35	1	1	1	1	
8	83-1482-116-00	Hexagonal Bolt UNF5/16- 24*25	2	2	2	2	

9	89-1750-080002	Spring Washer 8	2	2	2	2
10	89-1113-080402	Hexagonal Bolt (8T) M8*40	2	2	2	2
11	89-1750-080002	Spring Washer 8	2	2	2	2
12	89-1511-080042	Hexagonal Nut M8	2	2	2	2

SH60 / SH70

FIG. 4 TRANSMISSION OUTSIDE & REAR WHEEL

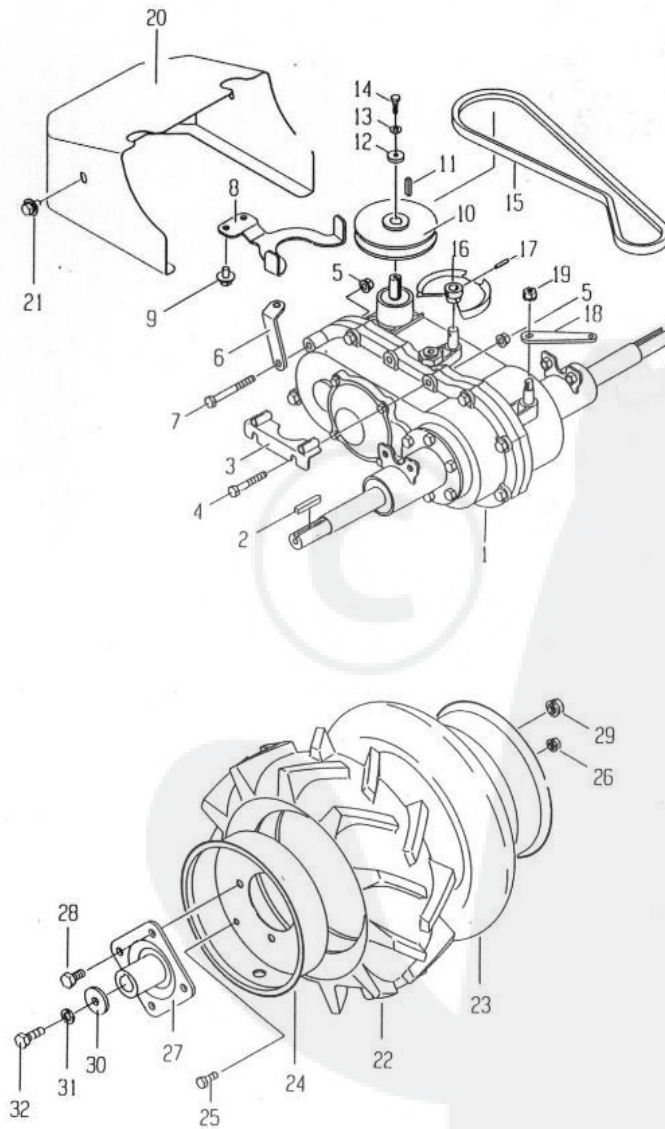

Ref.	Parts No.	Parts Name	Quantity				Remarks
			SH 60A	SH 60S	SH 70A	SH 70S	
1	80-1417-100-10	Transmission Case ASSY	1	1	1	1	
2	89-2151-070400	Key 7*40	2	2	2	2	
3	80-1417-195-00	Receiver for Change Wire	1	1	1	1	
4	89-1251-080502	Bolt M8*50	8	8	8	8	
5	89-1555-080002	U-Type Nut M8	12	12	12	12	
6	80-1417-198-00	Transmission Arm	1	1	1	1	
7	89-1251-080702	Bolt M8*70	1	1	1	1	
8	80-1417-527-10	Driving Belt Stopper	1	1	1	1	
9	89-1133-080162	Hexagonal Bolt (PWSW) M8*16	3	3	3	3	
10	80-1417-521-10	Transmission Pulley	1	1	1	1	
11	89-2151-050250	Key 5*25	1	1	1	1	
12	83-1482-311-00	Washer 6*22*3.2	1	1	1	1	
13	89-1750-060002	Spring Washer 6	1	1	1	1	
14	89-1113-060202	Hexagonal Bolt (8T) 6*20	1	1	1	1	
15	89-6122-003501	V Belt SA-35	1	1	1	1	
16	80-1417-191-00	Wire Guard A	1	1	1	1	
17	89-2111-050020	Spring Pin 5x20	1	1	1	1	
18	80-1417-153-00	Differential Lock Arm	1	1	1	1	
19	89-1541-080002	Hexagonal Nut (SW) M8	1	1	1	1	
20	80-1417-504-00	Transmission Pulley Cover	1	1	1	1	
21	89-1133-080162	Hexagonal Bolt (PWSW) M8*16	2	2	2	2	
22	80-1711-401-00	Tire (400-7)	2	2	2	2	
23	80-1711-404-00	Tube (400-7)	2	2	2	2	
24	80-1711-407-00	Wheel Assy (400-7)	2	2	2	2	
25	89-1111-080202	Hexagonal Bolt M8*20	8	8	8	8	
26	89-1541-080002	Hexagonal Nut (SW) M8	8	8	8	8	
27	80-1565-413-00	Wheel Boss	2	2	2	2	
28	89-1111-100202	Hexagonal Bolt M10*20	8	8	8	8	
29	89-1541-100002	Hexagonal Nut (SW) M10	8	8	8	8	
30	83-1610-321-00	Washer 10*36*4.5	2	2	2	2	
31	89-1750-100002	Spring Washer 10	2	2	2	2	
32	89-1113-100252	Hexagonal Bolt (8T) M10*25	2	2	2	2	
	89-2150-070500	Key 7*50	2	2	2	2	

SH60 / SH70
FIG. 5 TRANSMISSION

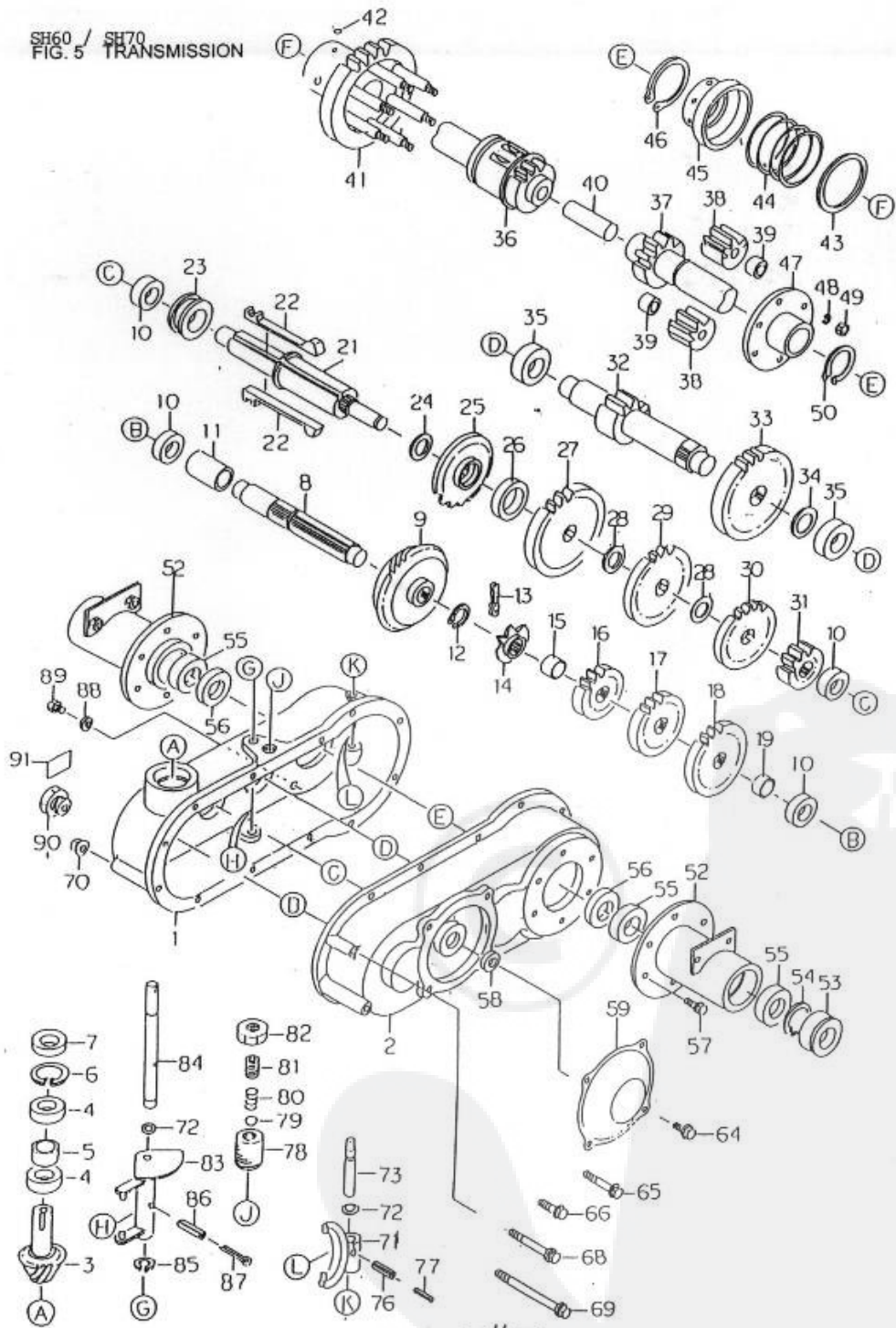

XH97K00266~
XJ97L00056~

SH60 / SH70
FIG. 5 TRANSMISSION

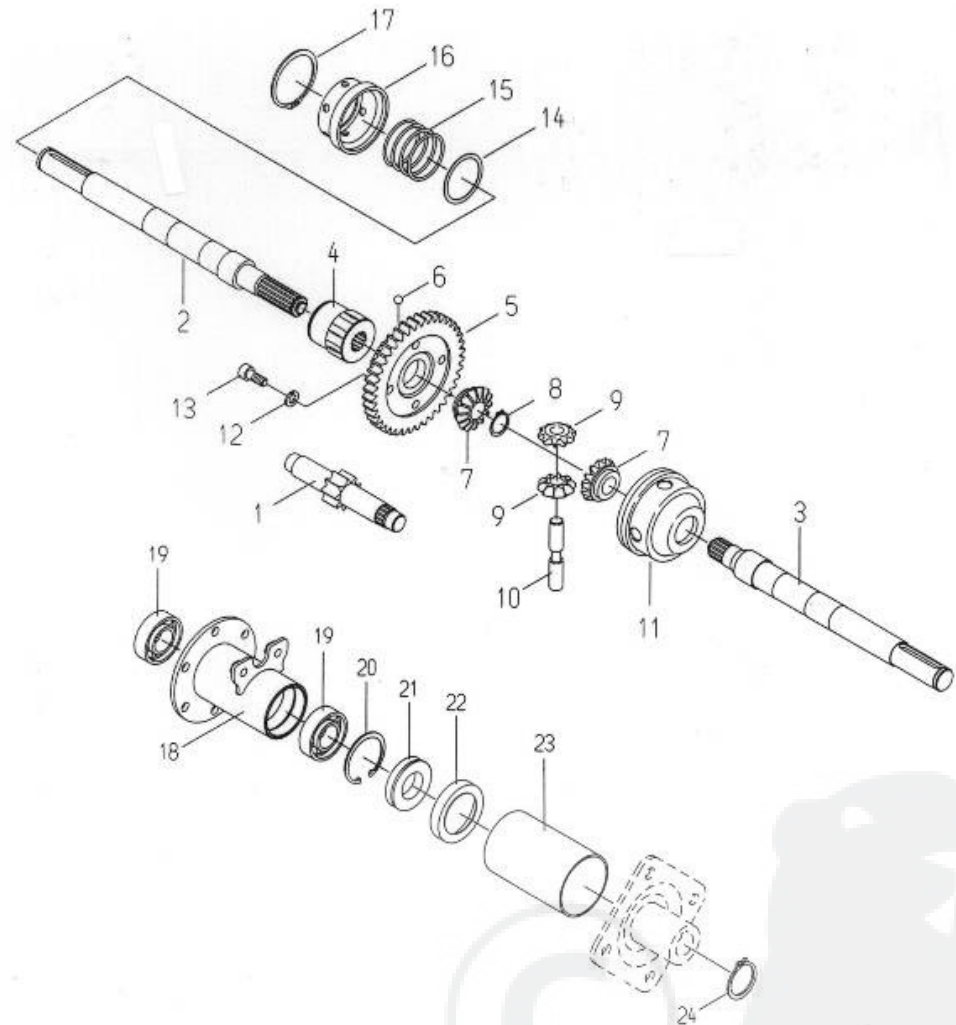

(XH97K00266- XJ97L00056-)

Ref.	Parts No.	Parts Name	Quantity				Remarks
			SH 60A	SH 60S	SH 70A	SH 70S	
1	80-1482-101-00	Transmission Case (Left)	1	1	1	1	
2	80-1482-103-00	Transmission Case (Right)	1	1	1	1	
3	80-1481-118-00	A Axle 15T	1	1	1	1	
4	89-3115-062024	Bearing 6202 2RS	2	2	2	2	
5	80-1482-119-00	A Axle Collar 9	1	1	1	1	
6	89-2512-000350	Snap Ring 35	1	1	1	1	
7	89-5121-153507	Oil Seal AD.15.35.7	1	1	1	1	
8	80-1482-122-00	B Axle	1	1	1	1	
9	80-1482-127-00	Bevel Gear 45T	1	1	1	1	

10	89-3111-062024	Bearing 6202	4	4	4	4
11	80-1482-131-00	Collar 18*22*34	1	1	1	1
12	89-2511-000170	Snap Ring 17	1	1	1	1
13	89-6513-420024	Chain 420-24L	1	1	1	1
14	80-1482-128-00	B Axle Sprocket 8T	1	1	1	1
15	80-1417-129-00	Collar 18*22*16.5	1	1	1	1
16	80-1417-123-00	B Axle Gear 20T	1	1	1	1
17	80-1417-124-00	B Axle Gear 26T	1	1	1	1
18	80-1481-125-00	B Axle Gear 33T	1	1	1	1
19	80-1482-130-00	Collar 18*22*11	1	1	1	1
21	80-1482-132-00	C Axle	1	1	1	1
22	80-1482-113-00	Shift Key	2	2	2	2
23	80-1481-111-00	Shift Key Holder	1	1	1	1
24	80-1481-139-00	C Axle Washer 29*40*1.0	1	1	1	1
25	80-1482-138-00	Sprocket 18T	1	1	1	1
26	80-1417-136-00	C Axle Collar	1	1	1	1
27	80-1417-137-00	C Axle Gear 45T	1	1	1	1
28	80-1482-139-00	C Axle Thrust Washer	2	2	2	2
29	80-1417-138-00	C Axle Gear 39T	1	1	1	1
30	80-1417-135-00	C Axle Gear 33T	1	1	1	1
31	80-1482-133-00	C Axle Gear 12T	1	1	1	1
32	80-1482-142-00	D Axle	1	1	1	1
33	80-1482-144-00	D Axle Gear 36T	1	1	1	1
34	83-1830-368-00	Thrust Washer 18*26*1.0	1	1	1	1
35	89-3111-062034	Bearing 6203	2	2	2	2
36	80-1417-146-00	Axle (Left) CMP	1	1	1	1
37	80-1417-147-00	Axle (Right) CMP	1	1	1	1
38	80-1481-152-00	Differential Gear 11T	4	4	4	4
39	80-1481-155-00	Differential Gear Axle Collar	4	4	4	4
40	80-1415-150-00	Axle Pin	1	1	1	1
41	80-1481-148-00	Axle Gear CMP	1	1	1	1
42	89-3410-075000	Steel Ball 7.5	3	3	3	3
43	83-1830-382-00	Thrust Washer 40*48*1.0	1	1	1	1
44	80-1417-162-00	Differential Lock Spring	1	1	1	1
45	80-1425-143-00	Differential Lock Cone	1	1	1	1
46	89-2511-000400	Snap Ring 40	1	1	1	1
47	80-1481-151-00	Differential Lock Plate	1	1	1	1
48	89-1750-100002	Spring Washer	6	6	6	6

49	89-1513-100042	Hexagonal Nut M10	6	6	6	6
50	89-2511-000280	Snap Ring 28	1	1	1	1
52	80-1417-156-10	Axle BB Case CMP	2	2	2	2
53	83-1415-663-00	Oil Seal AP30.47.7	2	2	2	2
54	89-2512-000470	Snap Ring 47	2	2	2	2
55	89-3115-060054	Bearing 6005 2RS	4	4	4	4
56	89-5121-284708	Oil Seal UE 28.47.8	2	2	2	2
57	83-1482-143-00	Hexagonal Tap Bolt M10*25	12	12	12	12
58	89-5121-153007	Oil Seal UE 15.30.7	1	1	1	1
59	80-1417-285-00	Brake Axle Cover	1	1	1	1
64	83-1020-148-00	Hexagonal Tap Bolt M6*14	4	4	4	4
65	89-1251-080502	Washer Bolt M8*50	8	8	8	8
66	89-1251-080402	Washer Bolt M8*40	1	1	1	1
68	89-1251-080702	Washer Bolt M8*70	1	1	1	1
69	89-1251-081402	Washer Bolt M8*140	2	2	2	2
70	89-1555-080002	U Type Nut M8	12	12	12	12
71	80-1830-113-00	Differential Lock Fork	1	1	1	1
72	89-5221-009000	O Type Ring P9	2	2	2	2
73	80-1481-116-00	Differential Lock Fork Axle	1	1	1	1
76	89-2111-050020	Spring Pin 5*20	1	1	1	1
77	89-2111-030020	Spring Pin 3*20	1	1	1	1
78	80-1482-162-00	Screw for Adjusting Notch	1	1	1	1
79	89-3410-080000	Steel Ball 8	1	1	1	1
80	80-1481-160-00	Spring 1.0	1	1	1	1
81	89-1172-100161	Screw M10*16	1	1	1	1
82	89-1514-160042	Hexagonal Nut (3 sort) M16	1	1	1	1
83	80-1482-108-00	Shift Fork	1	1	1	1
84	80-1417-110-00	Shift Fork Axle	1	1	1	1
85	89-2511-000120	Snap Ring 12	1	1	1	1
86	89-2111-050020	Spring Pin 5*20	1	1	1	1
87	89-2120-300252	Split Pin 3*25	1	1	1	1
88	89-5230-100000	Seal Washer 10	1	1	1	1
89	89-1111-100122	Hexagonal Bolt M10*12	1	1	1	1
90	83-1032-689-00	Oil Gauge M28	1	1	1	1
91	83-1712-923-00	Oil Mark 1.6	1	1	1	1

SH60 / SH70
 FIG. 6 KNIFE COVER

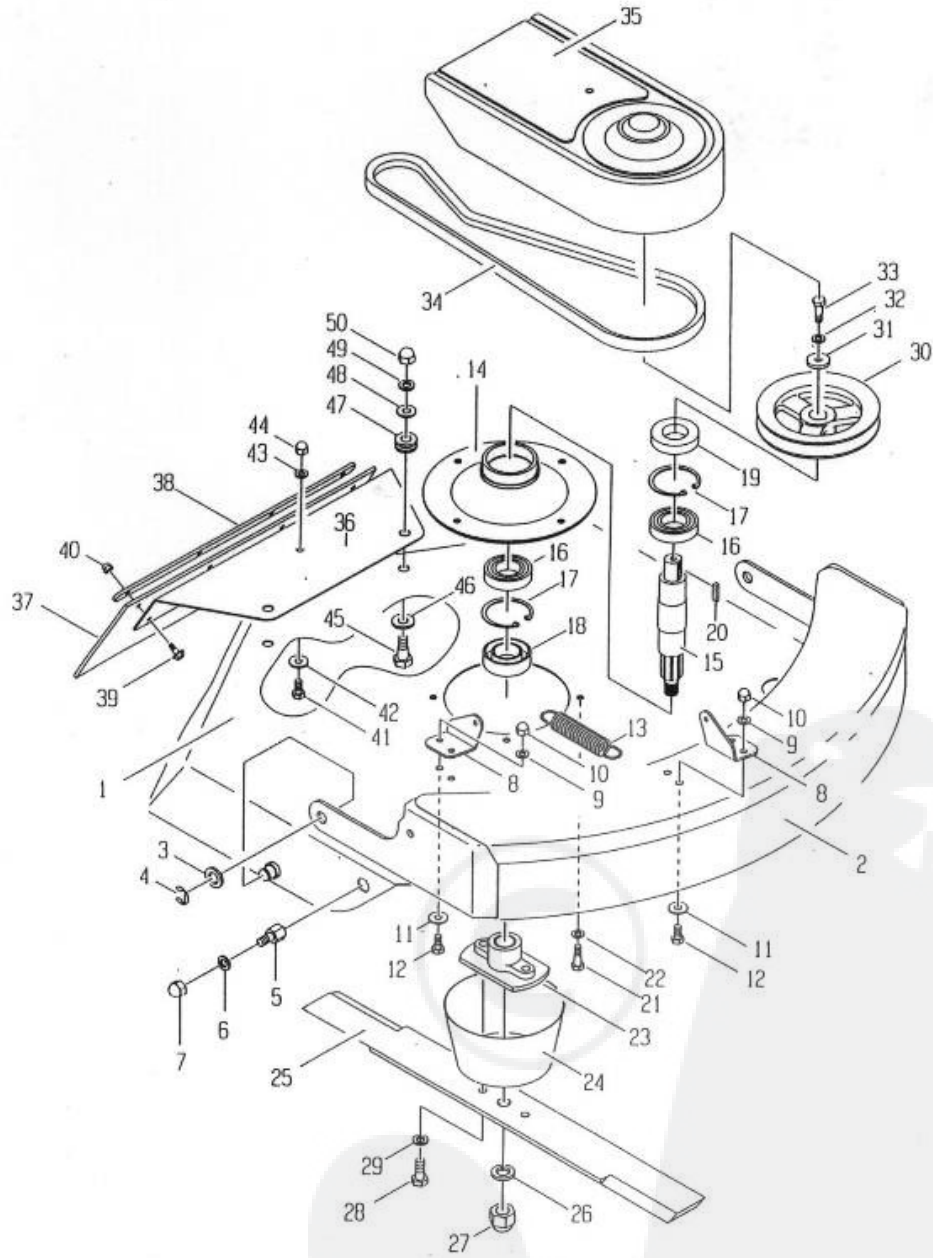

Ref.	Parts No.	Parts Name	Quantity				Remarks
			SH 60A	SH 60S	SH 70A	SH 70S	
1	180-1417-731-10	Knife Cover CMP	1	1			

1	80-1437-731-10	Knife Cover CMP			1	1
2	80-1417-733-00	Front Guard CMP	1	1		
2	80-1437-733-00	Front Guard CMP			1	1
3	83-1630-342-00	Washer 16*26*2.3	2	2	2	2
4	89-2521-000150	E Type Ring 12	2	2	2	2
5	80-1417-736-00	Bolt for Fixing Front Guard	2	2	2	2
6	89-1750-100002	Spring Washer 10	2	2	2	2
7	89-1571-100042	Nut M10	2	2	2	2
8	80-1020-705-30	Lock Arm Bracket A	2	2	2	2
9	89-1750-080002	Spring Washer 8	4	4	4	4
10	89-1571-080042	Nut M8	4	4	4	4
11	89-1714-080002	Flat Washer 8	4	4	4	4
12	89-1113-080162	Hexagonal Bolt (8T) M8*16	4	4	4	4
13	80-1417-735-00	Spring	1	1	1	1
14	80-1417-601-00	Knife BB Case	1	1	1	1
15	80-1417-641-00	Knife Axle	1	1	1	1
16	89-3115-060064	Bearing 6006 2RS	2	2	2	2
17	89-2512-000550	Snap Ring 55	2	2	2	2
18	83-1415-662-00	Oil Seal AP 35.55.8	1	1	1	1
19	89-5121-305512	Oil Seal UE 30.55.12	1	1	1	1
20	89-2151-050250	Key 5x25	1	1	1	1
21	89-1113-080252	Hexagonal Bolt (8T) M8*25	4	4	4	4
22	89-1750-080002	Spring Washer 8	4	4	4	4
23	80-1415-733-00	Knife Bracket	1	1	1	1
24	80-1415-836-00	Knife Neck Guard	1	1	1	1
25	80-1415-821-00	Bar Knife	1	1		
25	80-1445-821-00	Bar Knife			1	1
26	89-1750-160002	Spring Washer 16	1	1	1	1
27	89-1572-160042	Nut M16	1	1	1	1
28	89-1113-100252	Hexagonal Bolt (8T) M10*25	2	2	2	2
29	89-1750-100002	Spring Washer 10	2	2	2	2
30	80-1415-571-00	Knife Pulley	1	1	1	1
31	80-1020-312-00	Washer 8*30*3.2	1	1	1	1
32	89-1750-080002	Spring Washer 8	1	1	1	1
33	89-1113-080252	Hexagonal Bolt (8T) M8*25	1	1	1	1
34	89-6123-004401	V Belt SB 44	1	1	1	1
35	80-1417-502-00	Knife Pulley Cover	1	1	1	1
36	80-1417-751-00	Rear Guard	1	1	1	1

36	80-1437-751-00	Rear Guard			1	1
37	80-1417-781-10	Rear Flapper	1	1		
37	80-1437-781-10	Rear Flapper			1	1
38	80-1417-785-10	Supporter for Flapper	1	1		
38	80-1437-785-10	Supporter for Flapper			1	1
39	89-1132-060162	Hexagonal Bolt (SW) M6*16	4	4	4	4
40	83-1575-189-00	Nut M6	4	4	4	4
41	89-1113-080162	Hexagonal Bolt (8T) M8*16	1	1	1	1
42	89-1714-080002	Flat Washer 8	1	1	1	1
43	89-1750-080002	Spring Washer 8	1	1	1	1
44	89-1571-080042	Nut M8	1	1	1	1
45	80-1450-709-00	Bolt for Attaching Stay	4	4	4	4
46	89-1714-120002	Flat Washer 12	4	4	4	4
47	83-1450-667-00	Grommet	4	4	4	4
48	89-1714-100002	Flat Washer 10	4	4	4	4
49	89-1750-100002	Spring Washer 10	4	4	4	4
50	89-1571-100042	Nut M10	4	4	4	4



SH60 / SH70

FIG. 7 FRONT WHEEL

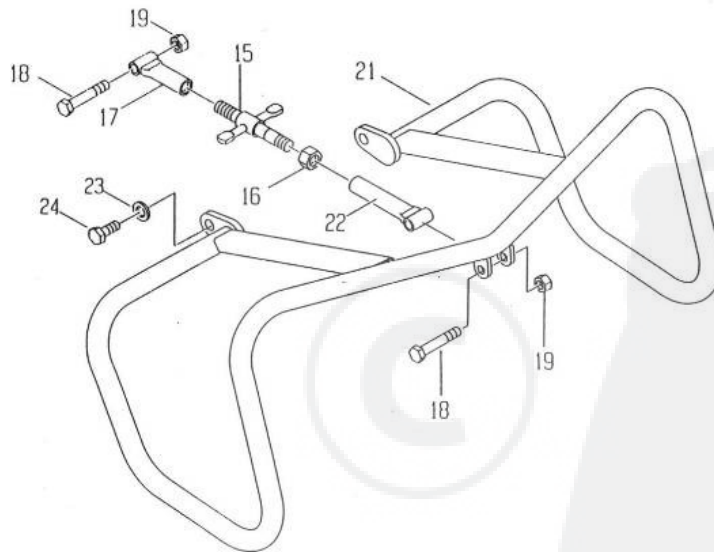
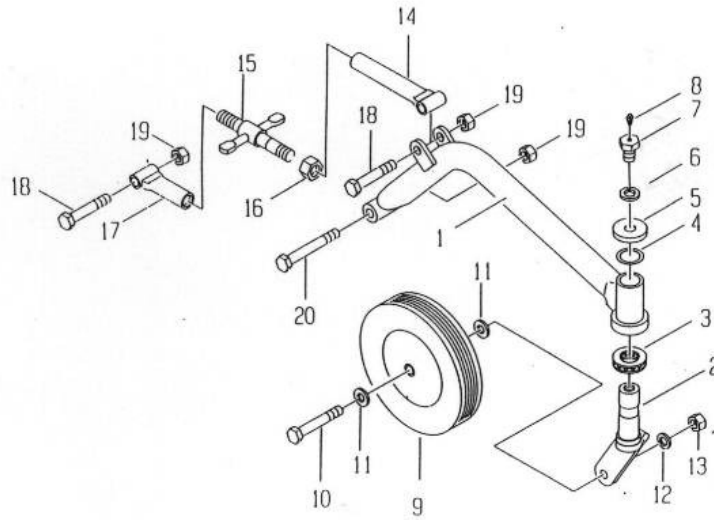

Ref.	Parts No.	Parts Name	Quantity				Remarks
			SH 60A	SH 60S	SH 70A	SH 70S	
1	80-1417-723-00	Front Wheel Arm	1				
1	80-1437-723-00	Front Wheel Arm			1		
2	80-1455-725-00	Front Wheel Fork	1		1		
3	89-3370-051105	Thrust Bearing 51105	1		1		
4	83-1783-376-00	Washer 25*34*1.0	1		1		
5	84-1783-729-00	Dust Cover	1		1		

6	89-1750-140002	Spring Washer 14	1		1		
7	83-1415-975-00	Grease Nipple M6	1		1		
8	84-1783-791-00	Nipple Bolt	1		1		
9	80-1610-727-00	Front Wheel	1		1		
10	89-1113-120752	Hexagonal Bolt M12*75	1		1		
11	89-1711-120002	Flat Washer 12	2		2		
12	89-1750-120002	Spring Washer 12	1		1		
13	89-1511-120042	Hexagonal Nut M12	1		1		
14	80-1417-742-00	Receiver for Adjusting Bolt (R)	1		1		
15	80-1415-743-00	Cutting Height Adjustment Bolt	1	1	1	1	
16	89-1511-160042	Hexagonal Nut M16	1	1	1	1	
17	80-1415-741-00	Receiver for Adjusting Bolt (L)	1	1	1	1	
18	89-1111-120602	Hexagonal Bolt M12*60	2	2	2	2	
19	89-1551-120002	U-Type Nut M12	3	3	3	3	
20	89-1111-120852	Hexagonal Bolt M12*25	1	1	1	1	
21	80-1417-725-00	Skid Arm		1			
21	80-1437-725-00	Skid Arm				1	
22	80-1415-742-00	Receiver for Adjusting Bolt (R)		1		1	
23	83-1630-342-00	Washer 16*26*2.3		2		2	
24	80-1417-714-00	Axle for Attaching Skid Arm		2		2	

