

SINCE 1839

**BRINLY**

SINCE 1839

**BRINLY**

# OWNER'S MANUAL

## 15 & 25 GALLON TOW-BEHIND LAWN SPRAYER

SPRAYER MODEL:

**ST-150 BH**

**ST-250 BH**

- Assembly
- Installation
- Operation
- Repair Parts

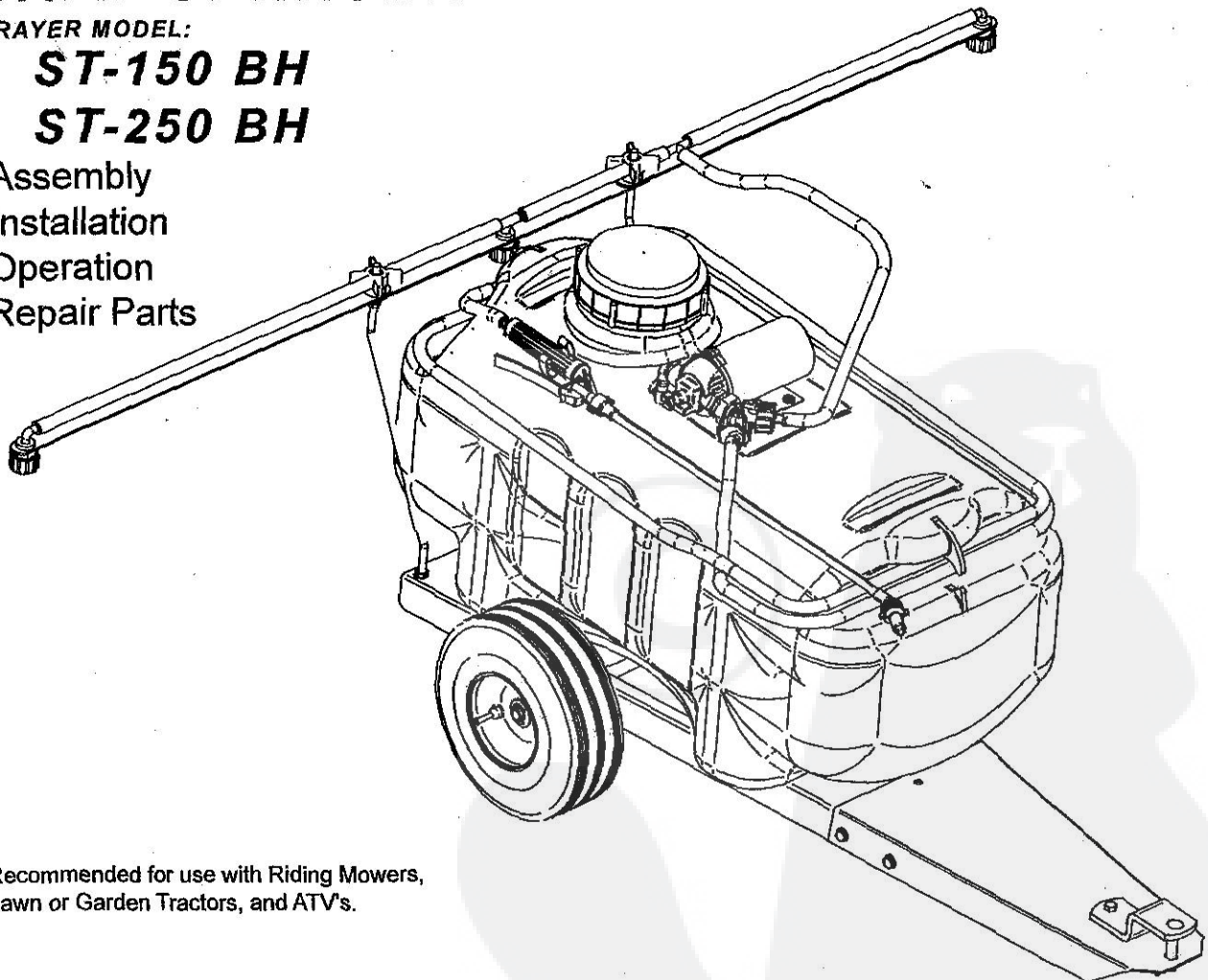

Recommended for use with Riding Mowers,  
Lawn or Garden Tractors, and ATV's.

For the latest product updates and setup tips:

Visit us on the web!  
[www.brinly.com](http://www.brinly.com)

**Important:** This manual contains information for the safety of persons and property. Read it carefully before assembly and operation of the equipment!

CONGRATULATIONS on your new Brinly-Hardy Sprayer! Your Sprayer has been designed, engineered and manufactured to give you the best possible dependability and performance.

Should you experience any problem you cannot easily remedy, please do not hesitate to contact our **Customer Service Department** toll-free at **1-877-728-8224**.

## CUSTOMER RESPONSIBILITIES

Please read and retain this manual. The instructions will enable you to assemble and maintain your sprayer properly. And please, always observe the "Safety Rules". Read and Observe the "Safety Rules".

Follow a regular schedule in maintaining, caring-for and using your Brinly Sprayer.

## TABLE OF CONTENTS

SAFETY RULES .....	2
HARDWARE.....	3
REFERENCE.....	4,6
PARTS LIST.....	5,7
ASSEMBLY.....	8-10
ELECTRICAL CONNECTION.....	10
MAINTENANCE.....	3
OPERATION.....	10
PRODUCTS.....	11
WARRANTY.....	11

## RULES FOR SAFE OPERATION

- Know your pulling equipment's controls and safety features. **READ YOUR EQUIPMENT OWNER'S MANUAL FOR SAFE OPERATION OF YOUR EQUIPMENT!**
- Do not allow children to operate the vehicle. Do not allow adults to operate without proper instruction or without having read the Owner's Manual.
- Do not carry passengers. Keep children and pets a safe distance away.
- Always wear substantial footwear. Do not wear loose fitting clothing that can get caught in moving parts.
- Keep your eyes and mind on your actor/attachment and area being covered. Do not let other interests distract you.
- Stay alert for holes in the terrain and other hidden hazards.
- Do not drive close to creeks, ditches and public highways.
- Watch out for traffic when crossing or near roadways.
- When using any attachment, don't allow anyone near the vehicle while in operation.
- Keep the vehicle and attachment in good operating condition and keep safety devices in place.
- Keep all nuts, bolts and screws tight to be sure the equipment is in safe working condition.
- The vehicle and attachment should be stopped and inspected for damage after striking a foreign object. The damage should be repaired before restarting and operating the equipment.
- See tractor equipment Owner's Manual for safe operation of the equipment.

## CAUTION!

Always add chemicals to water, not water to chemicals!

**DO NOT** use flammable chemicals.

Keep the water hose used to fill the tank out of the chemicals, failure to do this could result in a contaminated hose system.

Use and Properly dispose of chemicals in accordance with the chemical manufacturers instructions.

Never empty tank in a drain or near a lake or stream.

Always be sure to wear protective eyewear (goggles) when filling your sprayer and when spraying chemicals.

Wear protective clothing that is close fitting and that covers your arms and legs.

Follow chemical manufacturer's instructions.

**DO NOT** permit children on or around the Sprayer while in use.

Always operate your Sprayer within the speed limit for which it was designed ( 2 - 5 m.p.h.).

When backing - carefully back straight to avoid jackknifing, which could result in damage to equipment.

Your Sprayer when filled with 15 Gallons of water will weigh approximately 150 pounds.

**ALLOW FOR EXTRA STOPPING DISTANCE!**

This product is not designed for use in sand or gravel, or to carry extra weight.



This symbol will help to point out important safety precautions throughout this manual. It means - ATTENTION! BECOME ALERT! Your safety is involved.



**REFERENCE**

**Tools Required for Assembly:**

- 1/2" wrench (2)
- 7/16" wrench (2)
- Pliers
- Tape Measure

**OPERATION ( U.S. - 1.8 gpm Pump)**

**APPLICATION RATE - WAND**

Understanding the following information about your sprayer will help to calibrate the application rate. The sprayer operates at a fixed pressure of 60psi. This results in actual spraying time of 30 minutes(using the handgun) for the 25 gallon unit, and 18 minutes for the 15 gallon unit.

**APPLICATION RATE - BOOM**

Product	Gallons Per Acre			
	mph			
	2	3	4	5
ST-250	56.5	37.5	28.0	22.5
ST-150	69.5	46.0	34.5	27.5

Product	Gallons per 1000 Square Feet			
	mph			
	2	3	4	5
ST-250	1.3	0.9	0.6	0.5
ST-150	1.6	1.1	0.8	0.6

**TRACTOR REQUIREMENTS**

The Brinly Sprayer requires towing equipment with a 12-volt battery and charging system, and a drawbar hitch in order to properly operate the Brinly Sprayer.

The towing equipment should have operable brakes capable of controlling the loaded Sprayer and tractor.

**CALIBRATION OF SPEED**

By measuring off a distance of 50 or 100 feet, the speed of the tractor can be calibrated by selecting a gear and throttle position to cover the prescribed distance in the specified time as shown:

Speed mph	Seconds required to travel:	
	50 feet	100 feet
2	17	34
3	11	22
4	9	17
5	7	14

**CALCULATION PROCEDURE FOR SPRAYER APPLICATION**

Chemical labels normally show application rates in gallons per acre or gallons per square feet. Using the following method, one can determine the appropriate amount of water to use and speed to travel to adequately follow the manufactures recommended instructions.

1. Based on the size of your yard, select the amount of water to be used. Use the formula:

Application Rate (from the table) x Area to be sprayed = Amount of water

**Example 1**

Sprayer= ST-250  
Yard Size= 4 acres

Using the table and the above formula:

56.5 gal/ acre x 4acres= 226.6 gal@ 2mph  
37.5 gal/ acre x 4acres= 149.6 gal@ 3mph  
28.0 gal/ acre x 4acres= 112.0 gal@ 4mph  
22.5 gal/ acre x 4acres= 90.0 gal@ 5mph

**Example 2**

Sprayer= ST-250  
Yard Size= 20,000 sf

1.3 gal/ 1000 x 20,000sf= 26 gal@ 2mph  
0.9 gal/ 1000 x 20,000sf= 18 gal@ 3mph  
0.6 gal/ 1000 x 20,000sf= 12 gal@ 4mph  
0.5 gal/ 1000 x 20,000sf= 10 gal@ 5mph

2. Choose the speed / amount of water you want to use.

**Example 1**

A comfortable speed for a lawn tractor is 3 mph.

**Example 2**

Since 18 gallons can be done with only one filling:

Choice = 149.6 ~ 150 gal@ 3mph

Choice = 18 gallons @ 3mph

3. Determine how many tanks are required to complete the total job:

Amount of Water / Tank Capacity = Number of tanks from step 1

If the number of tanks is less than 1.0 use 1.0

**Example 1**

150 gal/ 25 = 6.0 tanks

**Example 2**

18 gal/ 25 = 0.7 tanks use 1.0 tank

4. Determine how much chemical is to be used:

Rate from manufactures label x Area to be Sprayed = Amount of chemical req.

**Example 1**

Label = 20 ounces/acre

20 oz. x 4 acres = 80 oz.

**Example 2**

Label = 1/2 pint/ 1000 sq. ft.

1/2pt/1000 x 20,000 sf = 10 pints

5. Determine how much chemical per tank:

Amount of chemical (from step 4) x # of Tanks (from step3) = Amount of chemical per tank

**Example 1**

80oz./ 6.0 tanks = 13.3 oz./tank

**Example 2**

10 pints/ 1 tank = 10 pints

**SPRAYER OVERLAP**

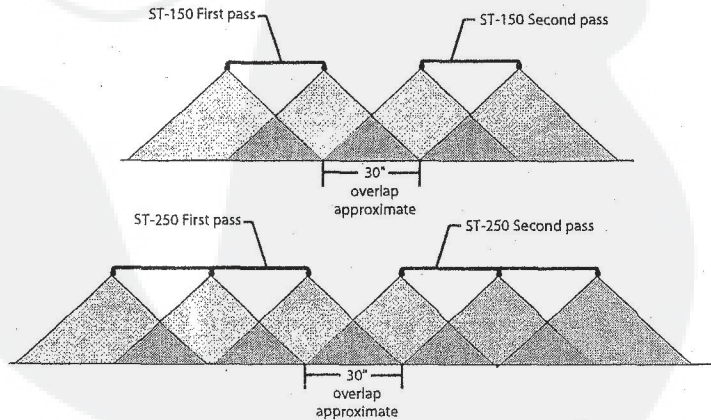

Parts Reference (Tank Assembly)

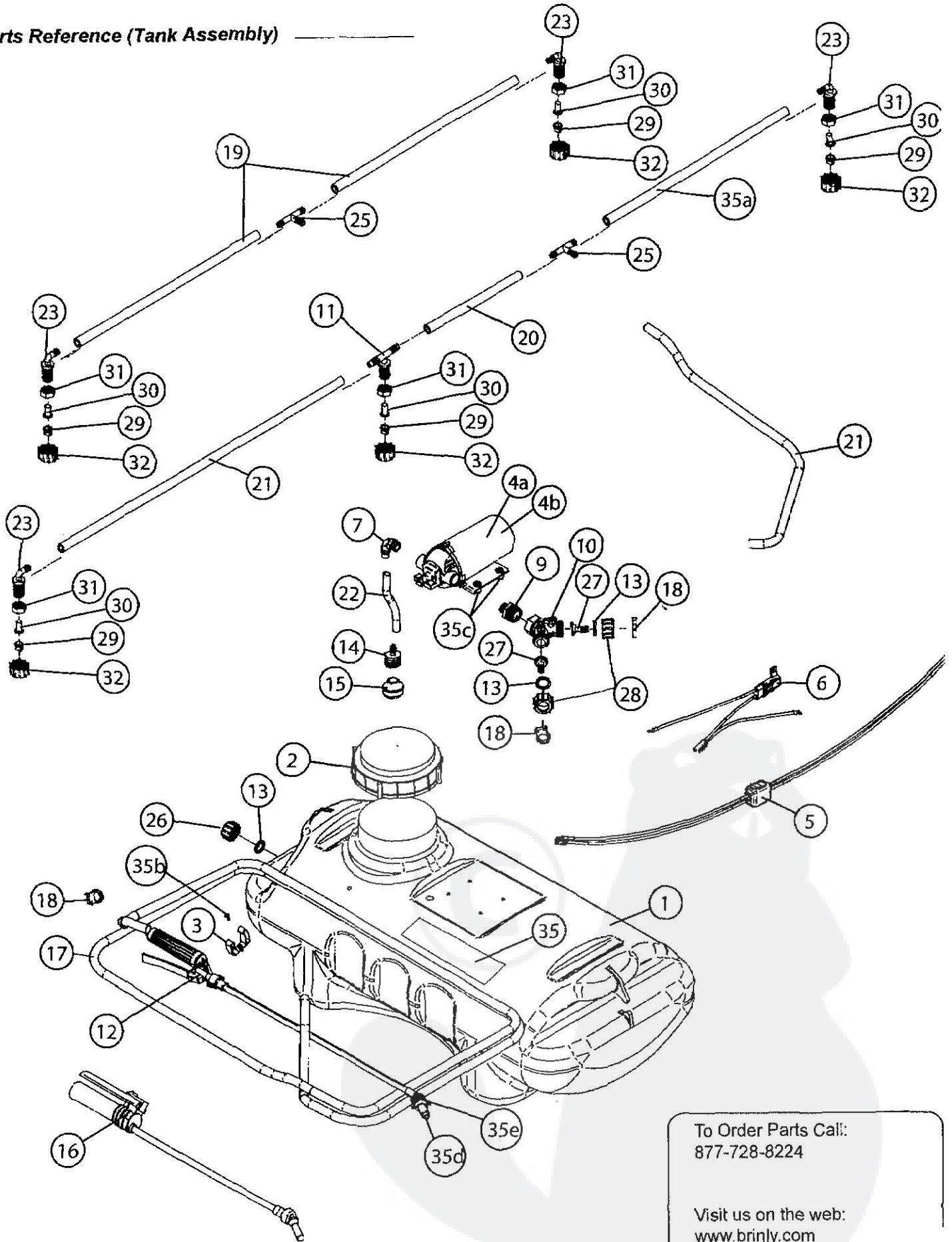

To Order Parts Call:  
877-728-8224

Visit us on the web:  
[www.brinly.com](http://www.brinly.com)



## Parts List (Tank Assembly)

Ref. No.	Part No.		Description	Qty.
	ST-150	ST-250		
1.	B-6026	B-6025	Sprayer Tank,	1
2.	B-6028	B-6028	Tank Cap	1
3.	B-6511	B-6511	Clip, Gun Holder w/screw(22M0606P)	1
4a.	B-6027	B-6027	Pump, U.S. only	1
4b.	B-6279	B-6279	Pump, "CE" Certified Export	1
5.	B-6030	B-6030	Wiring Harness w/switch	1
6.	B-6031	B-6031	Wiring Harness, Battery Connection	1
7.	B-6046	B-6046	Elbow 90deg., 3/8" M.P.T.x 3/8" H.B.	1
8.	B-6047	B-6047	Hose Clamp	2
9.	B-6513	B-6513	Nipple, Reducing, 1/2" M.P.T. x 3/8" M.P.T.	1
10.	B-6512	B-6512	Tee, 1/2" F.M.P.T.	1
11.		B-6044	Nozzle Body, Tee w/ 3/8" HB	1
12.	B-6400	B-6400	Spray Gun( B-6583 - Tip only for service)	1
13.	B-6054	B-6054	Washer, Black Vinyl 1" OD x 3/4" ID	3
14.	B-6598	B-6598	Hose Barb, 1/4" M.P.T.x 3/8" H.B.	1
15.	B-6597	B-6597	Strainer, 1/4", #40 mesh	1
16.	B-6029	B-6029	Hand-Gun (B-6029A - Tip only for service)	1
17.	B-6033	B-6033	Hose, 3/8" ID x 12'	1
18.	B-6047	B-6047	Hose Clamp	3
19.	B-6037		Hose, 3/8" ID x 15"	2
20.		B-6036	Hose, 3/8" ID x 7-1/2"	1
21.	B-6034	B-6034	Hose, 3/8" ID x 30"	1 or 2
22.	B-6088	B-6087	Hose, 3/8" ID	1
23.	B-6043	B-6043	Nozzle Body, 90deg, 3/8" H.B.	2
24.	B-6045	B-6045	Hose Barb, Tee, 3/8" x 3/8"	1
25.	B-6578	B-6578	Drain Cap	1
26.	B-6055	B-6055	Hose Barb, Flat Seat, 3/8" H.B.	2
27.	B-6056	B-6056	Nut, Hose Swivel, 3/4" F.G.H.T.	2
* 28.	B-6514	B-6514	Tip, Sprayer	2 or 3
* 29.	B-6040	B-6040	Strainer, Nozzle	2 or 3
* 30.	B-6041	B-6041	Jamb Nut, Nozzle Fitting	2 or 3
* 31.	B-6042	B-6042	Nut, Tip Fitting	2 or 3
32.	B-6020	B-6020	Caution Decal	1
35a.		B-6035	Hose, 3/8" ID x 22"	1
25b.	22M0606P	22M0606P	Screw, #10-24 x 3/8"	1
35c.	22M0616P	22M0616P	Screw, #10-24 x 1"	4
35d.	B-6583	B-6583	Tip, Hand Wand	1
35e.	B-6584	B-6584	Nut, Hand Wand	1

\* - Bag "B" (Z-1704) for ST-250

\* - Bag "B" (Z-1706) for ST-150

**Parts Reference (Trailer Assembly)**

To Order Parts Call:  
877-728-8224

Visit us on the web:  
[www.brinly.com](http://www.brinly.com)

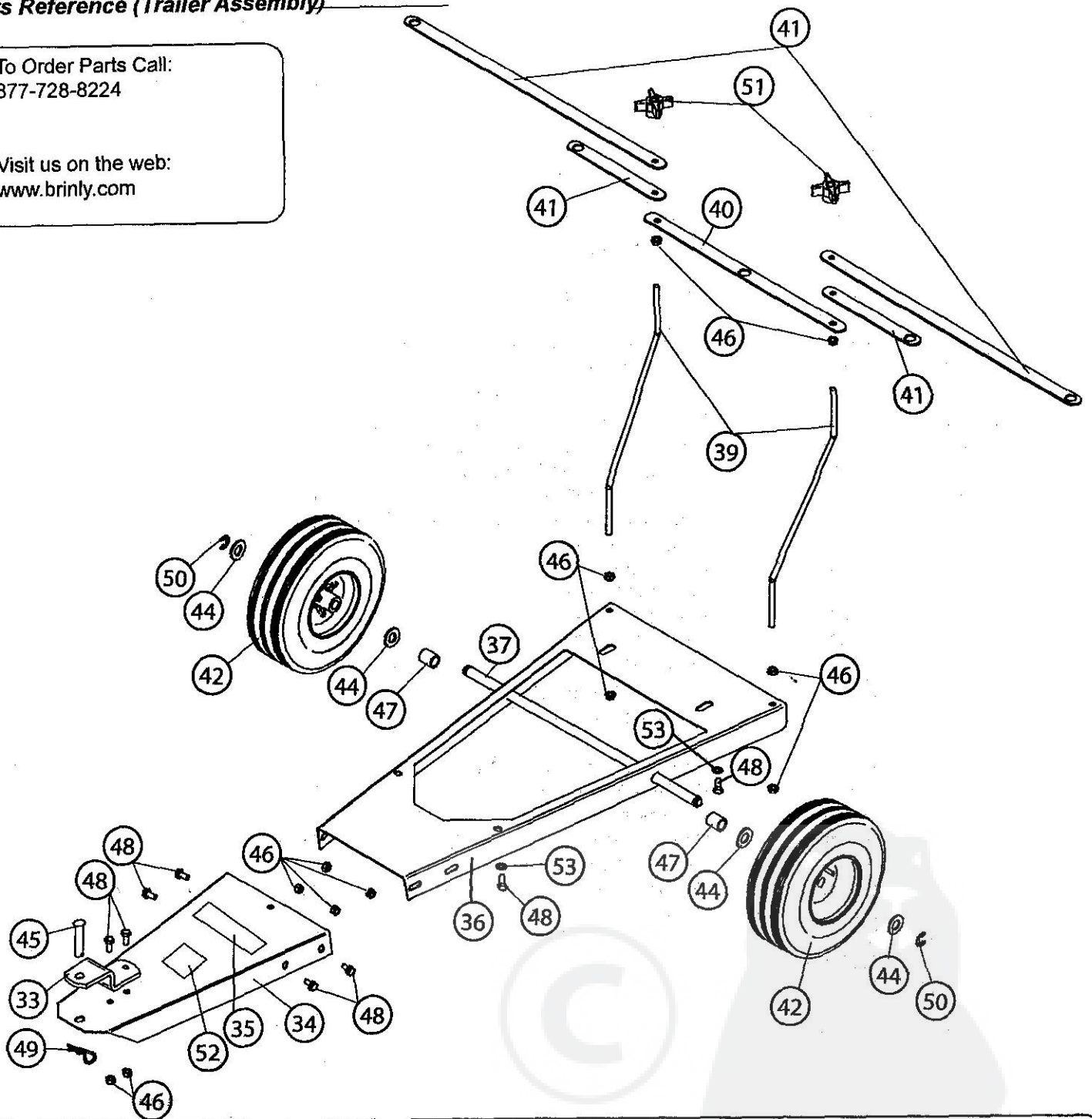

**NOTES**



## Parts List (Frame Assembly)

Ref.No.	ST-150	ST-250	Description	Qty.
33.	B-3034-10	B-3034-10	Clevis	1
34.	B-6322F-10	B-6322F-10	Drawbar	1
35.	B-5922	B-5922	Logo Decal	1
36.	B-6322R-10	B-6322R-10	Base	1
37.	B-5684	B-5684	Axle	1
39.	B-5687	B-5687	Boom Support	2
40.	B-5688-10	B-5688-10	Boom Bar	1
41.	B-5689-10	B-5690-10	Boom Extension	2
42.	B-5692	B-5692	Wheel	2
** 44.	45M2121P	45M2121P	5/8" Flat Washer	4
** 45.	B-3861	B-3861	Hitch Pin	1
** 46.	B-4355	B-4355	5/16" Whiz Lock Nut	12
** 47.	B-5691	B-5691	Axle Spacer	2
** 48.	B-5695	B-5695	5/16" x 5/8" Hex Flange Bolt	10
** 49.	D-146P	D-146P	Hitch Pin Cotter	1
** 50.	F-577	F-577	5/8" E-Ring	4
** 51.	F-782	F-782	Knob	2
52.	R-1946	R-1946	Caution Decal	1
53.	R-618	R-618	Washer, Special	4

\*\* - Bag "A" (Z-1705)

**Figure 1.**

Qty. 4  
(48) Hex Flange Bolt,  
5/16" x 5/8"



Qty. 4  
(46) Whiz Lock Nut, 5/16"

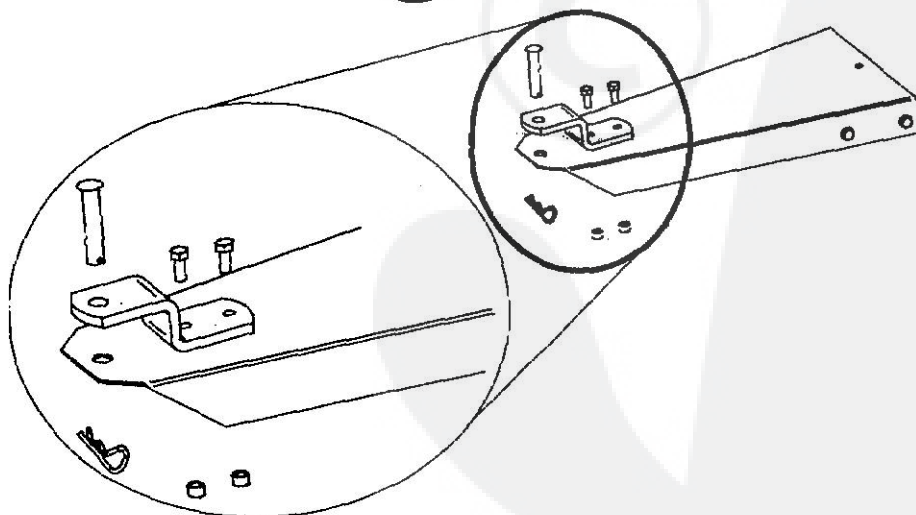
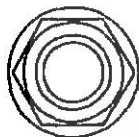

Figure 2.

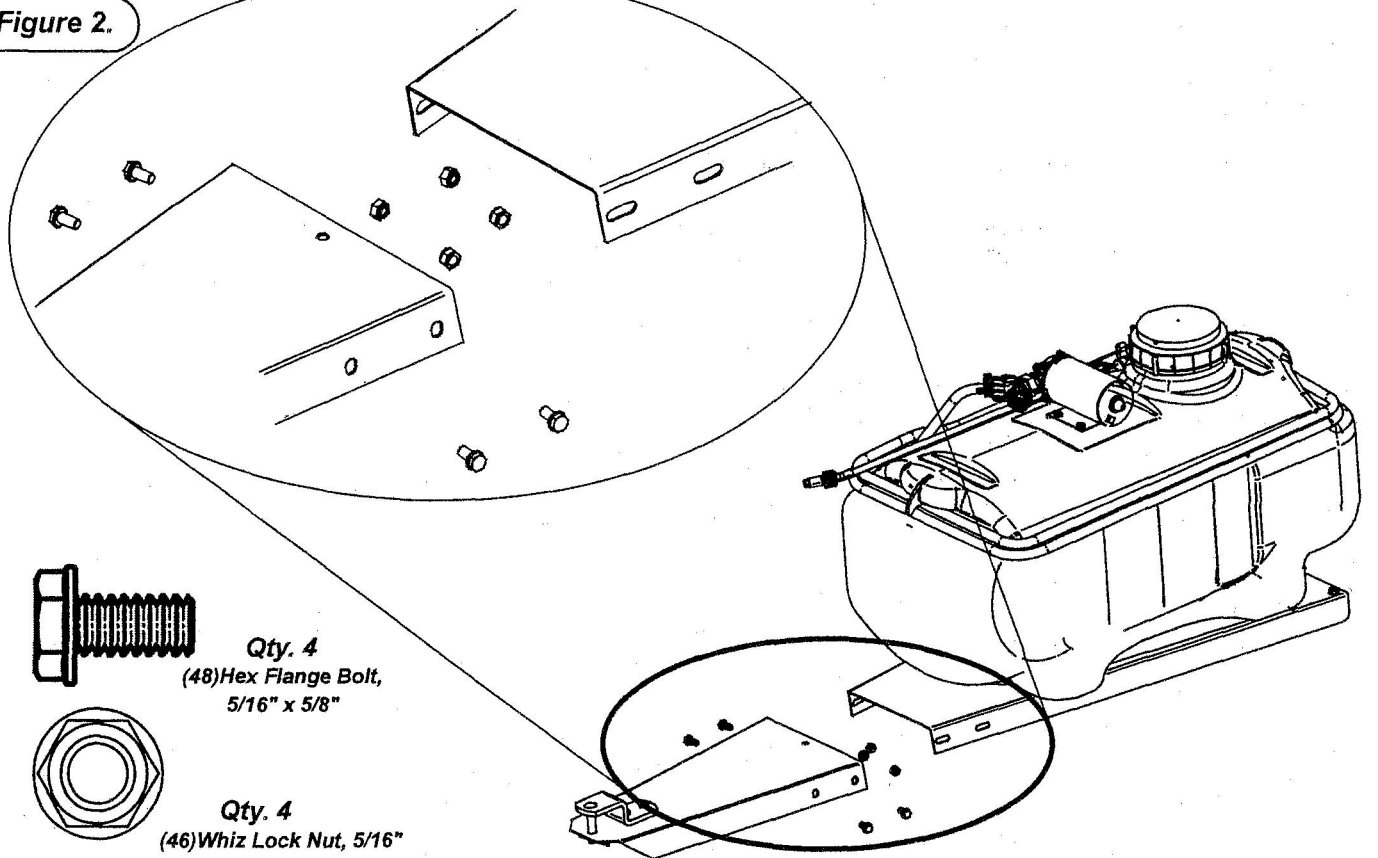

Figure 3.

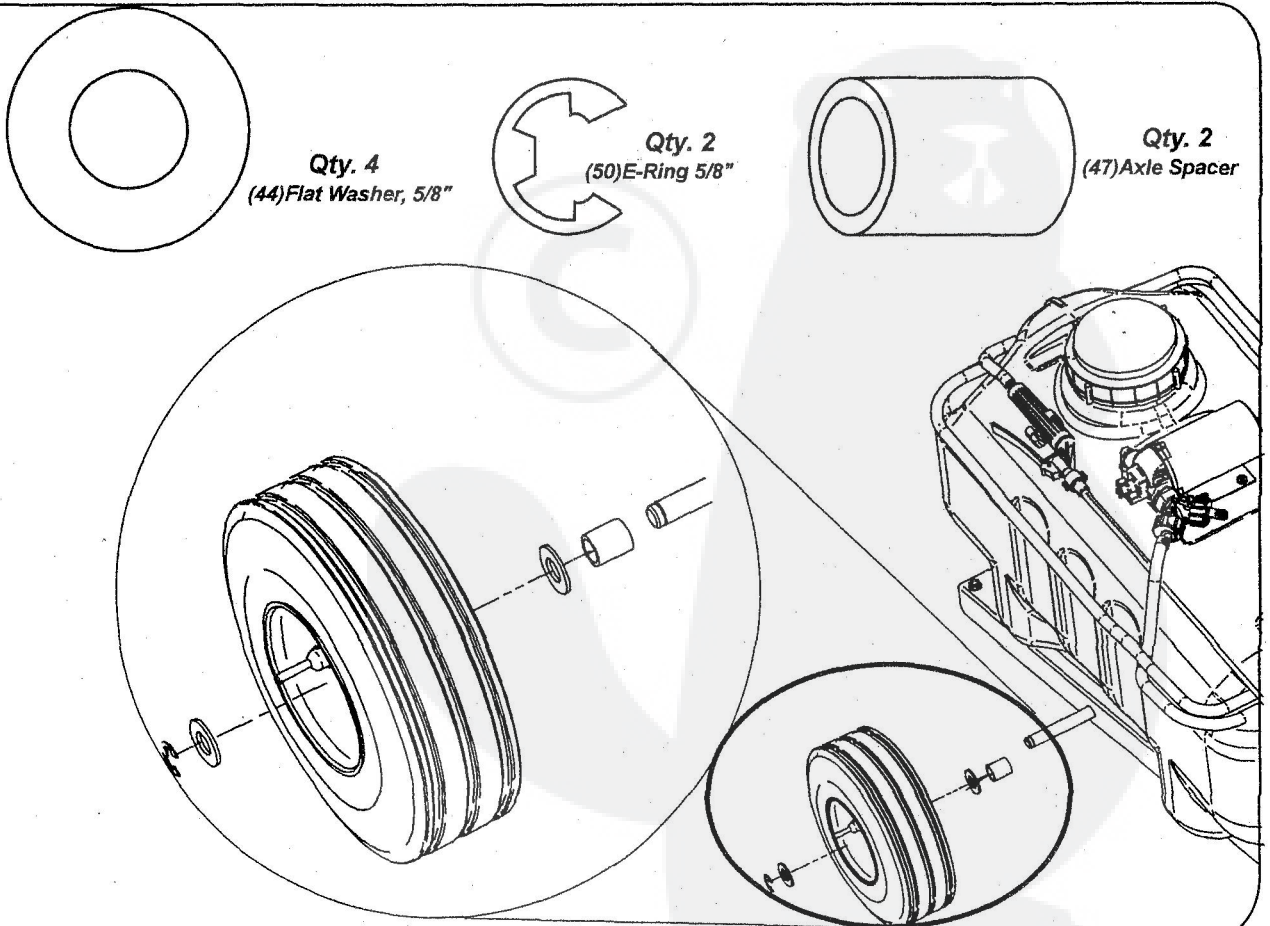



Figure 4.

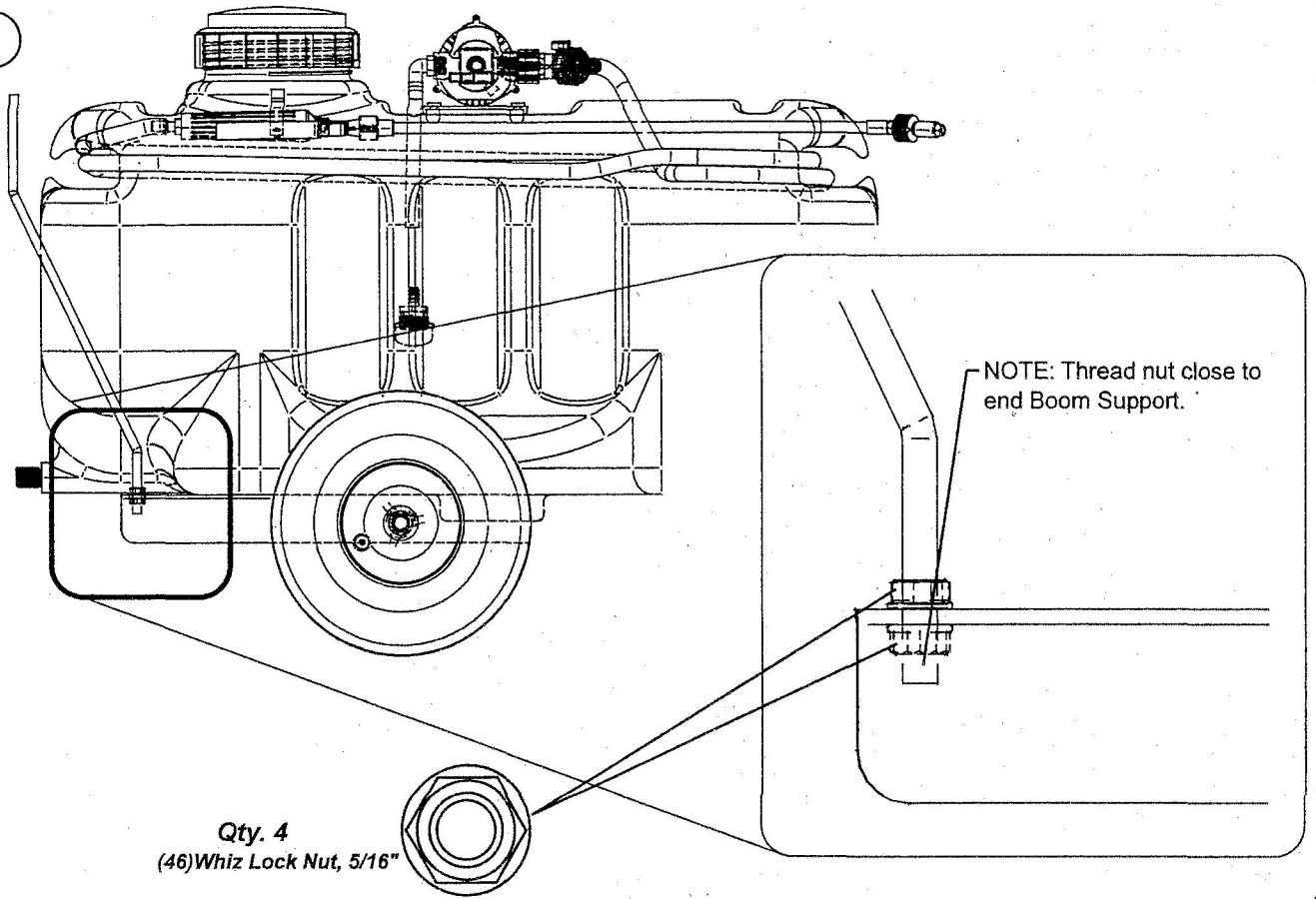
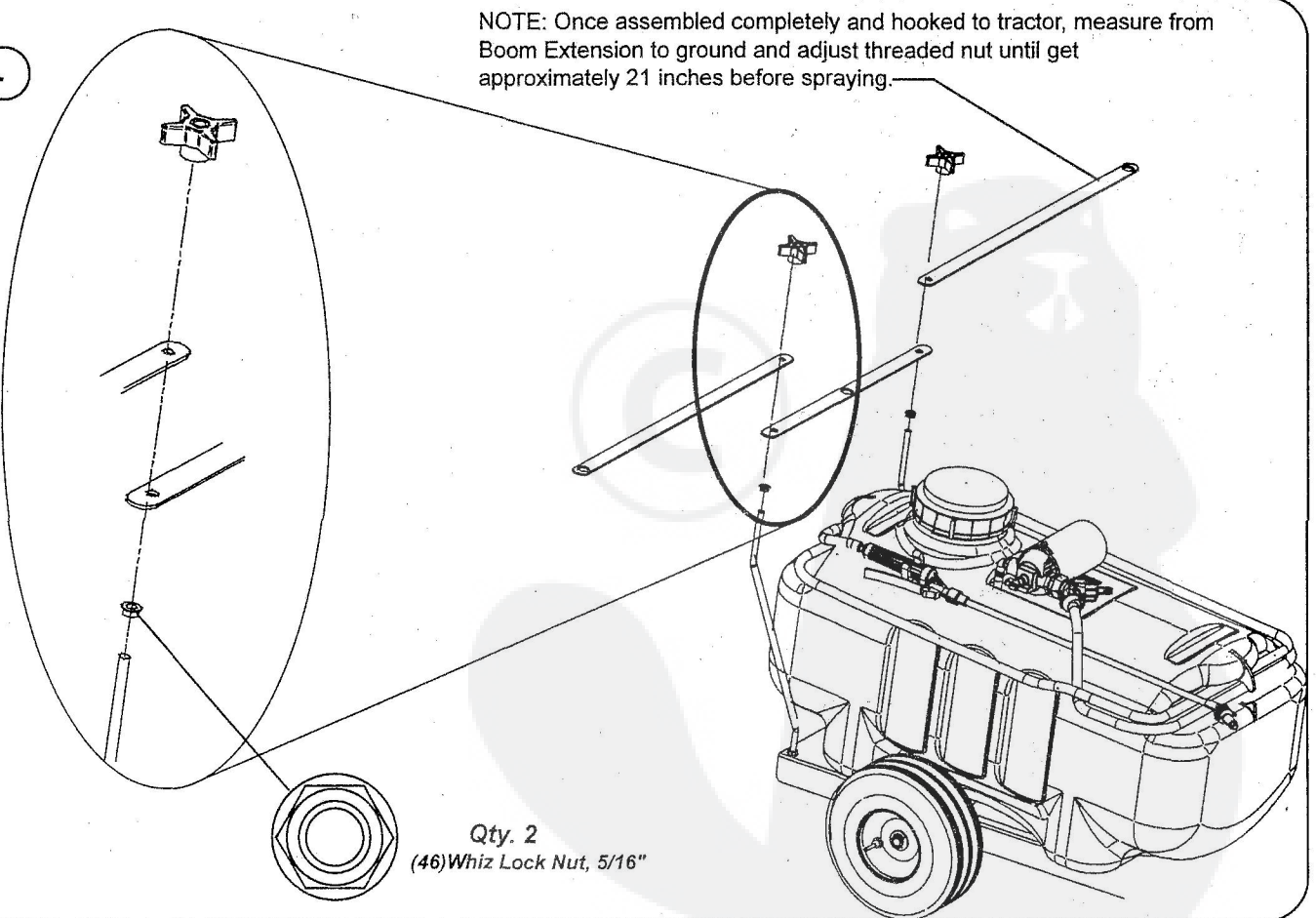
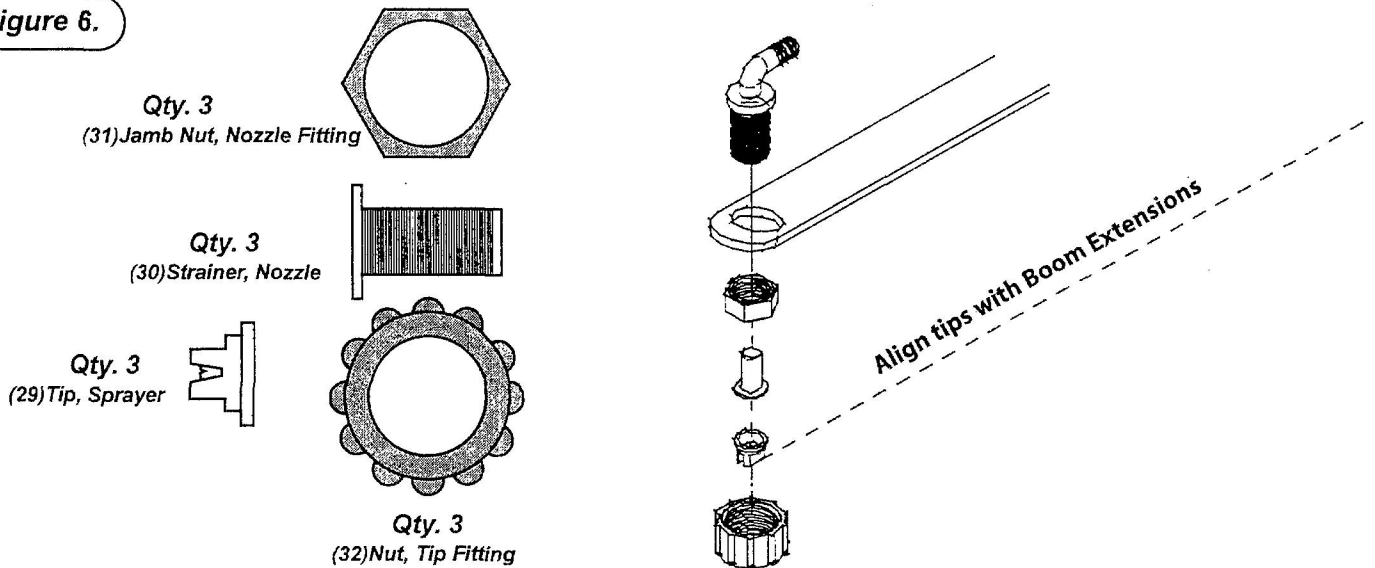

Figure 5.



**Figure 6.**



## MAINTENANCE

The key to years of trouble-free service is to keep your Sprayer clean and dry.

Never allow wet material to remain in Sprayer for extended periods of time.

Occasionally check all moving parts for free movement and, if necessary, lubricate with oil.

Should rust develop, sand lightly and then paint area with enamel.

Periodically check all fasteners for tightness. Drain chemicals after each use. Once drained, flush system clean.

For Winter Storage: Flush out entire system, and store dry with no liquid in the pump to prevent freezing and breakag

## SPRAYER TIPS

Once assembled completely and hooked to tractor, measure from Boom Extension to ground and adjust threaded nut until get approximately 21 inches before spraying.

NEVER let the Sprayer operate in one spot. Turn Sprayer off to avoid over application of chemicals.

Turn Sprayer off during turns to avoid double spray.

Fill Sprayer where spills cannot harm grass.

Follow spray material manufacturer's recommended mixing instructions, concentrations, and application rate.

Be sure to follow chemical manufacturers disposal and safety requirements.

When Backing up, carefully back STRAIGHT to avoid "jack-knifing", which can cause damage to your equipment.

Remember to always add chemicals to water, not water to chemicals. Chemicals have tendency to splash and may be harmful.

## ELECTRICAL CONNECTIONS

Your Brinly Sprayer uses 12-volt D.C. power.

Attach the Red Lead to the Positive terminal of your battery. Attach the Black Lead to the Negative terminal of your battery.

Caution should always be exercised whenever working on or around batteries.

Heavy Gloves and Eye Protection should be worn when making connections to the battery.

Make sure to periodically check the fuse within the wiring harness.



**Caring for the quality of your lawn  
with the products from  
Brinly-Hardy Company**

CALL OR EMAIL US FOR A FREE BROCHURE

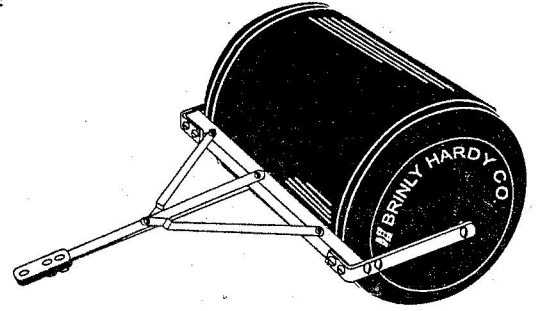
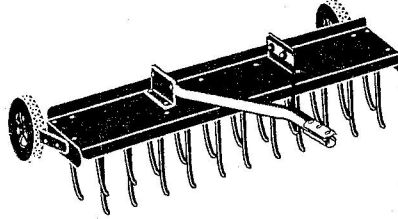
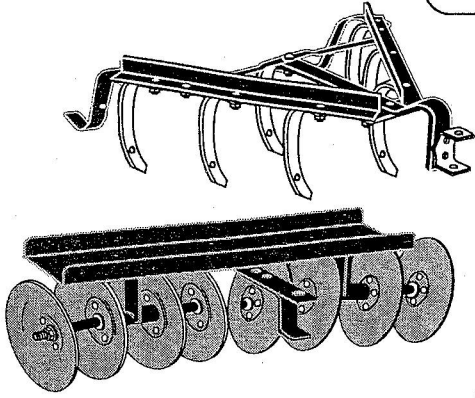

Brinly's garden tractor items offer the largest selection to turn your garden tractor into a year-round tool. We have box scrapers, blades, cultivators, disk harrows, and even a plow! Remember that a sleeve hitch is required to hook up these items to your garden tractor.

If left alone, matted layers of thatch and large grass clippings can form on your lawn which prevents air circulation and breeds disease. Our patented design Dethatcher with spring steel tines gently comb thatch and clippings to the surface where they can be re-mulched, collected, or left exposed to the elements to break down.

No more rust or dents with these poly lawn rollers. These units are much easier to deal with than the steel versions. They have rounded end caps that won't tear or gouge the lawn when turning. Erase the harmful effects of front heaving and moles, or pack down newly sown seed or sod.

**Limited Warranty**

Brinly-Hardy Company warrants only to the original retail purchaser that this product will remain free of defects in workmanship and materials under normal use and service for a period of two (2) years (NOTE: ninety (90) days for commercial or rental use) commencing with the date of purchase.

Any parts found to be defective within the warranty period will be replaced, with proof of date of purchase, at Brinly-Hardy Company's expense. Our obligation under this warranty is expressly limited to replacement or repair, at our option of parts, which are defective in material or workmanship within thirty (30) days of receipt of the parts. This warranty does not apply to damage caused by unreasonable use, including failure to provide necessary maintenance, nor does it apply to any transportation or labor charges.

WE MAKE NO OTHER EXPRESS WARRANTY NOR IS ANYONE AUTHORIZED TO MAKE ANY ON OUR BEHALF. ANY IMPLIED OR STATUTORY WARRANTIES, INCLUDING ANY WARRANTY OF MERCHANTABILITY OR FITNESS FOR A PARTICULAR PURPOSE, ARE LIMITED TO THE DURATION OF THIS WRITTEN WARRANTY. WE SHALL NOT BE LIABLE FOR CONSEQUENTIAL OR INCIDENTAL DAMAGES OF ANY KIND.

MADE IN THE U.S.A.  
BRINLY-HARDY COMPANY TOLL-FREE 1-877-728-8224

Register Online at: [www.brinly.com](http://www.brinly.com)

**Quality Insurance**

Dear Customer,  
We are very proud of our quality and endeavor to produce each product to meet high standards. Should your purchase not meet your expectations, we have a Quality Insurance Policy.

If you purchase a product and a part is missing or defective, please inform us of the problem on the "Comments" section of the Warranty Registration Card in this manual or online, or feel free to contact us toll free at 1-877-728-8224. PLEASE DO NOT RETURN THE PRODUCT TO THE STORE.

We will make every effort to ship a new replacement part to you within 24 hours at no charge.

Thank you,

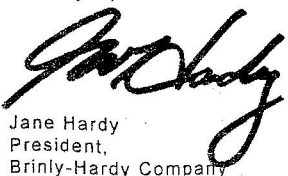
  
Jane Hardy  
President,  
Brinly-Hardy Company

**WARRANTY REGISTRATION CARD**

To register your new product for warranty, please complete and return this card.

Name: \_\_\_\_\_

Address: \_\_\_\_\_

City: \_\_\_\_\_ State: \_\_\_\_\_ Zip: \_\_\_\_\_

Phone: \_\_\_\_\_

Product Purchased: \_\_\_\_\_ Model#: \_\_\_\_\_

Packing# (on carton): \_\_\_\_\_

Where purchased: \_\_\_\_\_ Date: \_\_\_\_\_

Type of Tractor Owned: Make: \_\_\_\_\_

Model: \_\_\_\_\_

HP: \_\_\_\_\_

Size of Lawn:  1/4-1/2acre  1/2-1acre  1-5 acre  5+

Do you garden?  Use a tractor?  Tiller?

Your Occupation? \_\_\_\_\_

Your Email Address? \_\_\_\_\_