

SINCE 1839

**BRINLY**

# OWNER'S MANUAL

## **PUSH/TOW POLY CART**

MODEL:

**PC-100 BH**

- Assembly
- Installation
- Operation
- Repair Parts

For use with Riders  
and Lawn/Garden Tractors

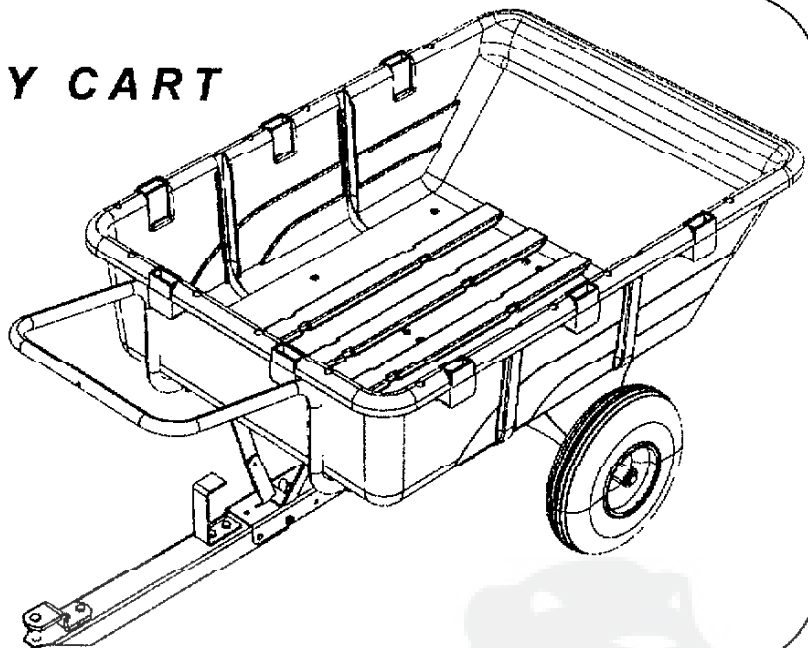

For the latest product updates and setup tips:

Visit us on the web!  
[www.brinly.com](http://www.brinly.com)

**Important:** This manual contains information for the safety of persons and property. Read it carefully before assembly and operation of the equipment!

L-1689 01

CONGRATULATIONS on your new Brinly-Hardy Cart! Your Cart has been designed, engineered and manufactured to give you the best possible dependability and performance.

Should you experience any problem you can not easily remedy, please do not hesitate to contact our knowledgeable customer service department toll-free at 1-877-728-8224. We have competent, well trained technicians and the proper tools to service or repair your Cart.

Please read and retain this manual. The instructions will enable you to assemble and maintain your Cart properly. And please, always observe the "Safety Rules".

### CUSTOMER RESPONSIBILITIES

Read and Observe the "Safety Rules".



This symbol will help to point out important safety precautions throughout this manual. It means - ATTENTION! BECOME ALERT! Your safety is involved.

Follow a regular schedule in maintaining, caring-for and using your Brinly-Hardy Cart.

### TABLE OF CONTENTS

SAFETY RULES .....	2	MAINTENANCE .....	8
HARDWARE.....	3	OPERATION .....	8
PARTS LIST .....	4	PRODUCTS .....	9
PARTS REFERENCE.....	5	WARRANTY.....	9
ASSEMBLY .....	6-7		

### RULES FOR SAFE OPERATION



- Know your tractor controls and how to stop quickly, READ THE TRACTOR OWNER'S MANUAL.
- Do not allow children to operate the vehicle, do not allow adults to operate without proper instruction or without having read the owner's manual.
- Do not carry passengers. Keep children and pets a safe distance away.
- Always wear substantial footwear. Do not wear loose fitting clothing that can get caught in moving parts.
- Keep your eyes and mind on your tractor/attachment and area being covered. Do not let other interests distract you.
- Stay alert for holes in the terrain and other hidden hazards.
- Do not drive close to creeks, ditches and public highways.
- Watch out for traffic when crossing or near roadways.
- When using any attachment, don't allow anyone near the vehicle while in operation.
- Keep the vehicle and attachment in good operating condition and keep safety devices in place.
- Keep all nuts, bolts and screws tight to be sure the equipment is in safe working condition.
- The vehicle and attachment should be stopped and inspected for damage after striking a foreign object. The damage should be repaired before restarting and operating the equipment.



- See tractor equipment owner's manual for safe operation of the equipment
- When backing - carefully back straight to avoid jack knifing, which could result in damage to equipment.



- Use correct number of weights on tractor. The weight of the tractor and operator MUST BE MORE than the weight of the cart and load.
- Maximum load is 650 lbs



- DO NOT tow this cart behind a motor vehicle. (Car, Truck, ATV) Max speed 5 mph.
- Maintain cart tires inflated to 30 P.S.I.

### OPERATING HINTS

To Dump a load:

1. Stop the tractor, lock the parking brake and stop the engine.
2. Release the lock bar and raise the handle carefully to tilt the bed to the full dump position.

To convert the cart from pull to push(push to pull is reversed)

1. Cart must be empty.
2. Disconnect cart from tractor.
3. Tilt cart without releasing lock bar(11).
4. Remove hairpin cotter(30) from clevis pin(26) and remove the clevis pin.
5. Rotate the front towbar assembly(8) 180 degrees towards the axle.
6. Reinstall the clevis pin and cotter(from step 4)in the rear hole. (located on the rear towbar between the 3/8" hex bolt and the axle.

**HARDWARE REFERENCE**

This page is for reference use only  
All items shown full size unless otherwise specified

**Hardware Bag (Part No. Z-1734)**



**12**  
(4) 1/4" x 2" RD HD Mach. Screw

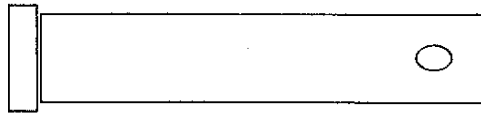

**22**  
(10) Hitch Pin (1/2" x 2 1/2" But. HD)



**23**  
(1) Retaining Ring 3/4"



**13**  
(10) 5/16 x 1" RD HD Mach. Screw



**24**  
(1) 5/16"-18 Nylon Lock Nut



**14**  
(4) 5/16" x 3/4" Hex Bolt

**25**  
(1) 3/4" Mach. Bushing

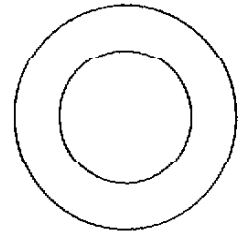

**26**  
(1) Clevis Pin, 5/16" x 3-1/2"

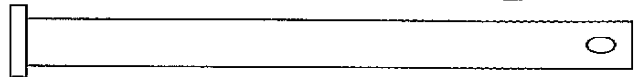

**15**  
(10) 1/4"-20 Reg Hex Nut



**27**  
(1) Hex Bolt, 3/8" x 3-1/2" (not to scale)



**16**  
(10) 5/16"-18 Reg Hex Nut



**28**  
(2) 3/8"-16 Hex Nut Sems

**17**  
(4) 1/4" Med Lock Washer

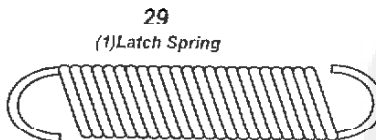

**29**  
(1) Latch Spring

**30**  
(1) Hair Pin Cotter .08" x 3/16"

**18**  
(10) 5/16" Med Lock Washer

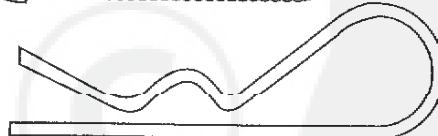

**31**  
(1) Hair Pin Cotter 1/8"

**19**  
(4) 1/4" SAE Flat Washer



**20**  
(10) 5/16" SAE Flat Washer



**21**  
(1) 3/8" Hex Lock Nut

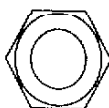

**Tools Required for Assembly:**

- \* 1/2" wrench (2)
- \* 9/16" wrench (2)
- \* Pliers
- \* Flat Head Screwdriver

**Hardware Bag (Part No. Z-1435-1D)**



**32**  
(2) Spacer  
(not shown to scale)

**Parts Reference**

**Parts List**

REF. NO.	PART NO.	DESCRIPTION	QTY.
1	B-3034-10	Clevis	1
2	B-3308P-10	Axle Support	1
3	B-3620-10	Lock Docket	1
4	B-4261	Axle	1
5	B-4600	Wheel Assembly	2
6	B-6218-BH	Poly Bed	1
7	D-6219-10	Towbar, Rear	1
8	B-6220-10	Towbar, Front	1
9	B-6221-10	Stand	1
10	B-6223-10	Handle, Cart	1
11	B-6288-10	Lock Bar	1
12	20M0832P	1/4" x 2" RD HD Mach. Screw	4
13	20M1016P	5/16" x 1" RD HD Mach. Screw	10
14	2M1012P	5/16"-18 x 3/4" Hex Bolt	4
15	30M0800P	1/4"-20 Reg Hex Nut	4
16	30M1000P	5/16"-18 Reg Hex Nut	10
17	40M0800P	1/4" Med Lock Washer	4
18	40M1000P	5/16" Med Lock Washer	10
19	45M0909P	1/4" SAE Flat Washer	4
20	45M1111P	5/16" SAE Flat Washer	10
21	B-1675P	3/8"-16 Hex Lock Nut	1
22	B-3861	Hitch Pin (1/2" Dia. x 2-1/2")	1
23	B-4305	Retaining Ring, 3/4" E-Type	2
24	B-4786	5/16"-18 Nylon Lock Nut	4
25	B-5606	3/4" Mach. Bushing	4
26	B-5931	Clevis Pin, 5/16" Dia. x 3-1/2"	1
27	B-6298	Hex Bolt, 3/8" x 3-3/4" Full Thr.	1
28	B-6299	3/8"-16 Keps Nut	2
29	B-6300	Latch Spring	1
30	B-983	Hairpin Cotter, .08	1
*31	D-146P	Hair Pin Cotter 1/8"	1
32	B-4421	Spacers	2
33	B-5482	Decal-Caution	1

To Order Parts:  
 Brinly-Hardy Company  
 P.O. Box 18  
 Jeffersonville, IN. 47131-0018  
 877-728-8224

Visit us on the web:  
[www.brinly.com](http://www.brinly.com)



\*Spacers found in Z-1435-1D Sub Bag

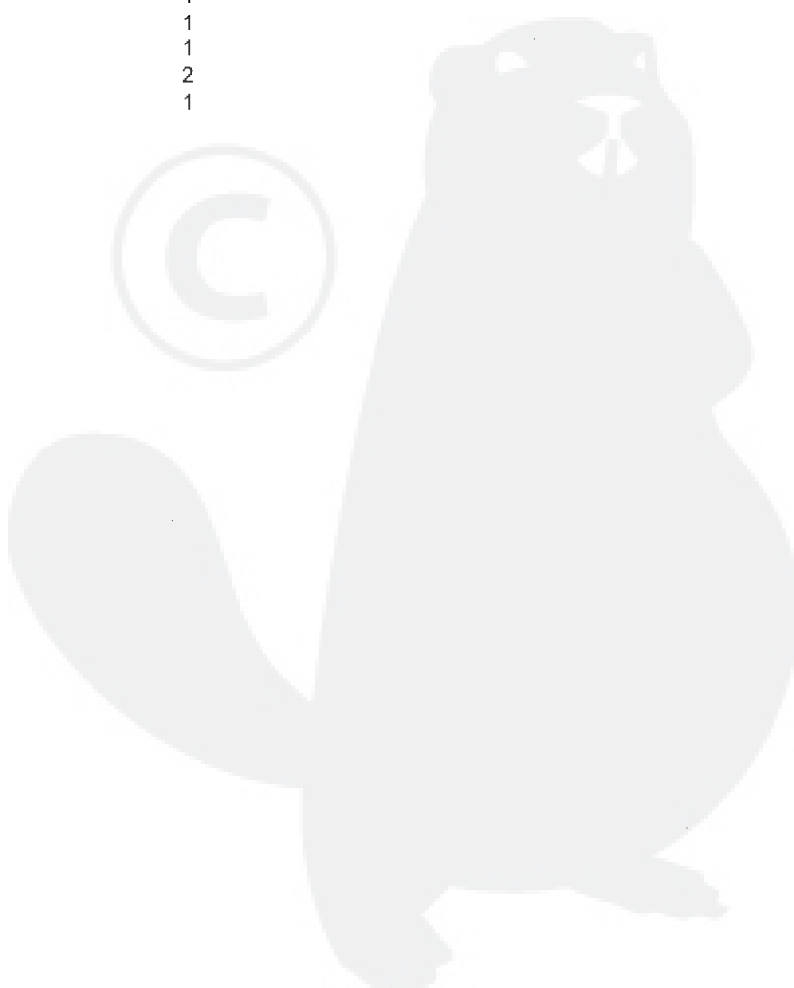

EXPLODED REFERENCE

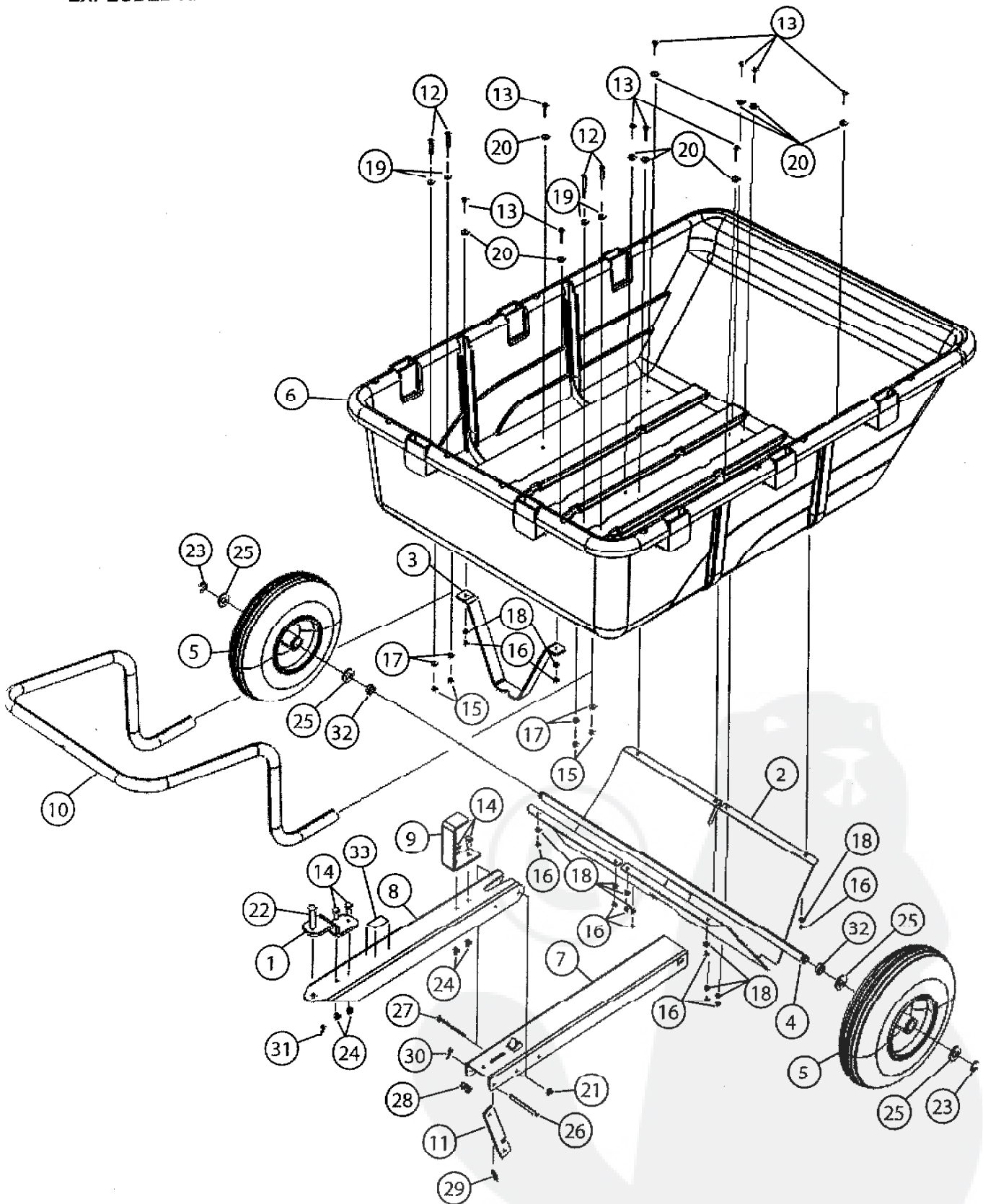

## ASSEMBLY

Figure 1.

### 1. Install Axle Support

- Position the Axle Support(2) slotted holes over the bed.

Secure Axle Support (2) with Machine Screw(13) and Washer(20) and Lock Washer(18) and Hex Nut(16) as shown. Assemble finger tight until all 8 screws are installed.

- Tighten Nuts.

Hardware used:  
 (13) 5/16" x 1" RD HD Mach. Screw  
 (16) 5/16"-18 Reg Hex Nut  
 (18) 5/16" Med Lock Washer  
 (20) 5/16" SAE Flat Washer

Figure 1.

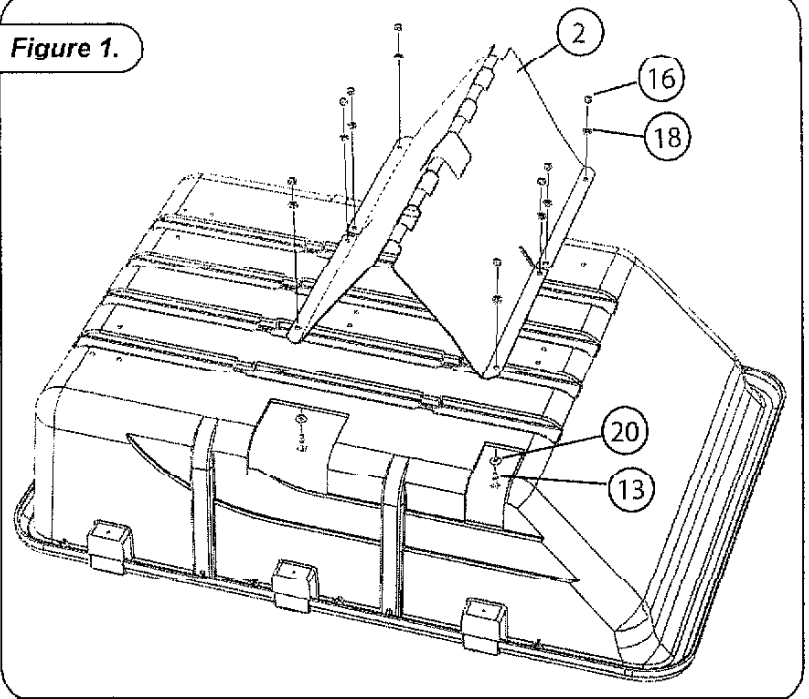

Figure 2.

### Install Lock Bracket & Handle

- Position Handle(10) as shown and secure with Screw(12) and Washer(19) and Lock Washer(17) and Hex Nut(15).
- Position Lock Bracket(3) as shown and secure Machine Screw(13) and Washer(20) with Lock Washer(18) and Hex Nut(16).

Hardware used:  
 (12) 1/4" x 2" RD HD Mach. Screw  
 (13) 5/16" x 1" RD HD Mach. Screw  
 (15) 1/4"-20 Reg Hex Nut  
 (16) 5/16"-18 Reg Hex Nut  
 (17) 1/4" Med Lock Washer  
 (18) 5/16" Med Lock Washer  
 (19) 1/4" SAF Flat Washer  
 (20) 5/16" SAE Flat Washer

Figure 2.

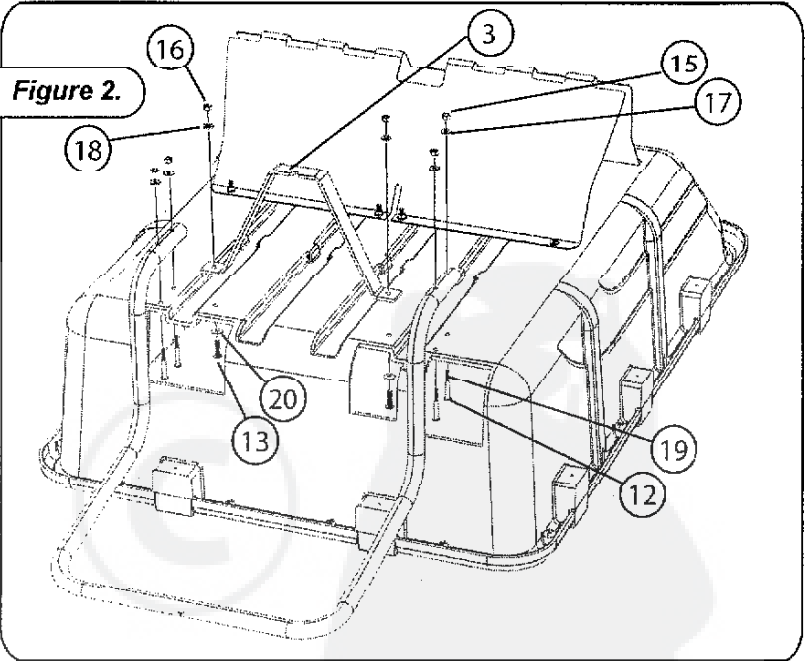

Figure 3A.

### Assemble Dump Latch

- Place Front Towbar (8) inside Rear Towbar (7) and align holes. The Dump Latch(11) is installed in the Front Towbar(8) and Rear Towbar (7) as shown in Figure 3A with the Notch facing the Tongue. Install the Keps Nuts(28) on the Hex Bolt(27) so that the Dump Latch is centered. Tighten the Keps Nuts(28) securely. Install the Lock Nut(21) so that the Hex Bolt(27) remains free to pivot.

Hardware used:  
 (21) 3/8"-16 Hex Lock Nut  
 (27) Hex Bolt, 3/8" x 3-3/4" Full Thr.  
 (28) 3/8"-16 Keps Nut

Figure 3A.

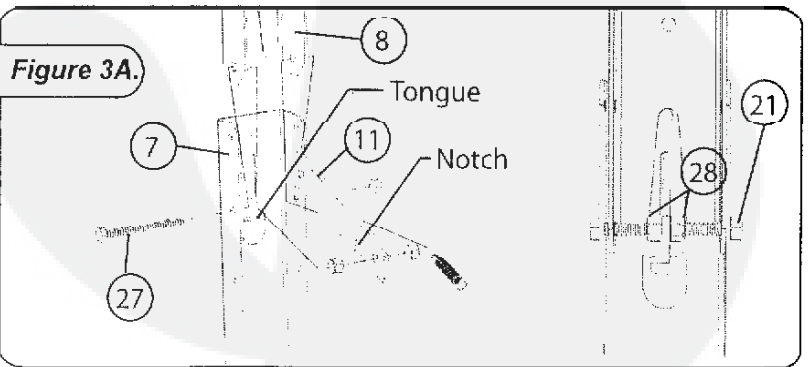

## ASSEMBLY

Figure 3B

- Hook one end of the Spring(29) to Rear Bar(7) hole and stretch the Spring(29) to position in the Dump Latch(11) hole.

Hardware used:  
(29) Latch Spring

Figure 3B.

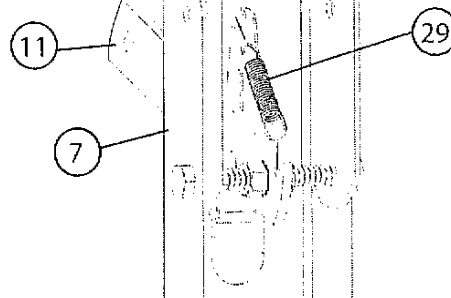

Figure 4.

### Assemble Stand & Clevis

- Install the Front Towbar(8) with Clevis Pin(26) and Cotter(30).
- Install Stand(9) as shown with Hex Bolts(14) and secure with Lock Nuts(24).
- Install Clevis(1) as shown with Clevis Pin(22) and Cotter Pin(31). Install Hex Bolts(14) and Secure with Lock Nuts.

Hardware used:  
(14) 5/16"-18 x 3/4" Hex Bolt  
(22) Hitch Pin (1/2" x 2-1/2" But. HD)  
(24) 5/16"-18 Nut, Lock, Nylon  
(26) Clevis Pin, 5/16" Dia. x 3-1/2"  
(30) Hairpin Cotter, .08  
(31) Hair Pin Cotter 1/8"

Figure 4.

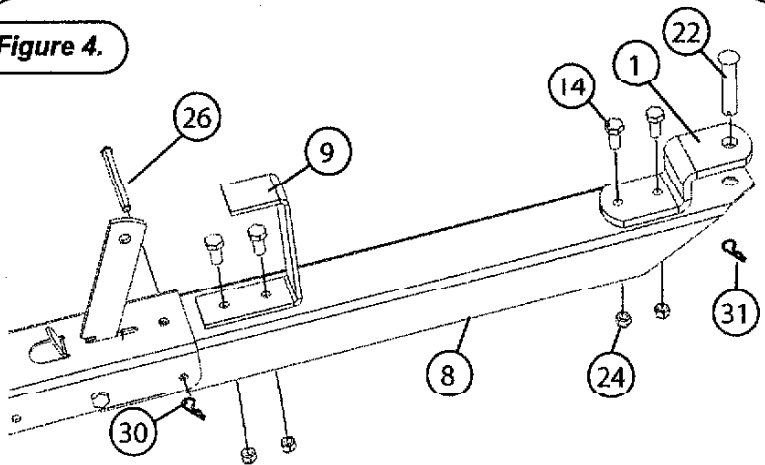

Figure 5.

### Install Towbar and Wheels

- Install Towbar Assembly and Axle(4) as shown. (A light coating of grease or oil will aid in inserting the Axle(4) through the Axle Support(2).)
- To assemble wheels follow the order of parts. First place Spacer(32) onto Axle(4) then followed by Bushing(25). Next is the Wheel then Bushing(25) finally place Retaining Ring(23), see note about installing Retaining Ring.

Hardware used:  
(25) 3/4" Mach. Bushing  
(32) Spacer  
(23) Retaining Ring

**NOTE:** USE PLIERS TO SNAP RETAINING RING(23) INTO GROOVE ON AXLE(4).

Figure 5.

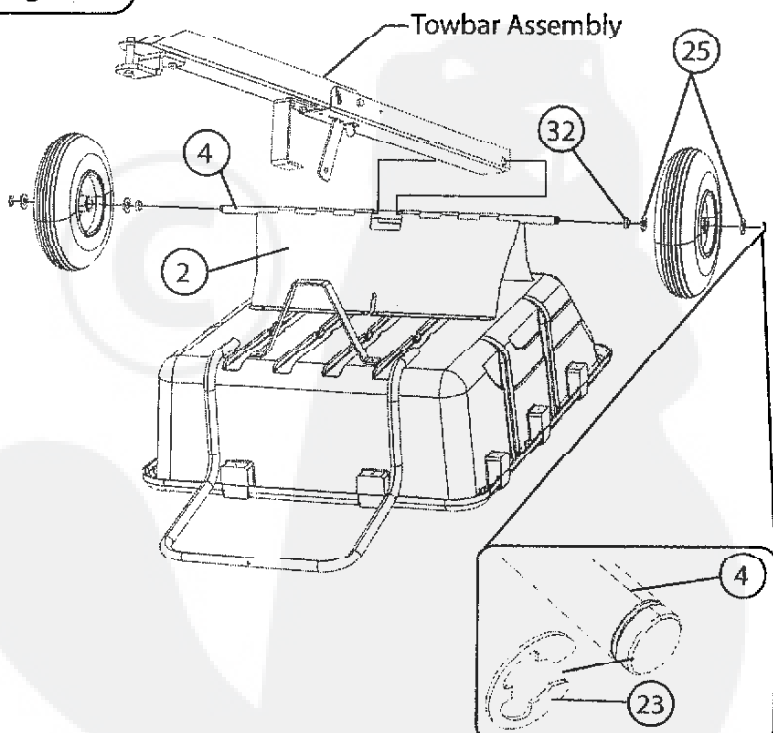



## **MAINTENANCE**

---

The key to years of trouble-free service is to keep your Cart clean and dry.

Unauthorized modifications to the cart may impair its function and safety.

Occasionally check all moving parts for free movement and, if necessary, lubricate with oil.

Should rust develop, sand lightly and then paint area with enamel.



## **OPERATION**

---

Avoid over filling Cart, it can cause tractor to lose traction and skid. The tractor and operator combined weight **MUST BE** more than loaded cart weight for **PROPER** towing and braking.

Extremely heavy loads will be difficult to dump. Fill to capacity that is comfortable for you to dump.

When Backing up, carefully back **STRAIGHT** to avoid "jack-knifing", which can cause damage to your equipment.



## **IMPORTANT**

---

Check tire pressure. Inflate to 30 P.S.I.



## **SAFETY TIPS**

---

Avoid tipping and skidding:

Weight of tractor and operator **MUST BE MORE** than weight of cart and load.

Use correct number of weights on tractor. If additional weight is required, add this weight at or forward of the rear wheels. Additional weight rearward of rear wheels causes a negative affect on vehicle steering.

A safe load on dry, level ground may cause the tractor to lose traction and skid on slippery or sloped ground.

**DO NOT** use cart near edges of ditch or bank or other steep angle.

Avoid holes, rocks and roots.

Slow down before you turn

**DO NOT** make sharp turns that cause tractor tires to rub cart drawbar.

**DO NOT** tow cart with box raised.



## **KEEP RIDERS OFF CART**

---

Keep riders out of cart.

Riders in cart are subject to injury, such as being struck by objects and being thrown off the cart during sudden starts, stops and turns.

Riders obstruct the operator's view, resulting in the cart being used in an unsafe manner.



Caring for the quality of your lawn  
with the products from  
**Brinly-Hardy Company**

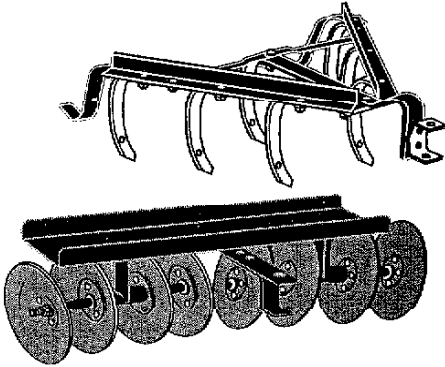

Brinly's garden tractor items offer the largest selection to turn your garden tractor into a year-round tool. We have box scrapers, blades, cultivators, disk harrows, and even a plow! Remember that a sleeve hitch is required to hook up these items to your garden tractor.

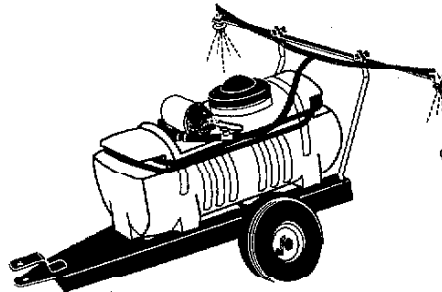

Brinly sprayers are designed to be easy to use, extremely accurate, and long lasting. Our in-line mounted tank design means that even the biggest tank is easy to maneuver and can fit through a garden gate. Each unit comes with a tractor-mounted on/off control.

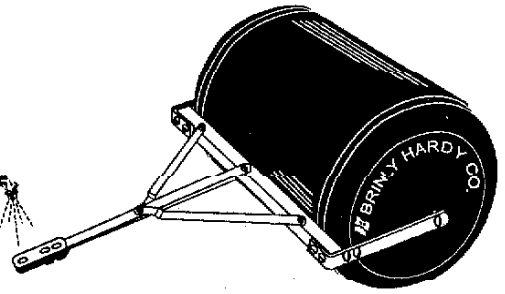

No more rust or dents with these poly lawn rollers. These units are much easier to deal with than the steel versions. They have rounded end caps that won't tear or gouge the lawn when turning. Erase the harmful effects of front heaving and moles, or pack down newly sown seed or sod.

**Limited Warranty**

Brinly-Hardy Company warrants only to the original retail purchaser that this product will remain free of defects in workmanship and materials under normal use and service for a period of two (2) years (NOTE: ninety (90) days for commercial or rental use) commencing with the date of purchase.

Any parts found to be defective within the warranty period will be replaced, with proof of date of purchase, at Brinly-Hardy Company's expense. Our obligation under this warranty is expressly limited to replacement or repair, at our option of parts, which are defective in material or workmanship within thirty (30) days of receipt of the parts. This warranty does not apply to damage caused by unreasonable use, including failure to provide necessary maintenance, nor does it apply to any transportation or labor charges.

WE MAKE NO OTHER EXPRESS WARRANTY NOR IS ANYONE AUTHORIZED TO MAKE ANY ON OUR BEHALF. ANY IMPLIED OR STATUTORY WARRANTIES, INCLUDING ANY WARRANTY OF MERCHANTABILITY OR FITNESS FOR A PARTICULAR PURPOSE, ARE LIMITED TO THE DURATION OF THIS WRITTEN WARRANTY. WE SHALL NOT BE LIABLE FOR CONSEQUENTIAL OR INCIDENTAL DAMAGES OF ANY KIND.

MADE IN THE U.S.A.  
BRINLY-HARDY COMPANY TOLL-FREE 1-877-728-8224

Register Online at: [www.brinly.com](http://www.brinly.com)

**Quality Insurance**

Dear Customer,  
We are very proud of our quality and endeavor to produce each product to meet high standards. Should your purchase not meet your expectations, we have a Quality Insurance Policy.

If you purchase a product and a part is missing or defective, please inform us of the problem on the "Comments" section of the Warranty Registration Card in this manual or online, or feel free to contact us toll free at 1-877-728-8224. PLEASE DO NOT RETURN THE PRODUCT TO THE STORE!

We will make every effort to ship a new replacement part to you within 24 hours at no charge.

Thank you,

  
Jane Hardy  
President,  
Brinly-Hardy Company

**WARRANTY REGISTRATION CARD**

To register your new product for warranty, please complete and return this card

Name: \_\_\_\_\_  
 Address: \_\_\_\_\_  
 City: \_\_\_\_\_ State: \_\_\_\_\_ Zip: \_\_\_\_\_  
 Phone: \_\_\_\_\_  
 Product Purchased: \_\_\_\_\_ Model#: \_\_\_\_\_  
 Packing# (on carton): \_\_\_\_\_  
 Where purchased: \_\_\_\_\_ Date: \_\_\_\_\_  
 Type of Tractor Owned: Make: \_\_\_\_\_  
 Model: \_\_\_\_\_  
 HP: \_\_\_\_\_  
 Size of Lawn: \_\_\_ 1/4-1/2 acre \_\_\_ 1/2-1 acre \_\_\_ 1-5 acre \_\_\_ 5+  
 Do you garden? \_\_\_\_\_ Use a tractor? \_\_\_\_\_ Tiller? \_\_\_\_\_  
 Your Occupation? \_\_\_\_\_  
 Your Email Address? \_\_\_\_\_