

**SHINDAIWA OWNER'S/
OPERATOR'S MANUAL**

**MULTIPURPOSE
POWERBROOM TOOL**



WARNING!

Always wear eye and ear protection when operating this machine!



WARNING!

To minimize the risk of injury to yourself and others, read this manual and familiarize yourself with its contents.

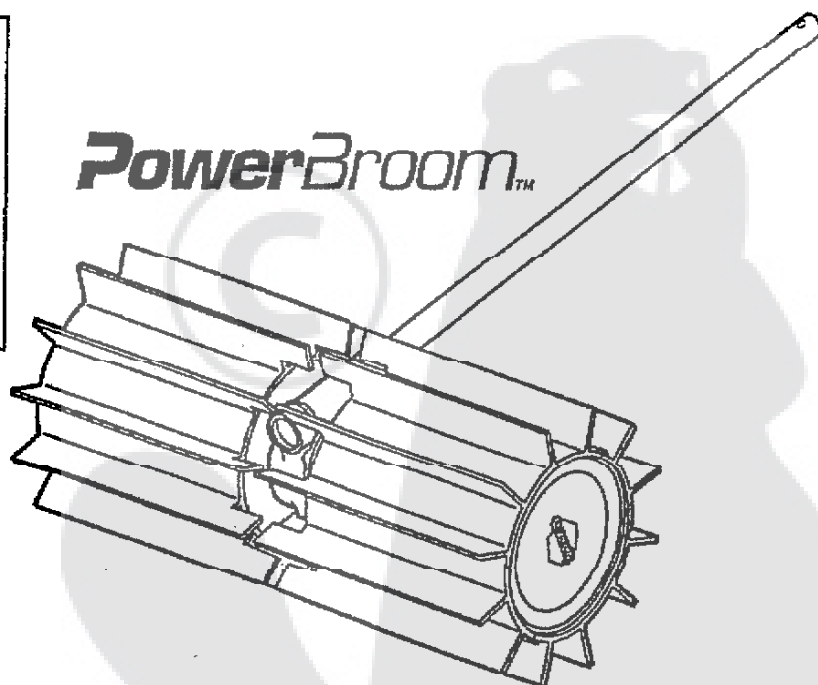

PowerBroom™

shindaiwa

Introduction

The Shindaiwa Multipurpose PowerBroom™ Tool has been designed and built to deliver superior performance and reliability without compromise to quality, comfort, safety or durability.

As an owner/operator, you'll soon discover for yourself why Shindaiwa is simply in a class by itself!

IMPORTANT!

The information contained in these instructions describes machines available at the time of publication.

Shindaiwa Inc. reserves the right to make changes to products without prior notice, and without obligation to make alterations to machines previously manufactured.

Contents

	PAGE
Attention Statements.....	4
Safety Labels	5
Operating Precautions	6
General Safety Instructions	8
Product Description	9
Specifications	9
Install the Handle	10
Sweeper Assembly	11
Tool Installation	12
Checking Unit Condition	13
Strap & Hanger and Debris Shield .	14
Operation	15
Maintenance	17
Troubleshooting Guide	19
Illustrated Parts List	20

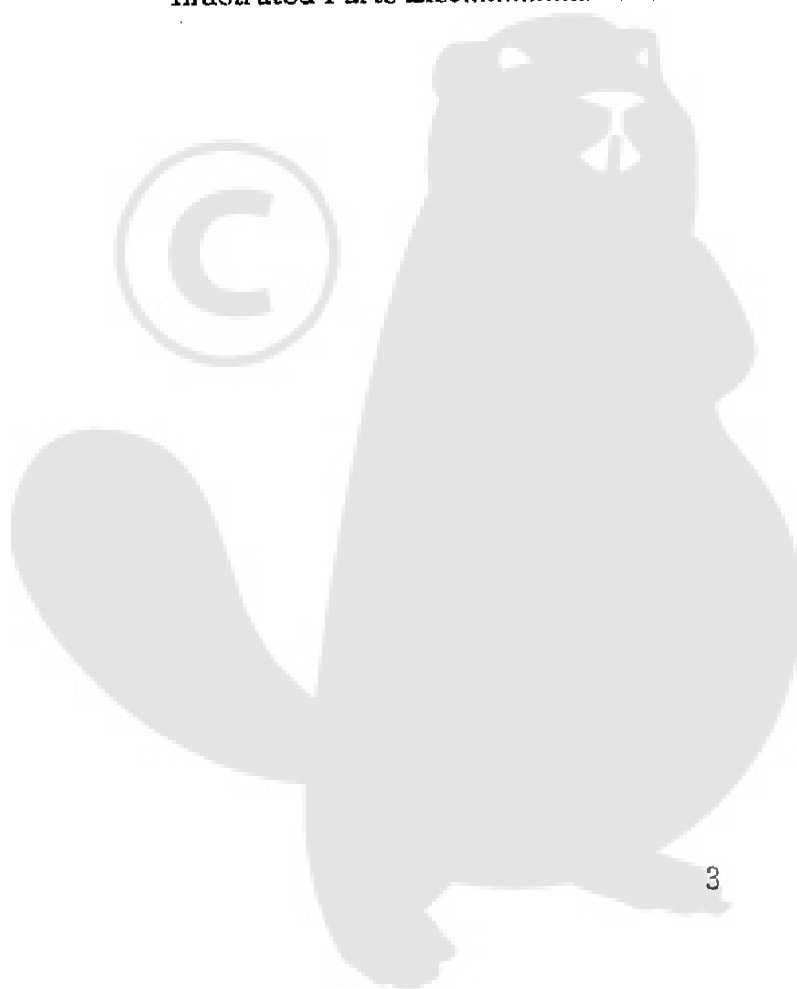

Attention Statements

Throughout this manual are special "attention statements".



WARNING!

A statement preceded by the triangular attention symbol and the word "WARNING" contains information that should be acted upon to prevent serious bodily injury.

CAUTION!

A statement preceded by the word "CAUTION" contains information that should be acted upon to prevent mechanical damage.

IMPORTANT!

A statement preceded by the word "IMPORTANT" is one that possesses special significance.

NOTE:

A statement preceded by the word "NOTE" contains information that is handy to know and may make your job easier.



READ AND FOLLOW THIS MANUAL. FAILURE TO DO SO COULD RESULT IN SERIOUS INJURY.



WEAR EYE AND HEARING PROTECTION AT ALL TIMES DURING THE OPERATION OF THIS UNIT.



BEWARE OF THROWN OBJECTS. KEEP BYSTANDERS AT LEAST 50 FEET (15 M) AWAY DURING OPERATION.



DO NOT OPERATE THIS TOOL IF YOU ARE TIRED, ILL OR UNDER THE INFLUENCE OF ALCOHOL, DRUGS, OR MEDICATION.

IMPORTANT!

The operational procedures described in this manual are intended to help you get the most from your machine as well as to protect you and others from harm. These procedures are guidelines for safe operation under most conditions, and are not intended to replace any safety rules and/or laws that may be in force in your area. If you have questions regarding your 230-series power tool, or if you do not understand something in this manual, your Shindaiwa dealer will be glad to assist you. You may also contact Shindaiwa, Inc. at the address printed on the back of this manual.

Safety Labels

IMPORTANT!

Safety and Operation Information Labels: Make sure all information labels are undamaged and readable. Immediately replace damaged or missing information labels. New labels are available from your local authorized Shindaiwa dealer.

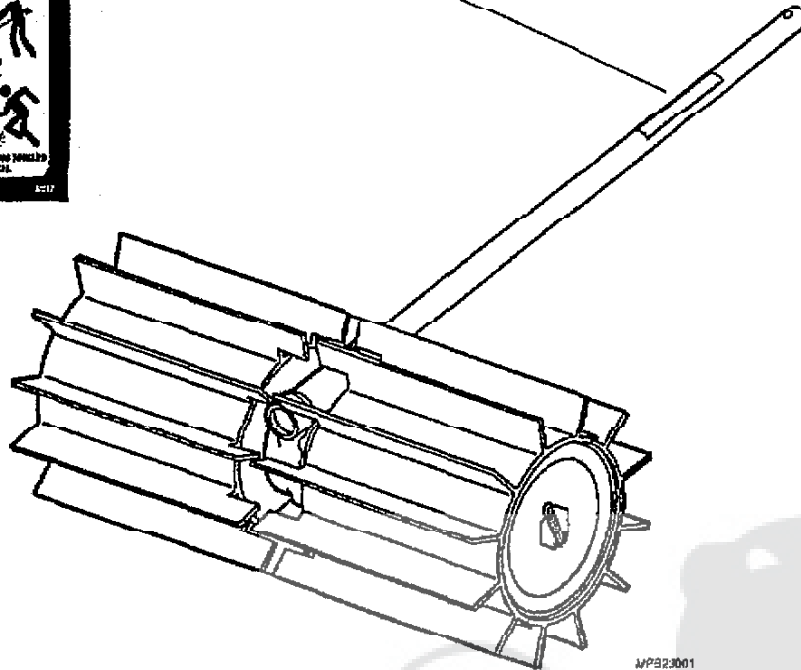

Figure 1

WPB23001

Operating Precautions



WARNING!

- This Shindaiwa PowerBroom tool is specifically designed for use on the Shindaiwa Multipurpose Tool Carrier. Installation and/or use on any other model, brand or type of power tool is not approved by Shindaiwa. Attempts to use on non-approved models can damage the equipment and cause accidents, serious injury or death.
- Always make sure the Multipurpose PowerBroom Tool is properly installed and firmly tightened before operation.
- Make sure there are no missing or loose fasteners, and that the stop switch and throttle controls are working properly.
- Make sure there is always good ventilation when operating this machine. Fumes from engine exhaust can cause serious injury or death. **Never run the engine indoors!**
- Sweeper belts may move when starting engine. Place sweeper belts on a smooth level surface when starting.
- Always stop the engine immediately and check for damage if you strike a foreign object or if the machine becomes tangled. Do not operate with broken or damaged equipment.
- Stop the machine immediately if it suddenly begins to vibrate or shake. Inspect for broken, missing or improperly installed parts or attachments.
- Never transport the machine or set it down with the engine running. An engine that's running could be accidentally accelerated causing the drum assemblies to rotate.

CAUTION!

Always keep the unit as clean as practical. Keep it free of loose vegetation, mud, etc.

The Properly Equipped Operator

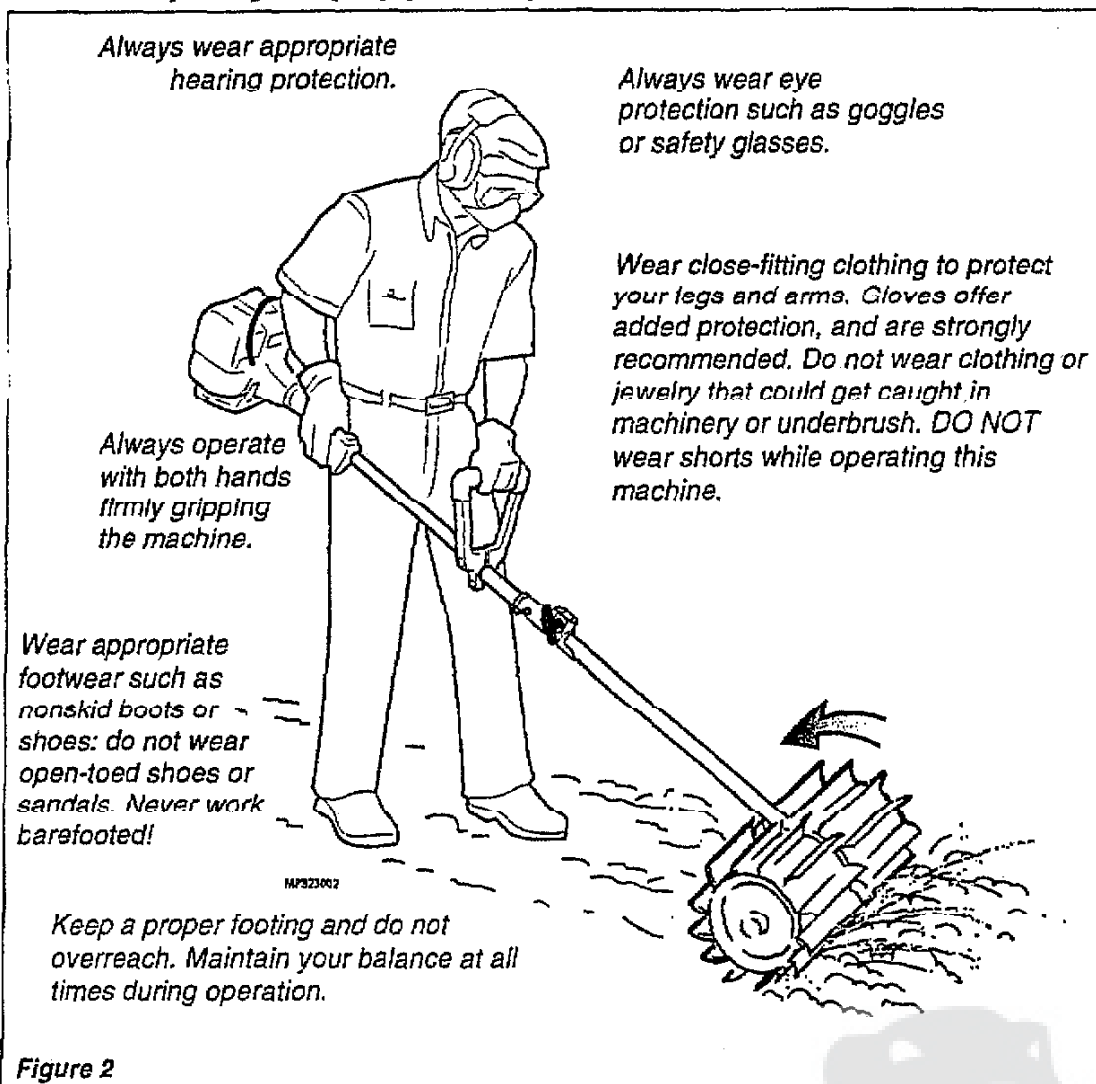

Work Safely: Be Aware of the Working Environment

- Be careful when operating on a slope or on slippery terrain, especially during rainy weather.
- If the drum assemblies jam, switch the engine OFF and inspect the drums, axles and gearcase for damage.
- Never operate the PowerBroom around objects that could tangle in the drums and cause loss of control.
- Maintain a low working angle and avoid steep angles of operation. A steep working angle risks loss of control of the machine.
- Transport the machine with the engine OFF.

General Safety Instructions



WARNING!

Never operate power equipment of any kind if you are tired or if you are under the influence of alcohol, drugs, or any other substance that could affect your ability or judgement.



WARNING! Minimize the Risk of Fire

Never smoke or light fires near the trimmer.

Always stop the engine and allow it to cool before refueling. Avoid overfilling and wipe off any fuel that may have spilled.

Always move the unit to a place well away from a fuel storage area or other readily flammable materials before starting the engine. Use caution when handling fuel. Move the power tool at least 10 feet (3 meters) from the fueling point before starting the engine.

Never place flammable material close to the engine muffler.

Never run the engine without the spark arrester screen in place. Do not operate the machine with the muffler removed.



WARNING! Use Good Judgment

Always wear eye protection to shield against thrown objects.

Always protect yourself from hazards such as thorny brush and flying debris by wearing gloves and close fitting clothing that covers arms and legs. Never wear shorts. Don't wear loose clothing or items such as jewelry that could get caught in machinery or underbrush. Secure long hair so it is above shoulder level.

Always clear your work area of trash or hidden debris that could be thrown back at you or toward a bystander.

Always stop the machine immediately if it suddenly begins to vibrate or shake. Inspect for broken, missing or improperly installed parts or attachments.

Always hold the machine firmly with both hands when sweeping, and maintain control at all times.

Always keep the handles clean.

Always disconnect the spark plug wire before performing any maintenance work.

Product Description and Specifications

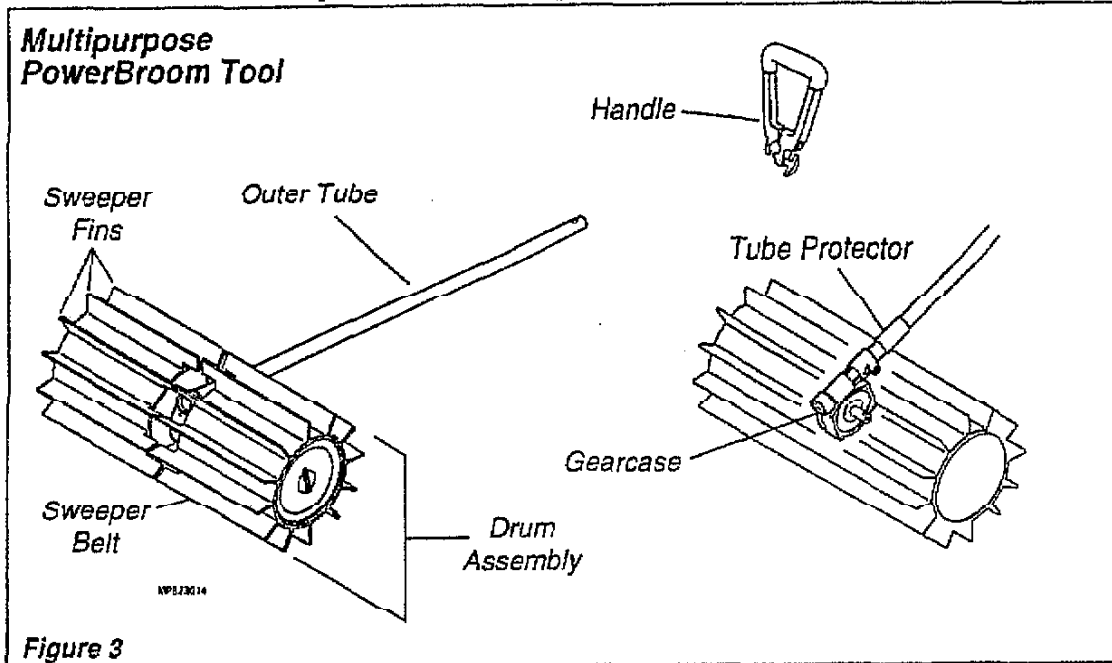

Figure 3

Using the accompanying illustration as a guide, familiarize yourself with your machine and its various components. Understanding your machine helps ensure top performance, long service life and safer operation. See Figure 3.



WARNING!

Do not make unauthorized modifications or alterations to any of these units or their components.

Multipurpose PowerBroom Tool Specifications*

Multipurpose PowerBroom Tool (w/drum assemblies)	11.4 lbs. (5.2 kg)
Gearcase Lubrication	Mobil SCH 634 synthetic gear lubricant
Gear Reduction	40:1

*Specifications are subject to change without notice.

Prior to Assembly

Before assembling, make sure you have all the components required for a complete unit:

- Outer Tube/Mainshaft Assembly with Gearcase and Shaft Protector
- (2) Drum Assemblies (2) Axles (1) Handle Assembly
- Kit containing hardware, this owner's/operator's manual and a 5 mm hex key.

Carefully inspect all components for damage.

IMPORTANT!

The terms "left", "left-hand", and "LH"; "right", "right-hand", and "RH"; "front" and "rear" refer to directions as viewed by the operator during normal operation.

Install the Handle

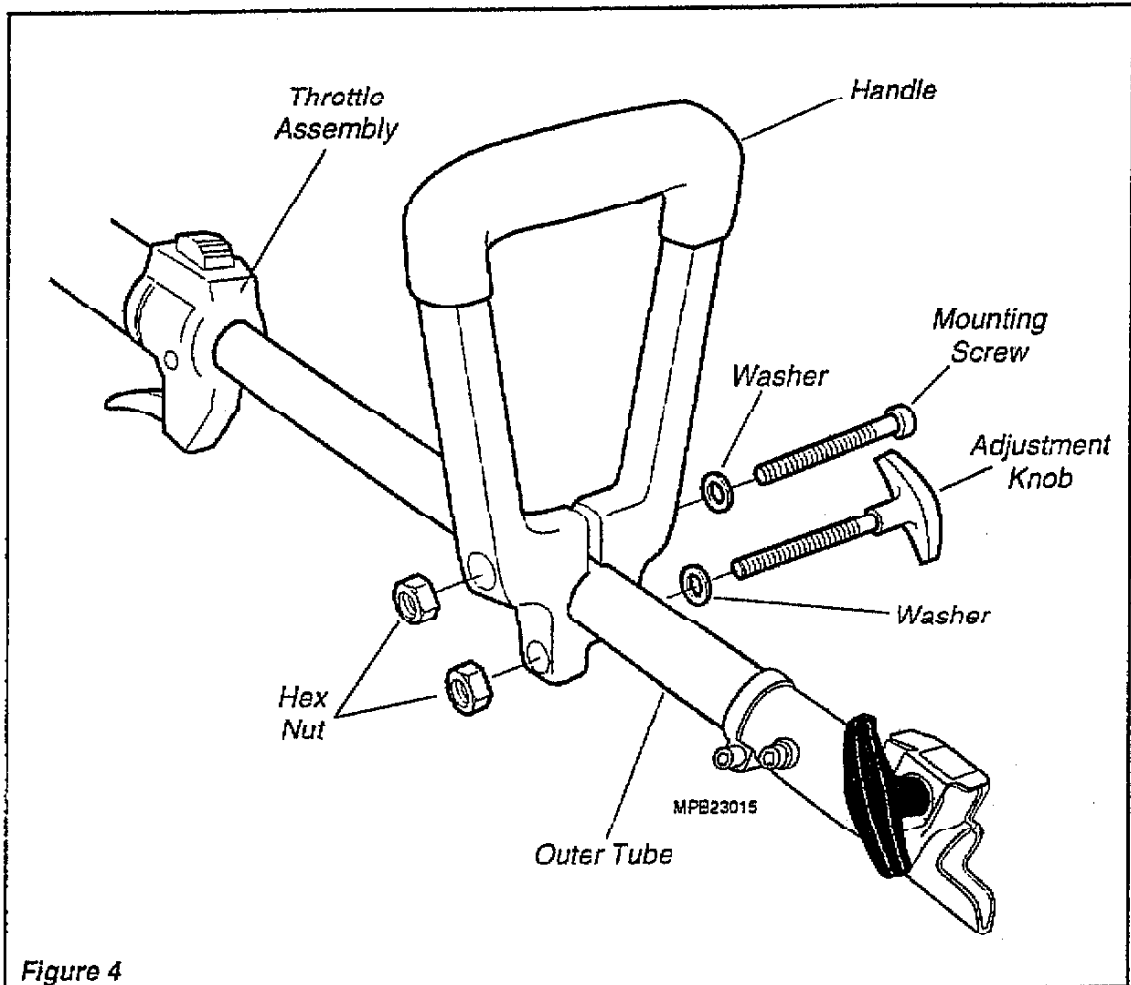

Figure 4

If You Wish to Use the Adjustable Handle Assembly: Connect the Handle to the Outer Tube

1. Remove the M230/M231 loop handle.
2. Remove both screws from the adjustable handle assembly.
3. While spreading the handle at the mounting hole, position the handle on the outer tube as shown.
4. Reinstall the two mounting screws in the handle, but do not tighten them at this time.

IMPORTANT!

One side of the handle is recessed to receive the two hex nuts.

5. Locate the handle at the best position for operator comfort (usually about 10 inches ahead of the throttle lever), and secure it by tightening the adjustment knob at the handle base. See Figure 4.

Sweeper Assembly

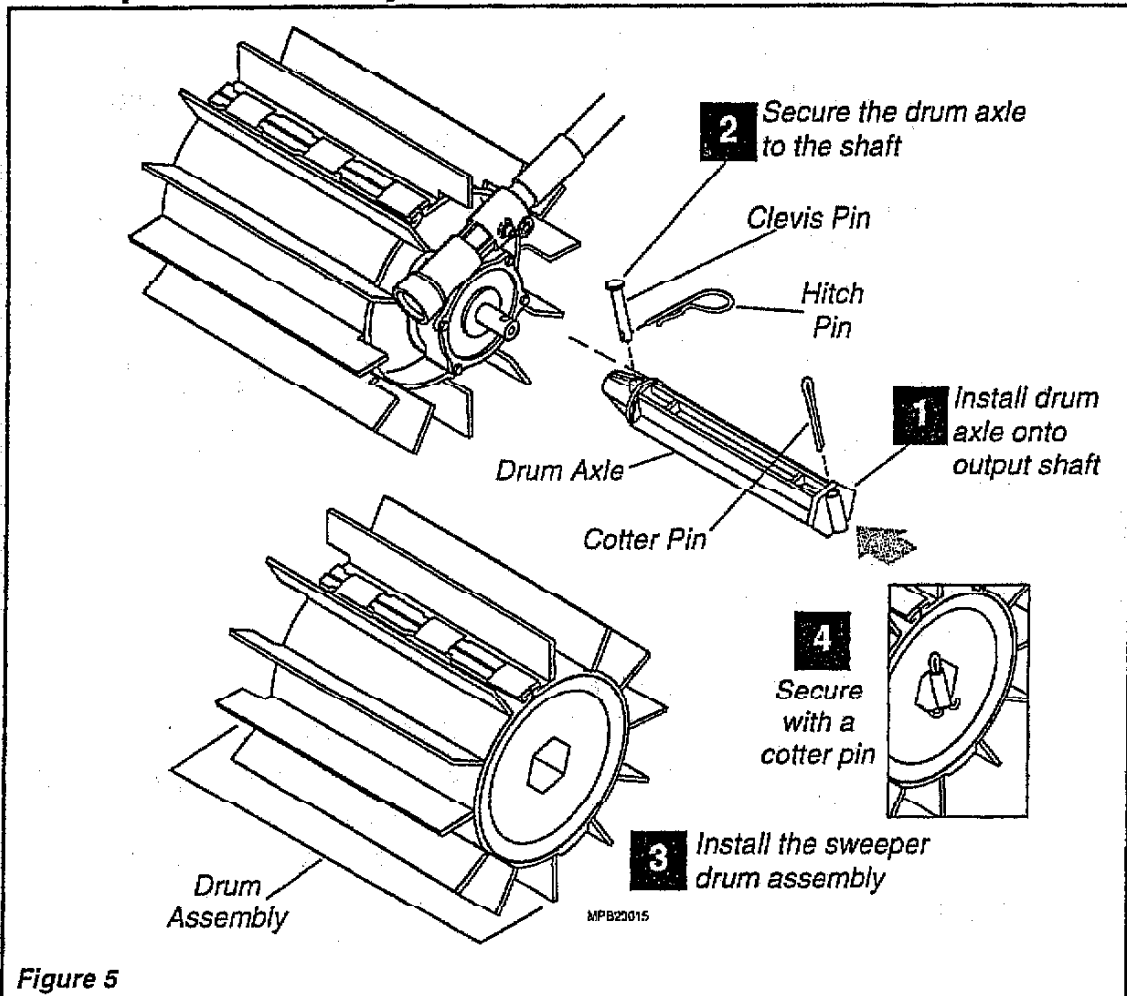

Figure 5

1. Push one of the drum axles onto either of the two gearcase output shafts. If necessary, rotate the drum axle until the clevis pin hole in the axle aligns with the matching hole in the gearcase output shaft.
2. Use a clevis pin and hitch pin to secure the drum axle to the shaft.
3. Slide the recessed end of a sweeper drum assembly over the installed axle, and then push the drum down the axle until the cotter pin hole in the axle extends above the drum surface.
4. Use a cotter pin to secure the drum assembly on the axle (see inset). The cotter pin is designed to fit tightly against the outboard end of the drum, so you may need to compress the drum face slightly during installation. spread the ends of the cotter pin to secure.
5. Repeat Steps 1-4 to install the remaining axle and drum assembly.

The M230/M231 PowerBroom Tool should now be completely assembled.

CAUTION!

The two drum assemblies are identical, but each drum must be installed with its recessed end facing toward the gearcase.

Installing a Tool Attachment

1. Place the M230/M231 Multipurpose Tool Carrier and the Tool Assembly on a clean, flat surface so that both assemblies fit end to end. The M230/M231 assembly should be facing up, and the tool assembly should be positioned with the locking hole in the tube end facing up.

CAUTION!

Keep the open ends of the tubes clean and free of debris!

2. Slip off the protective cover from the end of the tool assembly and loosen the coupler screw knob.
3. Insert the tool assembly into the coupler, with the tool decal facing up, until the line of the decal is flush with the end of the coupler. Twist the tool back and forth until you are sure the coupler latch snaps in place. See Figure 6.

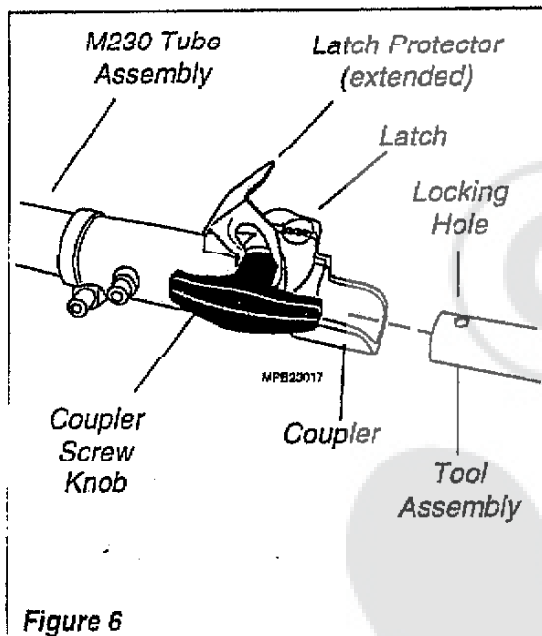

4. When the two tube halves are locked together, press down on the spring-loaded latch protector and tighten the coupler screw. See Figure 7.

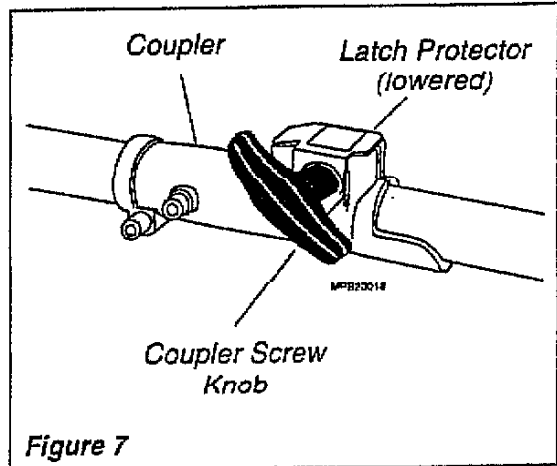

Disassembling The Sections

1. With the Multipurpose PowerBoom on a clean, flat surface, loosen the coupler screw. The spring-loaded coupler protector should pop up.
2. Depress the latch with your finger or thumb. This releases the coupler lock. See Figure 8.
3. Pull the tool assembly out of the coupler.

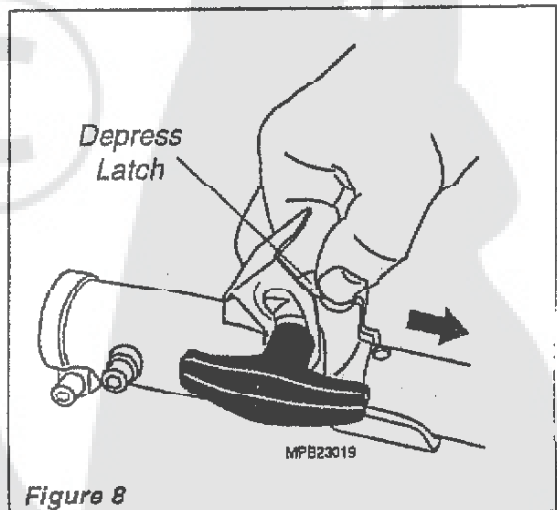

Checking Unit Condition

NEVER operate the unit with the protective devices (ignition switch, etc.) removed!

Use only authorized Shindaiwa parts and accessories with your Shindaiwa Multipurpose Tool. Do not make modifications to your machine without the written approval of Shindaiwa, Inc.

ALWAYS make sure the PowerBroom tool is properly installed and firmly tightened before operation.

NEVER use a cracked or warped PowerBroom drum or axle: replace it with a serviceable one.

ALWAYS stop the engine immediately and check for damage if you strike a foreign object or if the machine becomes tangled. Do not operate with broken or damaged equipment.

NEVER allow the engine to run at high RPM without a load. Doing so could damage the engine.

NEVER operate a machine with worn or damaged fasteners or attachment holders.

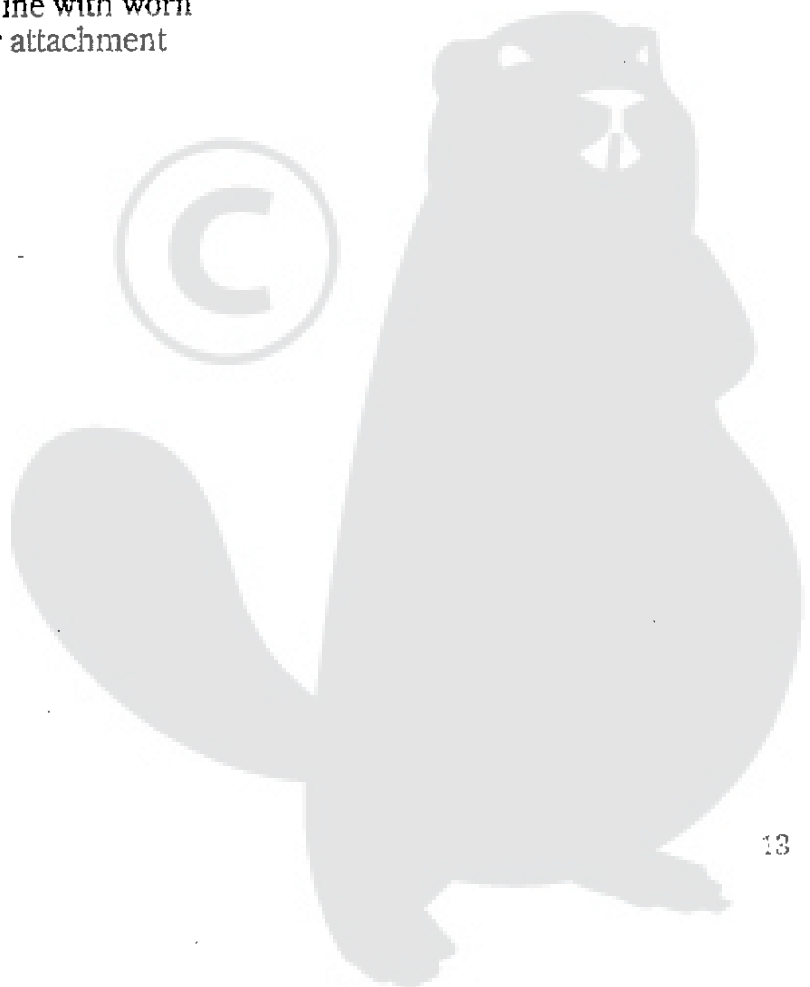

Strap and Hanger

p/n 22410-17201 and 60840-98020
(optional)

Although a strap and hanger is not required for use with a Shindaiwa M230/M231 PowerBroom Tool, it is recommended to reduce operator fatigue during extended periods of operation.

Make sure all hooks and adjusting devices are secure. Adjust the harness shoulder strap so the shoulder pad rests comfortably on the off-side shoulder. See Figure 9.

OPERATION

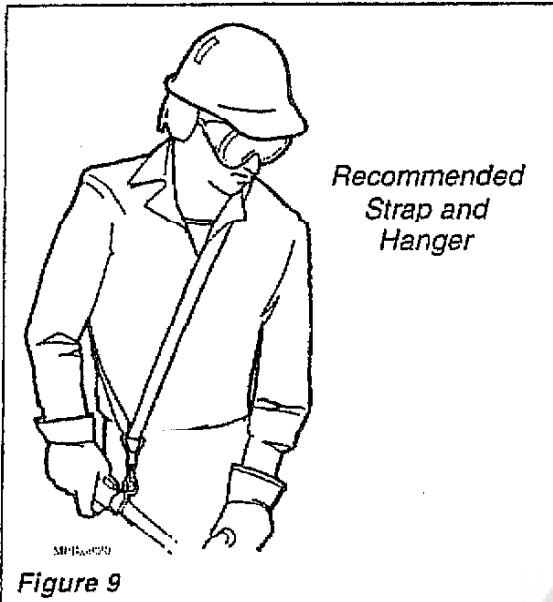

Debris Shield

p/n 99909-33021 (optional)

A plastic debris shield is available from your Shindaiwa dealer as a useful option to your PowerBroom. The shield helps prevent broadcasting debris when large volumes of material are forced over the top of the drum during operation. See Figure 10.

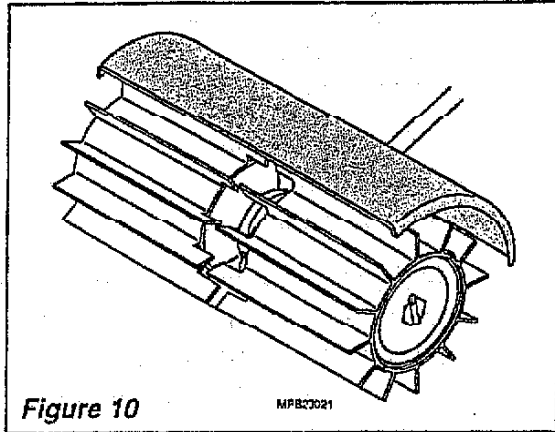

Operation

Starting and Fueling

For detailed instructions on general safety procedures, fueling, starting, and stopping the Shindaiwa Multipurpose Tool Carrier, refer to the appropriate Owner's Manual for your model machine.



WARNING!

KEEP CLEAR of drum assemblies during starting operations! The drums may rotate during startup.

Break-in and Operation

The PowerBroom works best when its rubber fins can quickly slide or "skim" over the surface being swept.

New or replacement sweeper belts tend to grip or drag on hard surfaces, and should be thoroughly broken in or "scuffed" before the broom is actually put to work.

Break-in is easily accomplished by operating the PowerBroom at full throttle for 3 to 5 minutes in loose gravel or similar abrasive material. Once broken in, a PowerBroom will effortlessly move an amazing variety of materials, ranging from snow or standing water to heavier objects such as gravel or wood chips.

Experience will help you understand the operating principles of the PowerBroom, but safe operation must be practiced from the start.



WARNING!

BURN DANGER! The gearcase will become very hot during normal operation.

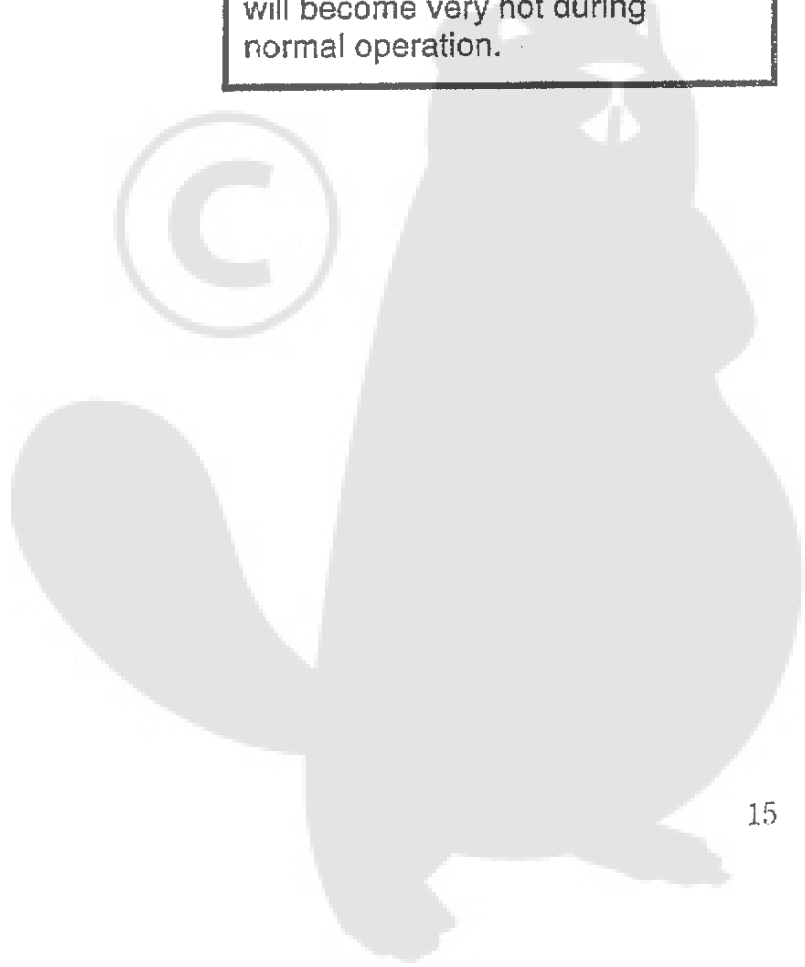

Operating Techniques

Operate the PowerBroom at or near full throttle with its sweeper fins resting on the work surface.

IMPORTANT!

It is both tiring and unnecessary to lift or hold the fins from the work surface during sweeping.

When sweeping narrow areas such as sidewalks, the PowerBroom can be used to throw material directly ahead of the operator. Clearing wider areas may require sweeping at an angle to create windrows to one side of the path being cleared.

Windrows of lighter materials often can be combined into one main row or pile for eventual pickup, while heavy or bulky material may need to be collected row-by-row. See Figure 11.

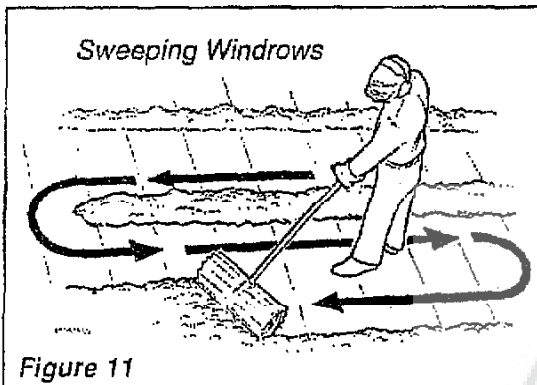

To pull debris from corners, reverse sweeper drum rotation by turning the powerhead over (throttle facing "up"). See Figures 12 and 13.



WARNING!

Reversing the PowerBroom will cause debris to be thrown back toward the operator. When reversing the PowerBroom, use lower throttle settings and be aware that thrown debris may also affect your footing!

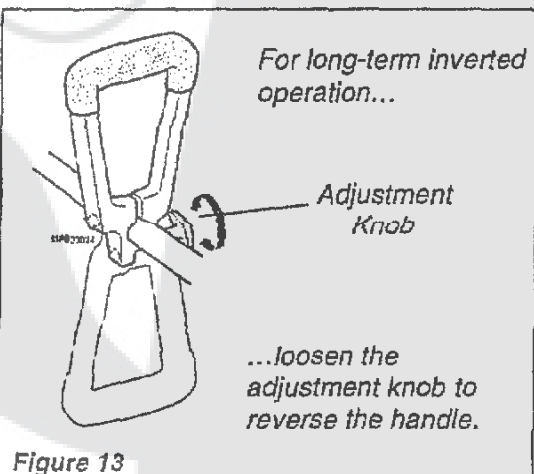
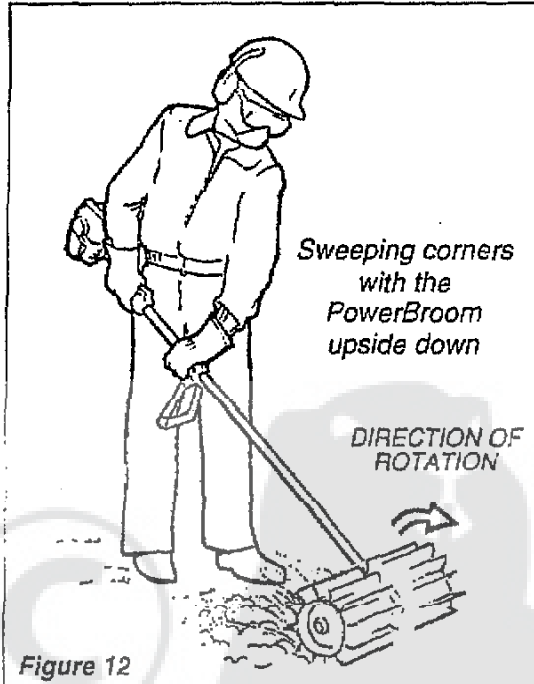

Maintenance



WARNING!

Before performing any maintenance, repair, or cleaning work on the unit, make sure the engine and attachment are completely stopped. Disconnect the spark plug wire before performing service or maintenance work.



WARNING!

Non-standard parts may not operate properly with your unit, may cause damage and could lead to personal injury.

IMPORTANT!

For detailed maintenance information about your Multipurpose Tool Carrier, consult the owner's manual that was provided with it. If it has been lost or misplaced, contact Shindaiwa for a replacement.

NOTE:

Using non-standard replacement parts could invalidate your Shindaiwa warranty.

Daily Engine Maintenance

Prior to each work day, perform the following:

- Carefully remove any accumulations of dirt or debris from the muffler and fuel tank. Dirt buildup in these areas can lead to engine overheating, fire, or premature wear.
- Check for loose or missing screws or components.
- Check the entire machine for leaking fuel or grease.
- Make sure that nuts, bolts, and screws (except carburetor adjusting screws) are tight.

50-hour Maintenance

Every 50 hours of operation (more frequently in dusty or dirty conditions):

- Remove and clean the cylinder cover and clean grass and dirt from the cylinder fins.
- Use a wire hook to extract the fuel filter from inside the fuel tank. Remove and replace the filter element. Before reinstalling the filter, inspect the condition of the fuel line. If damage or deterioration are noted, the unit should be removed from service until it can be inspected by a Shindaiwa-trained service technician. See Figure 14.

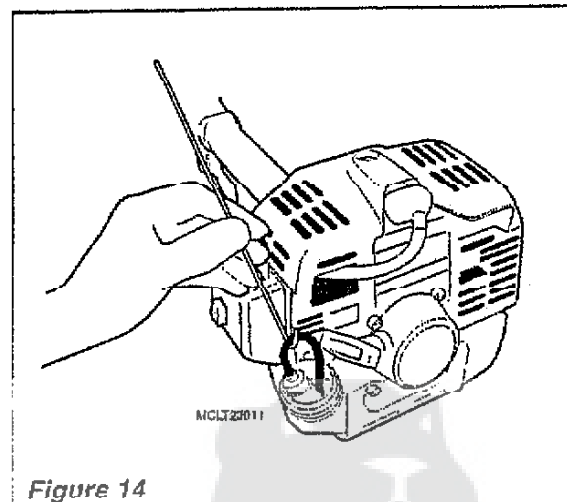

Figure 14

CAUTION!

Make sure you do not pierce the fuel line with the end of the hooked wire as the line can be damaged easily.

300-hour Maintenance

Gearcase Lubrication

The gearcase should be filled with 60 cc (2.0 fl.oz.) of Mobil SHC634 Synthetic Gear Oil. A maximum of 75-80 cc can be used, but never to exceed 80 cc. Operation with excessive oil level will result in high operating temperatures. **Do not overfill!**

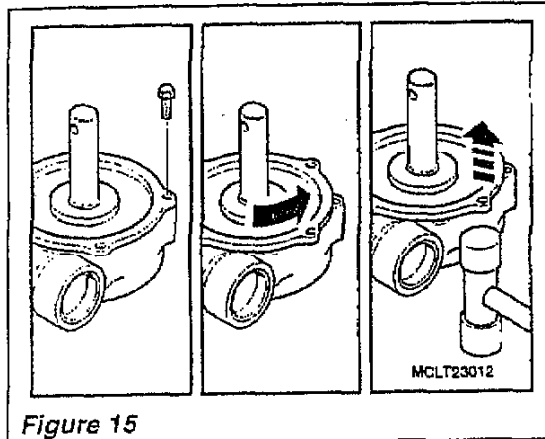

Figure 15

Replacing the gearcase oil



WARNING!

BURN DANGER! The gearcase will be extremely hot after use!

1. Disconnect spark plug wire at engine.
2. Remove the LH Drum and axle assembly (as viewed from the operating position). Wipe the sideplate clean and remove four screws (it is not necessary to remove the gearcase from the outer tube).
3. Turn gearcase side plate to break the seal and lift the plate from the gearcase. See Figure 15.
4. Turn the gearcase to the LH side and allow all used gearcase oil to drain into a small container.
5. Place the gearcase on the RH side and supported so the outer tube is parallel to the ground. Refill the gearcase with 60 cc (2.0 fl.oz.) of Mobil SHC634 Synthetic Gear Oil to the bottom of the chamfer on the output gear. The correct oil depth is 5/8" (15.5 mm). See Figure 16. **DO NOT OVERFILL!**
6. Inspect the sideplate for damage and clean off all remaining liquid gasket material with brake cleaner or acetone. Coat the outer sealing flange of the sideplate with Loctite Ultragrey Silicon Sealant or Threabond No. 1104 Liquid Gasket.
7. Replace the cover and install the four sideplate screws. Tighten securely.
8. Reinstall the drum and axle assembly per the sweeper assembly instructions. See page 11.

NOTE:

It may be necessary to use a heat gun to soften the sealer material.

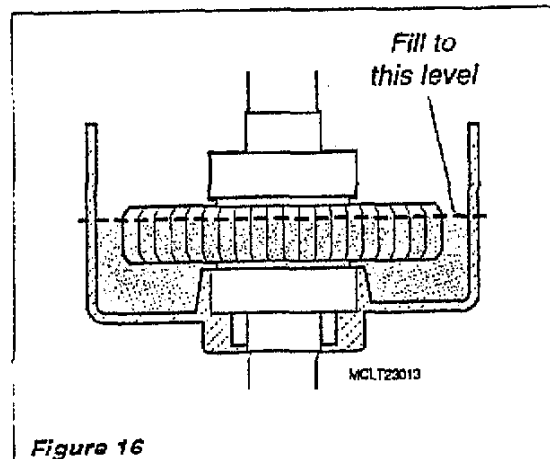
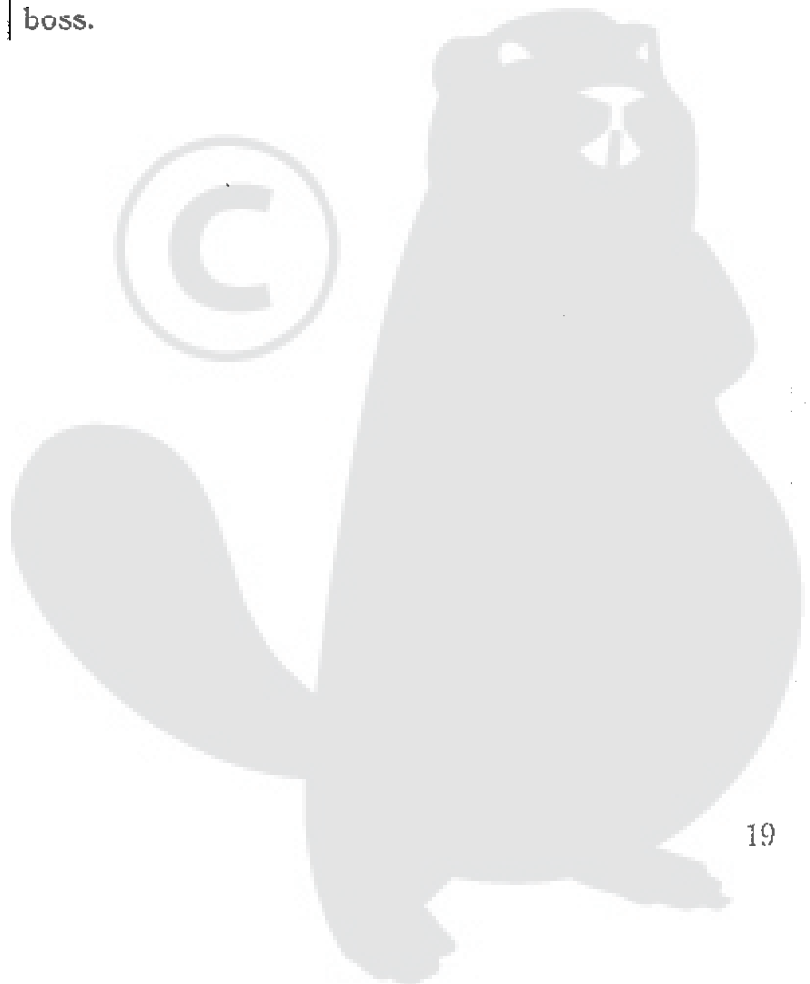
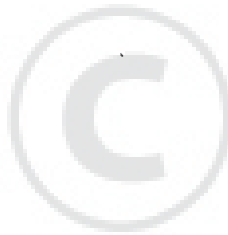

Figure 16

Troubleshooting Guide

ADDITIONAL PROBLEMS

Symptom	Possible Cause	Remedy
Excessive vibration.	Warped or damaged drums or belts.	Inspect and replace drum or belt as required.
	Loose gearcase.	Tighten gearcase securely.
	Bent main shaft/worn or damaged bushings.	Inspect and replace as necessary.
Drums will not rotate.	Shaft not installed in coupler or gearcase.	Inspect and reinstall as required.
	Broken shaft.	Consult with an authorized servicing dealer.
	Damaged gearcase.	Consult with an authorized servicing dealer.
Drums rotate at engine idle.	Engine idle too high.	Adjust engine idle speed to 2,750 RPM. (± 250)
	Broken clutch spring or worn clutch spring boss.	Replace clutch spring and shoes as required.



TROUBLESHOOTING

Illustrated Parts List

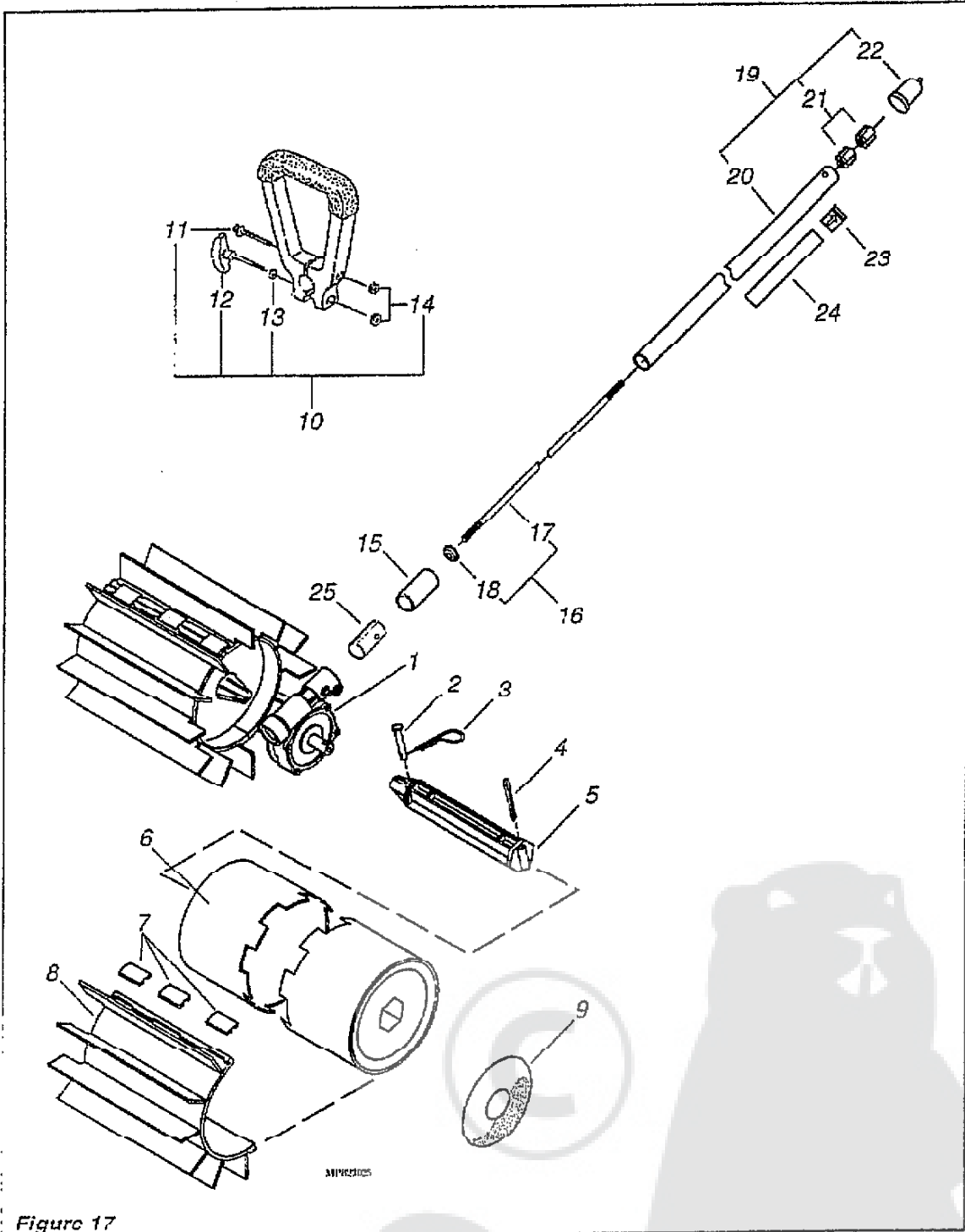

PARTS LIST

Index	Part Number	Part Name	Qty.
1	44444	GEARCASE	1
2	99909-33018	CLEVIS PIN	2
3	99909-33008	HITCH PIN	2
4	99909-33020	COTTER PIN	2
5	99909-33016	DRUM AXLE	2
6	99909-33004	DRUM HUB	4
7	99909-33007	BELT CLIP	12
8	99909-22005	BELT	4
9	61215	LABEL	1
10	72951-14100	HANDLE ASSY.	1
11	72030-14141	BOLT	1
12	72030-14120	KNOB	1
13	72030-14130	WASHER	1
14	01500-06051	NUT	2
15	99909-33034	TUBE PROTECTOR	1
16	65001-62040	MAINSHAFT ASSY.	1
17	37000-62210	MAINSHAFT	1
18	15250-10100	GROMMET	1
19	65001-62010	OUTER PIPE COMP.	1
20	65001-62110	OUTER PIPE	1
21	22035-12120	BUSHING	2
22	20891-98180	LINER CAP	1
23	19401-00169	LABEL, INST.	1
24	80267	LABEL, CAUTION	1
25	72959-13330	SPACER	1

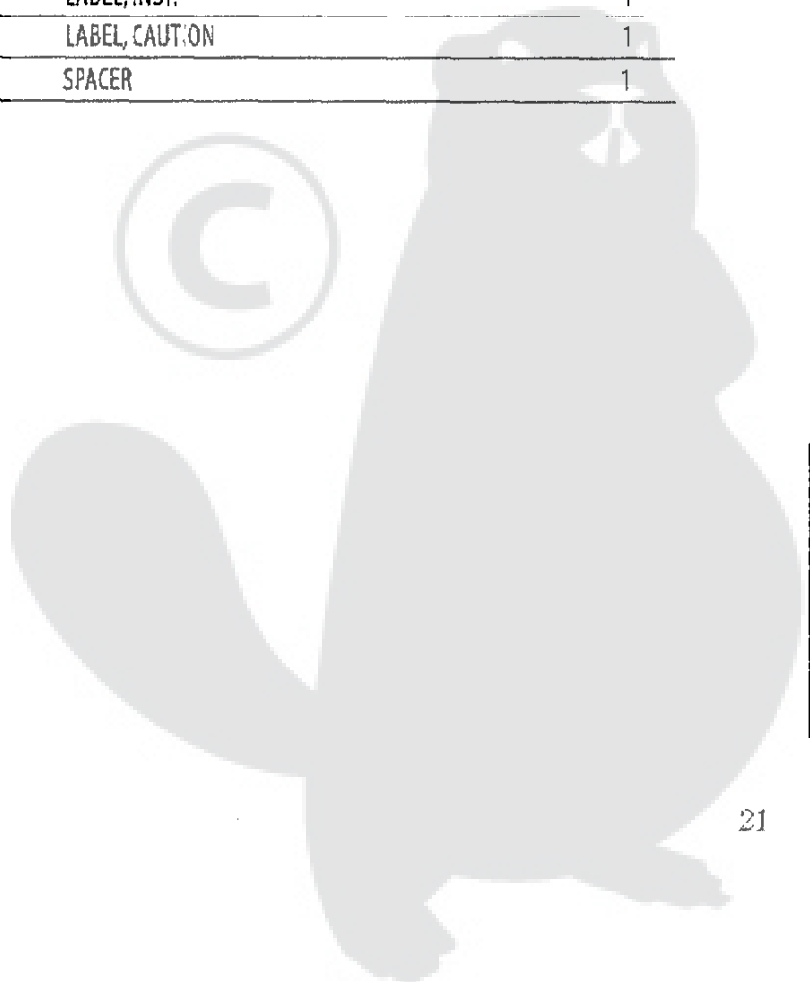

NOTES

(Lined area for writing notes)

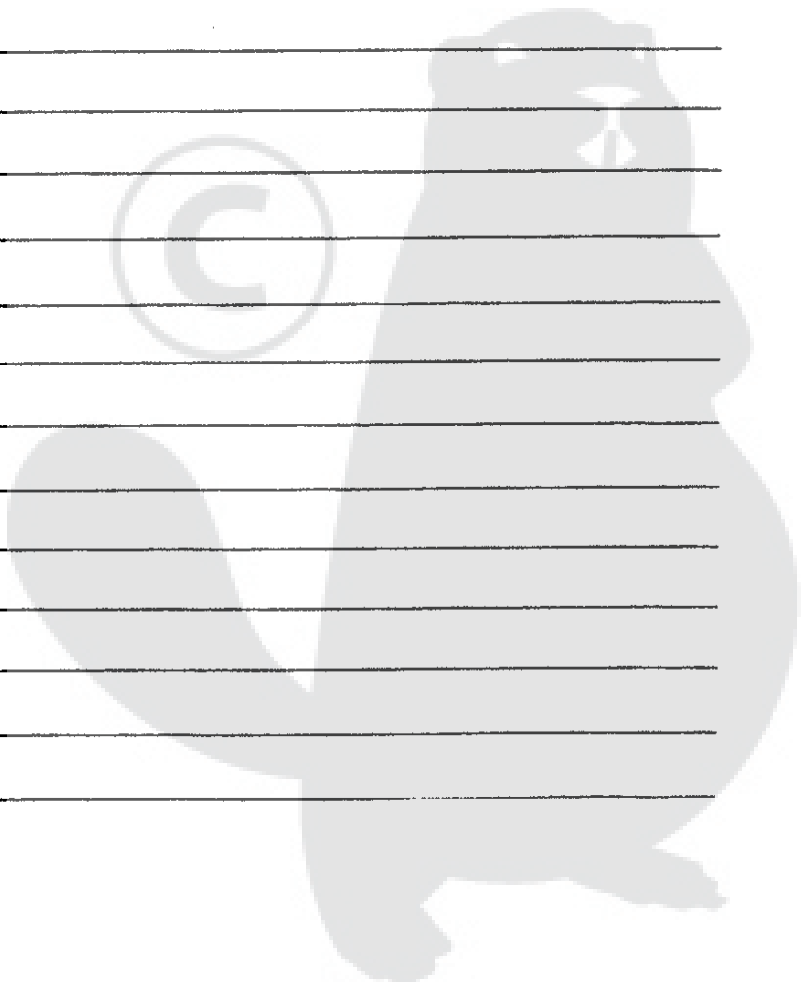

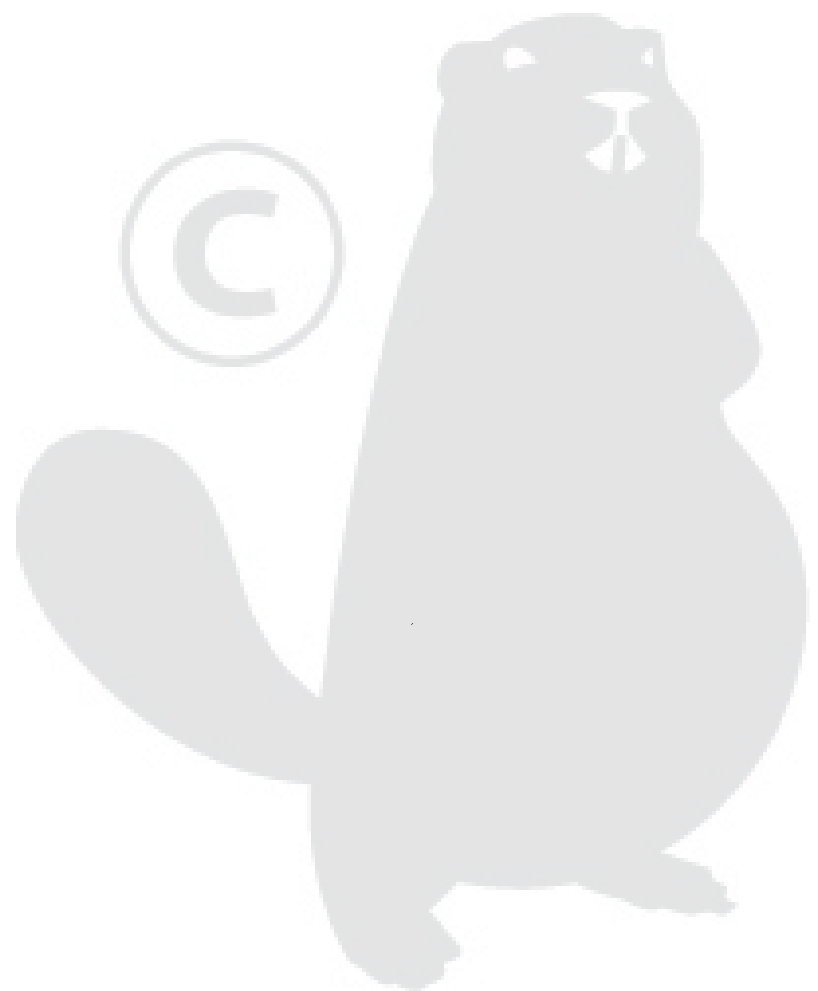

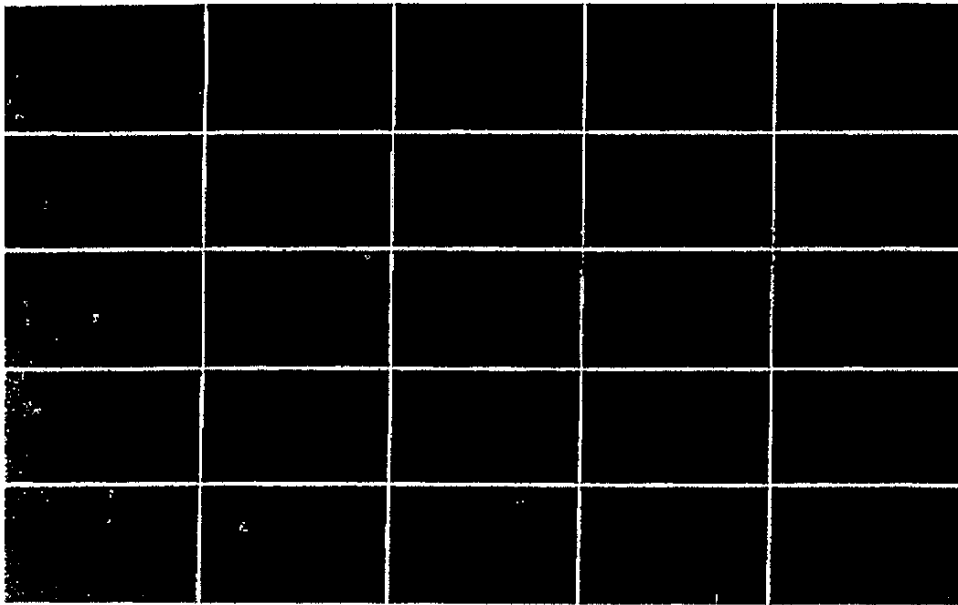

shindaiwa

Shindaiwa Inc.
P.O. Box 2810
Tualatin, Oregon 97062
Telephone 503 692-3070
FAX 503 692-6696
www.shindaiwa.com

Shin-Daiwa Kogyo Co., Ltd.
Head Office: 6-2-11 Ozuka Nishi
Asaminami · KU
Hiroshima, 731-3167, Japan
Telephone: 81-82-672-6011
Fax: 81-82-672-7005

©2001 Shindaiwa, Inc.
Part Number 80273
Printed in USA
Rev. 11/01

Shindaiwa is a registered trademark
of Shindaiwa, Inc.
Specifications subject to change without notice.

