

**SHINDAIWA OWNER'S/
OPERATOR'S MANUAL**

**DH220 DOUBLE-SIDED
HEDGE TRIMMER**



WARNING! Read this manual and familiarize yourself with its contents.



This machine is designed for trimming hedge

Do not use this machine for other purposes.

Minimize the risk of injury to yourself and others.

Do not operate or service this machine unless you clearly understand this manual.

Keep this manual at a particular place so that you can reread it whenever you have a question about its use.

Part Number 68127-94310 Rev. 8/04

shindaiwa

Introduction

The Shindaiwa DH220 series of hand power tools has been designed and built to deliver superior performance and reliability without compromise to quality, comfort, or durability. Shindaiwa high performance engines represent the leading edge of 2-cycle engine technology, delivering exceptionally high power at remarkable low displacement and weight. As an owner/operator, you'll soon discover for yourself why Shindaiwa is simply in a class by itself!

IMPORTANT!

The information contained in this manual describes machines available at the time of publication.

While every attempt has been made to give you the very latest information about your Shindaiwa product, there may be some differences between your machine and what is described here. Shindaiwa reserves the right to make changes to products without prior notification, and without obligation to make alterations to machines previously manufactured.

Contents

	PAGE
Introduction	2
Attention Statements	2
Safety Precautions	3
Operational Precautions	4
General Safety Instructions	4
Product Description	5
Specifications	5
Operating the Hedge Trimmer	6
Throttle Cable Adjustment	6
Mixing Fuel.....	7
Filling the Fuel Tank.....	7
Starting Procedure.....	8
Starting a Flooded Engine.....	9
Stopping the Engine	10
Engine Idle Adjustment	10
General Maintenance.....	10
Long Term Storage.....	12
Muffler Maintenance.....	13
Cutter Blade Adjustment	13
Troubleshooting Guide	14
Declaration of Conformity	17

Attention Statements

Throughout this manual are special "attention statements" surrounded by boxes and preceded by the triangular Attention Symbol.



WARNING!

A statement preceded by the triangular attention symbol and the word "WARNING" contains information that should be acted upon to prevent serious bodily injury.

CAUTION!

A statement preceded by the word "CAUTION" contains information that should be acted upon to prevent mechanical damage.

IMPORTANT!

A statement preceded by the word "IMPORTANT" is one that possesses special significance.

NOTE:

A statement preceded by the word "NOTE" contains information that is handy to know and may make your job easier.



Read and follow this manual and make sure anyone using the hedge trimmer does likewise. Failure to do so could result in serious injury or machine failure. Keep this manual for future reference.



Always wear eye and hearing protection during the operation of this hedge trimmer. A hard hat will provide additional security against falling debris.



Sound Power Level (measure in accordance with 2000/14/EC)

IMPORTANT!

The operational procedures described in this manual are intended to help you get the most from your machine, and to protect you and others from harm. These procedures are guidelines for safe operation under most conditions, and are not intended to replace any safety rules and/or laws that may be in force in your area. If you have questions regarding your machine, or if you do not understand something in this manual, your Shindaiwa dealer will be glad to assist you.



Safety Precautions

Work Safety

Hedge trimmers operate at very high speeds and can do serious damage or injury if they are misused or abused. *Never allow a person without training or instruction to operate this unit!*



WARNING!
THE HEDGE TRIMMER IS NOT INSULATED AGAINST ELECTRICAL SHOCK!

Approaching or contacting an electric fence, power line or other electrified object could cause death or serious injury.

Keep the hedge trimmer at least 10 meters (33 feet) away from electrified objects or branches that contact them.



WARNING!
The engine exhaust from this product contains substances which are harmful to your health.

Stay Alert

You must be physically and mentally fit to operate this unit safely.



WARNING!

- Do not operate the hedge trimmer if you are tired, ill, or under the influence of alcohol, drugs, or medication.
- Keep bystanders at least 5 meters (15 feet) away from the working area during operation to reduce their risk of being cut by the cutters or struck by thrown debris. Stop working immediately if a person, especially a small child or animal comes within the 5 meters zone.
- The blades are sharp-handle them with care! Wearing heavy-duty gloves will go a long way toward protecting your hands.
- Keep your hands clear of the cutter blades when starting the engine, and anytime the engine is running.
- THIS MACHINE CAN CAUSE SERIOUS INJURIES. Read the instructions carefully for the correct handling, preparation, maintenance, starting and stopping of the machine. Be familiar with all controls and the proper use of the machine.

Operational Precautions



WARNING!

- NEVER allow any person to operate this hedge trimmer who has not been properly trained or instructed.
- NEVER smoke or light fires near the hedge trimmer. Keep the hedge trimmer away from excessive heat. Engine fuel is very flammable!
- Before starting the engine move 3 meters (10 feet) away from the fuel storage area or other readily flammable materials. Do not put flammable materials close to the muffler.
- NEVER run the engine indoors, Make sure there is always good ventilation when running the engine. Engine exhaust contains deadly poisonous carbon monoxide gas.
- ALWAYS stop the engine before refueling, and let the engine cool before refueling.
- Do not overfill the fuel tank. Wipe off any spilled fuel immediately. After refueling, inspect the tank to make sure its cap is threaded on properly. Make sure there are no fuel leaks.
- Stop the engine immediately if the hedge trimmer suddenly begins to vibrate or shake. Inspect for broken, missing, or improperly installed parts or components. Correct the problem before returning the hedge trimmer to service.
- ALWAYS disconnect the spark plug wire before performing any maintenance work.
- ALWAYS maintain the hedge trimmer according to this owner's manual and follow the recommended maintenance schedule.
- NEVER modify or disable any of the hedge trimmer's safety devices.
- ALWAYS use genuine Shindaiwa parts and accessories when repairing or maintaining this hedge trimmer. These components have been manufactured specifically for use on this unit and meet the specifications for performance and safety.
- Make sure the cutters are correctly adjusted before operating the hedge trimmer.
- NEVER attempt to adjust the cutter with the engine running.
- NEVER use a cracked or broken cutter or cutter bar; replace it with a new or serviceable one.
- Make sure the powerhead is clean and that the engine cooling fins and muffler are unobstructed and free of debris and loose vegetation.
- Do not operate the hedge trimmer with the muffler removed.
- When transporting or storing the hedge trimmer, make sure the blade cover is attached to the cutter.
- Always ensure all handles and guards are attached and secure when using the machine.

General Safety Instructions

Note the locations of fence posts and other fixed objects and avoid cutting them.

Always wear hearing protection such as earmuffs or earplugs.

Secure long hair so it is above shoulder level.

Do not wear jewelry or loose clothing that could get caught in machinery or brush.

Make sure handgrips are free of foreign substances such as lubricant and pitch.

Wear appropriate clothing. It should fit snugly to minimize snagging yet permit free movement. Never wear shorts when operating the hedge trimmer.

Always be aware of your surroundings and stay alert for possible hazards that you may not hear due to the noise of the machine.

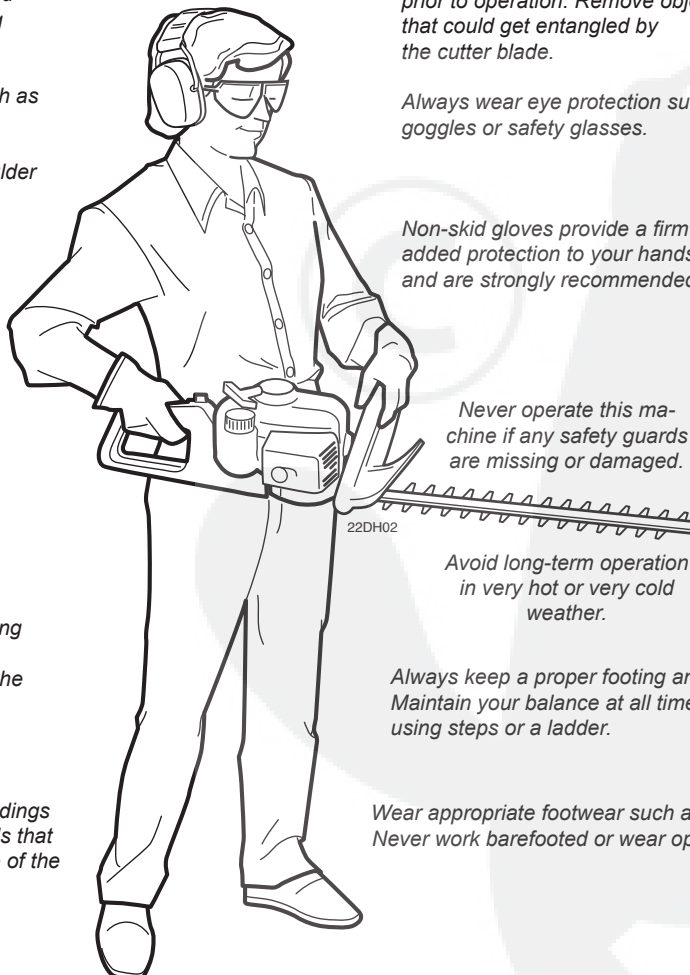

Inspect the cutting site thoroughly prior to operation. Remove objects that could get entangled by the cutter blade.

Always wear eye protection such as goggles or safety glasses.

Non-skid gloves provide a firm grip, added protection to your hands, and are strongly recommended.

Never operate this machine if any safety guards are missing or damaged.

Avoid long-term operation in very hot or very cold weather.

Always keep a proper footing and do not overreach. Maintain your balance at all times during operation especially when using steps or a ladder.

Wear appropriate footwear such as non-skid boots or shoes. Never work barefooted or wear open-toed shoes or sandals.

Avoid cutting large or extremely woody branches. Doing so can shorten cutter life and damage the gearcase.

Before moving to another job site, stop the engine and install the blade cover.

Always operate with both hands firmly gripping the handgrips of the machine.

Do not allow the cutters to contact buildings or other hard objects during operation.

If a cutter should bind fast in a cut, stop the engine immediately. Remove the cause of the bind before proceeding.

Never cut metal objects or wire with the blade.

Never allow children to use the machine. Avoid operating near bystanders.

Product Description

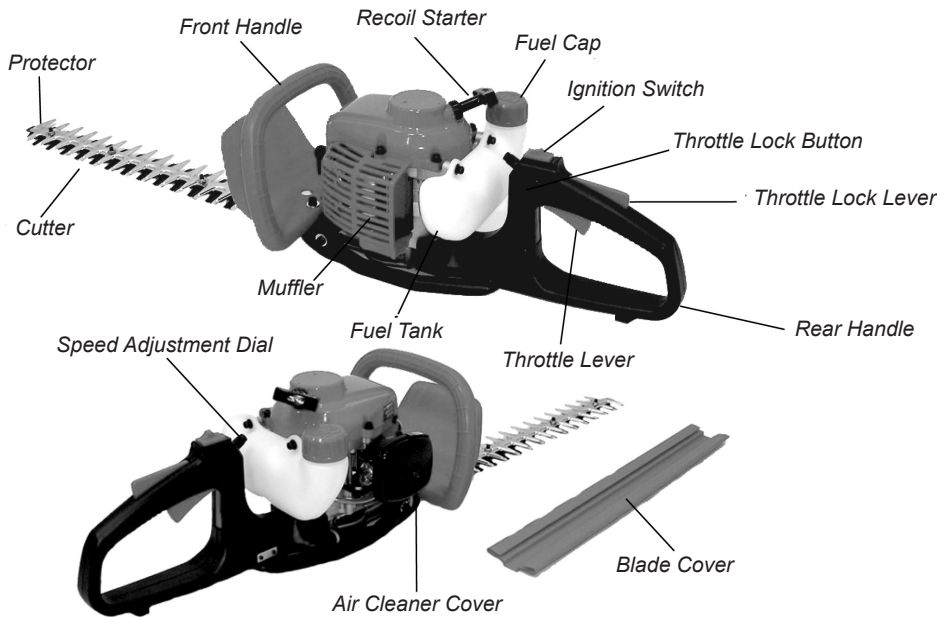

This hedge trimmer is supplied fully assembled. Before proceeding, inspect the unit to make sure components are in place and that fasteners are tight. Inspect for broken, damaged or missing parts or components.

IMPORTANT!

The terms “left,” “left-hand,” and “LH”; “right,” “right-hand,” and “RH”; “front” and “rear” refer to directions as viewed by the operator during normal operation of this product.

Familiarize yourself with your machine and its various components. Understanding your machine helps ensure top performance, long service life, and safer operation.



WARNING!

Do not make unauthorized modifications or alterations to this machine or any of its components or accessories.

Specifications

Model Name	DH220/EC1
Engine Model	SDH220EC1
Engine Type	2-cycle, horizontal cylinder, air cooled
Engine Displacement	21.1 cm ³
Bore x Stroke	31mm x 28mm
Engine Speed at Idling	3,100 min ⁻¹ (rpm)
Engine Speed at Maximum Power Output	7,500 min ⁻¹ (rpm)
Maximum Power Output	0.6 kW
Maximum Engine Speed	11,000 min ⁻¹ (rpm)
Ignition System	Fully Electronic, transistor-controlled
Spark Plug	NGK BMR6A
Starting Method	Recoil Starter
Stopping Method	Slide Switch
Air Cleaner	Semi-wet
Fuel/Oil Ratio	50:1
Fuel Tank Capacity	400 cm ³
Carburetor Type	Walbro, WYL
Dry Weight	4.7 kg
Dimensions (L x W x H)	980mm x 245mm x 210mm
Sound Pressure Level*	Idling 82 dB (A) - Racing 99dB (A)
Sound Power Level*	Idling 90 dB (A) - Racing 106 dB (A)
Vibration Level (Front/Rear)	Idling - 7.4/6.5 (m/s ²)
Vibration Level* (Front/Rear)	Racing - 5.5/11.8 (m/s ²)

* Sound Pressure Level: in accordance with ISO 11201

* Sound Power Level: in accordance with ISO 3744

* Vibration Level: in accordance with EN 28662-1

Standard equipment, rear handle with integrated controls. Front and rear handle with anti-vibe mountings. Front handle with guard. Tool set which includes combination spark plug 13mm wrench, and blade cover.

Specifications subject to change without notice.

Operation of the Hedge Trimmer

■ Squeezing the throttle increases engine speed, causing the clutch to engage and operate the cutters.

■ Releasing the throttle decreases engine speed, causing the cutters to slow, and then stop altogether as the clutch disengages.

■ Speed adjustment, turning the maximum speed adjustment dial counterclockwise decreases the engine speed when the throttle is fully squeezed. Adjust the maximum engine speed to suit your work. (The maximum speed adjustment dial is preset on its maximum speed position at the factory.)



■ Use a sweeping motion when cutting, and vary throttle settings often.

■ Trim the hedge swinging the blade as the illustration shows. At vertical cutting the hedge trimmer is used with circular pendulation, swinging up and down close to the hedge.

■ Avoid cutting material larger than 1.2 cm (1/2 inch) in diameter. Do not cut metal objects or wire.

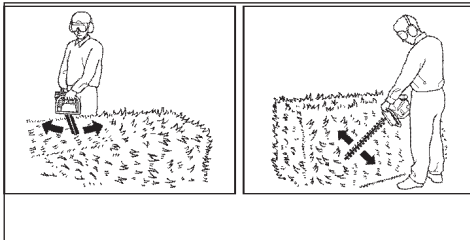

Throttle Cable Adjustment

1. This hedge trimmer is supplied fully assembled. To make sure the unit operates correctly, check the throttle lever:

- The throttle lever should operate smoothly without binding.
- The throttle lever should have about 5-10mm (1/4-inch) free play when the engine is not running.



2. If free play adjustment is required, loosen the two 10mm throttle cable nuts at the cable holder.

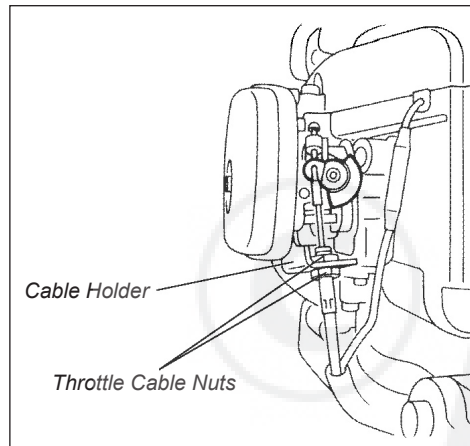

3. Adjust the throttle cable nuts until you achieve correct throttle free play, then tighten the jam nuts securely.

4. When 5-10mm (1/4-inch) free play is achieved, tighten the two 10mm throttle cable nuts. When the throttle cable is correctly adjusted, and the throttle trigger is fully depressed (full throttle position), the throttle will contact the stop on the throttle body.

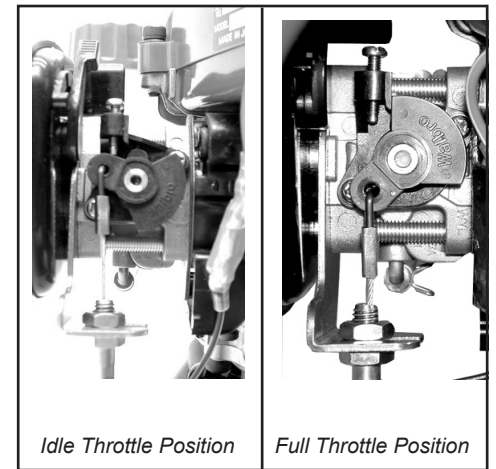

Mixing Fuel

CAUTION!

This engine is certified to operate on a 50:1 mixture consisting of unleaded gasoline and 2-cycle mixing oil only.

Some gasolines contain alcohol as an oxygenate! Oxygenated fuels may cause increased operating temperatures. Under certain conditions, alcohol-based fuels may also reduce the lubricating qualities of some mixing oils. Never use any fuel containing more than 10% alcohol by volume! When an oxygenated fuel must be used, a fuel containing MTBE is to be preferred over an alcohol based fuel.

Generic oils and some outboard motor oils may not be intended for use in high-performance air cooled 2-cycle engines, and should never be used in your Shindaiwa engine!

- Mix all fuel with 2-cycle Engine Oil and gasoline at a gasoline/mixing oil ratio of 50:1.
- Use only fresh, clean unleaded gasoline with an octane rating of 87 or above.

IMPORTANT!

Mix only enough fuel for your immediate needs! If fuel must be stored longer than 30 days, it should first be treated with a stabilizer such as StaBil™.

Filling the Fuel Tank



WARNING!

Minimize the risk of fire!

- Handle fuel with extreme care since it is highly flammable!
- Always allow the engine to cool before refueling!
- Wipe all spilled fuel and move the machine at least 3 meters (10 feet) from the fueling point before restarting!
- Never smoke or light any fires near the unit or fuels!
- Never place any flammable material near the engine muffler!
- Never operate the unit without the muffler in place and properly functioning!
- Never operate the unit if fuel system components are damaged or are leaking.



WARNING!

Do not inhale fuel fumes as they are toxic!

1. Place the unit on the ground or on a flat surface.
2. Clear any dirt or other debris from around the fuel filler cap.
3. Remove the fuel cap slowly, and fill the fuel tank with clean, fresh fuel mixture.
4. Replace and firmly tighten the fuel cap.
5. Wipe up any spilled fuel from the powerhead before starting the engine.

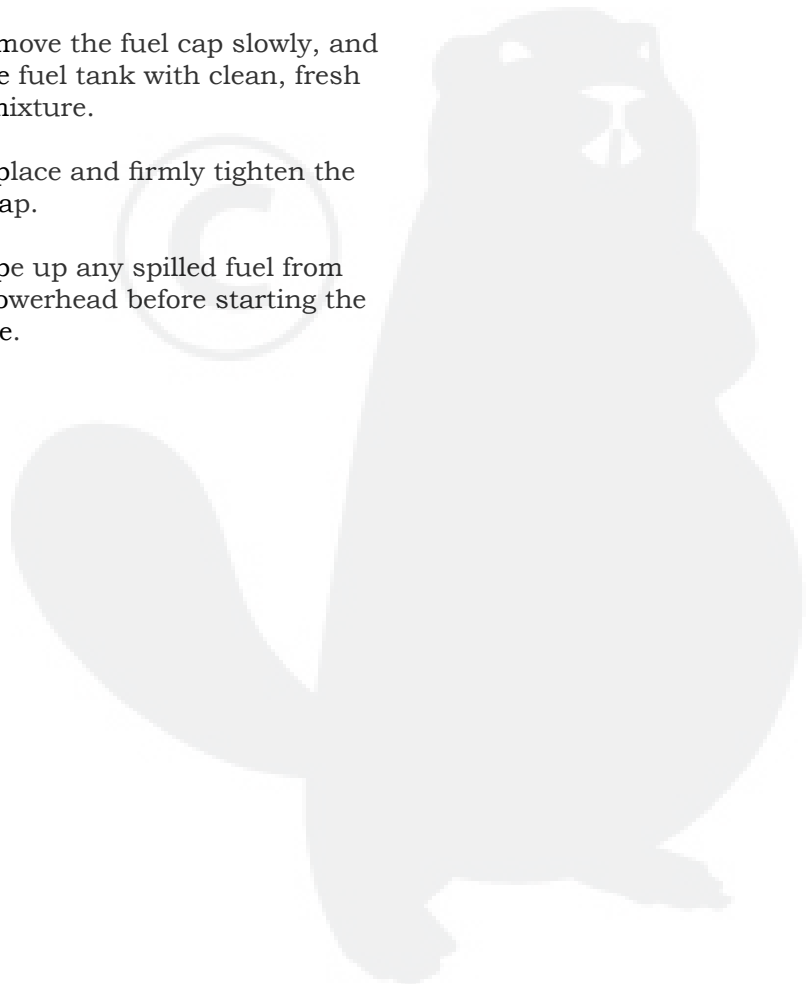
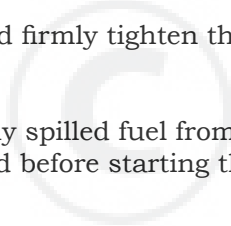

Starting Procedure

Control Positions (Cold Engine)

1. Move the ignition switch rearward to the "I" or START position.

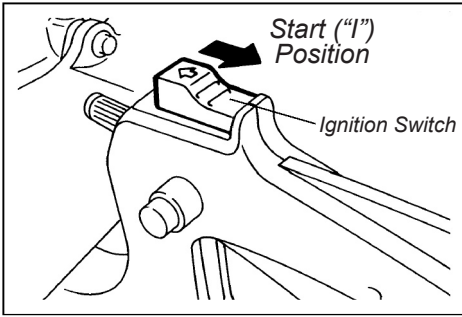

2. Set the throttle lever to the "fast idle" position by performing the following.
 - a. Depress and hold the throttle lockout lever, then squeeze the throttle lever.
 - b. Depress and hold the throttle lock button.
 - c. While depressing the throttle lock button, release the throttle lockout lever and throttle lever.

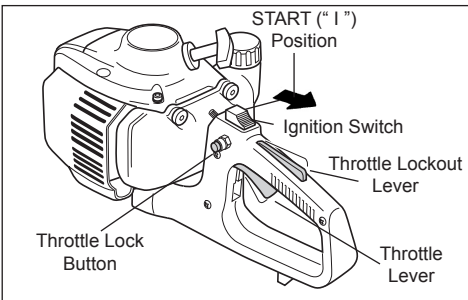

3. Prime the carburetor by depressing the carburetor primer bulb 4 or 5 times until you see clear fuel flowing through the transparent primer bulb.

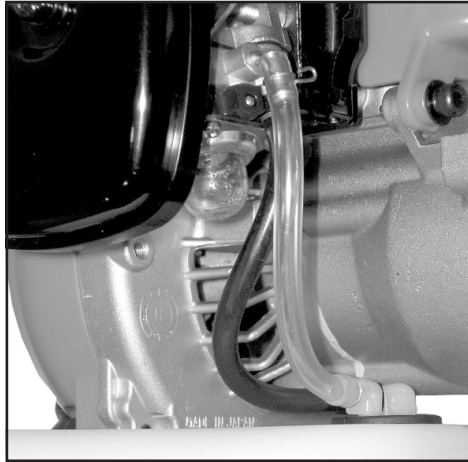

4. Move the choke lever *forward* to the "closed" position to choke the engine.

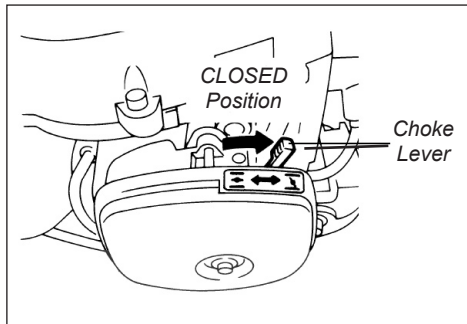

WARNING!

KEEP CLEAR OF THE CUTTING ATTACHMENT DURING STARTING OPERATIONS! THE CUTTERS MAY MOVE WHEN THE ENGINE IS STARTED

- Place the trimmer on the ground during all starting operations.
- Make sure you have a secure footing, and keep a firm grip on the machine as well.
- Keep all bystanders and pets well clear of the trimmer during starting operations.

IMPORTANT!

Engine ignition is controlled by a two-position switch mounted on the throttle body labeled "I" for ON or START and "O" for OFF or STOP.

Control Positions

(Warm Engine)

1. Move the ignition stop switch rearward to the “I” or START position.
2. Set the throttle lever to the fast idle position as in Step 2, previous page.
3. Move the choke lever *back* (rearward) to the “open” position.

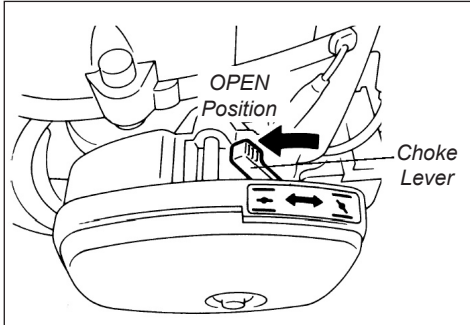

Start the Engine

1. Place the machine on the ground. Grip the engine cover with your left hand and the starter handle with your right hand.
2. Pull the starter handle slowly toward you until you feel the starter mechanism engage.
3. Start the trimmer by pulling the starting handle rapidly outward.



CAUTION!

The recoil starter can be easily damaged by abuse.

- Always engage the starter before attempting to crank the engine.
- Never pull the starter cord to its full length.
- Always rewind the starter cord slowly.

When the engine starts or fires...

1. Open the choke by moving the choke lever *backward* (toward the fuel tank).
 2. If the engine does not continue to run, repeat the appropriate starting procedures for a cold or warm engine.
 3. When the engine starts, clear excess fuel from the combustion chamber by accelerating the engine several times with the throttle lever.
 4. Operating the throttle will automatically disengage the fast idle setting.
2. If the spark plug is fouled or is soaked with fuel, clean or replace the plug as necessary. For spark plug specifications and gapping procedure. See Page 11.
 3. Set the ignition switch to the “O” or STOP position and open the choke. Fully depress the throttle lever with your left hand and pull the starter handle rapidly with your right hand several times to clear excess fuel from the engine combustion chamber.

If the engine does not start

- Repeat the appropriate starting procedure for a cold or warm engine.
- If the engine still fails to start, use the procedures for “Starting a Flooded Engine”.



WARNING!

The cutting attachment will move when the engine accelerates!

Starting a Flooded Engine

1. Disconnect the spark plug lead, then use the spark plug wrench to remove the spark plug (counterclockwise to remove).

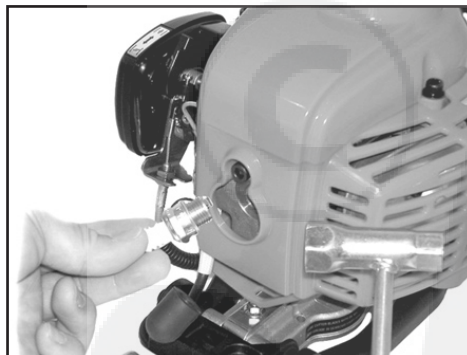

WARNING!

Move the ignition switch forward to the “O” or STOP position.



WARNING!

Burn danger from hot engine! Allow engine to cool before removing spark plug.

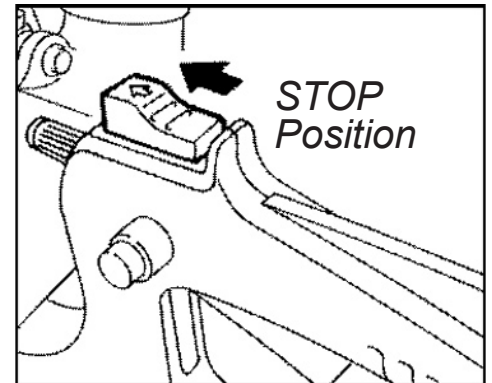

4. Replace the spark plug and tighten it firmly with the spark plug wrench. If a torque wrench is available, torque the spark plug to 16.7-18.6 N·m (170-190 kg-cm).
5. Repeat the starting procedures for a warm engine.
6. If the engine still fails to start or fire, refer to the troubleshooting chart at the end of this manual.

CAUTION!

Incorrect spark plug installation can result in serious engine damage!

Stopping the Engine

1. Cool the engine by allowing it to idle for 2 - 3 minutes.
2. Move the ignition switch forward to the "O" or STOP position.

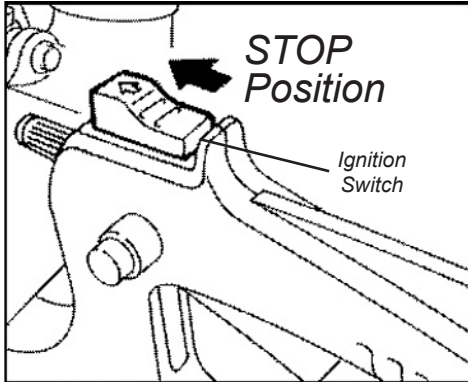

WARNING!

The cutters can continue oscillating after the engine is switched off.



WARNING!

Know how to stop the machine quickly in an emergency.

Engine Idle Adjustment

The engine must return to idle speed whenever the throttle lever is released. Idle speed is adjustable, and must be set low enough to permit the engine clutch to disengage the cutters.

Idle Speed Adjustment



WARNING!

The cutters must NEVER engage at engine idle speeds! If the idle speed cannot be adjusted by the procedure described here, return the trimmer to your dealer for inspection.

1. Place the unit on the ground, then start the engine, and then allow it to idle 2-3 minutes until warm.
2. If the cutters move when the engine is at idle, reduce idle speed by turning the idle adjustment screw counterclockwise.

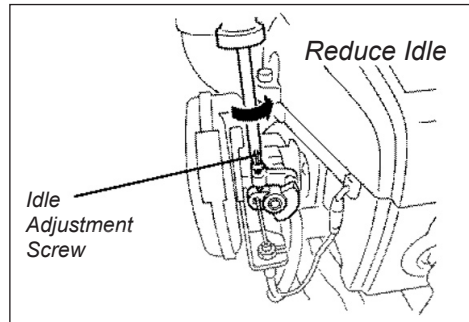

3. If a tachometer is available, the engine idle speed should be adjusted to $3,100 \text{ min}^{-1}$ (rpm).
4. Carburetor fuel mixture adjustments are preset at the factory and cannot be serviced in the field.
5. Clean up any fuel that may have spilled.

General Maintenance

IMPORTANT!

MAINTENANCE, REPLACEMENT OR REPAIR OF EMISSION CONTROL DEVICES AND SYSTEMS MAY BE PERFORMED BY ANY REPAIR ESTABLISHMENT OR INDIVIDUAL; HOWEVER, WARRANTY REPAIRS MUST BE PERFORMED BY A DEALER OR SERVICE CENTER AUTHORIZED BY SHINDAIWA KOGYO CO., LTD. THE USE OF PARTS THAT ARE NOT EQUIVALENT IN PERFORMANCE AND DURABILITY TO AUTHORIZED PARTS MAY IMPAIR THE EFFECTIVENESS OF THE EMISSION CONTROL SYSTEM AND MAY HAVE A BEARING ON THE OUTCOME OF A WARRANTY CLAIM.



WARNING!

Before performing any maintenance, repair or cleaning work on the unit, make sure the engine and cutting attachment are completely stopped. Disconnect the spark plug wire before performing service or maintenance work.



WARNING!

Nonstandard parts may not operate properly with your unit and may cause damage and lead to personal injury.

NOTE:

Using nonstandard replacement parts could invalidate your Shindaiwa warranty.

Daily Maintenance

Prior to each work day, perform the following:



WARNING!

To reduce fire hazard, keep the engine and muffler free of debris, leaves, or excessive grease.

- Lubricate the cutters with oil before use, and after refueling.
- Check the cutters for damage or improper adjustment, and adjust or replace as necessary.
- Carefully remove any accumulations of dirt or debris from the muffler and fuel tank. Dirt build-up in these areas can lead to engine overheating, fire, or premature wear.
- Clean any debris or dirt from the hedge trimmer cutter blades. Lubricate the blades before use and after refueling. Check the cutters for damage or incorrect adjustment.
- Check for loose or missing screws or components. Make sure the cutter attachment is securely fastened.

Muffler

Muffler

This unit must never be operated with a faulty or missing spark arrestor or muffler. Make sure the muffler is well secured and in good condition. A worn or damaged muffler is a fire hazard and may also cause hearing loss.

Spark Plug

Keep the spark plug and wire connections tight and clean.

Fasteners

Make sure nuts, bolts, and screws (except carburetor adjusting screws) are tight.

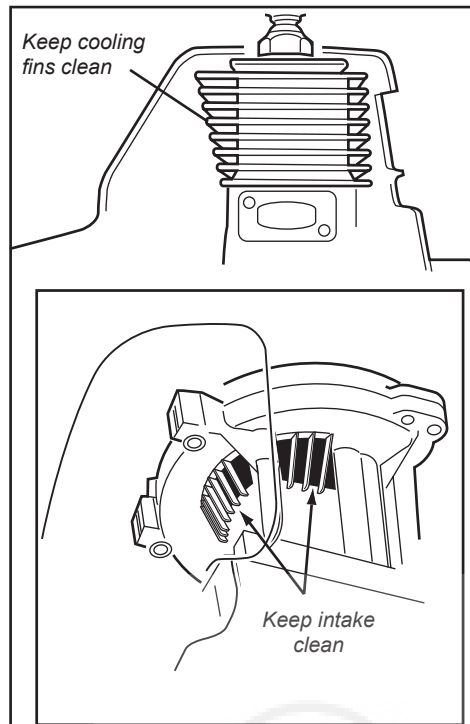

10-15 Hour Maintenance

CAUTION!

Do not operate the unit if the air cleaner or element is damaged, or if the element is wet.

Every 10 hours of operation, (more frequently in dusty or dirty conditions):

Remove the air cleaner element from the air cleaner housing and clean it thoroughly with soap and water. Rinse and dry thoroughly. Add a few drops of oil and work it in, then reassemble.

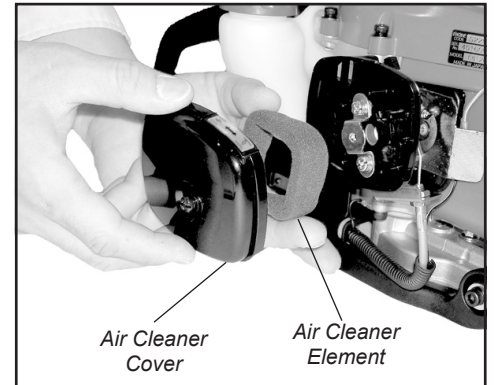

CAUTION!

Before removing the spark plug, clean the area around the plug to prevent dirt and debris from getting into the engine's internal parts.

Every 10 to 15 hours of operation:

- Remove and clean the spark plug. Adjust the spark plug electrode gap to 0.6 mm (0.024-inch). If the plug must be replaced, use only: NGK BMR6A or an equivalent spark plug of the correct heat range.

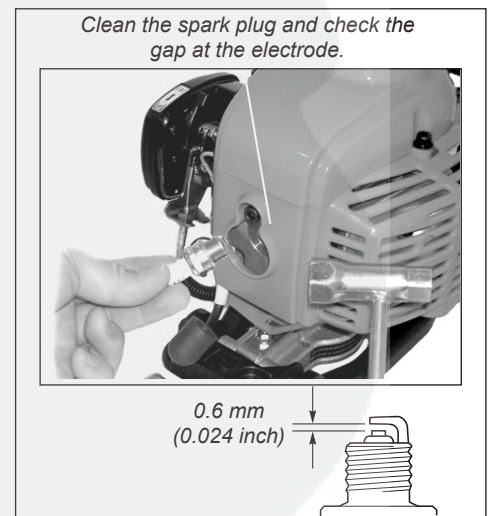
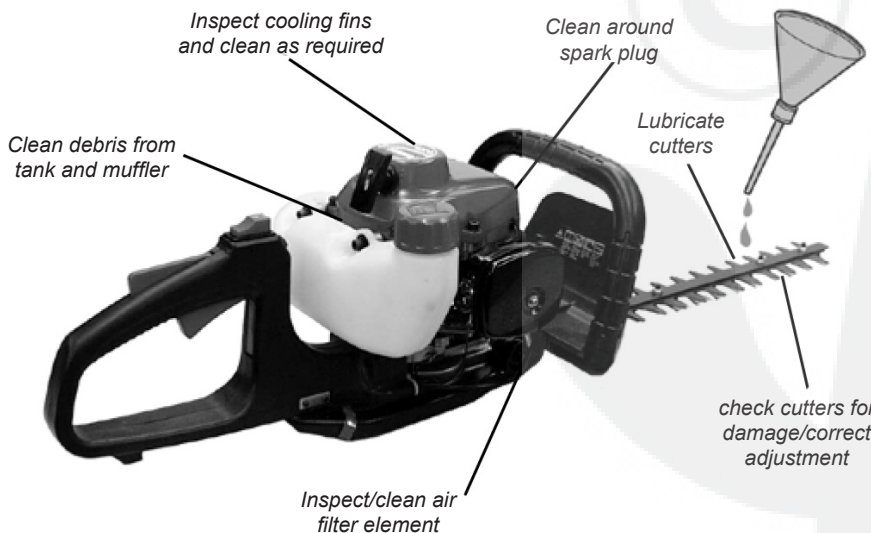

Gearcase Lubrication Schedule

CAUTION!

Over-lubricating may cause the gearcase to run slower than normal, and may also cause leakage from excess grease.

Every 20 Hours

Connect a grease gun to the grease fitting on the left side of the gearcase. Top off the gearcase grease level by adding a high quality lithium-based grease. Three pumps of the grease gun handle should be adequate. DO NOT OVERFILL THE GEARCASE!

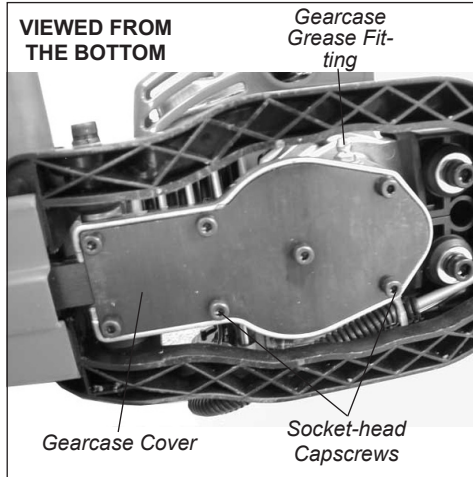

50-Hour Maintenance

(more frequently in dusty or dirty conditions before long-term storage):

Remove the gearcase cover. Use solvent and a soft brush to remove all old grease from the gearcase. To refill, hand-pack the gearcase with approximately 40–50 grams of high quality lithium-based grease (50–70% of capacity). DO NOT OVERFILL!

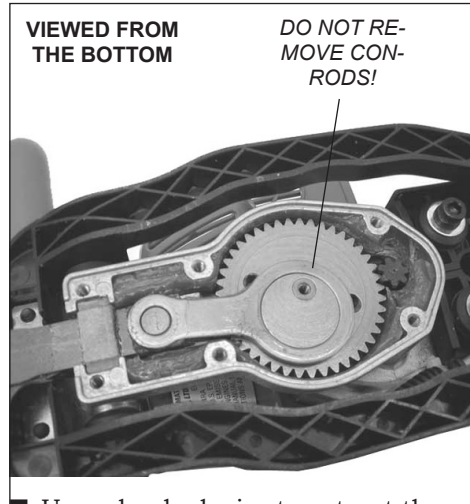

■ Use a hooked wire to extract the fuel filter from inside the fuel tank. Inspect the fuel filter element. If it shows signs of contamination from debris, replace it with a genuine Shindaiwa replacement fuel filter element. Before reinstalling the filter, inspect the fuel line. If you discover damage or deterioration, the unit should be removed from service until it can be inspected by a Shindaiwa-trained service technician.

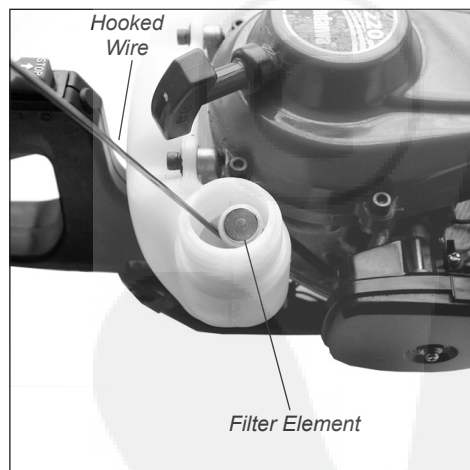

CAUTION!

Make sure you do not pierce the fuel line with the end of the hooked wire. The line is delicate and can be damaged easily.

Long Term Storage

(30 days or longer)

CAUTION!

Never store this unit with any fuel remaining in the tank, fuel lines or carburetor!

NOTE:

Your Shindaiwa warranty does not include coverage for damage caused by stale or contaminated fuels.

- Thoroughly clean the exterior of the machine.
- Remove all clippings and other debris from the cylinder fins and other components (as previously described under Daily Maintenance).
- Drain all unused fuel from the fuel tank, and then clear the carburetor and fuel lines by running the trimmer until it stops from lack of fuel.

IMPORTANT!

All stored fuel should be stabilized with fuel stabilizer such as STA-BIL™

- Remove the spark plug, and pour about 7 grams of 2-cycle mixing oil into the cylinder through the spark plug hole. Before reinstalling the spark plug, slowly pull the recoil starter 2–3 times to distribute the oil over the cylinder wall.
- Service the air cleaner element as previously described in the daily maintenance section of this manual.
- Repair or replace any damaged components as required, and then store the unit in a clean, dry, and dust-free area.

Muffler Maintenance

Seasonally (or whenever you experience hard starting or poor performance):

- Hard starting or a gradual loss of performance can be caused by carbon deposits lodged in the muffler's spark arrester screen. Remove the screen from the muffler with the point of a small pliers. Thoroughly clean the screen with a stiff bristle brush. A damaged or otherwise unserviceable screen must be replaced. Reinstall by gently tapping the screen in place.
- If carbon accumulations in the muffler or cylinder are severe or if you do not notice an improvement in performance after servicing, return the trimmer to your Shindaiwa dealer for inspection.

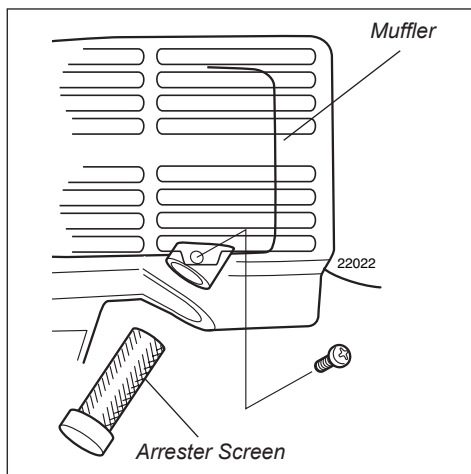

WARNING!

Never operate this machine with a damaged or missing muffler or spark arrester! Operating with missing or damaged exhaust components is a fire hazard, and may also damage your hearing.

Cutter Adjustment

Cutter performance of this unit depends in great measure on cutter blade clearance. Properly adjusted blades will oscillate freely yet help prevent binding of cut material between blades. Adjust blades as follows:

1. Loosen all blade locknuts at least one full turn.
2. Tighten each blade shoulder bolt firmly, and then loosen the shoulder bolts 1/4 to 1/2 turn.
3. Working from the gearcase end, lock each bolt in place by firmly tightening its locknut while preventing the shoulder bolt from turning.

When shoulder bolt adjustment is correct, there should be a gap of 0.25–0.50 mm between the cutter blades and the flat washers, and the flat washer beneath each bolt head should turn freely.

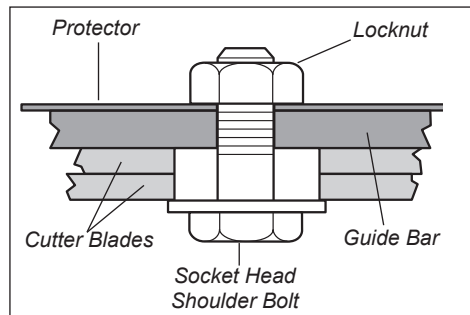

WARNING!

The cutter blades are very sharp! Always wear gloves when working around the cutter as-

CAUTION!

Operating the hedge trimmer with worn or improperly adjusted cutters will reduce cutter performance and may also damage this unit.

Troubleshooting Guide

Engine won't Start

What to Check

Possible Cause

Remedy

Does the engine crank?	NO	Faulty recoil starter. Fluid in the crankcase. Internal damage.	Consult with an authorized Shindaiwa dealer.
↓			
Good compression?	NO	Loose spark plug. Excess wear on cylinder, piston, rings.	Tighten and re-test. Consult with an authorized Shindaiwa dealer.
↓			
Does the tank contain fresh fuel of the proper grade?	NO	Fuel is old or contaminated.	Refill with clean fresh unleaded gasoline with a pump octane of 87 or higher, mixed with a Premium 2-cycle Engine Oil at a 50:1 gasoline/oil ratio. Re-start.
↓			
Is fuel visible and moving in the return line when priming?	NO	Clogged fuel filter and/or vent. Carburetor primer failure.	Clean or replace filter/vent as required. Re-start. Consult with an authorized Shindaiwa dealer.
↓			
Is there spark at the spark plug wire terminal?	NO	The ignition switch is in OFF ("O"). Faulty ignition ground. Faulty transistor unit.	Move switch to ON ("I") and re-start. Consult with an authorized Shindaiwa dealer.
↓			
Check the spark plug.	NO	If the plug is wet, excess fuel may be in the cylinder. The plug may be fouled or improperly gapped.	Crank the engine with the plug removed and the ignition switch off. Replace the plug, and re-start. Clean and re-gap the plug to 0.024 inch (0.6mm). Re-start.

The plug may be damaged internally or is the wrong size.

Replace the plug with a NGK BMR6A. Re-start.



WARNING!
Do not attempt to repair the machine unless you are qualified to do so.



Troubleshooting Guide

Low Power Output

What to Check

Possible Cause

Remedy

Is the engine overheating?	Operator is overworking the unit. Carburetor mixture is too lean. Improper fuel/oil ratio. Fan, fan cover, cylinder fins dirty or damaged. Carbon deposits on the piston or in the muffler.	Cut at a slower rate. Consult with an authorized Shindaiwa dealer. Refill with clean fresh unleaded gasoline with a pump octane of 87 or higher, mixed with a Premium 2-cycle Engine Oil at a 50:1 gasoline/oil ratio. Clean, repair or replace as necessary. Consult with an authorized Shindaiwa dealer.
Engine is rough at all speeds. May also have black smoke and/or unburned fuel at the exhaust.	Clogged air filter. Loose or damaged spark plug. Air leakage or clogged fuel line. Fuel is old or contaminated.	Clean or replace the air filter. Tighten or replace. Repair or replace filter and/or fuel line. Refill with clean fresh unleaded gasoline with a pump octane of 87 or higher, mixed with a Premium 2-cycle Engine Oil at a 50:1 gasoline/oil ratio.
Engine is knocking.	Piston seizure. Faulty carburetor and/or diaphragm. Overheating condition. Improper fuel.	Consult with an authorized Shindaiwa dealer. Consult with an authorized Shindaiwa dealer. See "Overheating" above.

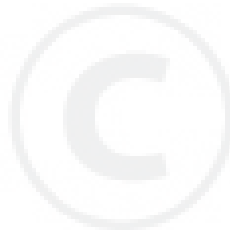

Troubleshooting Guide

Additional Problems

Symptom

Possible Cause

Remedy

Poor acceleration.	<ul style="list-style-type: none">Clogged air filter.Clogged fuel filter.Carburetor mixture too lean.Idle speed set too low.	<ul style="list-style-type: none">Clean the air filter.Replace the fuel filter.Return trimmer to the dealer.Adjust: 3000 (\pm250) rpm (min^{-1})
Engine stops abruptly.	<ul style="list-style-type: none">Switch turned off.Fuel tank empty.Clogged fuel filter.Water in the fuel.Shorted spark plug or loose terminal.Ignition failure.Piston seizure.	<ul style="list-style-type: none">Reset the switch and re-start.Refuel.Replace filter.Drain; replace with clean fuel. (See page 9).Clean and replace spark plug, tighten the terminal.Replace the ignition unit.Consult with an authorized Shindaiwa dealer.
Engine difficult to shut off.	<ul style="list-style-type: none">Ground (stop) wire is disconnected, or switch is defective.Overheating due to incorrect spark plug.Overheated engine.	<ul style="list-style-type: none">Test and replace as required.Clean and regap to 0.024" Correct plug; NGK BMR6AIdle engine until cool.
Cutting attachment rotates at engine idle.	<ul style="list-style-type: none">Engine idle too high.Broken clutch spring or worn clutch spring boss.	<ul style="list-style-type: none">Set idle: 3000 (\pm250) rpm (min^{-1})Replace spring/shoes as required, check idle speed.
Excessive vibration.	<ul style="list-style-type: none">Warped or damaged guide bar or cutters.Damaged gearcase.Shoulder bolts/cutters worn or out of adjustment.	<ul style="list-style-type: none">Inspect and replace as required.Consult with an authorized Shindaiwa dealer.Adjust or replace as required.

DECLARATION OF CONFORMITY

We hereby declare the Shindaiwa Hedge Trimmer,
Model DH220 (DH220/EC1)

meets the following respective requirements.

Council Directives:

89/336/EEC as amended
98/37/EC as amended
2000/14/EC as amended
2002/88/EC as amended

Standard taken:

EN 292 parts 1&2
EN 774
CISPR 12

Measured sound power level: 106dB(A)

Guaranteed sound power level: 108dB(A)

Technical documentation is kept by:

K. Maeda DIV. Manager
Engineering Research and Development DIV.

Shindaiwa Kogyo Co.,Ltd.

Head office : 6-2-11, Ozuka-Nishi, Asaminami-Ku,
Hiroshima, 731-3167, Japan

TEL:81-82-849-2003 , FAX:81-82-849-2482

19th August, 2004

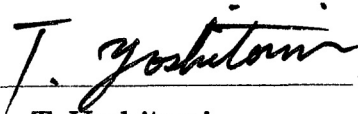

T. Yoshitomi
DIV. Manager
Quality Assurance DIV.

Shindaiwa Kogyo Co.,Ltd.

Head office : 6-2-11, Ozuka-Nishi, Asaminami-Ku,
Hiroshima, 731-3167, Japan

TEL:81-82-849-2206 , FAX:81-82-849-2481





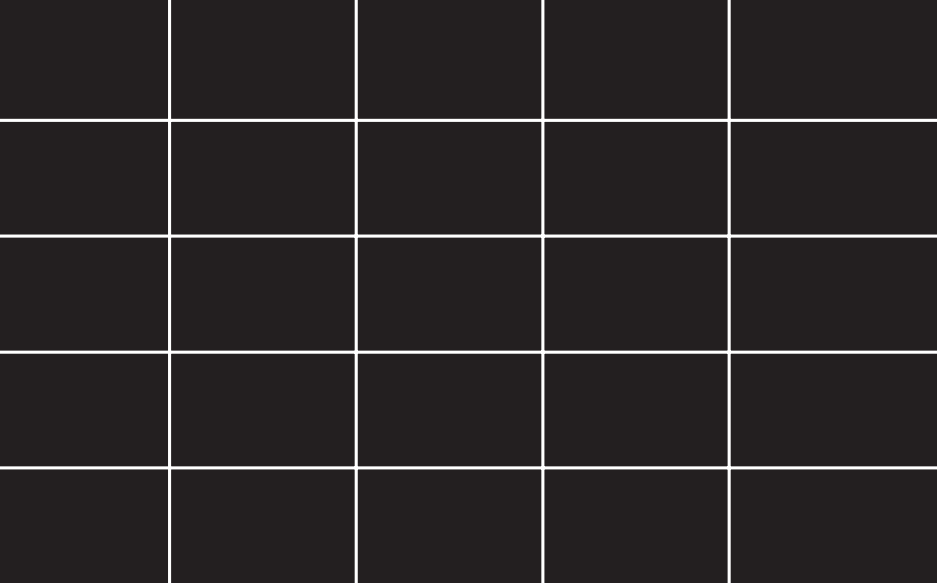

shindaiwa

Shindaiwa Inc.
11975 S.W. Herman Road
Tualatin, Oregon 97062
Telephone: 503 692-3070
Fax: 503 692-6696
www.shindaiwa.com

Shindaiwa Kogyo Co., Ltd.
Head Office: 6-2-11 Ozuka-Nishi,
Asaminami-Ku Hiroshima,
731-3167, Japan
Telephone: 81-82-849-2220
Fax: 81-82-849-2481

© 2004 Shindaiwa, Inc.
Part Number 68127-94310
Revision 8/04
Printed in Japan

Shindaiwa Tornado is a trademark,
and Shindaiwa is a registered trademark
of Shindaiwa, Inc.
Specifications subject to change without notice.

