

SHINDAIWA OWNER'S/OPERTOR'S MANUAL

**T350 GRASS TRIMMER
C350/B450 BRUSHCUTTER**

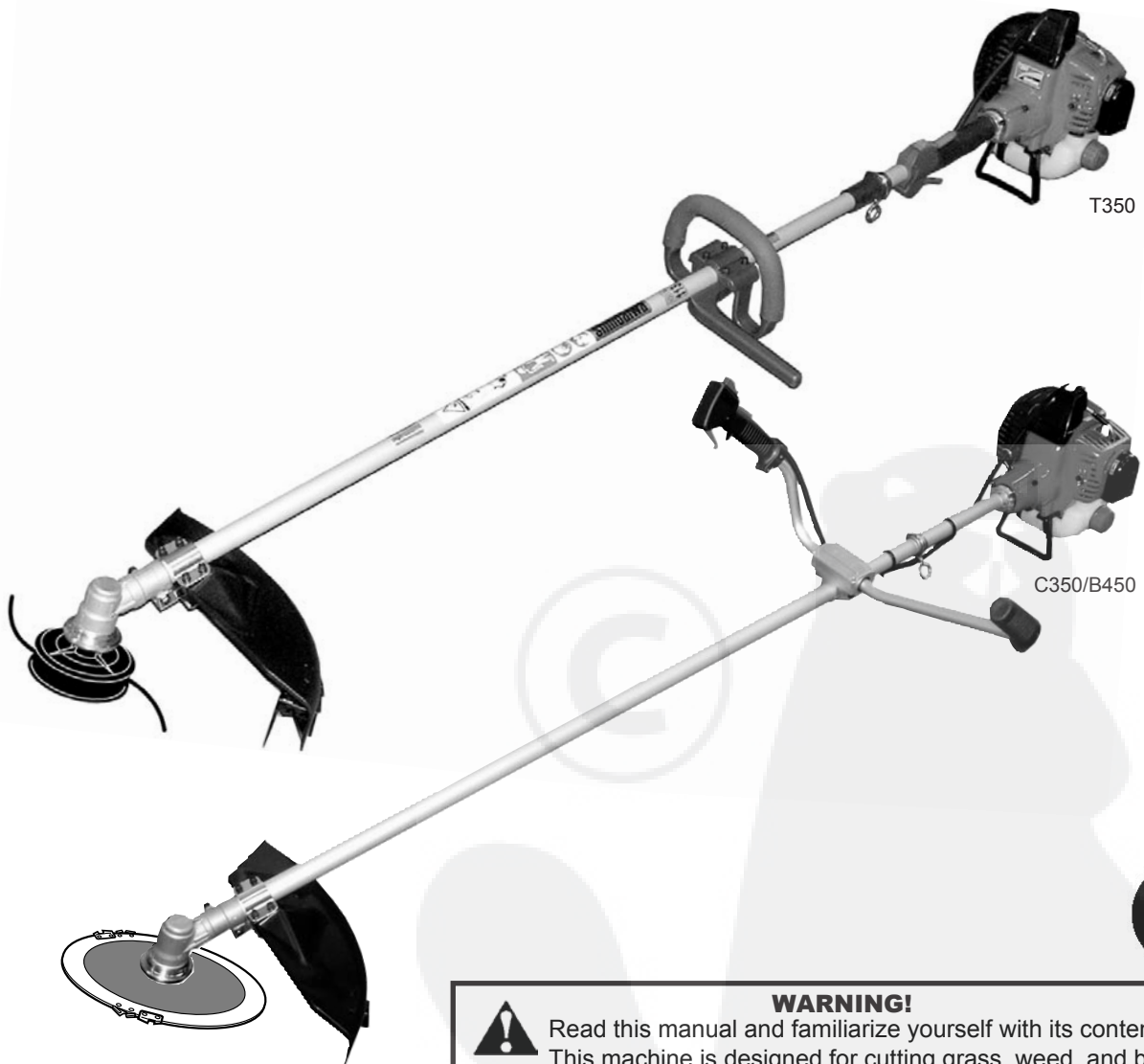

T350

C350/B450



WARNING!

Read this manual and familiarize yourself with its contents.
This machine is designed for cutting grass, weed, and bushes. Do not use this machine for other purposes.
Minimize the risk of injury to yourself and others.
Do not operate or service this machine unless you clearly understand this manual.
Keep this manual at a particular place so that you can reread it whenever you have a question about its use.

shindaiwa

Introduction

Shindaiwa 350 and 450-series hand held power equipment has been designed and built to deliver superior performance and reliability without compromise to quality, comfort, safety or durability.

Shindaiwa's high-performance engines represent the leading edge of 2-cycle engine technology, delivering exceptionally high power with remarkably low displacement and weight. As an owner/operator, you'll soon discover for yourself why Shindaiwa is simply in a class by itself!

IMPORTANT!

The information contained in this owner's/operator's manual describes units available at the time of publication.

Shindaiwa Inc. reserves the right to make changes to products without prior notice, and without obligation to make alterations to units previously manufactured.

Contents

	Page
Attention Statements	2
General Safety Instructions	3
Safety Labels.....	5
Checking Unit Condition	5
Unit Description.....	6
Specifications.....	6
Assembly Procedure.....	7
Mixing Fuel	12
Starting the Engine.....	13
Stopping the Engine	14
Adjusting Engine Idle	14
Shoulder Strap/Harness	14
Operation	15
Using a Brush Cutter	
With a Trimmer Head	16
Maintenance	16
Long Term Storage.....	18
Blade Sharpening.....	18
Troubleshooting Guide	19
Declaration of Conformity.....	22

Attention Statements

Throughout this manual are special attention statements.



WARNING!

A statement preceded by the triangular attention symbol and the word "WARNING" contains information that should be acted upon to prevent serious bodily injury.

CAUTION!

A statement preceded by the word "CAUTION" contains information that should be acted upon to prevent mechanical damage.

IMPORTANT!

A statement preceded by the word "IMPORTANT" is one that possesses special significance.

NOTE:

A statement preceded by the word "NOTE" contains information that is handy to know and may make your job easier.

IMPORTANT!

The operational procedures described in this manual are intended to help you get the most from unit as well as to protect you and others from harm. These procedures are guidelines for safe operation under most conditions, and are not intended to replace any safety rules and/or laws that may be in force in your area. If you have questions regarding your Shindaiwa power tool, or if you do not understand something in this manual, your Shindaiwa dealer will be glad to assist you. You may also contact Shindaiwa, Inc. at the address printed on the back of this manual.

	Read and follow this operators manual. Failure to do so could result in serious injury.
	Wear head, eye, and hearing protection during the operation of this machine.
	Wear non-slip gloves, long trousers and non-skid boots during the operation of this machine.
	make sure no one is within 15 meters of an operating machine.
	Beware of thrown objects.
	The maximum speed of the cutting attachment shaft in min ⁻¹ .
	Sound Power Level (measured in accordance with 2000/14/EC)

General Safety Instructions

Work Safely

Trimmers and brushcutters operate at very high speeds and can do serious damage or injury if they are misused or abused. *Never allow a person without training or instruction to operate this unit!*



WARNING!

Never make unauthorized attachment installations.



WARNING!

Use Good Judgment

NEVER run the engine when transporting the unit.

NEVER run the engine indoors! Make sure there is always good ventilation. Fumes from engine exhaust can cause serious injury or death.

ALWAYS use the proper cutting tool for the job.

ALWAYS stop the unit immediately if it suddenly begins to vibrate or shake. Inspect for broken, missing or improperly installed parts or attachments.

NEVER extend trimming line beyond the length specified for your unit.

ALWAYS keep the unit as clean as practical. Keep it free of loose vegetation, mud, etc.

ALWAYS hold the unit firmly with both hands when cutting or trimming, and maintain control at all times.

ALWAYS keep the handles clean.

ALWAYS disconnect the spark plug wire before performing any maintenance work.

ALWAYS, if a saw blade should bind fast in a cut, shut off the engine immediately. Push the branch or tree to ease the bind and free the blade.

Stay Alert

You must be physically and mentally fit to operate this unit safely.



WARNING!

Never operate power equipment of any kind if you are tired or if you are under the influence of alcohol, drugs, medication or any other substance that could affect your ability or judgement.

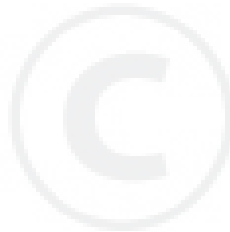

The Properly Equipped Operator

Wear hearing protection devices and a broad-brimmed hat or helmet.

Always wear eye protection such as goggles or safety glasses to shield against thrown objects.

Wear close-fitting clothing to protect legs and arms. Gloves offer added protection and are strongly recommended. Do not wear clothing or jewelry that could get caught in machinery or underbrush. Secure long hair so that it is above shoulder level. NEVER wear shorts!

Always wear a harness when operating a unit equipped with a blade.

Always operate with both hands firmly gripping the unit.

When operating with a blade, make sure the handle is positioned to provide you with maximum protection from contacting the blade.

Keep a proper footing and do not overreach. Maintain your balance at all times during operation.

Always make sure the appropriate cutting attachment shield is correctly installed and in good condition.

Wear appropriate footwear (non-skid boots or shoes): do not wear open-toed shoes or sandals. Never work barefooted!

Keep away from the rotating trimmer line or blade at all times, and never lift a moving attachment above waist-high.

Be Aware of the Working Environment

Avoid long-term operation in very hot or very cold weather.

Reduce the risk of bystanders being struck by flying debris. Make sure no one is within 15 meters — that's about 16 paces — of an operating attachment.

If contact is made with a hard object, stop the engine and inspect the cutting attachment for damage.

Make sure bystanders or observers outside the 15 meter "danger zone" wear eye protection.

15 METERS

Be extremely careful of slippery terrain, especially during rainy weather.

Always make sure the appropriate cutting attachment shield is correctly installed.

Beware of a coasting blade when brushcutting or edging. A coasting blade can injure while it continues to spin after the throttle trigger is released or after the engine is stopped.

Be constantly alert for objects and debris that could be thrown either from the rotating cutting attachment or bounced from a hard surface.

ALWAYS clear your work area of trash or hidden debris that could be thrown back at you or toward a bystander. When operating in rocky terrain or near electric wires or fences, use extreme caution to avoid contacting such items with the cutting attachment.

Safety Labels



IMPORTANT!

Safety and Operation Information Labels: Make sure all information labels are undamaged and readable. Immediately replace damaged or missing information labels. New labels are available from your local authorized Shindaiwa dealer.

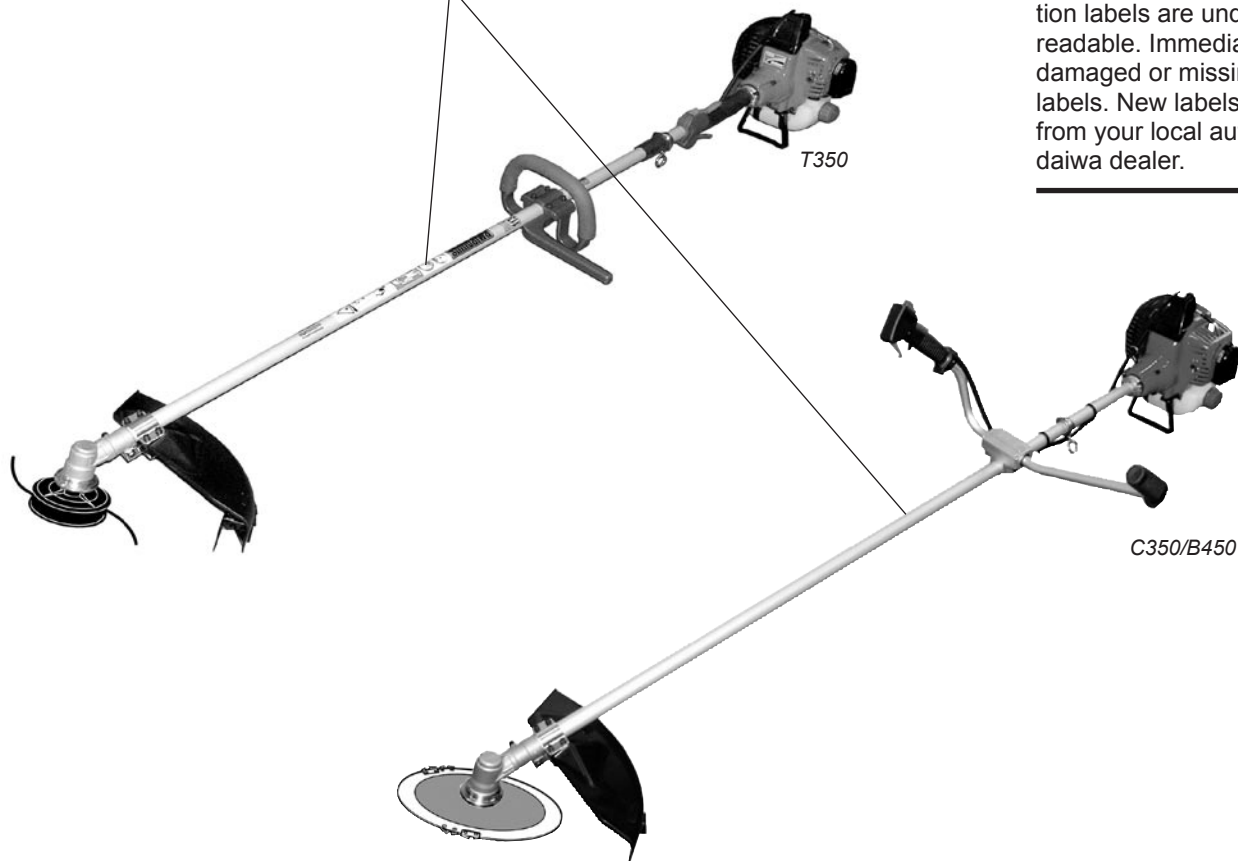

Checking Unit Condition



WARNING!

A cutting attachment shield or other protective device is no guarantee of protection against ricochet. **YOU MUST ALWAYS GUARD AGAINST FLYING DEBRIS!**

Use only authorized Shindaiwa parts and accessories with your Shindaiwa trimmer or brushcutter. Do not make modifications to this unit without the written approval of Shindaiwa, Inc.

NEVER operate the unit with the cutting attachment shield or other protective devices (harness, ignition switch, blade retention clip, etc.) removed!

ALWAYS make sure the cutting attachment is properly installed and firmly tightened before operation.

NEVER use a cracked or warped cutting attachment: If a properly installed attachment vibrates, replace the attachment with a new one and re-check.

ALWAYS stop the engine immediately and check for damage if you strike a foreign object or if the unit becomes tangled. Do not operate with broken or damaged equipment.

NEVER allow the engine to run at high RPM without a load. Doing so could damage the engine.

NEVER operate a unit with worn or damaged fasteners or attachment holders.

NEVER cut with a dull blade. Doing so will increase the risk of blade thrust and may also cause equipment damage.

Unit Description

Using the accompanying illustrations as a guide, familiarize yourself with this unit and its various components. Understanding the product helps ensure top performance, long service life, and safer operation.



WARNING!

Do not make unauthorized modifications or alterations to any of these units or their components.

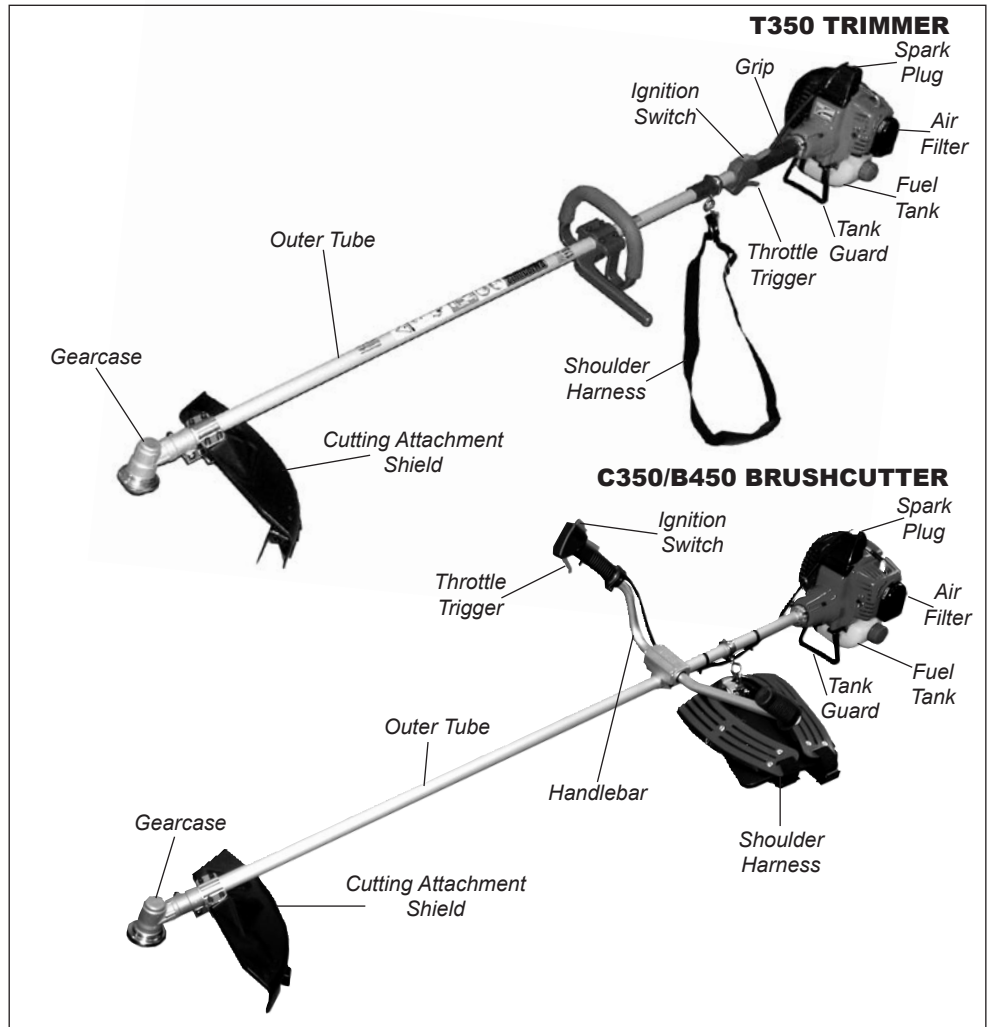

Specifications

Model Name.....	T350/EC1	C350/EC1	B450/EC1
Engine Model.....	S350EC1	S350EC1	S450EC1
Engine Type.....	2-cycle, vertical cylinder, air cooled		
Displacement	33.6 cm ³	33.6 cm ³	41.5 cm ³
Bore and Stroke.....	36 x 33 mm	36 x 33 mm	40 x 33 mm
Maximum Power Output.....	1.3 kW	1.3 kW	1.6 kW
Engine Speed at Idling	2,750 min ⁻¹	2,750 min ⁻¹	2,750 min ⁻¹
Maximum Engine Speed	11,500 min ⁻¹	11,500 min ⁻¹	11,500 min ⁻¹
Engine Speed at Maximum Power Output.....	7,500 min ⁻¹	7,500 min ⁻¹	7,500 min ⁻¹
Dry Weight (Without cutting attachment and guard.).....	7.0 kg	7.7 kg	7.7 kg
Dimensions (L x H x H) mm	1795x365x320	1795x565x470	1795x565x475
Fuel Tank Capacity.....	1000 cm ³		
Fuel/Oil Ratio.....	50:1		
Carburetor Type	TK, DPV11W, Diaphragm		
Ignition.....	Fully electronic, transistor controlled		
Spark Plug.....	NGK BMR6A		
Air Cleaner Type	Semi-wet		
Starting Method.....	Recoil Starter		
Stopping Method	Slide Switch		
Handle Type	Loop Handle	Bicycle Handlebar	
Sound Pressure Level* (average data between at Idling and at Racing) Note 1	93 dB (A)	90 dB (A)	92 dB (A)
Sound Power Level** (average data between at Idling and at Racing) Note 1	105 dB (A)	106 dB (A)	107 dB (A)
Vibration Level*** Note 1.....	Idling (Left/Right)	2.6/2.1 m/s ²	3.4/2.2 m/s ²
	Racing (Left/Right)	3.0/2.3 m/s ²	4.7/3.5 m/s ²
Sound Pressure Level* (average data between at Idling and at WOT) Note 2	98 dB (A)	98 dB (A)	96 dB (A)
Sound Power Level** (average data between at Idling and at WOT) Note 2	110 dB (A)	110 dB (A)	112 dB (A)
Vibration Level*** Note 2.....	Idling (Left/Right)	1.6/1.6 m/s ²	1.5/1.3 m/s ²
	WOT (Left/Right)	2.3/1.3 m/s ²	2.8/4.2 m/s ²
	5.3/6.8 m/s ²	3.4/3.6 m/s ²	

* Sound Pressure Level: In accordance with EN ISO 11806 and ISO 7917

** Sound Power Level In accordance with EN ISO 11806 and ISO 10884

*** Vibration Level: In accordance with EN ISO 11806 and ISO 7916

Note 1: 8-tooth blade equipped.

Note 2: Trimmer head equipped.

Assembly Procedure

Prior to Assembly

Before assembling, make sure you have all the components required for a complete unit:

- Engine assembly
- Outer tube assembly
- Cutting attachment shield
- Cutting attachment
- Handlebar
- Kit containing cutting attachment shield mounting bracket and hardware, operator's handle mounting bracket and hardware, gearcase tool holder, this manual and tool kit for routine maintenance. Tool kits vary by model and may include a hex wrench, spanner and a combination spark plug wrench/screwdriver.

Carefully inspect all components for damage.

IMPORTANT!

The terms "left", "left-hand", and "LH"; "right", "right-hand", and "RH"; "front" and "rear" refer to directions as viewed by the operator during normal operation.

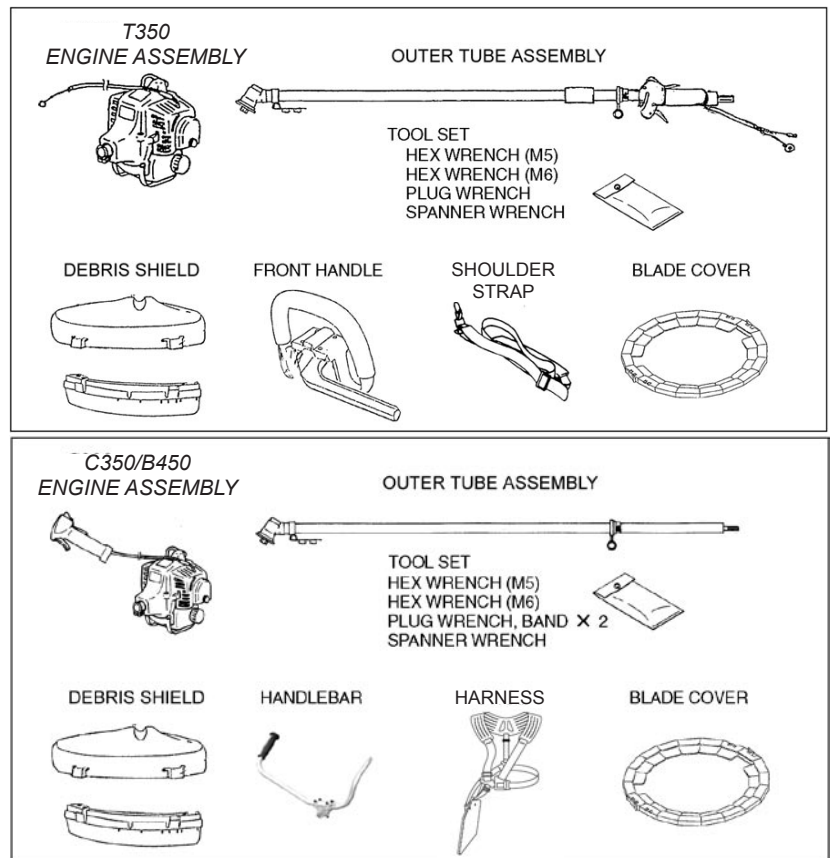

Assembling the Outer Tube

T350

(1) Loosen the 2 joint bolts fully.

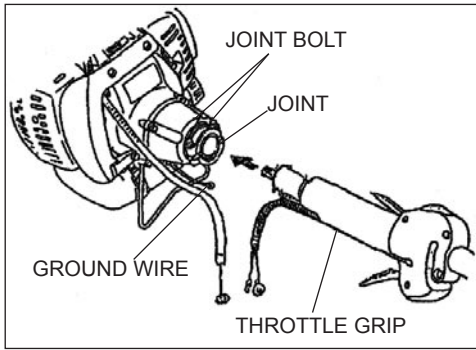

(2) Slip the outer tube into the joint until the tube bottoms. The outer tube or gearcase shaft may have to be rotated slightly for the splines on the mainshaft to fully engage to the engine.

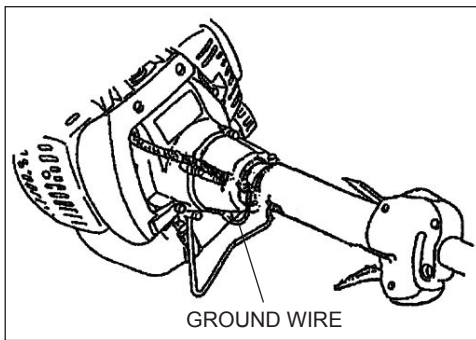

- (3) Attach the ground wire to the joint bolt.
- (4) Tighten the 2 joint bolts securely.
- (5) Loosen the screw which tightens the throttle lever to the outer tube. Shift the throttle lever toward the blade.
- (6) Put the throttle cable into the tube. Push throttle cable through hole in rear grip.
- (7) Set the throttle cable onto the throttle lever. Use the wrench so that the wire edge goes into the slot of the throttle lever securely.

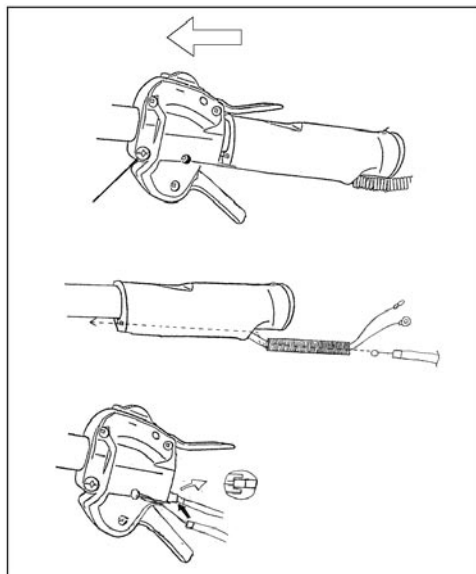

NOTE:

Make sure that the throttle cable is built into the cable guide of the throttle lever.

- (8) Shift the throttle lever back to original position, pulling the ground wire and throttle cable and tighten the screw securely.
- (9) Remove the bolt tightening the cylinder cover.
- (10) Put the bolt through the hole of the ground wire terminal and tighten the bolt.

Assembly of the Outer Tube C350/B450

- (1) Loosen the 2 joint bolts fully and slip the outer tube into the joint until the tube bottoms (up to the insert label). The outer tube or gearcase shaft may have to be rotated slightly for the splines on the mainshaft to fully engage the engine.
- (2) Attach the ground wire to the joint bolt.
- (3) Tighten the 2 joint bolts securely.

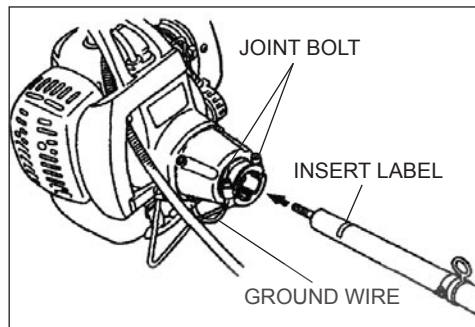

- (4) Loosen the stopper bolt of the throttle grip. Remove the stopper bolt and nut.
- (5) Fully loosen the clamp bolt of the throttle grip.

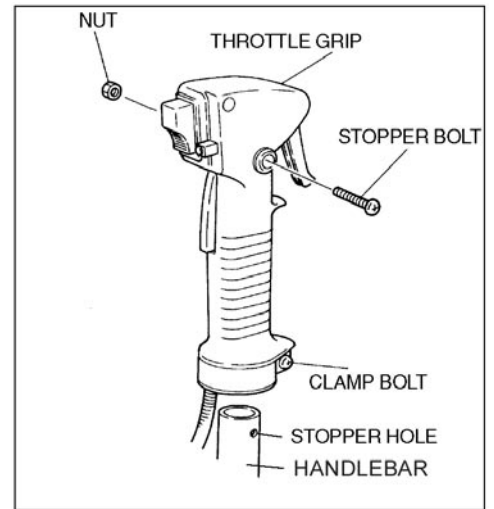

- (6) Slip the right-side handlebar into the throttle grip. Locate the throttle grip so that the stopper bolt can pass through the stopper hole. Securely tighten the stopper bolt and nut.
- (7) Securely tighten the clamp bolt.

Assembly of the Handle T350



WARNING!

NEVER operate this machine without the front handle. Operating without the front handle may result in serious injury.

NOTE:

Tighten four bolts diagonally to properly secure the handle.

NOTE:

Adjust the handle at the best position for operator comfort.

(1) Put four square nuts in the recesses on the underside of the barrier.

(2) Fit the handle and barrier over the outer tube and tighten four bolts in a crisscross fashion.

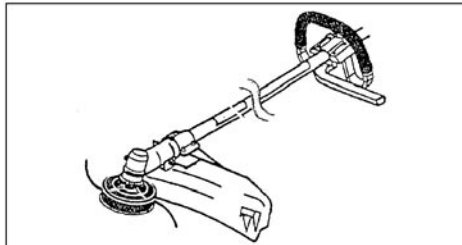
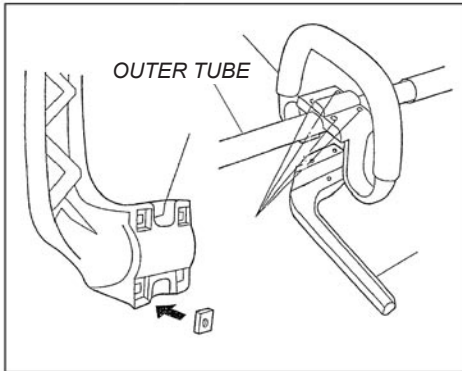

Assembly of the Handle C350/B450

(1) Loosen the two bolts of the lower cap and remove the lower cap.

(2) Position the handle bracket against the handle label located on the outer tube.

(3) Attach the lower cap with the two bolts and tighten the bolts. Make sure the front handle is in position per the illustration.

(4) Secure the cable to the outer pipe with the two bands as the illustration shows. The two bands are in the tool bag.

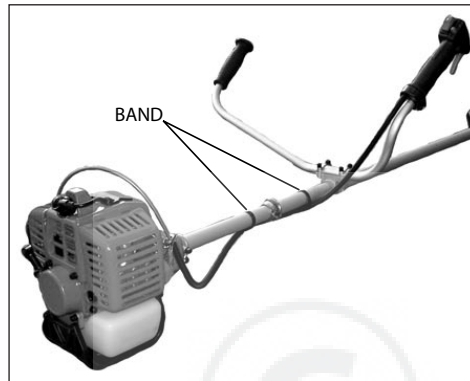
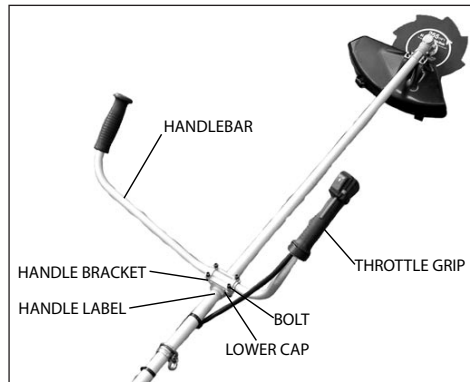

Throttle Cable Adjustment

(1) Pull the throttle trigger gently, and check for free-play of approximately 5mm.

(2) If free-play is out of specifications:

(a) Slide the cable cap toward the muffler side until the adjusting nut and the lock nut appear.

(b) Loosen the lock nut slightly.

(c) Turn the adjusting nut so that free-play is about 5mm.

(d) Then, tighten the lock nut.

(e) Slide the cable cap back.

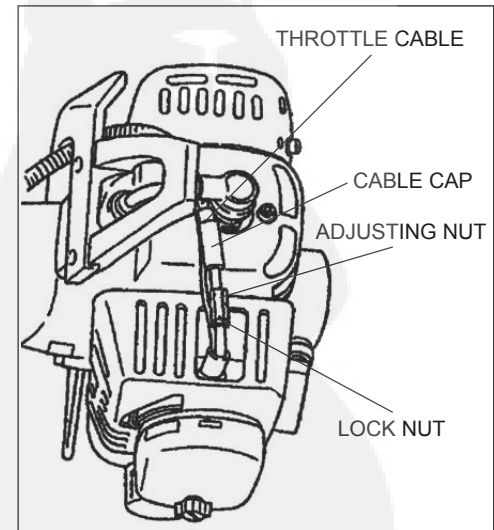
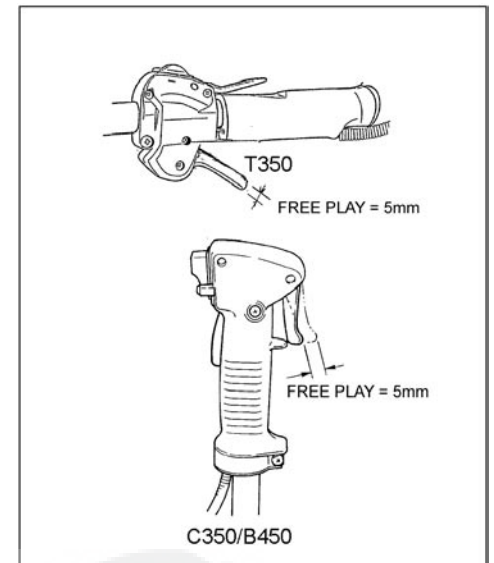

Cutting Attachment Shield Assembly



WARNING!

NEVER operate this machine without the cutting attachment shield. Operating without the cutting attachment shield may result in serious injury.

(A) Cutting Attachment Shield

(1) Insert the cutting attachment shield between the outer tube and the lower clamp. Loosen the nut and bolt which are tightening the lower clamp if the cutting attachment shield does not fit with the lower clamp.

NOTE:

It may be necessary to loosen the lower clamp bolt so that the shield will fit between the tube and clamp.

(2) Fit the two spacers (T350 only) and the upper clamp over the outer pipe and tighten with four bolts.

NOTE:

Tighten four bolts a crisscross fashion.

(3) Tighten the lower clamp bolt and nut securely.



WARNING!

Carefully inspect the cutting attachment shield assembly to make sure it is tightened securely and does not wobble.

(B) Shield Extension (when trimmer head is in use)

(1) Attach the shield extension to the cutting attachment shield.

NOTE:

Make sure the shield extension is completely hooked at the hook receiver.

CAUTION!

The line cutter is attached to the shield extension and must be used when operating with a trimmer head.

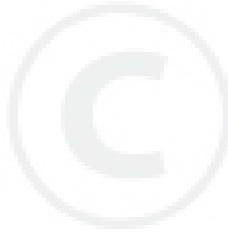
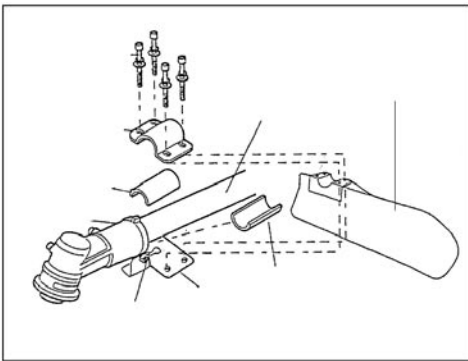
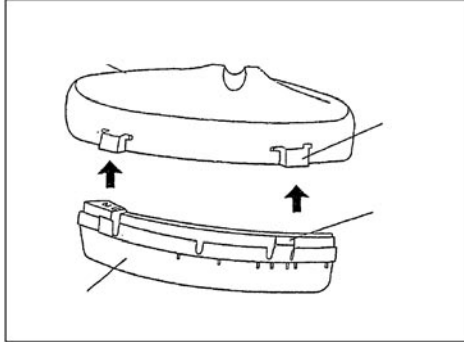

Installing a Blade

(1) Make sure the switch is off and the engine is stopped.

(2) Wear gloves to protect your hands.

(3) Turn the unit over so the saw holder flange extending from the gear case is facing up.

(4) Using the small end of the plug wrench, loosen the bolt (turn clockwise) and remove the bolt, bolt guard, and holder B.

(5) Slide the safety clip as shown in the illustration.

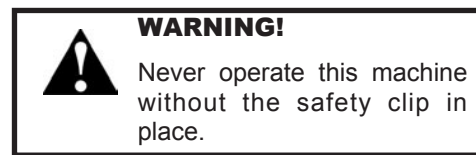
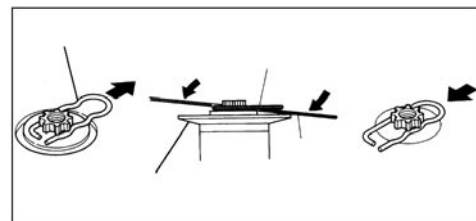
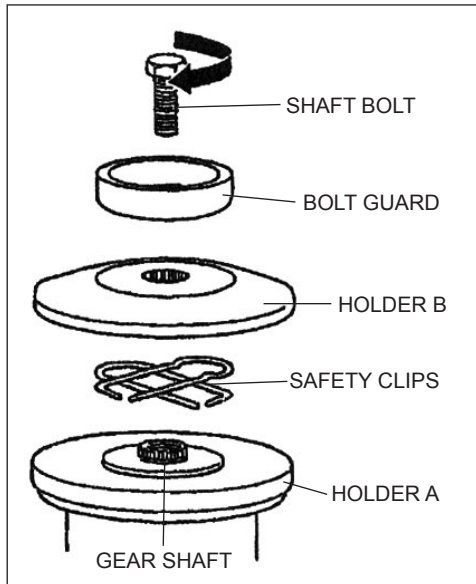

(6) Fit the blade over the safety clip onto holder A. Then, slide the safety clip back to its original position.

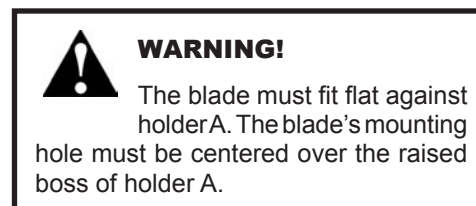

(7) Put holder B and bolt guard back and at this time only finger tighten the bolt.

Make sure holder B is flat against the blade and the recess in holder B must face the blade and completely cover the safety clip.

(8) Rotate holder A until the hole in its skirt aligns with the hole in the gear case. Insert the hex wrench through both holes (to prevent the shaft from turning).

(9) Holding the hex wrench and blade with one hand, tighten the bolt (turn counterclockwise) securely using the hex socket end of the plug wrench.

(10) Remove the hex wrench.

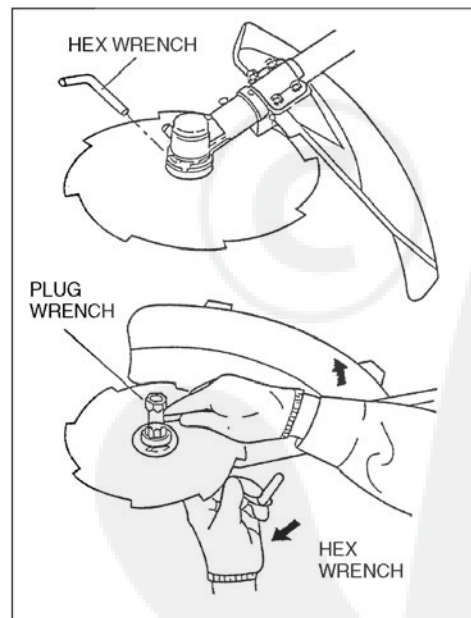
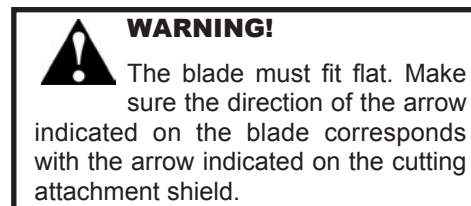
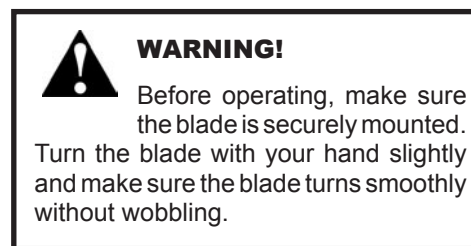

Mixing Fuel



WARNING!

Minimize the risk of fire, burns, and personal injury!

- **STOP** engine before refueling.
- **ALWAYS** allow the engine to cool before refueling
- **ALWAYS** open the fuel cap slowly to allow any pressure build-up in the tank to release fuel vapor slowly.
- **ALWAYS** transport and store fuels in an approved container.
- Avoid overfilling and wipe-up all spilled fuel. Move the engine at least 3 meters from the fueling point, storage area, and other readily flammable materials before restarting.
- **ALWAYS** inspect the unit for fuel leaks before each use. During each refill, make sure there are no fuel leaks around the fuel cap and/or tank. If a fuel leak is evident, stop using the unit immediately. Fuel leaks must be repaired before using the unit.
- **NEVER** smoke or light any fires near the engine or fuel source.
- **NEVER** place any flammable material near the engine or muffler.
- **NEVER** operate the engine without the muffler in good working condition.
- **ALWAYS** move the unit to a place well away from a fuel storage area or other readily flammable materials before starting the engine.

CAUTION!

This engine is designed to operate on a 50:1 mixture consisting of unleaded gasoline and a premium 2-cycle mixing oil only. Use of Non-approved mixing oils can lead to excessive maintenance costs and/or engine damage.

CAUTION!

Some gasolines contain alcohol as an oxygenate! Oxygenated fuels may cause increased operating temperatures. Under certain conditions, alcohol-based fuels may also reduce the lubricating qualities of some mixing oils. Never use any fuel containing more than 10% alcohol by volume! Generic oils and some outboard motor oils may not be intended for use in high-performance air cooled 2-cycle engines, and should never be used in your Shindaiwa engine!

Filling The Fuel Tank

IMPORTANT!

Mix only enough fuel for your immediate needs! If fuel must be stored longer than 30-days, it should first be treated with a stabilizer such as StaBil™ or equivalent product!

- Use only fresh, clean unleaded gasoline with a pump octane rating of 87 or higher.
- Mixing fuel with a Premium 2-cycle mixing oil designed for use with high-performance 2-cycle air-cooled engines.
- Refer to the following examples of 50:1 fuel to oil mix quantities:

Gasoline liters	2-cycle mixing oil milliliters
2.5 l	50 ml
5 l	100 ml
10 l	200 ml
20 l	400 ml

CAUTION!

Never attempt to mix fuel in the unit's fuel tank. Always mix all fuels in a clean approved container.

1. Place the unit on a flat, level surface, and wipe any debris from around the fuel cap.
2. Remove the fuel cap.
3. Fill the tank with clean, fresh fuel.
4. Replace the cap, and wipe away any spilled fuel before starting the engine.



Starting the Engine



WARNING!

MAKE SURE THE BLADE IS WELL CLEAR OF ANY INTERFERENCE. Before starting the engine, place unit on clear, level surface. Make sure you have good secure footing and always keep a firm grip on the machine. THE CUTTING ATTACHMENT MAY ROTATE WHEN THE ENGINE STARTS.



WARNING!

Move at least three meters away from the fuel site before starting the engine.



WARNING!

Never operate the engine without the cutting attachment installed.

(b) Prime the engine by repeatedly depressing the carburetor primer bulb until fuel can be seen flowing through the transparent overflow return tube:

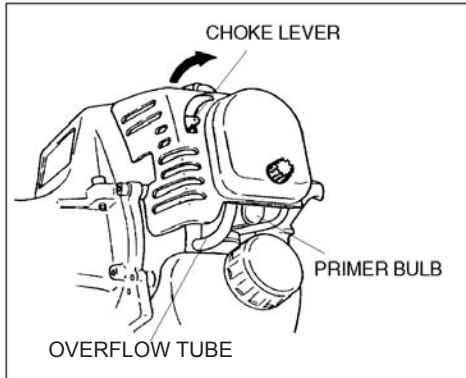

(c) Push the choke lever upward (“I” closed “ position). (Cold engine.)

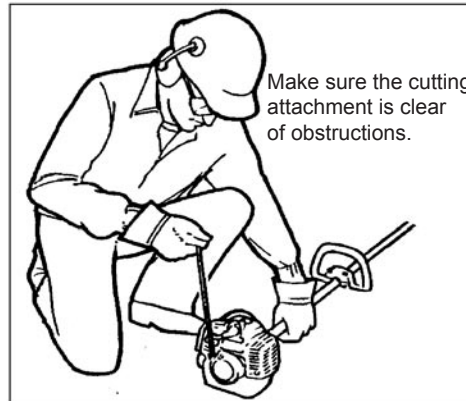

(d) Depressing the lock lever, pull the throttle lever fully and depress the throttle lock button. While depressing the throttle lock button, release the throttle lever and the lock lever. Now the throttle stays at high idle (starting speed).

(e) While firmly holding the outer tube with one hand, pull the recoil starter handle upward with your other hand. Pull slowly at first until you feel the starter engage, then pull quickly to start the engine. Do not pull the starter rope to the end of its travel.

CAUTION!

Pulling the starter rope to the end of its travel may damage the starter mechanism.

IMPORTANT!

Repeated cranking of the engine with the choke CLOSED (“I”) will lead to engine flooding. If the engine fails to start after several attempts, move the choke lever to the OPEN position and continue cranking.

(f) When the engine first fires, gradually return the choke to OPEN (“III”) position if you have not already done so.

- If the engine stops before the choke is fully open, restart with the choke closed.
- If the engine stops after the initial firing, restart with choke closed.

(g) When the engine starts and is running, set the engine to idle by tapping the throttle lever to release the throttle lock.



WARNING!

Never start the engine from the operating position.

Starting a Cold Engine and/or Restarting After Refueling.

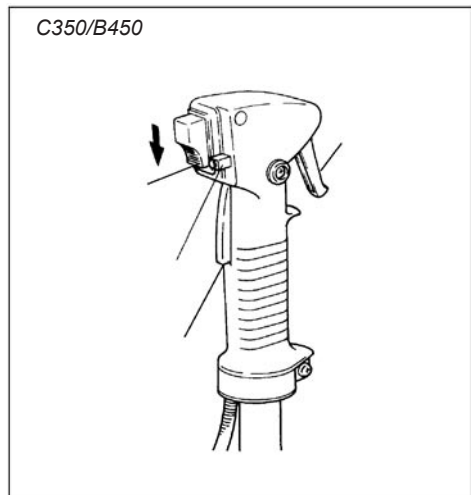
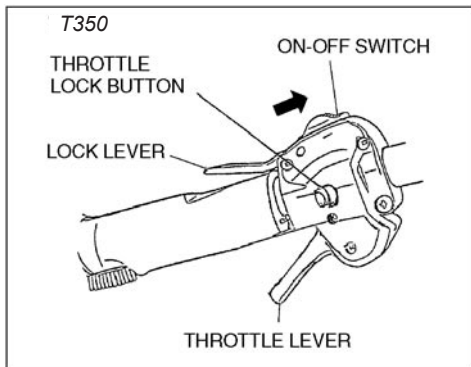

(a) Slide the ON-OFF switch to the “I” position.

Starting a Warm Engine

Starting a warm engine involves all of the steps of starting a cold engine. EXCEPT:

- The choke should be in the OPEN position.
- If the engine does not start, follow the cold engine starting procedure.

When the engine starts:

- After the engine starts, disengage the throttle lock and allow the engine to warm-up at idle for 2 or 3 minutes before operating the machine.
- After the engine is warm, pick up the machine and clip-on the strap.
- Advancing the throttle makes the cutting attachment rotate faster; releasing the throttle makes the attachment stop running. If the cutting attachment continues to rotate, carburetor idle speed should be adjusted. (See next page.)

Stopping the Engine

Idle the engine briefly before stopping, then slide the ON-OFF switch to the "O" (for STOP) position.



WARNING!

The cutting attachment continues rotating for a while after the switch is turned off.

C350/B450

ON-OFF SWITCH

T350

ON-OFF SWITCH

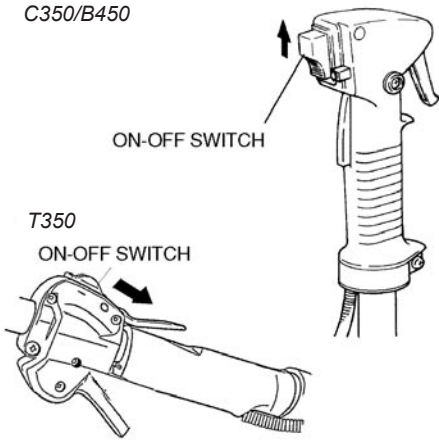

Engine Idle Adjustment

The engine must return to idle speed whenever the throttle lever is released. Idle speed is adjustable, and must be set low enough to permit the engine clutch to disengage the cutting attachment when the throttle is released.



WARNING!

The cutting attachment must NEVER rotate at engine idle! If the idle speed can not be adjusted by the procedure described here, have the unit inspected at an authorized Shindaiwa dealer.

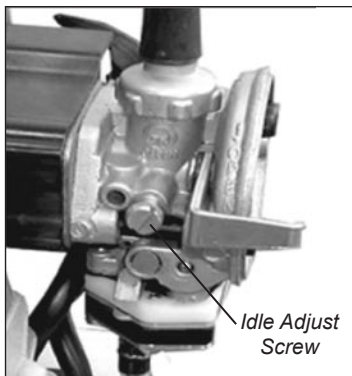

Idle Adjust Screw

(1) Place the unit on the ground, then start the engine and allow it to idle for 2-3 minutes until warm.

(2) If the attachment rotates when the engine is at idle, reduce the idle speed by turning the idle adjustment screw counterclockwise.

(3) If a tachometer is available, the engine idle speed should be adjusted to 2,750 min⁻¹ (rpm)

NOTE:

Carburetor fuel mixture adjustments are preset at the factory on units with emission control systems and cannot be serviced in the field.

Shoulder Strap/Harness

To Wear the Strap

- (1) Attach the strap hook to the hanger on the outer pipe.
- (2) Wear the strap so that the hook stays at your right side.
- (3) Adjust the length of the strap so that you can hold and operate the machine comfortably.
- (4) Make sure the hip pad stays between your hip and outer pipe. (B450 ONLY)

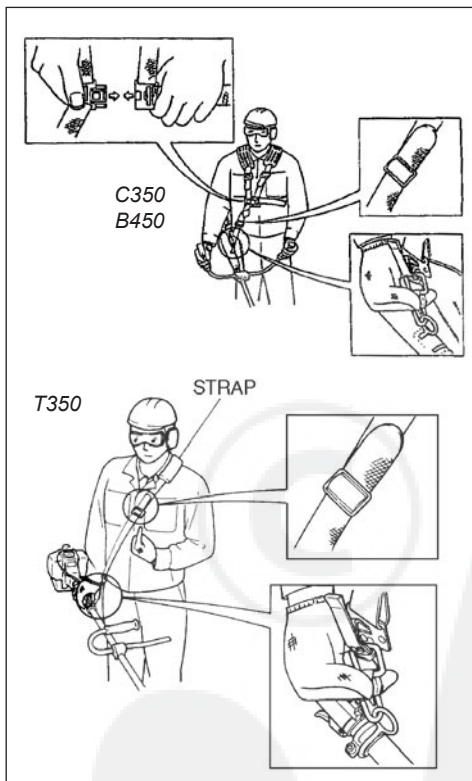

Emergency Release

In case of emergency, firmly pull the white tab at the hook. The machine will release from the strap.

C350/B450

T350

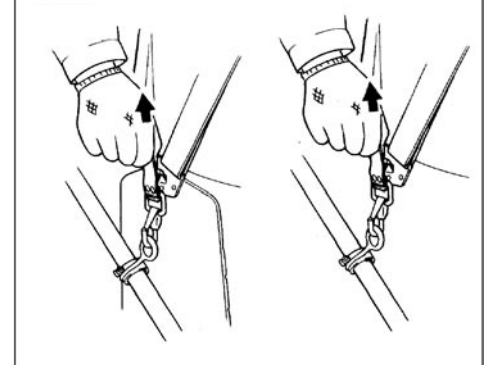

IMPORTANT!

Adjust the shoulder strap so the shoulder pad rests comfortably on the off-side shoulder and the cutting path of the cutting attachments is parallel to the ground. Make sure all hooks and adjustment devices are secure.



WARNING!

Always wear a harness when operating this unit with a blade.

NOTE:

Using a harness with a brushcutter allows you to maintain proper control of the unit and reduces fatigue during extended operation.

Double Shoulder Harness

Adjust the double shoulder harness straps so the shoulder pads rest comfortably on the offside of the shoulder and the cutting path of the blade is parallel to the ground. Make sure all hooks and adjusting devices are secure.

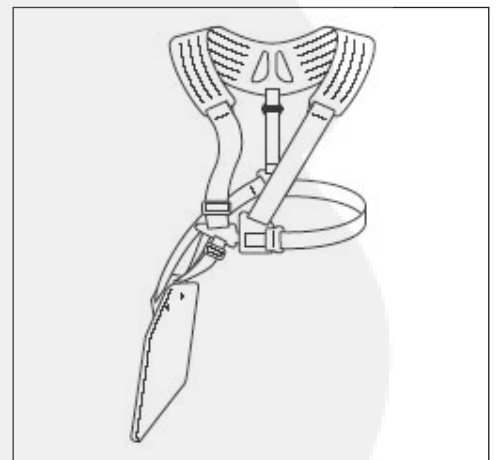

Operation

Using A Blade

- (1) After starting the engine, pull the throttle lever gradually. The engine speed increases and the blade will start rotating.
- (2) When the throttle lever is released, the engine goes back to idle speed automatically.
- (3) Operate the machine at full throttle while cutting. Best fuel efficiency is obtained by releasing the throttle when swinging back after cut.
- (4) The blade rotates counterclockwise. For best performance and to minimize being stuck by debris, move the blade from right to left while advancing on your work.



WARNING!

Position the blade so cuts are made between blade's 8 o'clock and 10 o'clock positions (as viewed from above). DO NOT cut between the 11 o'clock and 5 o'clock positions.



WARNING!

"BLADE THRUST" is a sudden sideway or backward motion of the machine. Such motion may occur when the blade jams or catches on an object such as a sapling tree or tree stump. BE CONSTANTLY ALERT FOR BLADE THRUST AND GUARD AGAINST ITS EFFECTS.

CAUTION!

DO NOT use 2-tooth blades with this machine.

CAUTION!

To prevent possible engine damage, do not allow the machine to run at high speeds without a load. Avoid operating the engine at low speeds. Doing so can lead to rapid clutch wear. In addition, slow-speed operation tends to cause grass and debris to wrap around the cutting attachment.

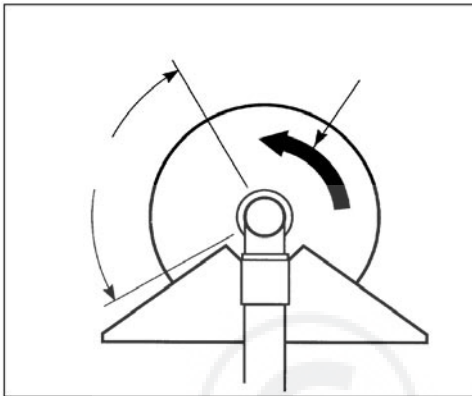

WARNING!

NEVER strike or slam the spinning blade against the wood.



WARNING!

When transporting, make sure the engine is not running and blade is covered with blade cover.

Recommended Cutting Attachments

Make sure to use the following recommended Shindaiwa cutting attachment with this machine.

Blades

PART NUMBER 60903-98310
8-TOOTH BLADE
INNER BORE: 25.4mm
DIAMETER: 255.0mm
THICKNESS: 2.0mm



PART NUMBER 72430-92142
3-TOOTH BLADE
INNER BORE: 25.4mm
DIAMETER: 255.0mm
THICKNESS: 2.2mm



PART NUMBER 60903-98320
4-TOOTH BLADE
INNER BORE: 25.4mm
DIAMETER: 255.0mm
THICKNESS: 2.0mm

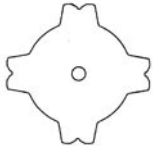

Trimmer Heads

(A) C350

PART NUMBER 78820-16000
TAP & FEED TRIMMER HEAD
BOLT DIAMETER: 10mm
THREAD: LEFT, 1.25mm PITCH



(B) B450

PART NUMBER 78820-14000
SEMI-AUTOMATIC TRIMMER HEAD
BOLT DIAMETER: 10mm
THREAD: LEFT, 1.25mm PITCH



(C) T350

PART NUMBER 78820-15000
TAP & FEED TRIMMER HEAD
BOLT DIAMETER: 8mm
THREAD: LEFT, 1.25mm PITCH



Using a Brushcutter With a Trimmer Head

You may install one of several types of Shin-daiwa trimmer heads on your TC350/B450 trimmer or brushcutter, each with features for specific applications and/or operational requirements.

For proper operation, always refer to the instructions accompanying the trimmer head being used. Available trimmer head styles include:

- **Semi-automatic.** Trimmer line is indexed when the operator taps the trimmer head on the ground during operation.
- **Manual.** The operator indexes line manually with the grass trimmer stopped.
- **Fixed.** The operator must stop the unit and add new lengths of trimmer line manually.
- **Flail.** This device, designed for clearing weeds and light brush, features three nylon blades attached to the head by pivots.

CAUTION!

Do not push the rotating line into trees, wire fences or any material that could tangle or break line ends.

Engine Operating Speeds

Operate at full throttle while cutting grass.

CAUTION!

Operation at low rpm can lead to premature clutch failure.

Trimming and Mowing Grass

Hold the grass trimmer so the trimmer head is angled slightly into the area to be cut. To ensure maximum trimmer-line service life, cut only with the tip of the trimmer line. Cut grass by swinging the unit's trimmer head from left to right. Keep the trimmer head horizontal.

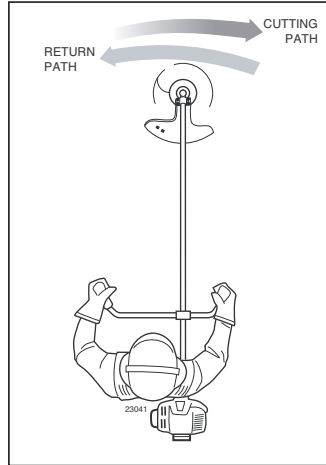

Edging

Tilt the handle about 100° to the left (from horizontal) and move forward, holding the trimmer or brushcutter vertically as shown.



Maintenance



WARNING!

Before performing any maintenance, repair, or cleaning work on the machine, make sure the engine and cutting attachment are completely stopped. Disconnect the spark plug wire before performing service or maintenance work.



WARNING!

Never repair a damaged blade by welding, straightening, or by modifying its shape. An altered blade may break during operation, resulting in serious personal injury.

Daily Maintenance

Prior to each work day, perform the following:

- Remove the dirt and debris from the engine, check the cooling fins and air cleaner for clogging, and clean them as necessary.
- Carefully remove any accumulations of dirt or debris from the muffler and fuel tank. Dirt buildup in these areas can lead to engine overheating, fire, or premature wear.
- Check for loose or missing screws or components. Make sure the cutting attachment is securely fastened.
- Check the machine for leaking fuel or grease.

10 Hour Maintenance

Remove the air cleaner element from the carburetor and clean it thoroughly with soap and water. Squeeze out excess, let dry and reassemble the element.

CAUTION!

Do not operate the machine if the air cleaner or element is damaged, or if the element is water-soaked.

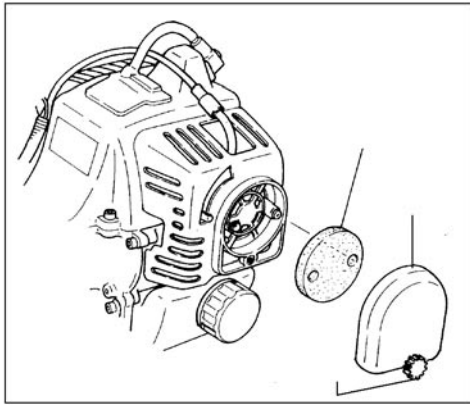

10/15 Hour Maintenance

Remove and clean the spark plug. Adjust the spark plug electrode gap to 0.6 - 0.7mm. If the plug must be replaced, use only NGK BMR6A.

CAUTION!

Before removing the spark plug, clean the area around the plug to prevent dirt and dust from getting into the engine's internal parts.

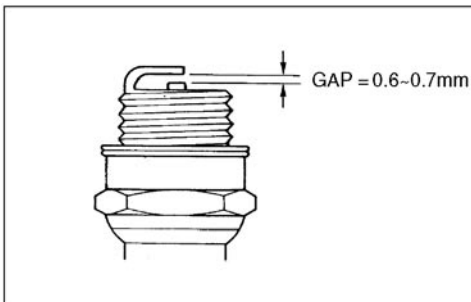

50 Hour Maintenance

Cleaning

Remove and clean the cylinder cover and clean grass and dirt from the cylinder fins.

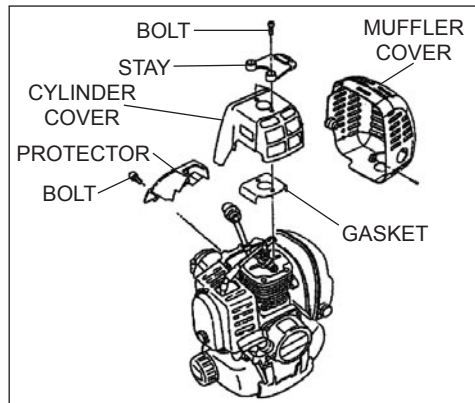

Remove the cutting attachment and the gear shaft collar, and press new grease into the gear case until the old grease has been pushed out. Use only lithium base grease (such as Shindaiwa Gear Case Lubricant).

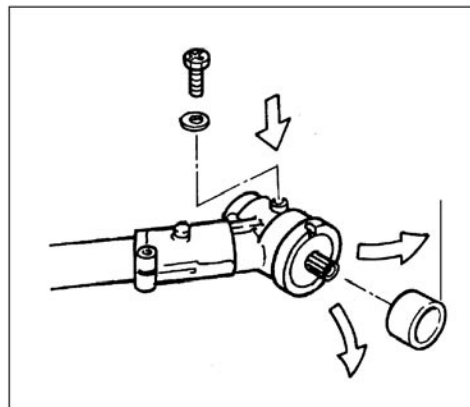

Fuel Filter Maintenance

Use a hooked wire to extract the fuel filter from inside the fuel tank. Remove and replace the filter element. Before reinstalling the filter, inspect the condition of the fuel line. If damage or deterioration are noted, the unit should be removed from service until you can consult with an authorized servicing dealer.

CAUTION!

Make sure you do not pierce the fuel line with the end of the hooked wire. The line is delicate and can be damaged easily.

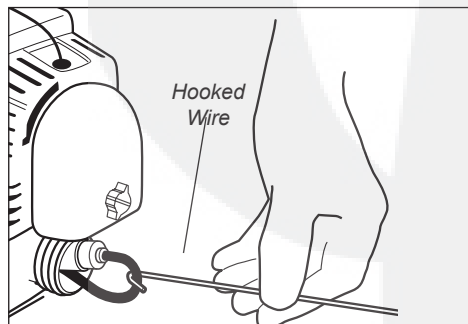

Muffler Maintenance

(350 only)

Hard starting or a gradual loss of performance can be caused by carbon deposits lodged in the muffler's spark arrester screen.

In such cases, performance can usually be restored by removing the spark arrester screen and giving it a thorough cleaning with a stiff bristle brush.

If carbon deposits are severe or if no performance improvement is noted, your unit should be returned to your Shindaiwa dealer for inspection.

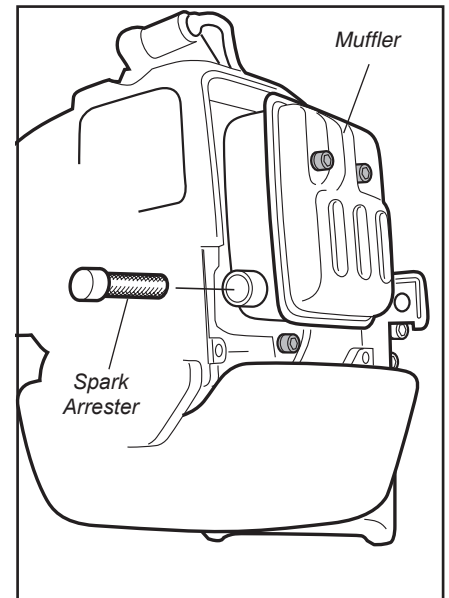

WARNING!

Never operate this unit with a damaged or missing muffler or spark arrester! Operating with missing or damaged exhaust components is a fire hazard and may also damage your hearing.

Long Term Storage

Whenever the unit will not be used for 30 days or longer, use the following procedures to prepare it for storage:

- Clean external parts thoroughly and apply a light coating of oil to all metal surfaces.
- Drain all the fuel from the fuel tank.

IMPORTANT!

All stored fuels should be stabilized with a fuel stabilizer such as STA-BIL™.

To remove the remaining fuel from the fuel lines and carburetor and with the fuel drained from the fuel tank.

1. Prime the primer bulb until no more fuel is passing through.
2. Start and run the engine until stops running.
3. Repeat steps 1 and 2 until the engine will no longer start.

CAUTION!

Gasoline stored in the carburetor for extended periods can cause hard starting, and could also lead to increased service and maintenance costs.

- Remove the spark plug and pour about 7 grams of 2-cycle mixing oil into the cylinder through the spark plug hole. Slowly pull the recoil starter 2 or 3 times so oil will evenly coat the interior of the engine. Reinstall the spark plug.
- Before storing the unit, repair or replace any worn or damaged parts.
- Remove the air cleaner element from the carburetor and clean it thoroughly with soap and water. Let dry and reassemble the element.
- Store the unit in a clean, dust-free area.

Blade Sharpening

With the file or a grinder, file a blade as follows.



WARNING!

Sharpen only the cutting teeth of a blade. DO NOT alter the contour of the blade in any way. In order to keep the blade in balance, all cutting edges must be sharpened equally. DO NOT file the tips of the teeth too sharp.

Make sure the width of the 3 sides/4 sides is all the same.

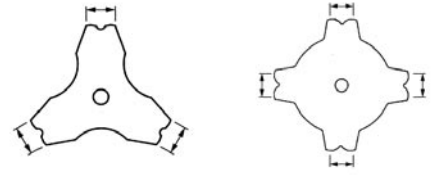

The sharpening angle should be 45° approx. Do not file the tips of the blade too sharp. Leave 0.2~0.5mm unsharpened.

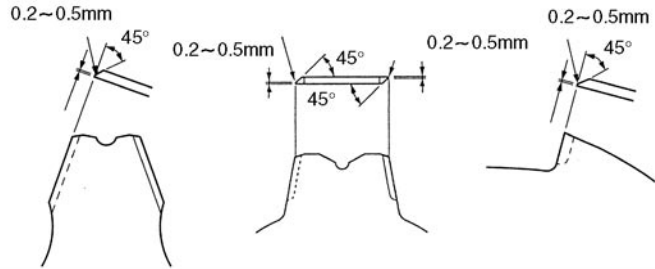

The bottom of each tooth must remain unsharpened. (Blade as viewed from bottom)

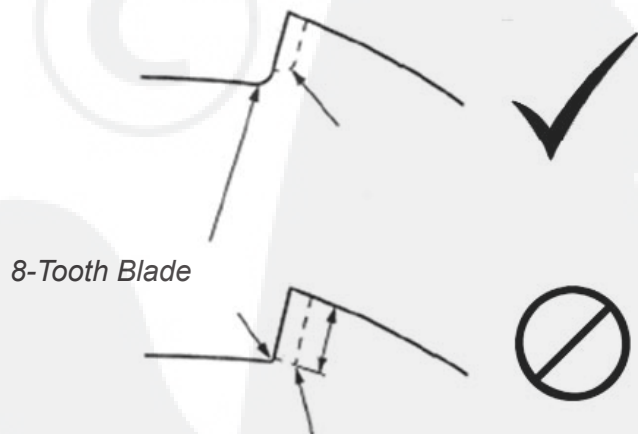
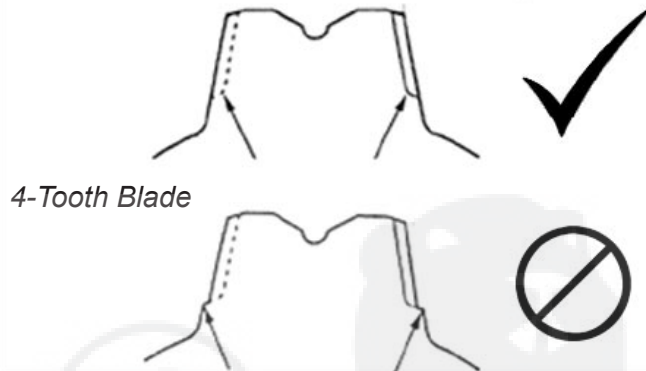

Troubleshooting Guide

Engine Does Not Start

What To Check	Possible Cause	Remedy
Does the engine crank? YES ↓	NO → Faulty recoil starter. Fluid in the crankcase. Internal damage.	Consult with an authorized servicing dealer.
Good compression? YES ↓	NO → Loose spark plug. Excess wear on cylinder, piston, rings.	Tighten and re-test. Consult with an authorized servicing dealer.
Does the tank contain fresh fuel of the proper grade? YES ↓	NO → Fuel incorrect, stale, or contaminated; mixture incorrect.	Refill with clean fresh unleaded gasoline with a pump octane of 87 or higher, mixed with Premium 2-cycle mixing oil at a 50:1 gasoline/oil ratio.
Is fuel visible and moving in the return line when priming? YES ↓	NO → Check for clogged fuel filter and/or vent.	Replace fuel filter or vent as required. Restart.
Is there spark at the spark plug wire terminal? YES ↓	NO → The ignition switch is in "O" (OFF) position. Shorted ignition ground. Faulty ignition unit.	Move switch to "I" (ON) position and re-start. Consult with an authorized servicing dealer.
Check the spark plug.	NO → If the plug is wet, excess fuel may be in the cylinder. The plug is fouled or improperly gapped. The plug is damaged internally or of the wrong size.	Crank the engine with the plug removed, replace the plug, and re-start. Clean and re-gap the plug to 0.6 ~ 0.7 mm. Re-start. Replace the plug with a NGK BMR6A. Re-start.

Troubleshooting Guide (Continued)

Low Power Output

What To Check	Possible Cause	Remedy
Is the engine overheating?	Operator is overworking the unit.	Cut at a slower rate.
	Carburetor mixture is too lean.	Consult with an authorized servicing dealer.
	Improper fuel ratio.	Refill with clean fresh unleaded gasoline with a pump octane of 87 or higher, mixed with Premium 2-cycle mixing oil at a 50:1 gasoline/oil ratio.
	Fan, fan cover, cylinder fins dirty or damaged.	Clean, repair or replace as necessary.
	Carbon deposits on the piston or in the muffler.	Consult with an authorized servicing dealer.
Engine is rough at all speeds. May also have black smoke and/or unburned fuel at the exhaust.	Clogged air cleaner element.	Clean or replace the air filter.
	Loose or damaged spark plug.	Tighten or replace the plug with a NGK BMR6A. Re-start.
	Air leakage or clogged fuel line.	Repair or replace fuel filter and/or fuel line.
	Water in the fuel.	Refill with fresh fuel/oil mixture.
	Piston seizure.	Consult with an authorized servicing dealer.
	Faulty carburetor and/or diaphragm.	Consult with an authorized servicing dealer.
Engine is knocking.	Overheating condition.	See above.
	Improper fuel.	Check fuel octane rating; check for presence of alcohol in the fuel. Refuel as necessary.
	Carbon deposits in the combustion chamber.	Consult with an authorized servicing dealer.

Troubleshooting Guide (Continued)

Additional Problems

Symptom	Possible Cause	Remedy
Poor acceleration.	Clogged air filter.	Clean or replace the air filter.
	Clogged fuel filter.	Replace the fuel filter.
	Lean fuel/air mixture.	Consult with an authorized servicing dealer.
	Idle speed set too low.	Adjust: 2,750 min ⁻¹
Engine stops abruptly.	Switch turned off.	Reset the switch and re-start.
	Fuel tank empty.	Refuel. See page 12.
	Clogged fuel filter.	Replace fuel filter.
	Water in the fuel.	Drain; replace with clean fuel. See page 12.
	Shorted spark plug or loose terminal.	Clean or replace spark plug with a NGK BMR6A. Tighten the terminal.
	Ignition failure.	Replace the ignition unit.
Engine difficult to shut off.	Piston seizure.	Consult with an authorized servicing dealer.
	Ground (stop) wire is disconnected, or switch is defective.	Test and replace as required.
	Overheating due to incorrect spark plug.	Replace spark plug with a NGK BMR6A.
Cutting attachment moves at engine idle.	Overheated engine.	Idle engine until cool.
	Engine idle too high.	Set idle: 2,750 min ⁻¹
	Broken clutch spring or worn clutch spring boss.	Replace spring/shoes as required, check idle speed.
Excessive vibration	Loose attachment holder.	Inspect and re-tighten holders securely.
	Warped or damaged attachment.	Inspect and replace attachment as required.
	Loose gearcase.	Tighten gearcase securely.
Attachment will not rotate	Bent main shaft/worn or damaged bushings.	Inspect and replace as necessary.
	Shaft not installed in powerhead or gearcase.	Inspect and reinstall as required.
	Broken shaft.	Consult with an authorized servicing dealer.
	Damaged gearcase.	Consult with an authorized servicing dealer.

DECLARATION OF CONFORMITY

We hereby declare the Shindaiwa Engine Engine Brushcutter,
Model RM 350 (T350/EC1, C350/EC1).

meets the following respective requirements.

Council Directives:

89/336/EEC as amended

98/37/EC as amended

2000/14/EC as amended

2004/26/EC as amended

Standard taken:

EN 292 parts 1&2

ISO 11806

CISPR 12

Measured sound power level: 113dB(A)

Guaranteed sound power level: T350/EC1:114dB(A), C350/EC1:115dB(A)

Technical documentation is kept by:

K. Maeda DIV. Manager

Engineering Research and Development DIV.

Shindaiwa Kogyo Co., Ltd.

Head office: 6-2-11, Ozuka—Nishi, Asaminami—Ku,
Hiroshima, 731—3167, Japan

TEL: 81-82-849-2003, FAX: 81-82-849-2482

16th February, 2005

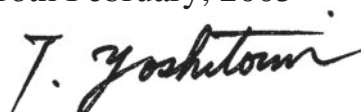

T. Yoshitomi

DIV. Manager

Quality Assurance DIV.

Shindaiwa Kogyo Co., Ltd.

Head office: 6-2-11, Ozuka—Nishi, Asaminami—Ku,
Hiroshima, 731—3167, Japan

TEL: 81-82-849-2206, FAX: 81-82-849-2481

DECLARATION OF CONFORMITY

We hereby declare the Shindaiwa Engine Engine Brushcutter,
Model RM 450 (T450/EC1, B450/EC1).

meets the following respective requirements.

Council Directives:	Standard taken:
89/336/EEC as amended	EN 292 parts 1&2
98/37/EC as amended	ISO 11806
2000/14/EC as amended	CISPR 12
2004/26/EC as amended	

Measured sound power level: 115dB(A)

Guaranteed sound power level: 117dB(A)

Technical documentation is kept by:
K. Maeda DIV. Manager
Engineering Research and Development DIV.

Shindaiwa Kogyo Co., Ltd.

Head office: 6-2-11, Ozuka—Nishi, Asaminami—Ku,
Hiroshima, 731—3167, Japan

TEL: 81-82-849-2003, FAX: 81-82-849-2482

16th February, 2005

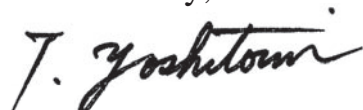

T. Yoshitomi
DIV. Manager
Quality Assurance DIV.

Shindaiwa Kogyo Co., Ltd.

Head office: 6-2-11, Ozuka—Nishi, Asaminami—Ku,
Hiroshima, 731—3167, Japan

TEL: 81-82-849-2206, FAX: 81-82-849-2481

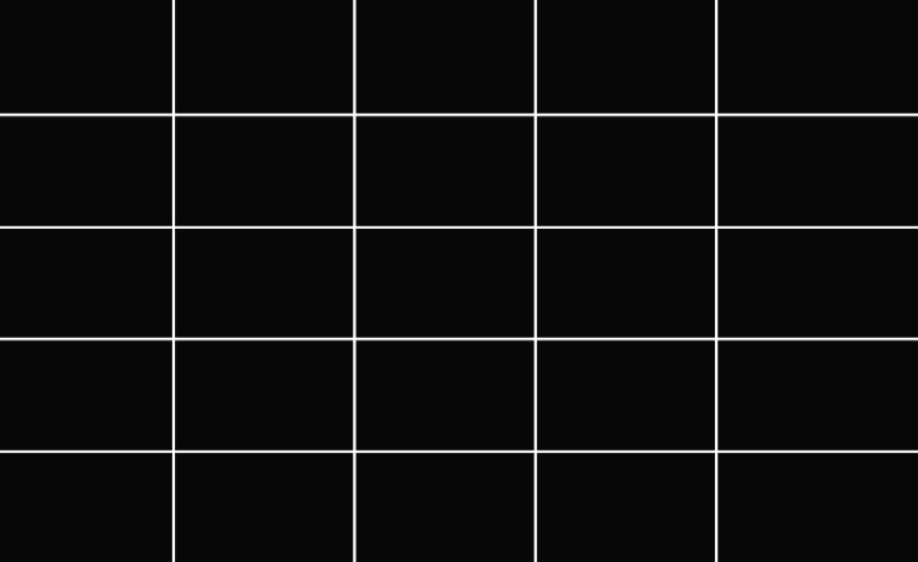

shindaiwa

Shindaiwa Inc.
11975 SW Herman Rd.
Tualatin, Oregon 97062
U.S.A.
Telephone: 503 692-3070
Fax: 503 692-6696
www.shindaiwa.com

Shindaiwa Kogyo Co., Ltd.
6-2-11, Ozuka-Nishi,
Asaminami-Ku, Hiroshima
731-3167, Japan
Telephone: 81-82-849-2220
Fax: 81-82-849-2481

© 2005 Shindaiwa Inc.
Part Number 62102-94310
Revision 02/05
Shindaiwa is a registered trademark of Shindaiwa, Inc.
Specifications subject to change without notice.

