

# **ILLUSTRATED PARTS BREAKDOWN**

**PARTNER**

**12.0 HP, 42" MOWER DECK**

**LAWN TRACTOR**

**MODEL NUMBER 12-107 (P12S105D)**

**PRODUCT NUMBER 954 12 00-30**





# REPAIR PARTS

TRACTOR - - MODEL NUMBER 12-107 (P12S105D), PRODUCT NO. 954 12 00-30  
ELECTRICAL

KEY NO.	PART NO.	DESCRIPTION
1	532 16 34-65	Battery 12 Volt 25 Amp
2	874 76 04-12	Bolt Hex Hd 1/4-20unc X 3/4
8	532 17 66-89	Case Battery Mech Hiinge
16	532 17 61-38	Switch Interlock Push-In
21	532 17 56-88	Harness Asm Light W/4152j
22	532 00 41-52	Bulb Light #1156
24	532 12 47-80	Cable Battery 6 Ga 11"red
25	532 14 61-47	Cable Battery
26	532 17 51-58	Fuse
27	873 51 04-00	Nut Keps Hex 1/4-20 Unc
28	532 12 47-73	Cable Ground 6 Ga 12"black
29	532 12 13-05	Switch Plunger Nc Gray
30	532 17 55-66	Switch Ign
33	532 14 04-01	Key Ign
40	532 17 97-20	Harness Ign
41	871 11 04-08	Bolt Blk Fin Hex 1/4-20
42	532 13 15-63	Cover Terminal Red
43	532 17 88-61	Solenoid
48	532 14 08-44	Adapter Ammeter
52	532 14 19-40	Protection Wire Loop
89	532 18 04-49	Cover Terminal Battery

**NOTE:** All component dimensions given in U. S. inches 1 inch = 25.4 mm.



# REPAIR PARTS

TRACTOR - - MODEL NUMBER 12-107 (P12S105D), PRODUCT NO. 954 12 00-30  
CHASSIS

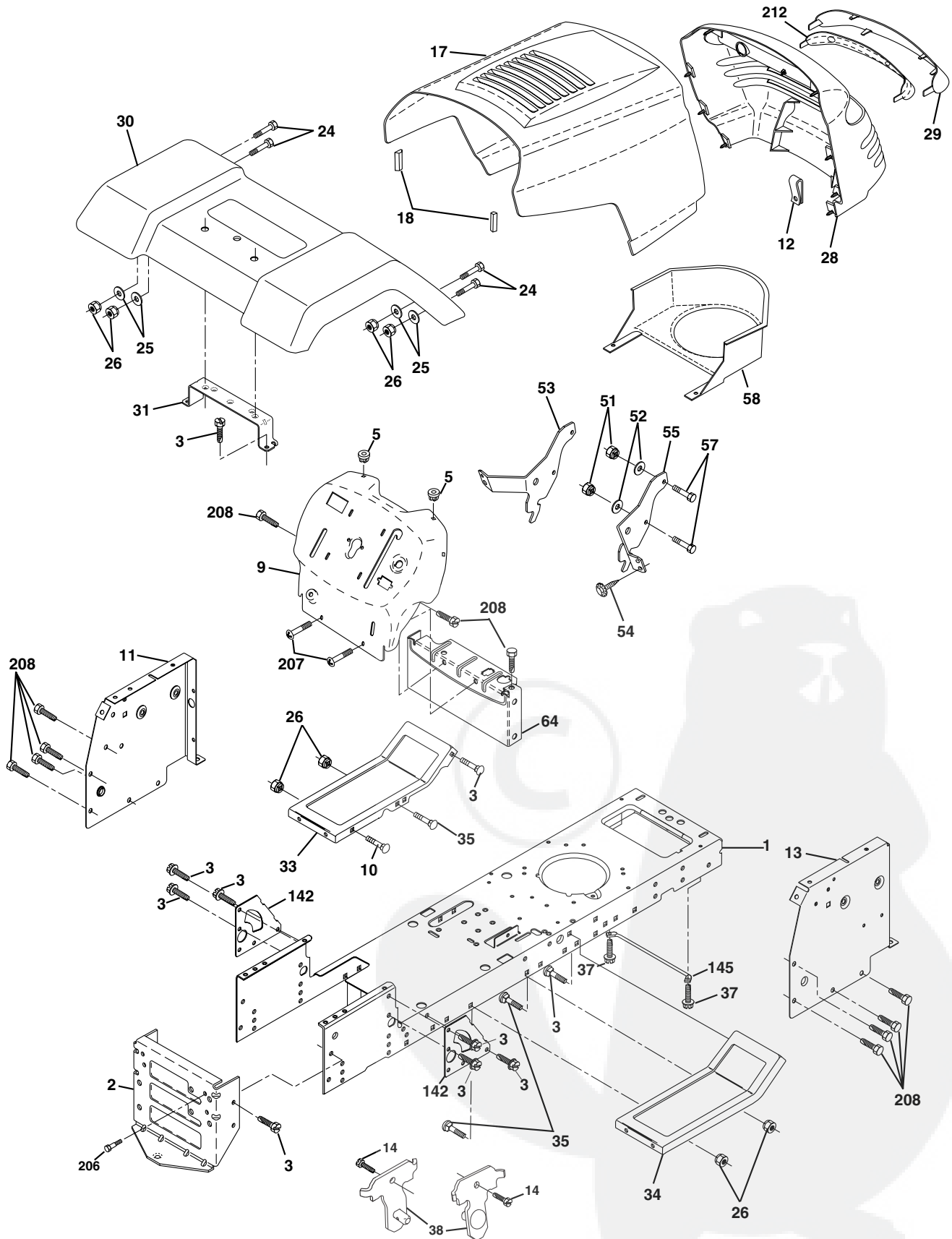

# REPAIR PARTS

TRACTOR - - MODEL NUMBER 12-107 (P12S105D), PRODUCT NO. 954 12 00-30  
CHASSIS

KEY NO.	PART NO.	DESCRIPTION
1	532 17 46-19	Chassis
2	532 17 65-54	Drawbar
3	817 06 06-12	Screw 3/8-16 x .75
5	532 15 52-72	Bumper Hood Dash
9	532 17 21-51	Dash
10	872 14 06-08	Bolt Rdhd Sqnk 3/8-16unc X 1
11	532 15 59-27	Panel Dash LH
12	532 14 56-60	Clip Tinnerman Grille P/L
13	532 17 30-25	Panel Dash RH
14	817 49 06-08	Screw Thdrol 3/8-16 x 1/2
17	532 16 03-82	Hood
18	532 12 69-38	Bumper Hood
24	874 78 06-16	Bolt Fin Hex 3/8-16unc X 1 Gr. 5
25	819 13 13-12	Washer 13/32 X 13/16 X 12 Ga.
26	873 80 06-00	Nut Lock Hex w/Ins 3/8-16 Unc
28	532 17 91-00	Grille/Lens Asm
29	532 16 81-54	Lens Grille
30	532 17 30-26	Fender
31	532 13 66-19	Bracket Fender Repl 109873x
33	532 18 10-57	Footrest Pnt LH
34	532 18 10-58	Footrest Pnt RH
35	872 11 06-06	Bolt Rdhd Sht Sqnk 3/8-16 X3/4
37	817 49 05-08	Screw Thdrol 5/16-18 x 1/2 Tyt
38	532 17 57-10	Bracket Asm Pivot Mower Rear
51	873 80 04-00	Nut Lock w/Insert 1/4-20
52	819 09 14-16	Washer 9/32 x 7/8 x 16 Ga.
53	532 14 46-97	Bracket Grille LH
54	532 16 14-64	Screw Hex Wshd 8-18 x 7/8
55	532 14 46-96	Bracket Grille RH
57	874 78 04-12	Bolt Hex 1/4-20 x 3/4
58	532 15 01-27	Air Duct Private Label
64	532 15 47-98	Dash Lower STLT
142	532 17 57-02	Plate Reinforcement STLT
145	532 15 65-24	Rod Pivot Chassis/Hood
206	532 17 01-65	Bolt Shoulder 5/16-18
207	817 67 05-08	Screw Thdrol 5/16-18 x 1/2
208	817 67 06-08	Screw Thdrol 3/8-16 x 1/2
212	532 15 62-29	Insert Lens Reflective
--	532 00 54-79	Plug Button Blk 359 Dia Choke

**NOTE:** All component dimensions given in U.S. inches  
1 inch = 25.4 mm.

# REPAIR PARTS

TRACTOR - - MODEL NUMBER 12-107 (P12S105D), PRODUCT NO. 954 12 00-30  
DRIVE

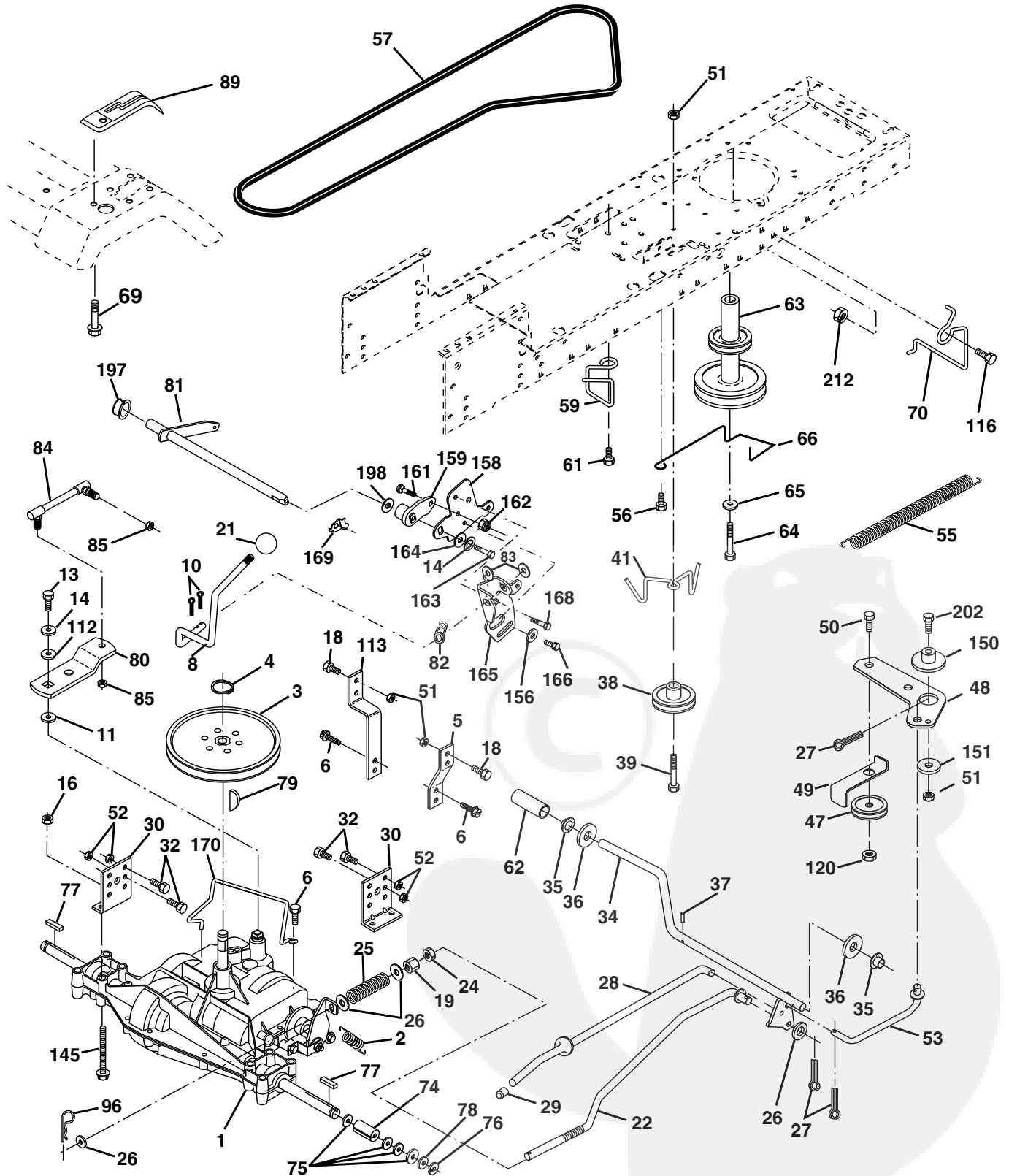

# REPAIR PARTS

**TRACTOR - - MODEL NUMBER 12-107 (P12S105D), PRODUCT NO. 954 12 00-30  
DRIVE**

KEY NO.	PART NO.	DESCRIPTION	KEY NO.	PART NO.	DESCRIPTION
1	-----	Transaxle, Peerless 205-544C (Order parts from transaxle manufacturer)	63	532 17 54-10	Engine Pulley
2	532 14 66-82	Spring Return Brake T/a Zinc	64	871 17 07-64	Bolt Hex
3	532 12 36-66	Pulley Transaxle 18" tires	65	810 04 07-00	Washer Lock Hvy Hlcl Spr 7/16
4	812 00 00-28	Ring Retainer # 5100-62	66	532 15 47-78	Keeper Belt Engine Foolproof
5	532 12 15-20	Strap Torque 30 Degrees	69	532 14 24-32	Screw Hex Wsh Hi-Lo 1/4-1/2 Unc
6	817 06 05-12	Screw 5/16-18 x 3/4	70	532 13 46-83	Guide Belt Mower Drive RH
8	532 16 56-19	Rod Shifter Fender Adj Lt	74	532 13 70-57	Spacer Axle
10	876 02 04-16	Pin Cotter 1/8 x 1 Cad	75	532 12 17-49	Washer 25/32 X 1 1/4 X 16 Ga
11	532 10 57-01	Washer Plate Shf 388 Sq Hole	76	812 00 00-01	E-ring #5133-75
13	874 55 04-12	Bolt 1/4-28 Unf Gr 8 W/Patch	77	532 12 35-83	Key Square 2 0 X 1845/ 1865
14	810 04 04-00	Washer Lock Hvy Helical 1/4	78	532 12 17-48	Washer 25/32 X 1-5/8 X 16 Ga
16	873 80 05-00	Nut Lock	79	532 12 50-96	Key Woodruff
18	874 78 06-16	Bolt, Fin Hex 3/8-16 UNC x 1 Gr. 5	80	532 13 14-86	Arm Shift
19	873 80 06-00	Nut Lock 3/8-16 Unc	81	532 16 55-94	Shaft Asm Cross Tapered 20"t
21	532 10 69-33	Knob	82	532 12 37-82	Spring Torsion T/a
22	532 13 08-04	Rod Brake Blk Zinc 26 840	83	819 17 12-16	Washer 17/32 X 3/4 X 16 Ga
24	873 35 06-00	Nut Hex Jam 3/8-16 Unc	84	532 16 62-28	Link Transaxle
25	532 10 68-88	Spring Rod Brake 2 00 Zinc	85	532 15 03-60	Nut Lock Center 1/4 - 28 FNGTHD
26	819 13 13-16	Washer 13/32 X 13/16 X 16 Ga	89	532 17 37-74	Console Shift STLT
27	876 02 04-12	Pin Cotter 1/8 X 3/4 Cad	96	532 12 47-88	Retainer Spring
28	532 17 57-65	Rod Brake Parking	112	819 09 12-10	Washer 9/32 x 3/4 x 10 Ga.
29	532 07 16-73	Cap Brake Parking	113	532 12 72-85	Strap Torque Lh
30	532 17 49-73	Bracket Mtg Transaxle	116	872 14 06-08	Bolt Rdhd Sq Neck 3/8-16 x 1.00
32	874 76 05-12	Bolt Hex Hd 5/16-18unc X 3/4	120	873 90 06-00	Nut Lock Flg 3/8-16
34	532 17 55-78	Shaft Asm Pedal Foot	145	874 49 05-40	Bolt Hex 5/16-18 Gr. 5
35	532 12 01-83	Bearing Nylon Blk 629 Id	150	532 17 54-56	Spacer Retainer
36	819 21 16-16	Washer 21/32 X 1 X 16 Ga	151	819 13 32-10	Washer 13/32 x 2 x 10
37	532 12 49-63	Pin Roll 3/16 X 1"	156	532 16 60-02	Washer Srrted 5/16 ID x 1.125
38	532 17 91-14	Pulley Idler Composite	158	532 16 55-89	Bracket Shift Mount
39	874 76 06-48	Bolt Fin Hex 3/8-16unc X 3	159	532 16 54-94	Hub Tapered Flange Shift It
41	532 17 55-56	Keeper Belt Retainer Idler	161	872 14 04-06	Bolt Rdhd Sqnk 1/4-20 x 3/4 Gr 5
47	532 12 77-83	Pulley Idler V Groove Plastic	162	873 68 04-00	Nut Crownlock 1/4-20 Unc
48	532 15 44-07	Bellcrank Asm	163	874 78 04-16	Bolt Hex Fin 1/4-20 Unc x 1 Gr 5
49	532 12 32-05	Retainer Belt Style Spring	164	819 09 10-10	Washer 5/8 x .281 x 10 Ga
50	874 76 06-24	Bolt Hex Hd 3/8-16unc X 1-1/2	165	532 16 56-23	Bracket Pivot Lever
51	873 68 06-00	Nut Crownlock 3/8-16 Unc	166	532 16 68-80	Screw 5/16-18 x 5/8
52	873 68 05-00	Nut Crownlock 5/16-18 Unc	168	532 16 54-92	Bolt Shoulder 5/16-18 x .561
53	532 10 57-10	Link Clutch	169	532 16 55-80	Plate Fastening Lt
55	532 10 57-09	Spring Return Clutch 6 75	170	532 17 83-94	Keeper Belt T/A
56	817 06 06-20	Screw 3/8-16 X 1-1/4	197	532 16 96-13	Nyliner, Snap - in
57	532 13 08-01	V-Belt Ground Drive	198	532 16 95-93	Washer, Nyl.
59	532 16 96-91	Keeper Belt Span Ctr	202	872 11 06-14	Bolt, Carriage 3/8 - 16 x 1-3/4
61	817 12 06-14	Screw 3/8-16 x .875	212	532 14 52-12	Nut Flange Hex Lock
62	532 12 48-72	Cover Pedal Blk Round			

**NOTE:** All component dimensions given in U.S. inches  
1 inch = 25.4 mm

# REPAIR PARTS

TRACTOR - - MODEL NUMBER 12-107 (P12S105D), PRODUCT NO. 954 12 00-30  
STEERING

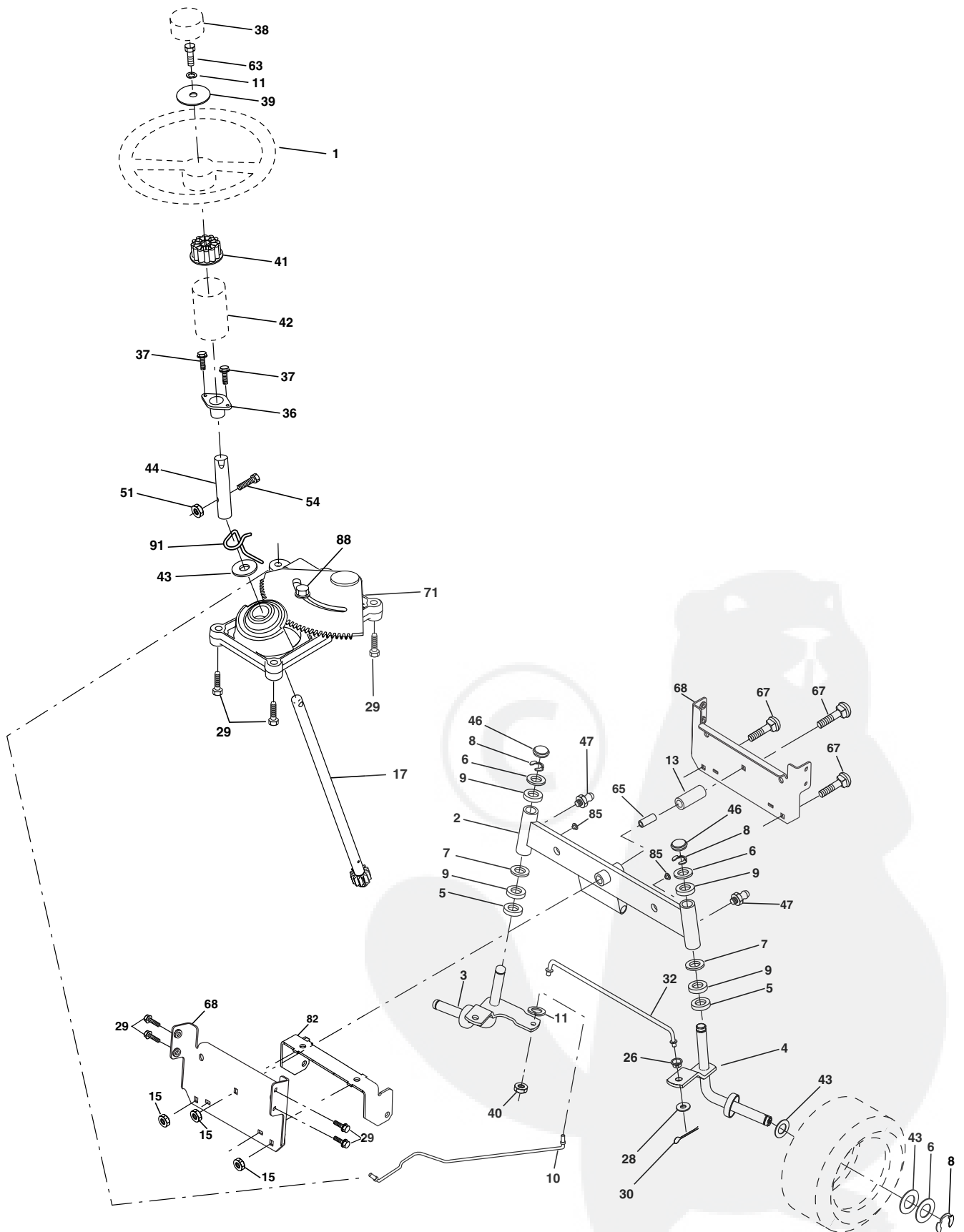



# REPAIR PARTS

TRACTOR - - MODEL NUMBER 12-107 (P12S105D), PRODUCT NO. 954 12 00-30  
STEERING

KEY NO.	PART NO.	DESCRIPTION
1	532 1397-68	Wheel Steering Opp. Sears Blk
2	532 1751-31	Axle Asm Fr
3	532 1698-40	Spindle Asm LH
4	532 1698-39	Spindle Asm RH
5	532 1249-31	Bearing Race Thrust Harden
6	532 1217-48	Washer 25/32 x 1-5/8 x 16 Ga
7	8192720-16	Washer 27/32 x 1-1/4 x 16 Ga
8	8120000-29	Ring Klip #t5304-75
9	532 1249-37	Bearing Col Strg Blk
10	532 1751-21	Link Drag
11	8100406-00	Washer Lock Hvy Hlcl Spr 3/8
13	532 1365-18	Spacer Brace Axle
15	532 1452-12	Nut Hexflange Lock
17	532 1778-76	Shaft Asm Strg
26	532 1268-47	Bushing Link Drag Blk LR
28	8191314-16	Washer 13/32 x 7/8 x 16 Ga
29	8170606-12	Screw 3/8-16 x .75
30	8760204-12	Pin Cotter 1/8 x 3/4 Cad
32	532 1304-65	Rod Tie Wire Form 19 75 Mech
36	532 1550-99	Bushing Strg Nat .623/.618ld
37	532 1529-27	Screw TT #10-32 x 5 x 3/8 Flange
38	532 1401-75	Cap Wheel Steer P/L
39	8191338-12	Washer 13/32 x 2-3/8 x 12 Ga
40	532 1247-01	Nut Lock Center 3/8-24unf
41	532 1007-11	Adaptor Wheel Strg
42	532 1696-33	Boot Shaft Steering
43	532 1217-49	Washer 25/32 X 1 1/4 X 16 Ga
44	532 1537-20	Extension Steering
46	532 1212-32	Cap Spindle Fr Top Blk
47	532 1248-36	Fitting Grease
51	8738005-00	Nut Lock Hx w/Ins 5/16-18 Unc
54	8747805-20	Bolt Fin Hex 5/16-18 Unc x 1-1/4
63	8747806-16	Bolt Fin Hex 3/8-16 UNC Gr. 5
65	532 1603-67	Spacer Brace Axle
67	8721406-18	Bolt RDHD SQ 3/8-16 UNC x 2-1/4
68	532 1698-27	Brace Axle
71	532 1751-46	Steering Asm.
82	532 1698-35	Bracket Susp. Chassis Front
85	532 1338-35	Fastener Christmas Tree
88	532 1751-18	Bolt Shoulder 7/16-20
91	532 1755-53	Clip Steering

**NOTE:** All component dimensions given in U.S. inches  
1 inch = 25.4 mm.

# REPAIR PARTS

TRACTOR - - MODEL NUMBER 12-107 (P12S105D), PRODUCT NO. 954 12 00-30  
ENGINE

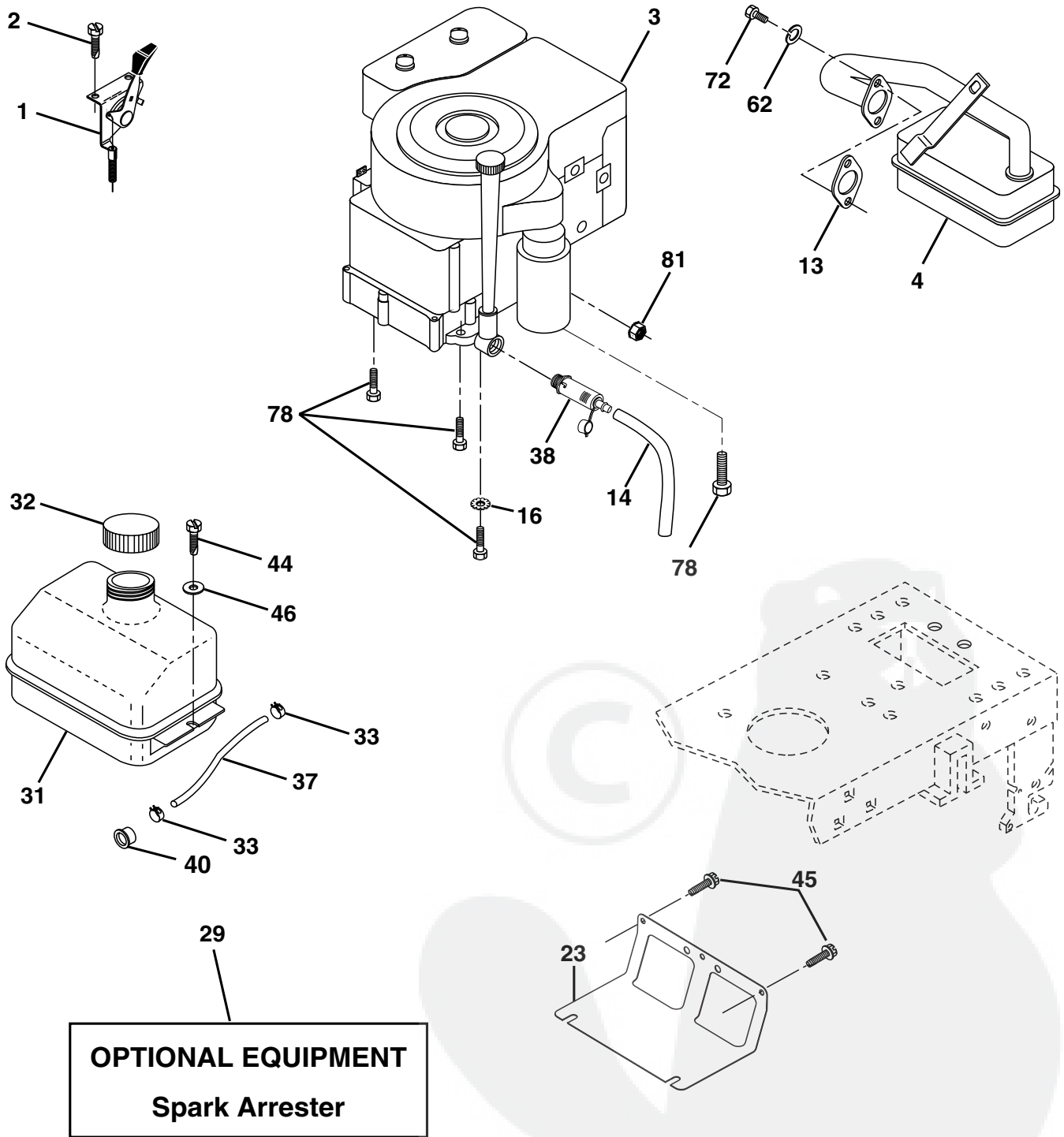

# REPAIR PARTS

TRACTOR - - MODEL NUMBER 12-107 (P12S105D), PRODUCT NO. 954 12 00-30  
ENGINE

KEY NO.	PART NO.	DESCRIPTION
1	532 17 08-65	Control Th/ch Flag Eec
2	817 72 04-08	Screw Hex Thd Cut 1/4-20 x 1/2
3	-----	Engine Briggs & Stratton Model No. 289707 (Order parts from engine manufacturer)
4	532 13 73-48	Muffler LT B&S 12/12 5 HP
13	532 16 52-91	Gasket Eng
14	532 14 84-56	Tube Drain Oil Easy
16	811 05 06-00	Washer Lock Ext Tooth 3/8
23	532 16 98-37	Shield Brn/Dbr Guard
29	532 13 71-80	Kit Spark Arrecter
31	532 10 92-02	Tank Fuel Front 1.25
32	532 14 05-27	Cap Asm Fuel W/sym Vented
33	532 12 34-87	Clamp Hose Blk
37	532 13 70-40	Line Fuel 20"
38	532 14 83-15	Plug Drain Oil Easy
40	532 12 40-28	Bushing Snap Nyl Blk Fuel Line
44	817 67 04-12	Screw Hexwsh Thdrol 1/4-20 x 3/4
45	817 00 06-12	Screw Hexwsh Thdrol 3/8-16 x 3/4
46	819 09 14-16	Washer 9/32 x 7/8 x 16 Ga.
62	810 04 05-00	Washer Lock Hvy Hlcl Spr 5/16
66	532 12 79-51	Stop Throt 3000 Rpm
72	871 07 05-12	Screw Hexhd Cap 5/16-18x3/4
78	817 06 06-20	Screw 3/8-16 x 1-1/4
81	873 51 04-00	Nut Keps Hex 1/4-20 UNC

**NOTE:** All component dimensions given in U.S. inches  
1 inch = 25.4 mm



# REPAIR PARTS

TRACTOR - - MODEL NUMBER 12-107 (P12S105D), PRODUCT NO. 954 12 00-30  
SEAT

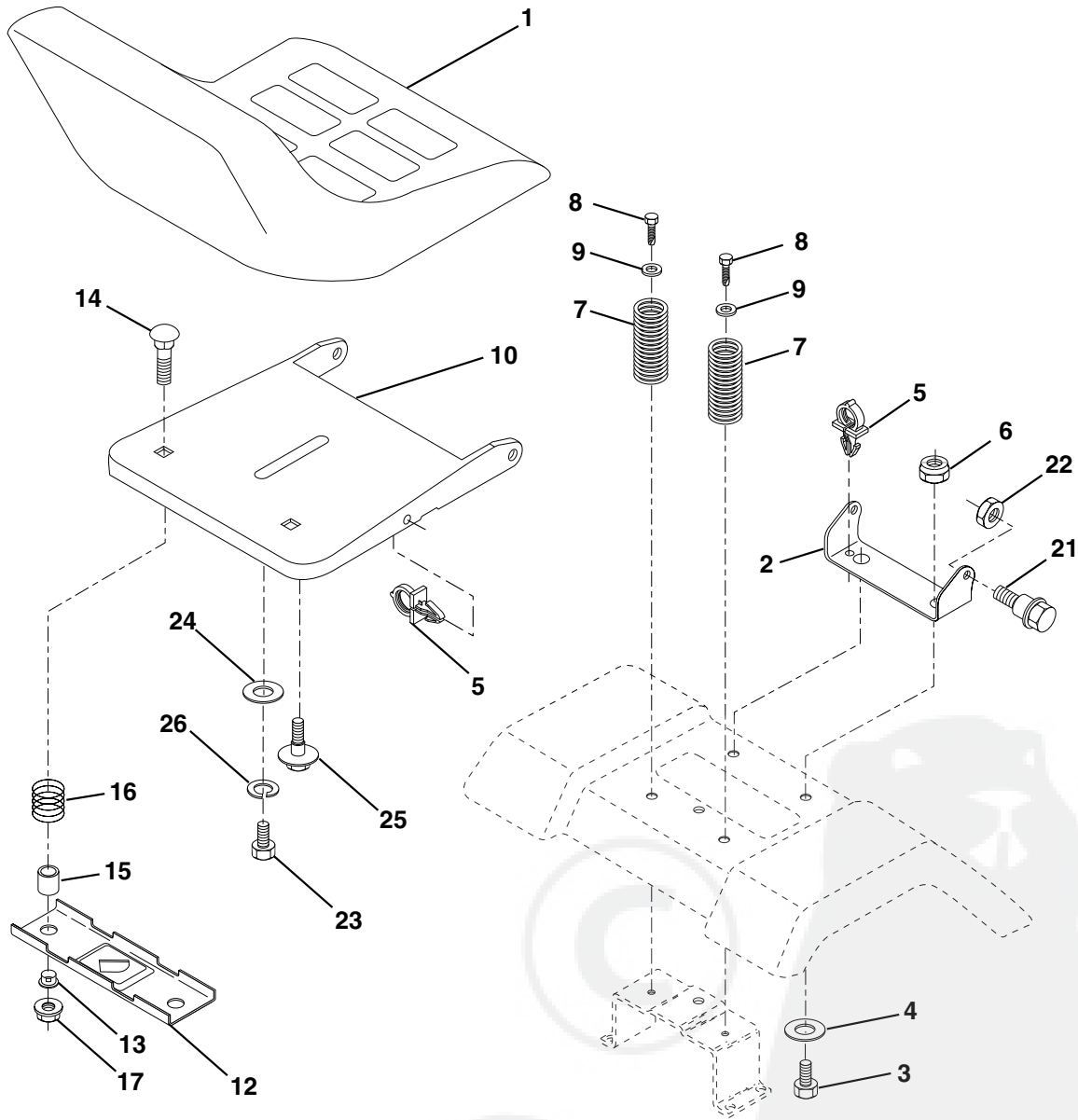

KEY NO.	PART NO.	DESCRIPTION
1	532 14 01-16	Seat
2	532 14 05-51	Bracket Pivot Seat 8 720
3	871 11 06-16	Bolt Fin Hex 3/8-16unc X 1
4	819 13 16-10	Washer 13/32 X 1 X 10 Ga
5	532 14 50-06	Clip Push-In
6	873 80 06-00	Nut Lock Hex w/Wsh 3/8-16 Unc
7	532 12 41-81	Spring Seat Cprsn 2 250 Blk Zi
8	817 00 06-16	Screw 3/8-16 X 1.5
9	819 13 16-14	Washer 13/32 X 1 X 14 Ga.
10	532 17 48-94	Pan Seat
12	532 12 12-46	Bracket Mounting Switch
13	532 12 12-48	Bushing Snap Blk Nyl 50 Id

KEY NO.	PART NO.	DESCRIPTION
14	872 05 04-12	Bolt Rdhd Sht Nk 1/4-20x1-1/2
15	532 13 43-00	Spacer Split 28x 96 Yel Zinc
16	532 12 12-50	Spring Cprsn 1 27 Blk Pnt
17	532 12 39-76	Nut Lock 1/4 Lge Flg Gr 5 Zinc
21	532 17 18-52	Bolt Shoulder 5/16-18 Unc -2A
22	873 80 05-00	Nut Lock Hex W/Insert 5/16-18 UNC
23	871 11 08-14	Bolt Hex Black
24	819 17 19-12	Washer 17/32 X 1-3/16 X 12 Ga.
25	532 12 70-18	Bolt Shoulder 5/16-18 X 62
26	810 04 08-00	Washer Lock Hvy HLCLSPR 1/2

**NOTE:** All component dimensions given in U.S. inches.  
1 inch = 25.4 mm

# REPAIR PARTS

TRACTOR - - MODEL NUMBER 12-107 (P12S105D), PRODUCT NO. 954 12 00-30  
DECALS

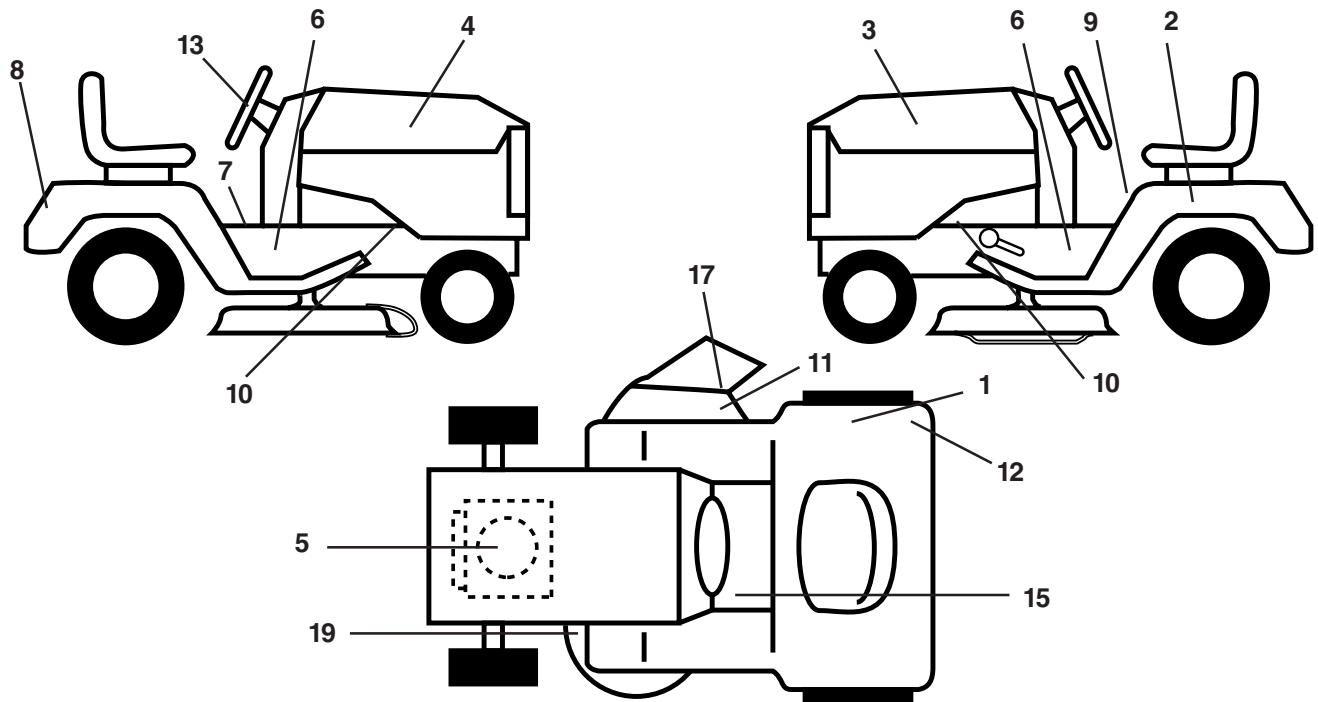

KEY NO.	PART NO.	DESCRIPTION	KEY NO.	PART NO.	DESCRIPTION
1	532 14 54-37	Decal Europe Stand CE	11	532 14 54-94	Decal Mower Cut finger Symbol
2	532 14 50-05	Decal Bat Dan/Poi P/L Symbols	12	532 12 61-87	Decal 100 DbA
3	532 17 59-59	Decal Hood LH	13	532 14 69-98	Decal Strg Wheel Cap
4	532 17 59-58	Decal Hood RH	15	532 15 97-37	Decal Brake/Clutch
5	532 17 08-32	Decal Engine	17	532 17 91-28	Decal Deck "B"
6	532 13 75-88	Decal Chas. Turbo Collection	19	532 16 03-96	Decal V-Belt Sch
7	532 14 08-37	Decal Saddle Brake Parking	--	532 16 25-98	Decal Drawbar Load Limit
8	532 14 09-87	Decal Fender Bernard	--	532 13 83-11	Decal Lift Handle (Lift Handle)
9	532 14 54-98	Decal Read Owners Manual Syms	--	532 18 01-14	Manual Operator's Euro
10	532 15 97-36	Decal Chassis Hot Muffler	--	532 18 01-15	Manual Operator's Scan

## WHEELS & TIRES

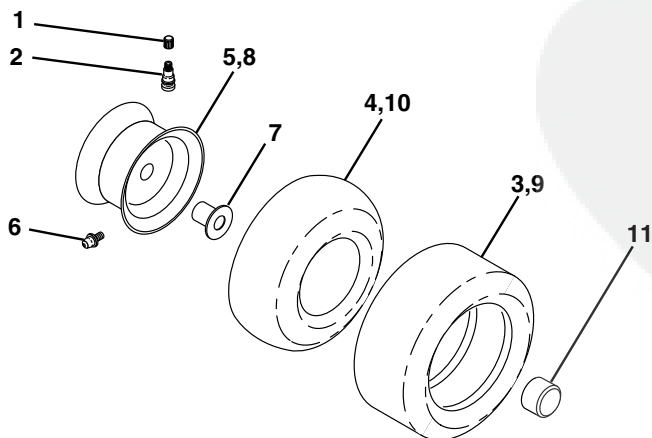

KEY NO.	PART NO.	DESCRIPTION
1	532 05 91-92	Cap Valve Tire
2	532 06 51-39	Stem Valve
3	532 10 62-22	Tire F Ts 15 X 6 0 - 6 Service
4	532 05 99-04	Tube Front (Service Item Only)
5	532 12 51-21	Rim Asm 6" front Yellow Service
6	532 12 49-57	Fitting Grease (Front Wheel Only)
7	532 12 49-59	Bearing Flange (Front Wheel Only)
8	532 12 51-22	Rim Asm 8" rear Yellow Service
9	532 10 62-68	Tire R Ts 18 x 9.5-8 C. Service
10	532 12 49-26	Tube Rear (Service Item Only)
11	532 17 50-39	Cap Axle Blk 1 50 X 1 00

**NOTE:** All component dimensions given in U.S. inches  
1 inch = 25.4 mm

# REPAIR PARTS

TRACTOR - - MODEL NUMBER 12-107 (P12S105D), PRODUCT NO. 954 12 00-30  
MOWER LIFT

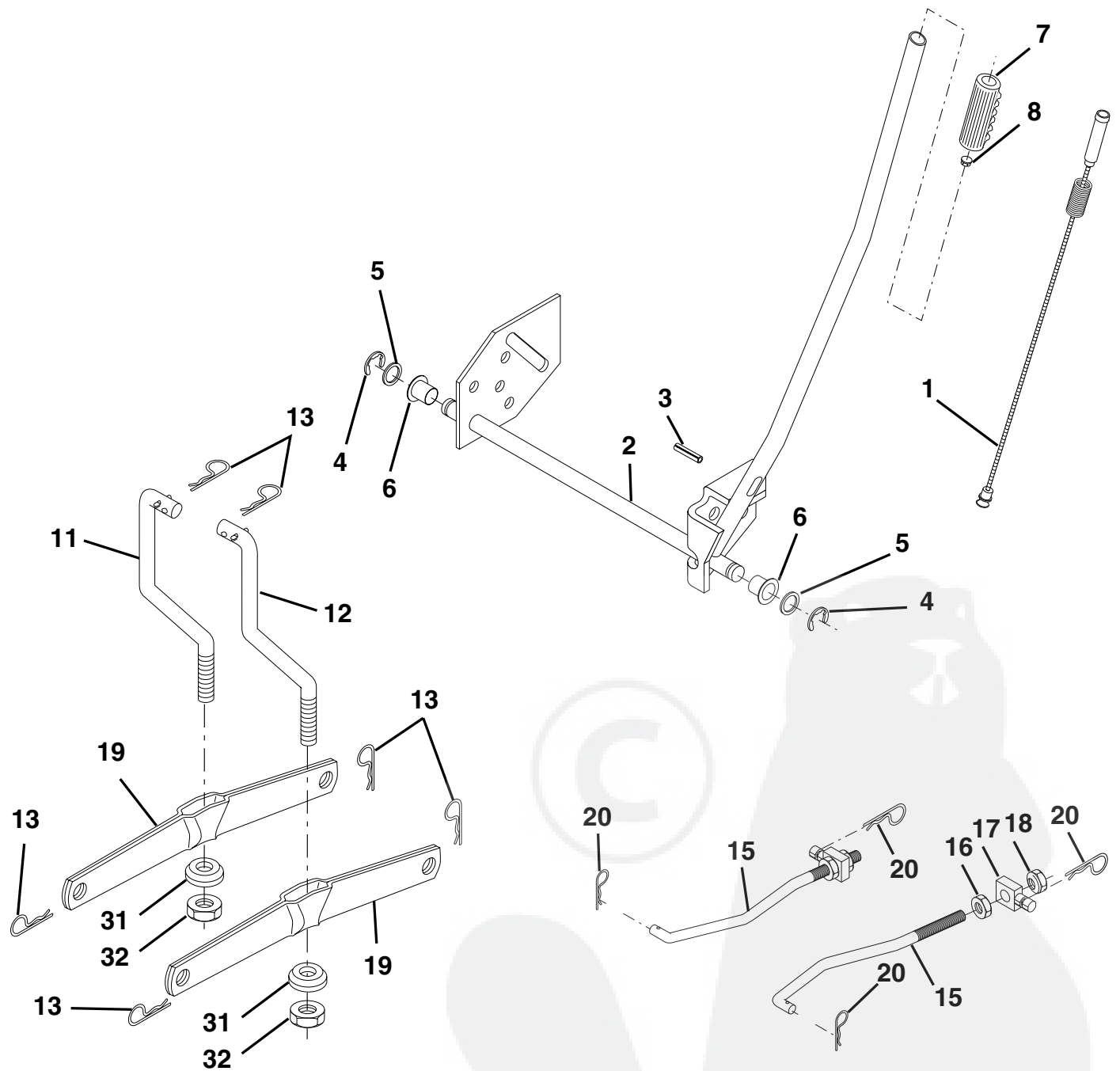

# REPAIR PARTS

TRACTOR - - MODEL NUMBER 12-107 (P12S105D), PRODUCT NO. 954 12 00-30  
MOWER LIFT

KEY NO.	PART NO.	DESCRIPTION
1	532 1594-60	Wire Asm Inner W/Plunger
2	532 1594-71	Shaft Asm Lift
3	532 1057-67	Pin Groove
4	812 0000-02	E Ring #5133-62
5	819 2116-21	Washer PLTD 21/32 X 1 X 21ga
6	532 1201-83	Bearing Nylon Blk 629 Id
7	532 1094-13	Grip Handle Bicycle Matte Blk
8	532 1245-26	Button Plunger Black
11	532 1398-65	Link Lift LH
12	532 1398-66	Link Lift RH
13	532 1246-70	Retainer Spring
15	532 1732-88	Link Front
16	873 3508-00	Nut Jam Hex 1/2-13 Unc
17	532 1756-89	Trunnion
18	873 8008-00	Nut Lock w/wsh 1/2-13 Unc
19	532 1398-68	Arm Suspension Rear
20	532 1635-52	Retainer Spring
31	532 1698-65	Bearing Pvt Lift
32	873 5406-00	Nut Crownlock 3/8-24

**NOTE:** All component dimensions given in U.S. inches  
1 inch = 25.4 mm



# REPAIR PARTS

TRACTOR - - MODEL NUMBER 12-107 (P12S105D), PRODUCT NO. 954 12 00-30  
MOWER DECK

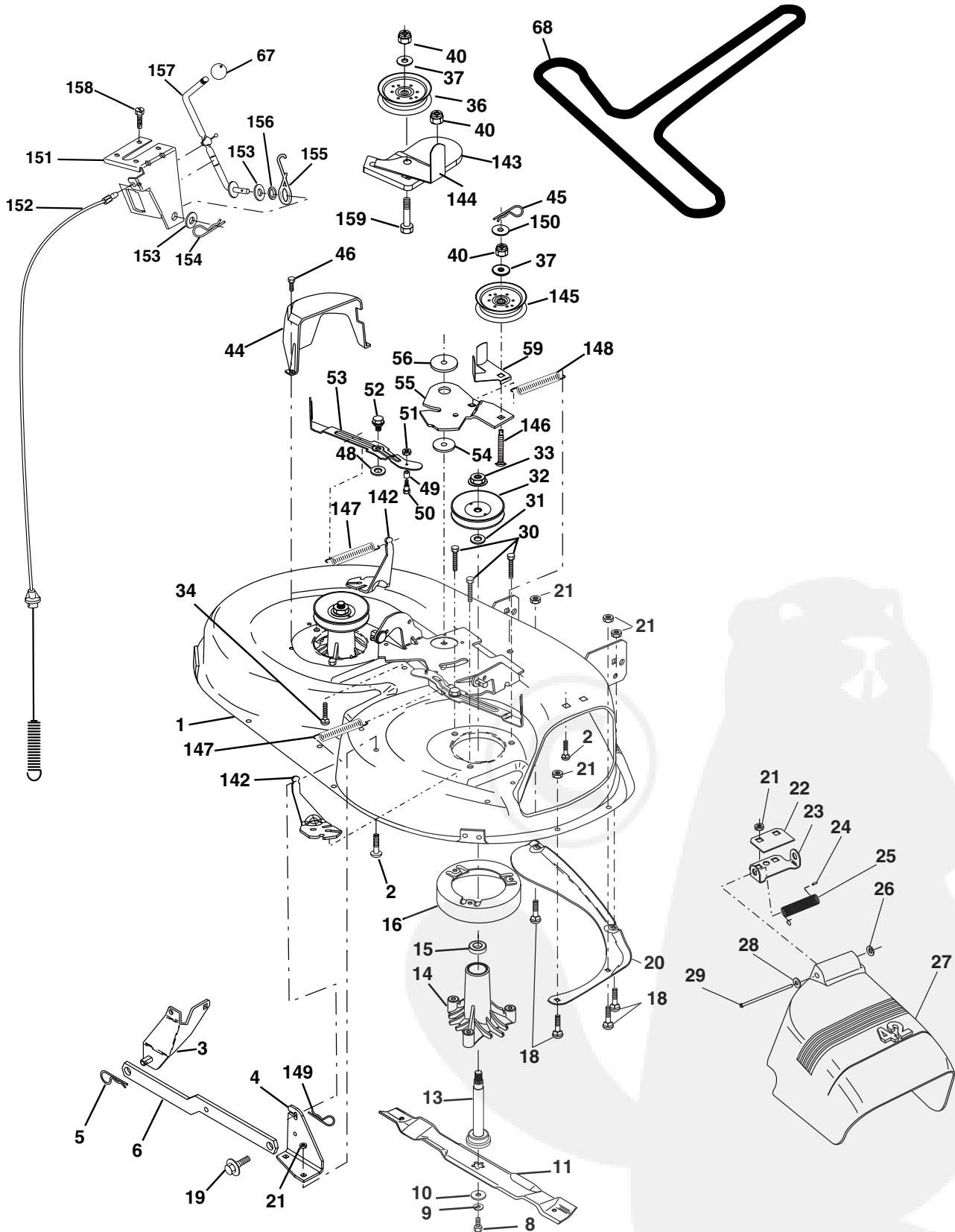



# REPAIR PARTS

TRACTOR - - MODEL NUMBER 12-107 (P12S105D), PRODUCT NO. 954 12 00-30  
MOWER DECK

KEY NO.	PART NO.	DESCRIPTION	KEY NO.	PART NO.	DESCRIPTION
1	532 16 58-92	Housing Asm Mower 42" T-Path	48	532 13 39-44	Washer Hardened Smaller
2	872 14 05-06	Bolt Rdhd Sqnk 5/16-18unc X3/4	49	532 17 42-84	Roller Asm Cam Follower 42" dec
3	532 13 80-17	Bracket Asm Fr Sway Bar 38/42	50	532 13 13-40	Bolt Shldr 10-24 Zinc Gr 5 42"
4	532 16 54-60	Bracket Asm Deck 42" sway Bar	51	532 06 91-80	Nut Lock #10-24 Unc
5	532 12 46-70	Retainer Spring	52	532 13 98-88	Bolt Shoulder 5/16-18 Unc Blkz
6	532 17 80-24	Bar Sway Deck	53	532 13 18-45	Arm Asm Pad Brake
8	532 85 08-57	Bolt 3/8 - 24 X 1.25 Gr 8	54	532 13 39-43	Washer Hardened
9	810 03 06-00	Washer Lock Hvy 3/8 Unplated	55	532 15 50-46	Arm Idler 42" mower LT/YT
10	532 14 02-96	Washer Hard Blade Mower	56	532 16 57-23	Spacer Retainer Pm Mower
11	532 13 84-98	Blade Mower High Lift	59	532 14 10-43	Guard TUV Idler
13	532 13 76-45	Shaft Asm W/Lower Bearing	67	532 10 69-32	Knob Rd 3/8-16 Plstc Thds Blk
14	532 12 87-74	Housing Mandrel Vented (Machd)	68	532 14 49-59	V-Belt Mower
15	532 11 04-85	Bearing Ball Mandrel	142	532 16 58-90	Arm Spring Brake Mower
16	532 17 44-93	Stripper Round Mower	143	532 15 71-09	Bracket Arm Idler 42"
18	872 14 05-05	Bolt Carr 5/16-18 X 5/8	144	532 15 86-34	Keeper Belt 42" Clutch Cable
19	532 13 28-27	Bolt Shoulder	145	532 16 58-88	Pulley Idler Flat
20	532 15 97-70	Baffle Vortex 42"	146	532 17 19-77	Bolt Carriage Idler
21	873 68 05-00	Nut Crown Lock 5/16-18	147	532 13 13-35	Spring Extension
22	532 13 47-53	Stiffener Bracket 42" deck	148	532 16 90-22	Spring Return Idler
23	532 13 12-67	Bracket Deflector Mower 42"	149	532 16 58-98	Retainer Spring Yellow
24	532 10 53-04	Cap Sleeve 80x 112 Blk Mower	150	819 09 12-16	Washer 9/32 x 3/4 x 16 Ga.
25	532 12 37-13	Spring Torsion Deflector 2 52	151	532 16 96-70	Bracket Clutch Cable
26	532 11 04-52	Nut Push Phos & Oil	152	532 16 96-76	Clutch Cable 42"
27	532 17 18-59	Shield Deflector Mower 42"	153	532 16 96-74	Washer Flat 3/8" Type B
28	819 11 10-16	Washer 11/32 X 5/8 X 16 Ga.	154	532 16 96-75	Spring Retainer
29	532 13 14-91	Rod Hinge 42" 6 75 Wlg	155	532 16 96-71	Spring Retention Lvr Cltch Cab
30	532 17 39-84	Screw Thdrol	156	532 16 96-72	Spacer Clutch Cable
31	532 12 99-63	Washer Spacer Mower Vented	157	532 16 96-69	Rod Clutch Cable 3/8"
32	532 15 35-35	Pulley Mandrel 42/44/50	158	817 72 04-08	Screw Hex Thd Cut 1/4-20 x 1/2
33	532 17 83-42	Nut Top Lock Flng	159	872 14 06-14	Bolt Rdhd Sqnk 3/8-16 UNC x 1-3/4
34	872 11 06-14	Bolt Rdhd 3/8-16unc X 1-3/4 Gr5	--	532 18 10-27	Replacement Mower, Complete
36	532 13 14-94	Pulley Idler Flat 3 060	--	532 13 07-94	Mandrel Asm. (Includes Housing, Shaft and Shaft Hardware Only - Pulley Not Included)
37	819 13 13-16	Washer 13/32 X 13/16 X 16			
40	873 68 06-00	Nut, Crownlock 3/8-16 UNC			
44	532 14 00-88	Guard Mandrel LH Black			
45	532 12 47-88	Spring Retainer 1" Zinc/cad			
46	532 13 77-29	Screw Hex Thd Cut 1/4-20x5/8 T			

**NOTE:** All component dimensions given in U.S. inches  
1 inch = 25.4 mm

