

Prod.No: 954 00 13-71
 Engine: B & S 28q777 Type: 0673 Trim: 01
 Transaxle/Hydro: Hydro GEAR 310 - 0650

SPAREPARTS
 107 26 81-61

P

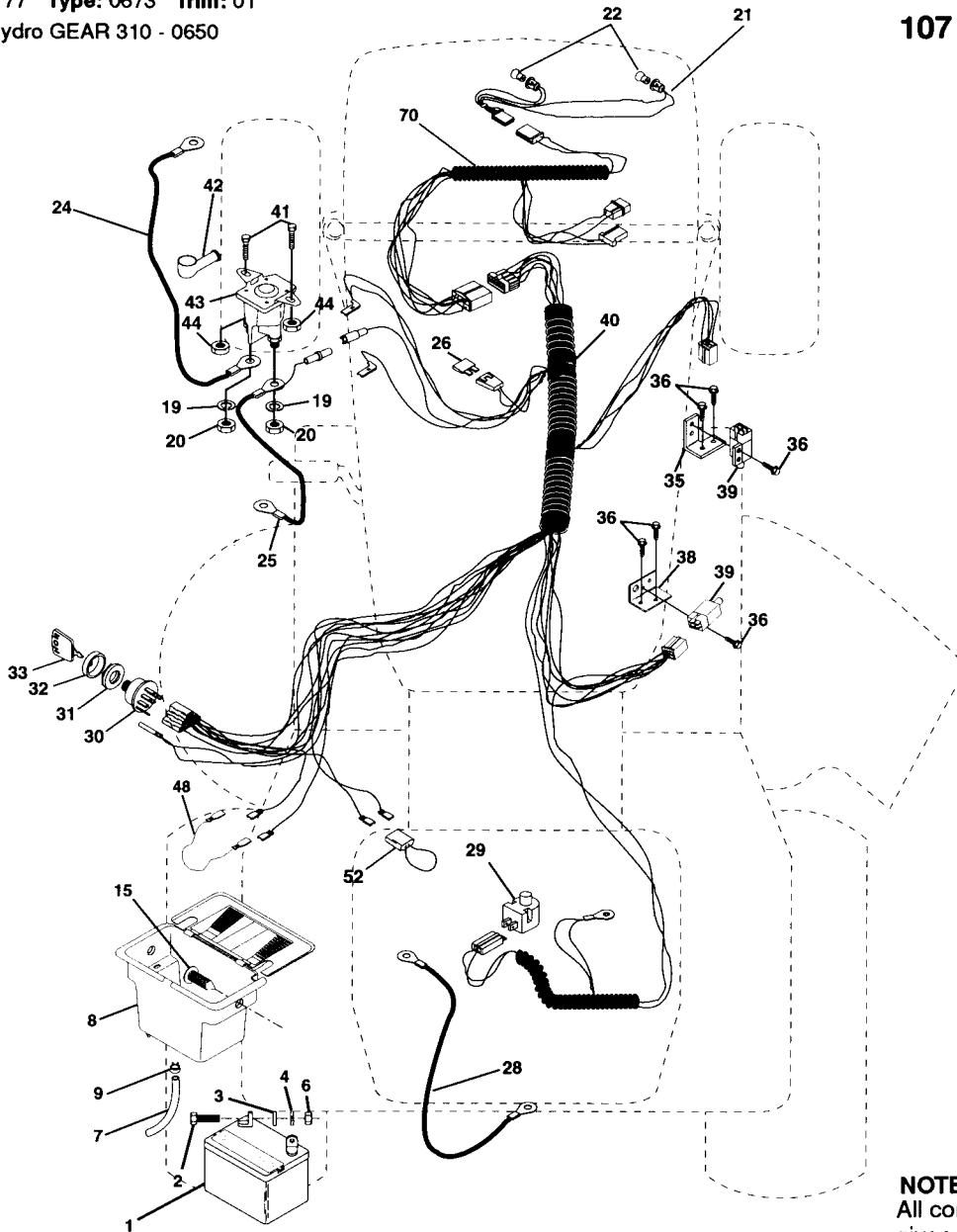

NOTE:
 All component dimensions
 given in U.S. inches
 1 inch = 25.4 mm

Key No.	Part No.	Description	Key No.	Part No.	Description
1	532 14 61-39	Battery 12 Volt 25 Amp Wet ACME	30	532 14 03-01	Switch Ign 4 Pos. w/Lights
2	874 76 04-12	Bolt Hex Hd 1/4-20unc X 3/4	31	532 12 42-11	Nut Ignition
3	734 11 53-01	Washer 9/32 X 5/8 X 16 Ga	32	532 14 12-26	Cover Switch Ignition
4	810 04 04-00	Washer Lock Hvy Helical 1/4	33	532 12 21-47	Key Ign
5	873 22 04-00	Nut Jam Hex 1/4-20 Unc	35	532 10 82-36	Bracket Switch Clutch
6	532 10 92-38	Tube Plastic 20"	36	817 02 10-08	Screw Tap Hex #10-24unc X 1/2
7	532 14 49-40	Battery Case W/2 Holes	38	532 14 03-36	Bracket Switch Interlock
8	532 10 95-96	Clamp Hose Olive	39	532 10 95-53	Switch Intlk Clutch Gry 4 Term
9	532 14 76-88	Fastner Snap-In	40	532 15 12-12	Harness Ign LT P/L Mech HM 95
19	810 04 04-00	Washer Lock 1/4	41	874 78 04-08	Bolt Fin Hex 1/4-20 x 1/2
20	873 22 04-00	Nut Jam Hex 1/4-20 Unc	42	532 13 15-63	Cover Terminal Red
21	532 13 68-50	Harness Asm Light W/4152j	43	532 14 61-54	Solenoid
22	532 00 41-52	Bulb Light #1156	44	873 22 04-00	Nut Keps Hex 1/4-20 Unc
24	532 00 47-99	Cable Battery 6 Ga 11"red	45	532 14 08-44	Adapter Ammeter Rectangular
25	532 14 61-47	Cable Battery 6 Ga 44"red W/16 Wire	46	532 14 19-40	Protection Wire Loop
26	532 10 88-24	Fuse 30 AMP Auto Green	70	532 14 11-64	Harness Eng. B&S
28	532 12 47-73	Cable Ground 6 Ga 12"black			
29	532 12 13-05	Switch Plunger Nc Gray			

A

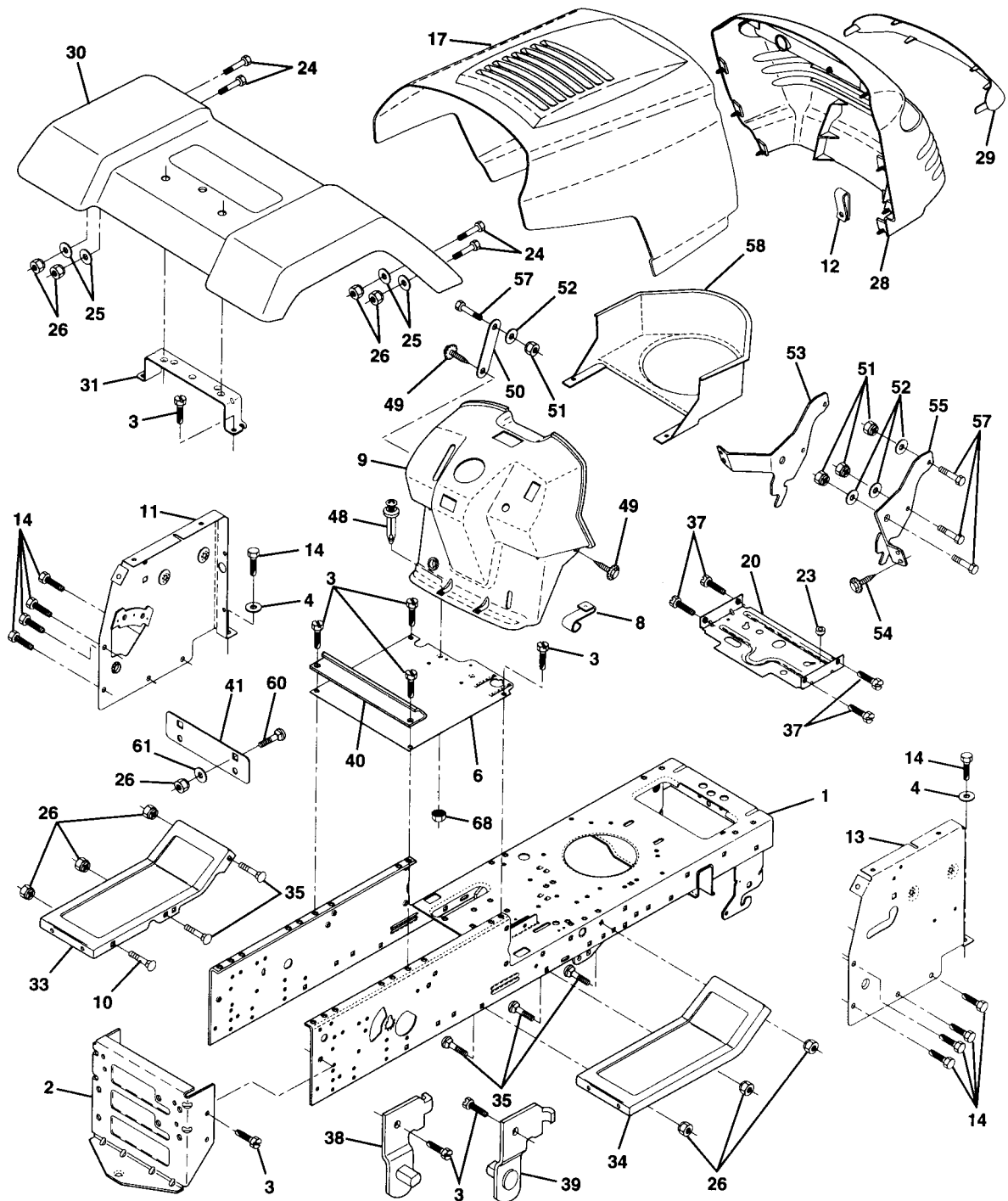

NOTE: All component dimensions given in U.S. inches
1 inch = 25.4 mm

Key No.	Part No.	Description	Key No.	Part No.	Description
1	532 14 55-01	Chassis Widmt. 11Ga.	33	532 14 72-02	Footrest Pnt. Lh Ms-418
2	532 14 03-56	Drawbar Stretch 94	34	532 14 72-03	Footrest Pnt. Rh Ms-418
3	874 49 06-12	Screw Thdrol. 3/8-16 x 3/4 Ty-Tt	35	872 11 06-06	Bolt RdHd Sht. Sqkn. 3/8-16 x 3/4
4	819 13 12-16	Washer 13/32 x 3/4 x 16 Ga.	37	874 49 05-08	Screw Thdrol. 5/16-18 x 1/2 Tyt
6	532 14 52-06	Saddle Lt Fender Shift	38	532 13 98-86	Bracket Asm. Pvt. Lh Mwr. Rear
8	532 12 64-71	Clip Insulator Mtg Hole .406	39	532 13 98-87	Bracket Asm. Pvt. Rh Mwr. Rear
9	532 14 24-65	Dash Private Label Cadm Free	40	532 13 99-77	Spacer Fender Raised LT
10	872 14 06-08	Bolt RdHd Sqkn. 3/8-16 Unc x 1	41	532 13 99-78	Plate Extension Fender LT
11	532 14 69-65	Panel Asm. Dash Lh Private Lable	48	532 13 80-96	Rivet Push Plate D Plastic
12	532 14 56-60	Clip Tinnerman Grille P/L	49	874 76 04-12	Screw Hex Wsh. Thdrol. 1/4-20 x 3/4
13	532 14 69-59	Panel Dash Rh Lt Private Label	50	532 14 27-79	Brace
14	817 49 06-08	Screw Thdrol. 3/8-16 x 1/2 Ty-Tt	51	873 80 04-00	Nut Lock Hex W/Ins. 1/4-20
17	532 14 34-23	Hood Pnt Steel Private Label	52	819 09 14-16	Washer 9/32 x 7/8 x 16 Ga.
20	532 14 52-10	Plate Mtg Battery/Fuel Tank	53	532 14 46-97	Bracket Grille LH
23	532 12 40-28	Bushing Snap Nyl. Blk Fuel Line	54	817 03 08-14	Screw Lock Spider #8 x 7/8
24	874 78 06-16	Bolt Fin Hex 3/8-16 Unc x 1	55	532 14 46-96	Bracket, Grill RH
25	734 11 72-01	Washer 13/32 x 13/16 x 12 Ga.	57	874 78 04-12	Bolt Fin Hex 1/4-20 x 3/4
26	873 68 06-00	Nut Lock Hex w/Ins 3/8-16 Unc	58	532 15 01-27	Air Duct Private Label
28	532 14 34-96	Grill Private Lable Blk	60	872 14 06-06	Bolt Rdhd Sqkn 3/8-16 UNC x 3/4
29	532 14 02-73	Leans Grille Private label	61	819 17 14-16	Washer 17/32 x 7/8 x 16 Ga.
30	532 14 13-24	Fender Pnt Lt Ni Ms-421 94	68	873 68 04-00	Nut Keps Hex 1/4-20 Unc
31	532 13 99-76	Bracket Support Fender	---	532 00 54-79	Plug Button Blk 359 Dia Choke
			---	532 13 40-14	Plug Dome Black

L

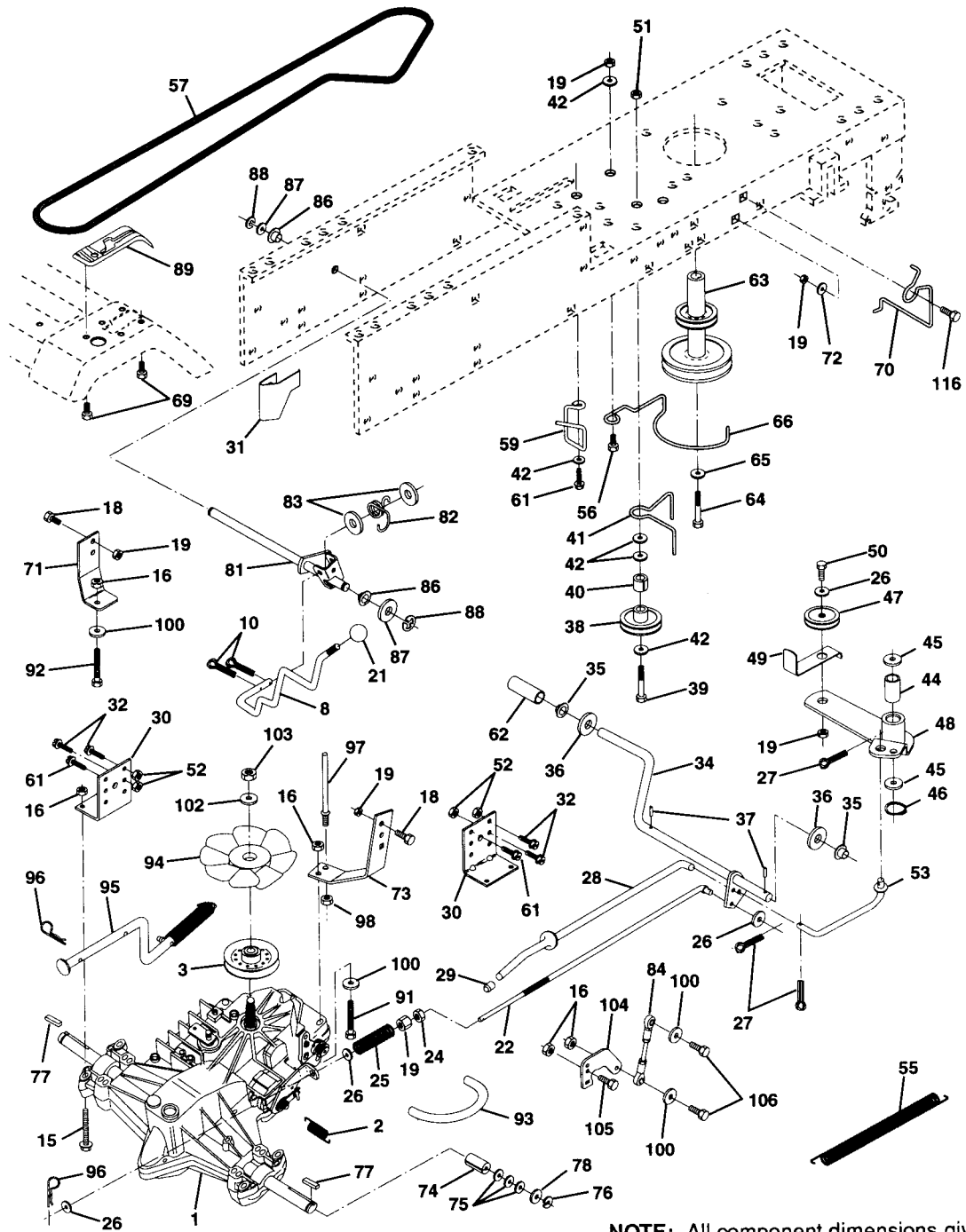

NOTE: All component dimensions given in U.S. inches
1 inch = 25.4 mm

Key No.	Part No.	Description	Key No.	Part No.	Description	Key No.	Part No.	Description
1	532 15 00-71	Transaxle Assembly	46	812 00 00-39	Ring, Klip	82	532 12 37-82	Spring Torsion T/A
2	532 14 24-31	Spring, Return, Brake	47	532 12 77-83	Pulley, Idler, V-Groove	83	734 11 77-71	Washer 17/32 x 3/4 x 16 Ga.
3	532 14 39-95	Pulley, Transaxle	48	532 12 37-89	Bellcrank Assembly	84	532 14 05-48	Rod, Tie Hydro
8	532 14 10-03	Rod Shift Hydro LT	49	532 12 32-05	Retainer, Belt	86	532 07 12-08	Bushing Rod Strig. 629/632 ID
10	876 02 04-16	Pin Cotter 1/8 x 1 CAD	50	874 78 06-24	Bolt	87	734 11 85-71	Washer 21/32 x 1-1/4 x 16 Ga.
15	874 49 05-44	Bolt Fin Hex 5/16-18 Unc	51	873 68 06-00	Nut	88	812 00 00-08	Ring Klip #5304-62
16	873 80 05-00	Nut Lock Hex W/Ins. 5/16-18 Unc P	52	873 68 05-00	Nut Crownlock 5/16-18 UNC	89	532 13 99-88	Console, Shift
18	874 78 06-16	Bolt Fin Hex 3/8-16 Unc x 1 Gr. 5	53	532 10 57-10	Link, Clutch	91	874 78 05-36	Bolt Fin Hex 5/16-18 x 2-1/4
19	873 80 06-00	Nut Lock Hex W/Wsh 3/8-16 Unc	55	532 10 57-09	Spring, Return, Clutch	92	874 78 05-24	Bolt Fin Hex 5/6-18 Unc x 1-1/2
21	532 12 12-74	Knob 1/2-13	56	874 78 06-20	Bolt Fin Hex 3/8-16 x 1-1/4	93	532 14 25-64	Line Fuel Hydro 4"
22	532 14 56-27	Rod, Brake Hydro	57	531 02 06-67	V-Belt, Ground Drive	94	532 14 04-62	Fan, Hydro 7"
24	873 35 06-00	Nut	59	532 14 03-12	Keeper, Center Span	95	532 14 46-43	Control Asm Bypass Hydro
25	532 10 68-88	Spring, Brake Rod	61	874 78 06-12	Screw Thdrol. 3/8-16 x 3/4 Ty. TT	96	532 12 47-88	Retainer Spring 1" Zinc/Cad
26	734 11 72-01	Washer	62	532 12 48-72	Cover, Pedal	97	532 14 04-69	Keeper Bolt Rh Hydro 0750. 18/20"
27	876 02 04-12	Pin Cotter 1/8 x 3/4 CAD.	63	532 14 01-86	Pulley, Engine	98	873 22 06-00	Nut Keps Hex 3/8-16 Unc
28	532 14 52-04	Rod, Parking Brake	64	871 17 07-64	Bolt, Hex	100	734 11 63-01	Washer 11/32 x 3/4 x 16 Ga.
29	532 07 16-73	Cap, Parking Brake	65	810 04 07-00	Washer	102	532 14 13-22	Washer Belleville .501D x 1.50D
30	532 13 08-07	Bracket, Transaxle	66	532 12 99-21	Keeper Belt Engine	103	532 61 08-00	Nut Hex Jam Toplock 1/2-20 Unf
31	532 12 72-75	Keeper Belt Lh	69	532 14 24-32	Screw	104	532 14 01-56	Arm, Control Hydro
32	874 78 05-12	Bolt Hex Hd 5/16-18 Unc x 3/4	70	532 13 46-83	Keeper Belt Engine	105	871 07 05-16	Screw Cap Hex 5/16 x 18 x 1
34	532 14 90-01	Shaft, Foot Pedal	71	532 14 01-58	Strap Torque Lh Hydro 18/20" T	106	874 78 05-20	Bolt Fin Hex 5/16-18 Unc x 1-1/4
35	532 12 01-83	Bearing, Nylon	72	734 11 74-41	Washer 13/32 x 1-1/4 x 12 Gauge			
36	734 11 85-71	Washer	73	532 14 01-57	Strap Torque Rh Hydro 18/20" T			
37	532 12 49-63	Pin, Roll	74	532 12 11-99	Spacer, Split			
38	532 12 36-74	Pulley, Idler, Flat	75	532 12 17-49	Washer 25/32 x 1-1/4 x 16 Gauge			
39	874 76 06-44	Bolt	76	812 00 00-01	E-Ring			
40	533 00 44-70	Spacer, Split	77	532 12 35-83	Key, Square			
41	532 10 90-70	Keeper, Belt Retainer	78	532 12 17-48	Washer 25/32 x 1-5/8 x 16 Gauge			
42	734 11 72-01	Washer 13/32 x 13/16 x 12 Gauge	81	532 14 01-54	Shaft Asm. Cross Hydro 20" Tires			
44	532 10 57-06	Bearing, Nylon						
45	532 11 08-12	Washer, Hardened						

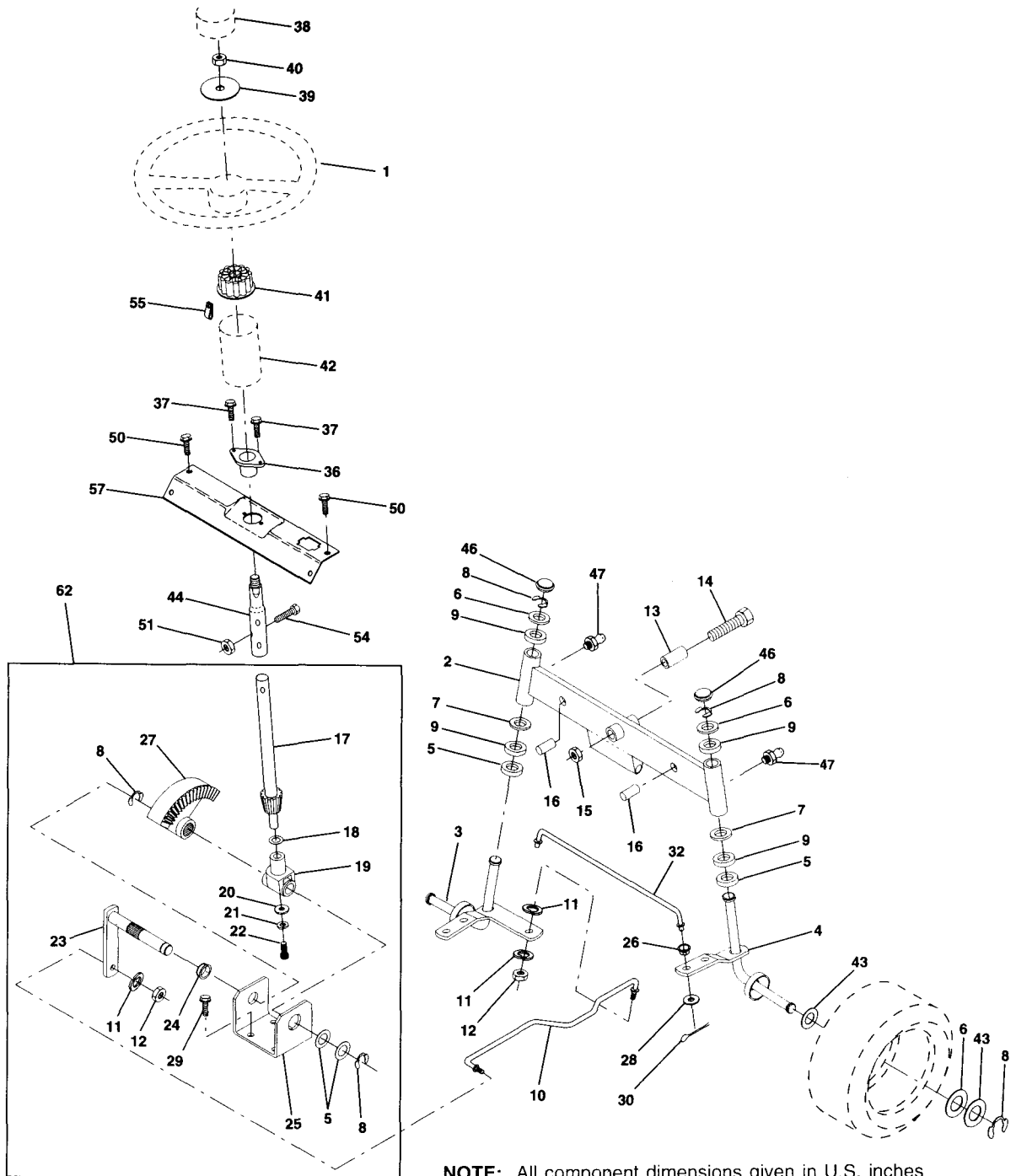

NOTE: All component dimensions given in U.S. inches
1 inch = 25.4 mm

Key No.	Part No.	Description	Key No.	Part No.	Description
1	532 13 97-68	Wheel Steering Opp Sears Blk	25	532 12 40-36	Bracket Steering
2	532 14 20-33	Axle Asm Fr LT W/gzks 38/42	26	532 12 68-47	Bushing Link Drag Blk LR
3	532 13 52-27	Spindle Asm LH	27	532 13 68-74	Gear Sector 22 Teeth
4	532 13 52-28	Spindle Asm RH	28	734 11 72-01	Washer 13/32 X 7/8 X 16 Ga
5	532 00 62-66	Bearing Race Thrust Harden	29	874 78 06-12	Screw Thdrol 3/8-16x3/4 Ty-tt
6	532 12 17-48	Washer 25/32 X 1-5/8 X 16 Ga	30	876 02 04-12	Pin Cotter 1/8 X 3/4 Cad
7	819 27 20-16	Washer 27/32 X 1-1/4 X 16 Ga	32	532 13 04-65	Rod Tie Wire Form 19 75 Mech
8	812 00 00-29	Ring Klip #t5304-75	36	532 10 28-03	Bushing Steering
9	532 00 33-66	Bearing Col Strg Blk	37	817 43 10-08	Screw Slftp #10-16 X 1/2 Ty-b
10	532 13 04-68	Link Drag Sol Ball Jt 20 064	38	532 14 01-75	Cap Wheel Steer P/L
11	810 04 06-00	Washer Lock Hvy Hlcl Spr 3/8	39	819 13 38-08	Washer 13/32 x 2-3/8 x 8 Ga
12	873 61 06-00	Nut Fin Hex 3/8-24 Unf	40	873 61 06-00	Nut Lock Center 3/8-24 Unf
13	532 11 04-38	Spacer Bearing Axle Front	41	532 10 48-20	Adapter Wheel Strg .640/.635
14	874 01 10-56	Bolt Hex 5/8-11 Unc X 3-1/2	42	532 14 02-16	Boot Shaft Steering
15	873 68 10-00	Nut Lock Flange 5/8-11 Unc	43	532 12 17-49	Washer 25/32 X 1 1/4 X 16 Ga
16	532 13 26-24	Pin Axle 5/8 X 1 55/1 54 Lg	44	532 14 66-90	Shaft Extension Steering
17	532 14 01-76	Shaft Asm Strg	46	532 12 12-32	Cap Spindle Fr Top Blk
18	532 05 70-79	Washer Thrust 515x 750x 033	47	532 12 48-36	Fitting Grease
19	532 12 40-35	Support Shaft	50	874 76 04-12	Screw Hex Wsh Thdrol 1/4-20 x 3/4
20	532 12 66-84	Washer Shim 1/4 X 5/8 X 062	51	873 80 05-00	Nut Lock Hex W/Ins. 5/16-18 Unc P
21	810 04 04-00	Washer Lock Hvy Helical 1/4	54	874 78 05-20	Bolt Fin Hex 5/16-18 Unc P
22	871 07 04-10	Screw Hex Socket 1/4-20 X 5/8	55	532 14 02-85	Clip Timmerman
23	532 12 75-01	Shaft Asm Pittman	57	532 14 01-72	Support Shaft Steering
24	532 10 98-16	Nyliner Snap In	62	532 14 96-86	Kit Steering Asm Service

F

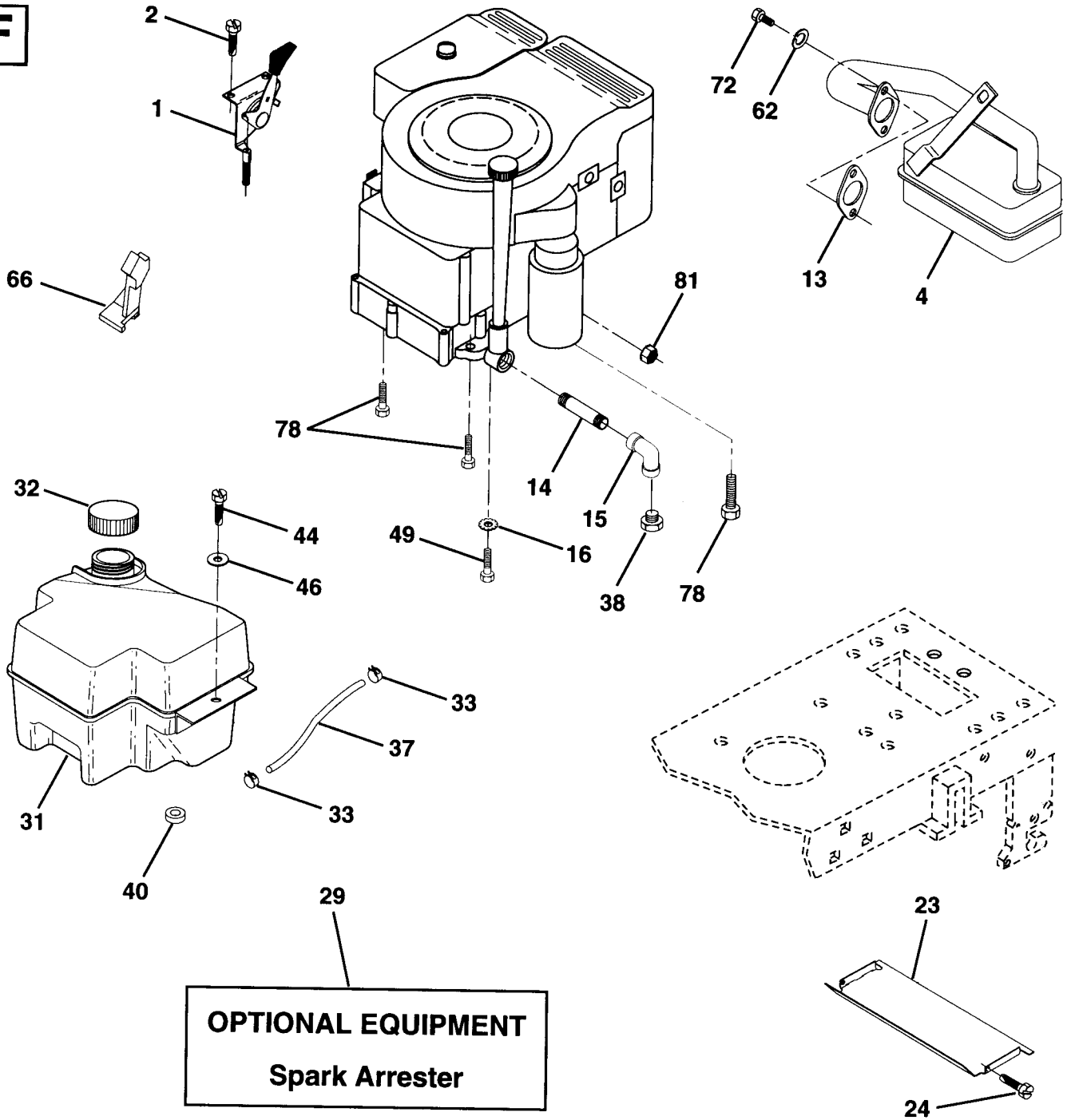

OPTIONAL EQUIPMENT
Spark Arrester

NOTE: All component dimensions given in U.S. inches
1 inch = 25.4 mm

Key No.	Part No.	Description	Key No.	Part No.	Description
1	532 14 13-59	Control Th/ch LH Blk Flag Eec	33	532 12 34-87	CLAMP Hose Blk
2	874 78 04-10	Screw Hex Thd Cut 1/4-20x5/8 T	37	532 13 70-40	Line Fuel 9 20"
4	532 13 73-52	Muffler LT B&S 14 HP	38	-----	Plug Oil Drain (Order From Engine Manufacturer)
13	532 27 22-93	Gasket Eng 1 313 Id Tin Plated	40	532 12 40-28	Bushing Snap Nyl Blk Fuel Line
14	813 28 03-24	Nipple Pipe 3/8 Npt X 3"	44	874 76 02-12	Screw Hexwsh Thdrol 1/4-20x3/4
15	813 20 03-00	Elbow Std 90 Degree 3/8-18 Npt	46	819 09 14-16	Washer 9/32 X 7/8 X 16ga
16	810 04 06-00	Washer Lock Ext Tooth 3/8	49	874 78 06-16	Screw Thdrol 3/8-16 x 1 Ty-tt
23	532 12 89-53	Shield Heat Browning LT/YT	66	532 12 79-51	Stop Throttle 3000
24	817 02 10-08	Screw Tap Hex #10-24unc X 1/2	62	810 04 05-00	Washer Lock Hvy Hlcl Spr 5/16
29	532 13 71-80	Kit Spark Arrestor 1 25	72	871 07 05-12	Screw Hexhd Cap 5/16-18x3/4
31	532 14 02-80	Tank Fuel Front 2 00	78	874 78 06-20	Screw Thdrol 3/8-16x1-1/4 TYTT
32	532 14 05-27	Cap Asm Fuel W/sym Vented	81	873 68 04-00	Nut Flange 1/4-20 Starter Nut

C

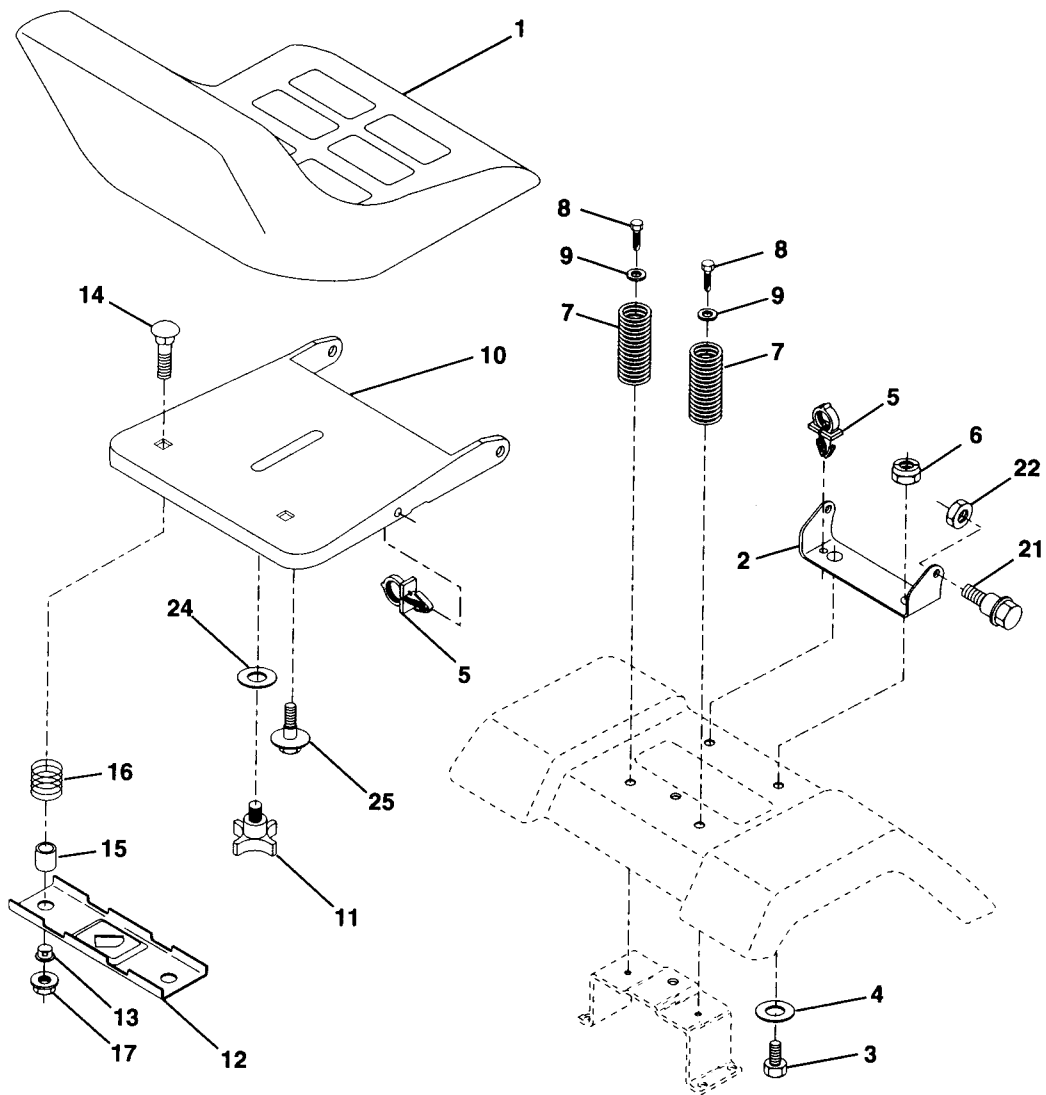

NOTE: All component dimensions given in U.S. inches
1 inch = 25.4 mm

Key No.	Part No.	Description	Key No.	Part No.	Description
1	532 14 01-17	Seat 2400/1416 Blk/blk Std	13	532 12 12-48	Bushing Snap Blk Nyl 50 Id
2	532 14 05-51	Bracket Pivot Seat	14	872 05 04-11	Bolt Rdhd Sht Nk 1/4-20x1-3/8
3	874 78 06-16	Bolt Fin Hex 3/8-16unc X 1	15	532 13 43-00	Spacer Split 28x 96 Yel Zinc
4	819 13 16-10	Washer 13/32 X 3/4 X 10 Ga	16	532 12 12-50	Spring Cprsn 1 27 Blk Pnt
5	532 14 50-06	Nut Lock Hex w/Ins 3/8-16 Unc	17	873 68 04-00	Nut Lock 1/4 Lge Flg Gr 5 Zinc
6	873 68 06-00	Nut Lock Hex w/Ins 3/8-16 Unc	21	532 13 98-88	BOLT Shoulder 5/16-18 Type T.T.T.R.
7	532 12 41-81	Spring Seat Cprsn 2 250 Blk Zi	22	873 80 05-00	Nut Lock Hex w/Ins 5/16-18
8	874 78 06-16	Screw Thdrol 3/8-16 X 1 Ty-tt	24	819 17 19-12	Washer 17/32 X 1-3/16 X 12 Ga
9	819 13 16-14	Washer 13/32 X 1 X 14 Ga	25	532 12 70-18	Bolt Shoulder 5/16-18 X 62
10	532 14 05-52	Pan Seat			
11	532 12 00-68	Knob Seat 1/2-13unc Blk			
12	532 12 12-46	Bracket Mounting Switch			

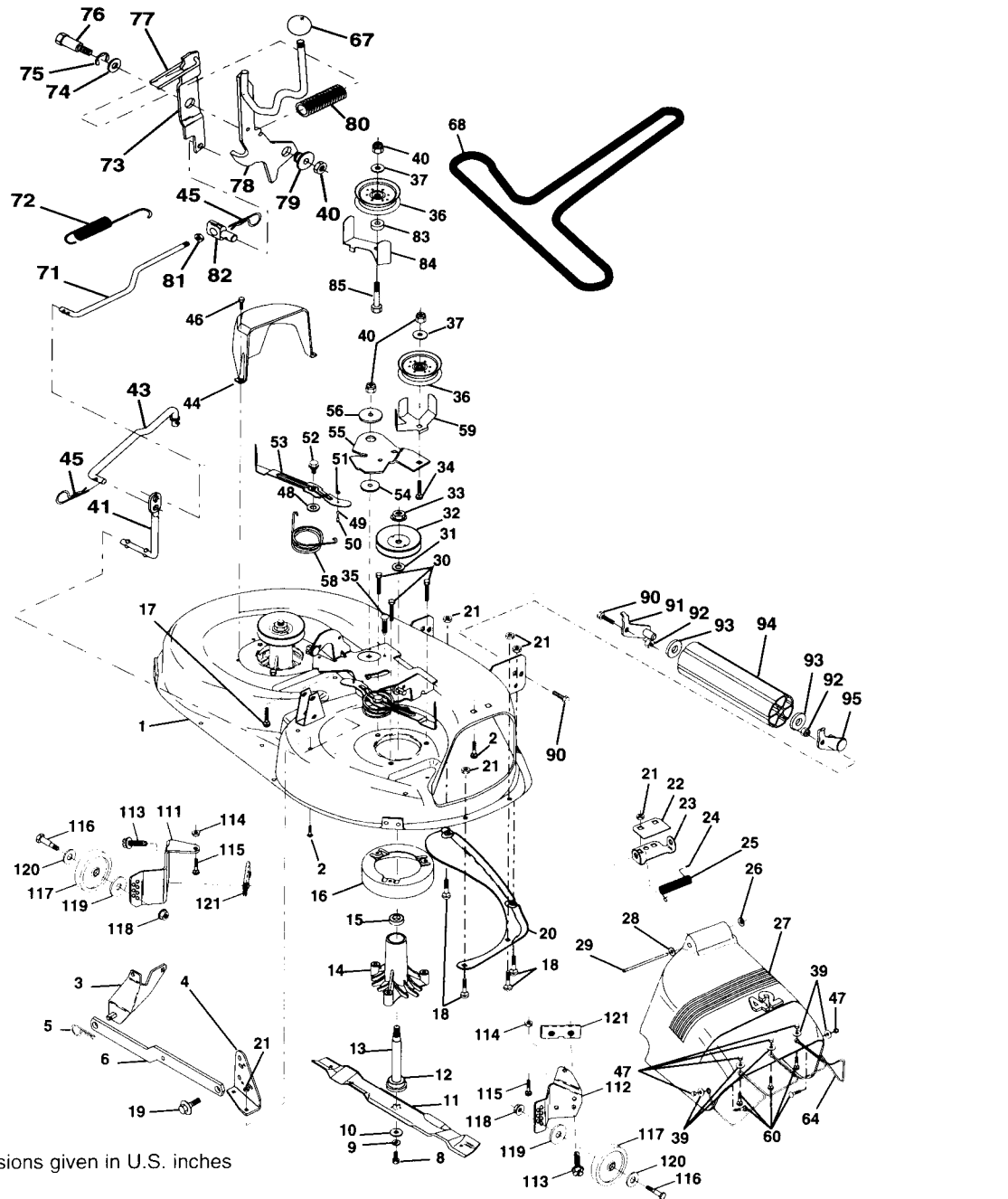

NOTE: All component dimensions given in U.S. inches
1 inch = 25.4 mm.

Key No.	Part No.	Description	Key No.	Part No.	Description	Key No.	Part No.	Description
1	532 14 43-93	Asm., Mower Deck 42"	39	532 14 65-70	Washer 7/32 X 7/16 X 18 Ga.	84	532 14 43-94	Keeper Belt Idler Fixed
2	872 14 05-06	Bolt	40	873 68 06-00	Nut, Carriage 3/8-16	85	872 14 06-18	Bolt Rdhd Sqnk 3/8-16 x 2-1/4
3	532 13 80-17	Asm., Bar, Anti-Sway	41	532 13 35-51	Rod Pivot w/nibs	90	874 78 06-16	Bolt Hex 3/8-16 x 1
4	532 13 84-40	Asm., Bracket, Anti-Sway Bar	43	532 14 00-83	Rod Clutch Secondary w/nibs	91	532 13 22-74	Asm., Bracket, Nose Roller Lh
5	532 08 59-02	Spring, Retainer	44	532 14 00-88	Cover, Mandrel, Lh	92	873 68 06-00	Nut
6	532 13 08-32	Arm, Suspension, Rear	45	532 12 47-88	Spring Retainer 1"	93	819 17 14-16	Washer 17/32 x 7/8 x 16 Ga.
8	532 85 08-57	Bolt 3/8-24 x 1,25 Gr. 8	46	532 13 77-29	Screw, Thdrol 1/4-20 x 5/8	94	532 13 22-64	Nose Roller
9	810 04 06-00	Washer, Lock	47	532 14 59-90	Nut Acorn M5 x 0.8	95	532 13 22-73	Asm., Bracket, Nose Roller Rh
10	532 14 02-96	Washer, Hardened	48	532 13 39-44	Washer Hardened Smaller	111	532 14 03-53	Support, Bracket, Gauge Wheel Lh
11	531 02 06-63	Blade, Mower, High Lift	49	532 13 39-40	Roller Asm Cam Folr Mech Decks	112	532 13 22-62	Support, Bracket, Gauge Wheel Rh
12	532 12 98-95	Bearing, Ball	50	532 13 13-40	Bolt Shoulder 10-24	113	874 78 05-12	Screw Thdrol 5/16-18 x 3/4 Tyt
13	532 13 76-45	Asm., Shaft, Mandrel, Vented (includes key no. 12)	51	532 06 91-80	Nut Lock #10-24	114	873 68 05-00	Nut, Keps 5/16-18
14	532 12 87-74	Housing, Mandrel, Vented	52	532 13 98-88	Bolt Shoulder 5/16-18	115	872 11 05-04	Bolt Carriage 5/16-18 x 1/2
15	532 11 04-85	Bearing, Ball, Mandrel	53	532 13 18-45	Arm Asm Brake Pad	116	532 00 48-98	Bolt, Shoulder
16	532 14 03-29	Stripper Round Mower	54	532 13 39-43	Washer, Hardened	117	532 10 54-55	Wheel, Gauge
17	872 11 06-14	Bolt, Carriage 3/8-16 x 2-3/4	55	532 14 00-84	Arm, Idler	118	873 68 06-00	Nut, Centerlock 3/8-16 UNC
18	872 14 05-05	Bolt, Carriage 5/16-18 x 5/8	56	532 12 20-52	Spacer, Retainer	119	734 11 72-01	Washer 3/8 x 7/8 x 14
19	532 13 28-27	Bolt Shoulder 5/16-18 Thd Form	58	532 14 00-86	Spring Torsion Brake	120	819 17 15-12	Washer 17/32 x 15/16 x 12 Ga.
20	532 13 68-88	Baffle	59	532 14 10-43	Guard Idler TUV	121	532 14 37-23	Bracket Extruded Gauge Wheel
21	873 68 05-00	Nut Crownlock 5/16-18 UNC	60	532 14 59-89	Screw Truss Hd Phil 10-24 x 5/8	---	532 13 07-94	Asm. Mandrel (includes key nos. 8-10, 12-15, 31 et 33)
22	532 13 47-53	Stiffener, Bracket	64	532 13 93-28	Guard Deflector Mower 42" TUV	---	532 14 47-83	Deck, Mower, Complete (Order separately noseroller and gauge wheel components key nos. 90-95 and 111-121)
23	532 13 12-67	Bracket, Deflector	67	532 10 69-33	Knob Rd 1/2-13 Plstc Thds Blk V-Belt, Mower			
24	532 10 53-04	Cap, Sleeve	68	531 02 06-70	Rod, Clutch, Primary, with Nibs			
25	532 12 37-13	Spring, Torsion, Deflector	71	532 14 24-27	Spring, Extension, Return			
26	532 11 04-52	Washer, Lock	72	532 13 18-70	Arm, Clutch, Secondary			
27	532 13 94-50	Deflector, Clipping TUV	73	532 12 78-47	Washer 25/32 x 1-5/8 x 16 Ga.			
28	734 11 63-01	Washer 11/32 x 5/8 x 16 Ga.	74	532 12 17-48	Ring, Klip			
29	532 13 14-91	Rod, Hinge	75	812 00 00-29	Bolt, Shoulder 3/8-16 UNC x 1.44			
30	532 13 87-76	Screw Hex Thdrol	76	532 12 89-03	Keeper, Spring			
31	532 12 99-63	Washer, Spacer	77	532 12 78-45	Arm, Clutch, Primary			
32	532 12 98-61	Pulley, Mandrel	78	532 14 01-79	Bushing, Large, Brass			
33	532 13 72-66	Nut Lock 9/16	79	532 12 74-98	Spring Clutch Mower			
34	872 11 06-10	Bolt	80	532 12 87-59	Nut Hex Jam 3/8-16			
35	532 13 38-35	Fastener Christmas Tree	81	873 22 06-00	Trunnion Adj 94			
36	532 13 14-94	Pulley, Idler, Flat	82	532 14 20-28	Washer Sintered			
37	734 11 72-01	Washer 13/32 x 13/16 16 Ga.	83	532 12 09-58				

O

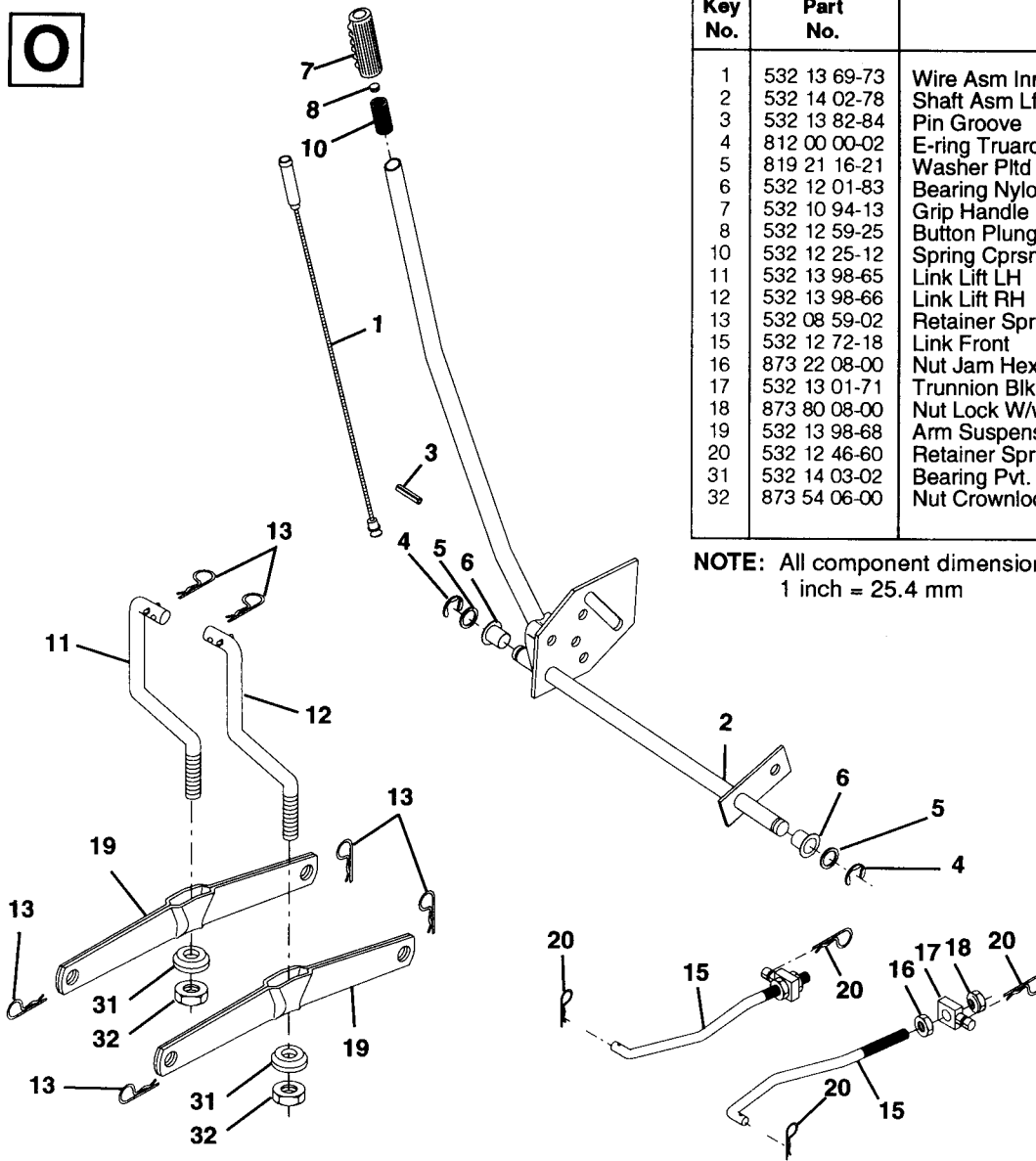

Key No.	Part No.	Description
1	532 13 69-73	Wire Asm Inner W/Plunger
2	532 14 02-78	Shaft Asm Lft LH
3	532 13 82-84	Pin Groove
4	812 00 00-02	E-ring Truarc #5133-62
5	819 21 16-21	Washer Pltd 21/32 X 1 X 21 Ga
6	532 12 01-83	Bearing Nylon
7	532 10 94-13	Grip Handle Bicycle Matte
8	532 12 59-25	Button Plunger
10	532 12 25-12	Spring Cprsn
11	532 13 98-65	Link Lift LH
12	532 13 98-66	Link Lift RH
13	532 08 59-02	Retainer Spring
15	532 12 72-18	Link Front
16	873 22 08-00	Nut Jam Hex 1/2-13 Unc
17	532 13 01-71	Trunnion Blk Zinc
18	873 80 08-00	Nut Lock W/wsh 1/2-13unc
19	532 13 98-68	Arm Suspension Rear
20	532 12 46-60	Retainer Spring
31	532 14 03-02	Bearing Pvt. Lift Spherical
32	873 54 06-00	Nut Crownlock 3/8-24

NOTE: All component dimensions given in U.S. inches
1 inch = 25.4 mm

R

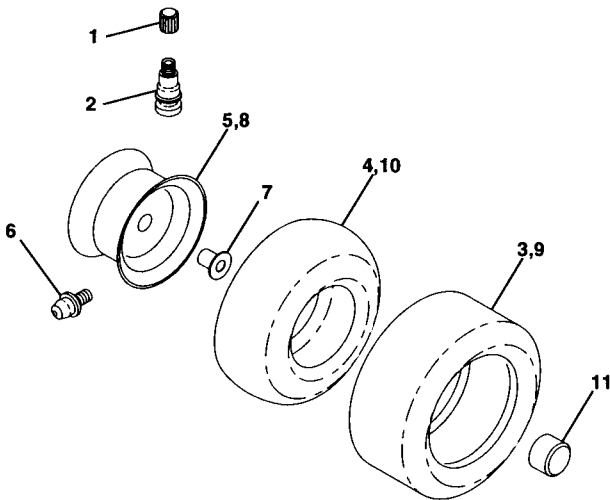

Key No.	Part No.	Description
1	532 05 91-92	Cap Valve Tire
2	532 06 51-39	Stem Valve
3	533 30 11-40	Tire F Ts 15 X 6 0 - 6 Service
4	532 05 99-04	Tube Front (Service Item Only)
5	532 10 67-32	Rim Asm 6" front Yellow Service
6	532 00 02-78	Fitting Grease (Front Wheel Only)
7	532 00 90-40	Bearing Flange (Service Item Only)
8	532 12 51-22	Rim Asm 8" rear Yellow Service
9	532 12 20-82	Tire R Ts 18x9 5-8 C Service
10	532 00 71-52	Tube Rear (Service Item Only)
11	532 10 47-57	Cap Axle Blk 1 50 X 1 00

NOTE: All component dimensions given in U.S. inches
1 inch = 25.4 mm