

# SW45PRE - 45" Tow Behind Lawn Sweeper

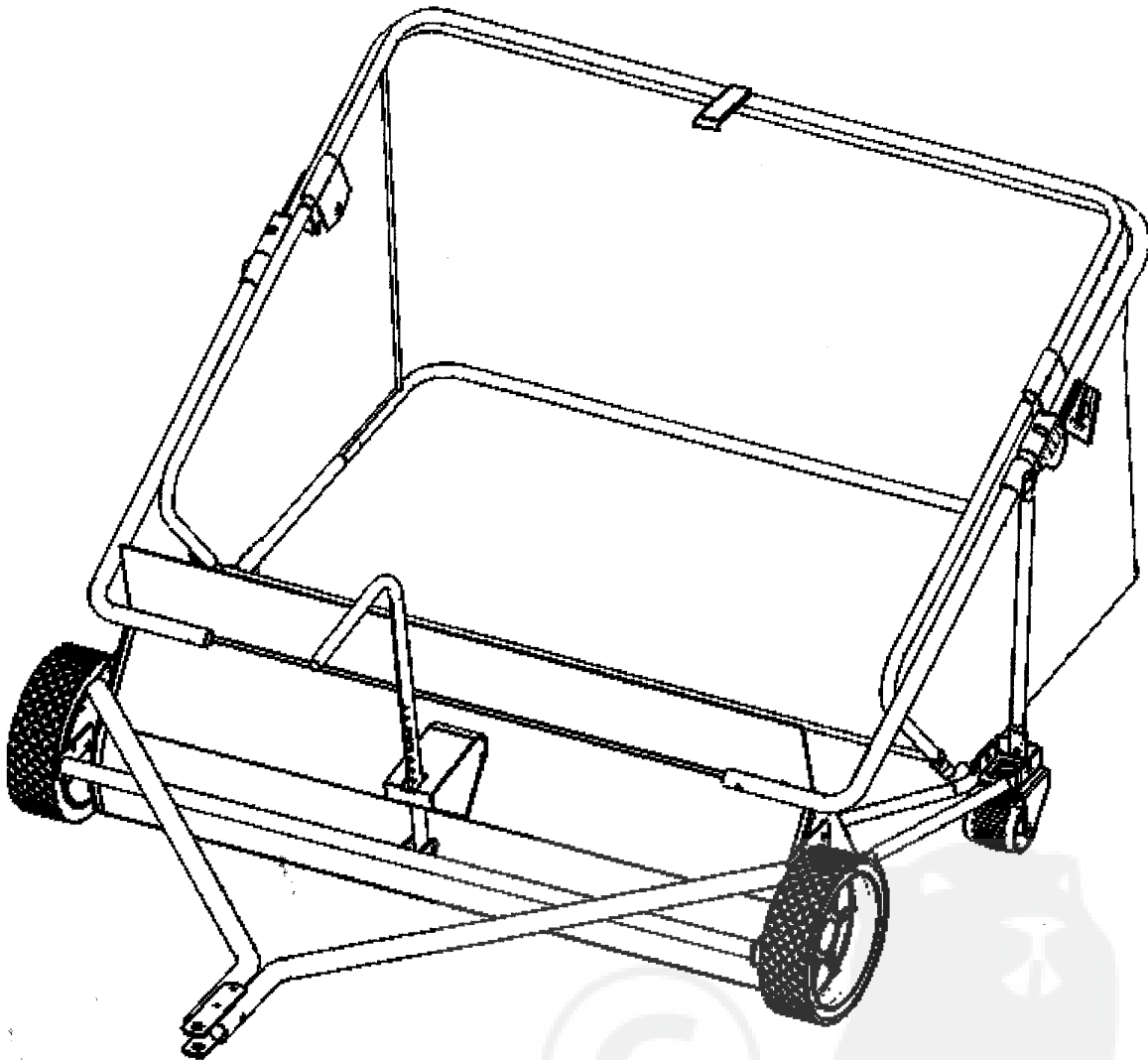

## Owner's Manual and Parts List Precision Products, Inc.

1/04

### Customer Service & Warranty Information

Parts list on back page

**PLEASE DO NOT RETURN THIS MERCHANDISE TO THE STORE. CALL US AND WE WILL TAKE CARE OF ANY PROBLEM YOU MIGHT HAVE WITH THIS PRODUCT. Phone (800) 225 - 5891 EXT. #204**

When ordering parts always give model number, part description & part number.

**Send To:** Precision Products, Inc.  
Parts Division  
316 Limit Street  
Lincoln, IL 62656

**Phone** (217) 735-1590  
**Fax** (217) 735-2435

#### LIMITED WARRANTY

This unit is warranted against defects in materials and workmanship to the original purchaser, under normal use and service, for a period of ninety (90) days from date of sale. During the Warranty Period, we will repair or replace at our option free of charge to the original purchaser, any part of the Unit that our examination shows to be defective in workmanship or materials. This Warranty **Does Not** apply to damage caused by misuse, abuse, neglect, accident, normal wear, or alterations by unauthorized persons.

Your new SW45PRE lawn sweeper is precision manufactured using the finest in tools and materials. Although it is ruggedly constructed, do not subject this unit to misuse. Be sure to wipe off your unit after each use. Store in a dry place out of direct sunlight. Do not permit the lawn sweeper to stand in the hot sun, unless it is in actual use.

You will find many work saving uses for your lawn sweeper. Use it early in the spring to give your lawn a good healthy scrubbing. Use it throughout spring and summer before and after mowing. Sweeping your lawn before mowing stands the grass up for a clean, even cut. It also allows increased protection to your mower by removing sticks, stones and nuts, which might damage the blade(s) on your mower. Sweeping your lawn after mowing will whisk away unsightly grass clippings - leaving your lawn velvety smooth.

<p><b>Tools Required For Assembly:</b>                  One (1) - Pair Pliers (Needle Nose)                  Two (2) - 7/16" Wrenches                  Two (2) - 1/2" Wrenches</p>	<p><b>Prior To Assembly:</b>                  Remove all Sweeper Parts from carton. Make sure all parts and assemblies are present before assembly. If any parts are missing, contact Customer Service (contact information on back sheet) immediately for assistance.                  Lay out all parts and have tools ready.</p>
--	---

**Parts List Of SW45PRE**

**Assembly Parts List Description**

Ref.	Description	Qty.
A	Hamper Assembly	1
B	Chassis Assembly	1
C	Pivot Frame Assembly	1
D	Bottom Hamper Cross Tube	1
E	Height Adjustment Tube	1
F	Hitch Arms	2
G	Hamper Support Rods	2
H	Clevis Plates	2
I	Hamper Dump Rope	1
J	Wind Apron	1

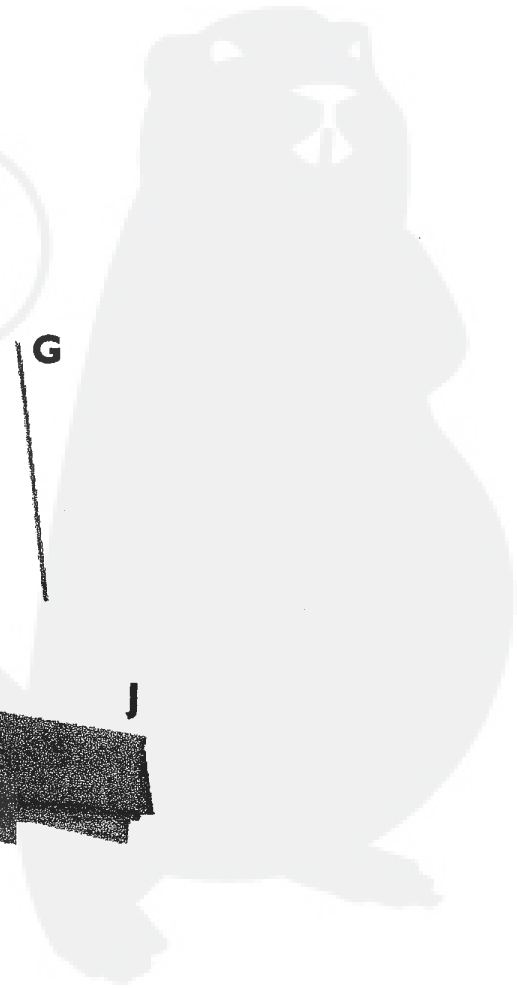
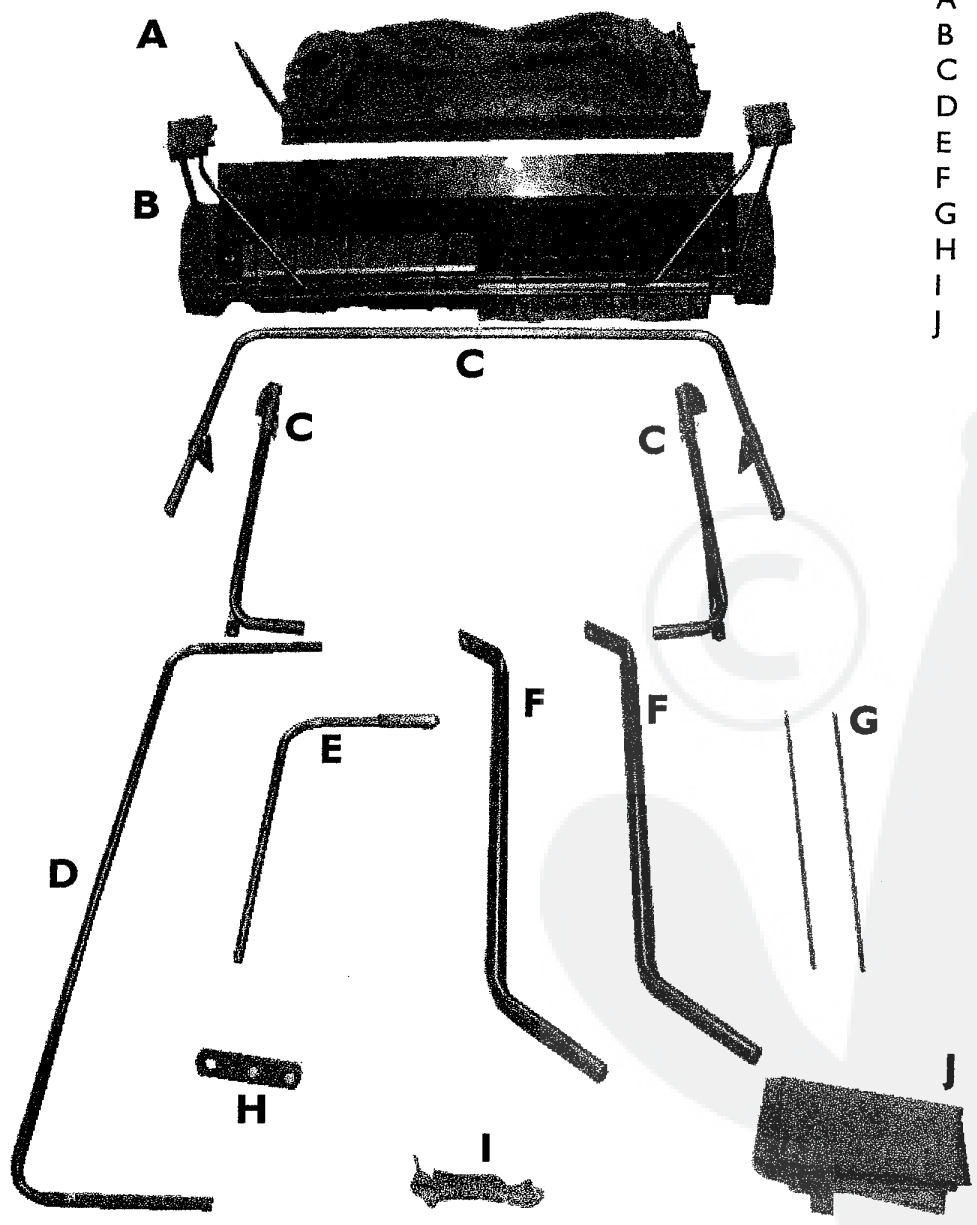

NOTE: ALL REFERENCES TO "RIGHT" AND "LEFT" DIRECTIONS ARE IN REFERENCE TO POSITION BEHIND SWEEPER.

**Step 1**

Attach the Pivot Stand Brace (pre-attached to Sweeper Chassis) to the Sweeper Chassis using a 1/4" x 1-1/4" Bolt. Repeat this step for the other Pivot Stand Brace. Fig. 1

Lock the Pivot Stand Tube in place by inserting a 1/4" x 1/2" Bolt through the Pivot Stand Tube and Sweeper Assembly and securing it with a 1/4" Lock Nut. Fig. 1

Tighten the nut on the pre-attached 5/16" Bolt if needed.

**Step 2**

Attach both Bottom Pivot Frame Assemblies to both right and left sides on the front of the Sweeper Chassis using two 1/4" x 1-1/2" Hex Head Bolts and two 1/4" Lock Nuts. Fig.2 (Right Bottom Pivot Frame Assembly Shown) Next, bolt the Vertical Pivot Tube on the Pivot Frame Assembly to the Caster Assembly using two 5/16" x 1/2" Bolts and two 5/16" Lock Nuts. Fig.2

Remove the bottom 1/4" x 1-1/2" Bolts (on both Bottom Pivot Frame Assemblies, Fig. 3) and insert the Top Pivot Frame Assembly into both sides. Fig.4 The tube ends will attach inside the Plastic Hamper Hinge. Re-insert the removed 1/4" x 1-1/2" Bolts to secure the Top Pivot Frame Assembly. Attach the Catch Bracket on top of the Top Pivot Frame Assembly Tube using the (pre-attached) 1/4" x 1-1/2" Bolt and 1/4" Lock Nut. Fig 5

**Fig. 1**

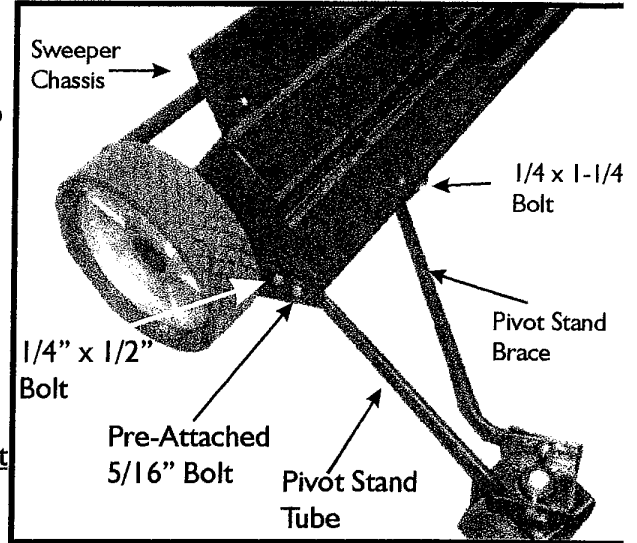

**Fig. 2**

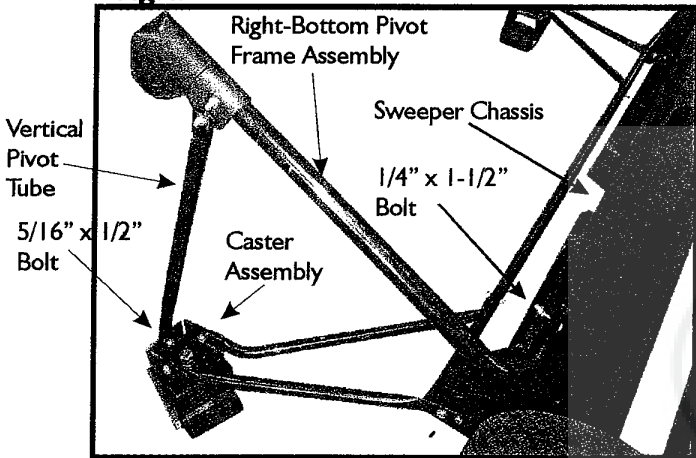

**Fig. 3**

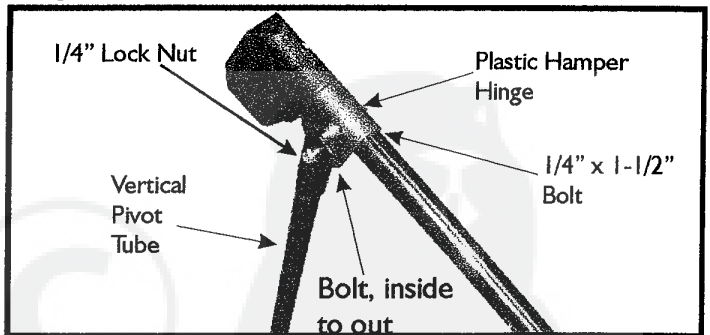

**Fig. 5**

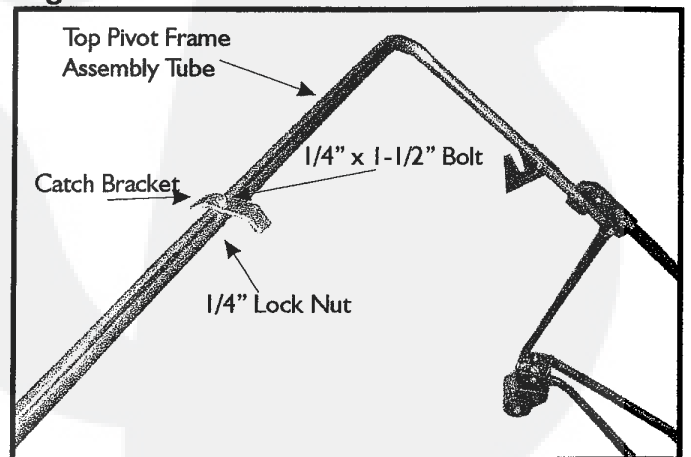

**Fig. 4**

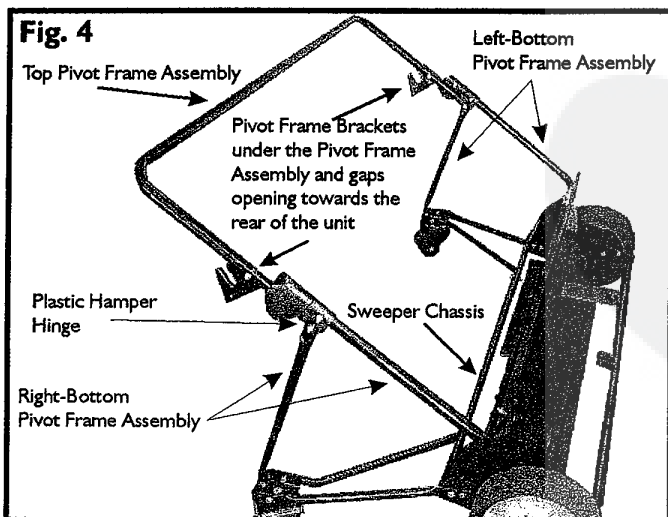

### Step 3

Attach both Hitch Arms together using one 5/16" x 3-1/4" Hex Head Bolt and one 5/16" Lock Nut. Fig. 6 Do not tighten this bolt yet.

Attach both Clevis Plates to the end of the Hitch Arms. One 5/16" x 2-1/4" Hex Head Bolt is attached in front of the 5/16" x 3-1/4" Hex Head Bolt that was used to connect the Hitch Arms. The other 5/16" x 2-1/4" Hex Head Bolt needs to be behind the Hitch Arm Bolt. Tighten the Hitch Arm bolt then the two Clevis Plate Bolts. Fig. 7 This arrangement keeps the Clevis Plates from slipping off the end of the Hitch Arms while in use.

Fig. 6

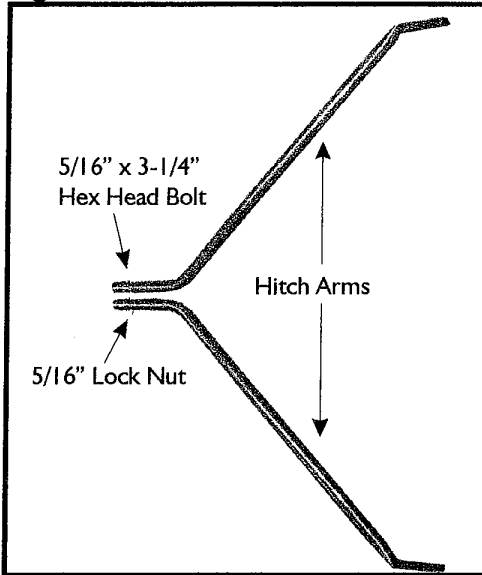
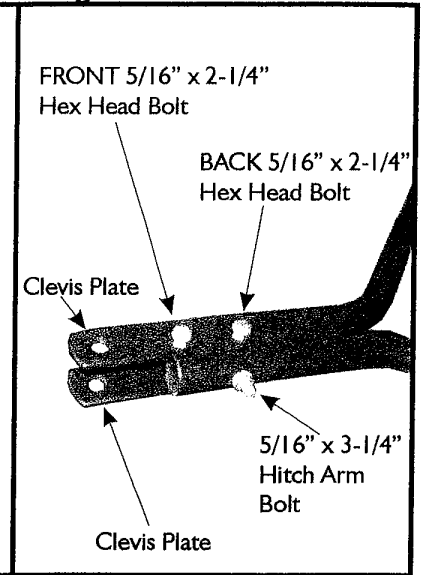

Fig. 7



### Step 4

Attach the hitch arm assembly to the front of the Sweeper Chassis Assembly using two 5/16" x 3/4" Hex Head Bolts and two 5/16" Lock Nuts. Fig. 8 If you have trouble attaching the Hitch Arm Assembly, try loosening the 5/16" x 3-1/4" Hex Head Bolt in order for the Hitch Arms to spread apart easier.

Fig. 8

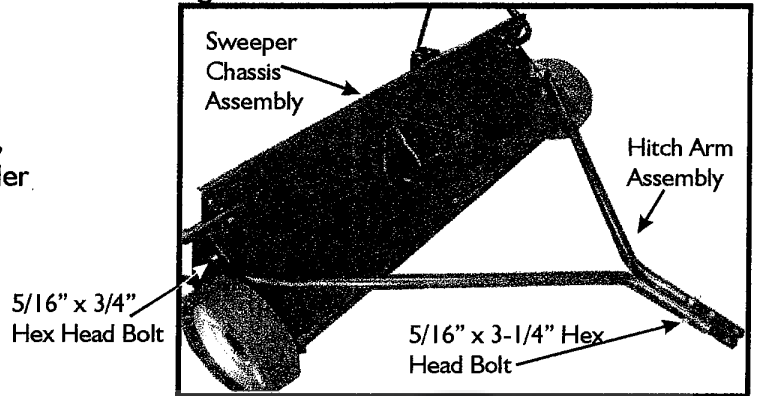

### Step 5

Insert the bottom of the Height Adjustment Tube through the hole in the front of the Sweeper Chassis. Be sure the Handle Grip on the Height Adjustment Tube is facing forward. Attach the bottom of the Height Adjustment Tube to the Bumper Assembly using a 5/16" x 2" Hex Head Bolt and a 5/16" Lock Nut. Fig. 9

Attach one end of the Spring to the notch on the height adjustment bracket. Pull the Spring around and behind the Height Adjustment Tube. Attach the other end of the Spring to the opposite notch. Fig. 10

Fig. 9

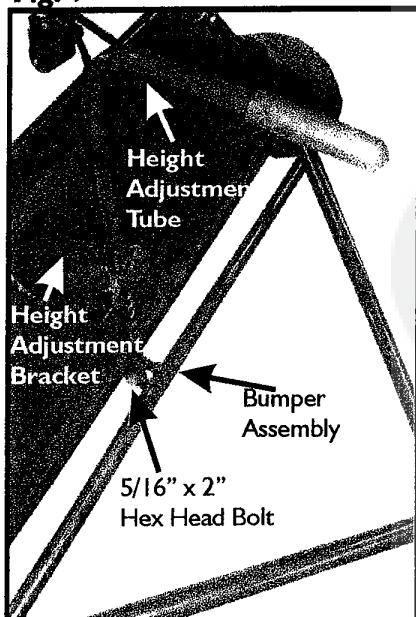
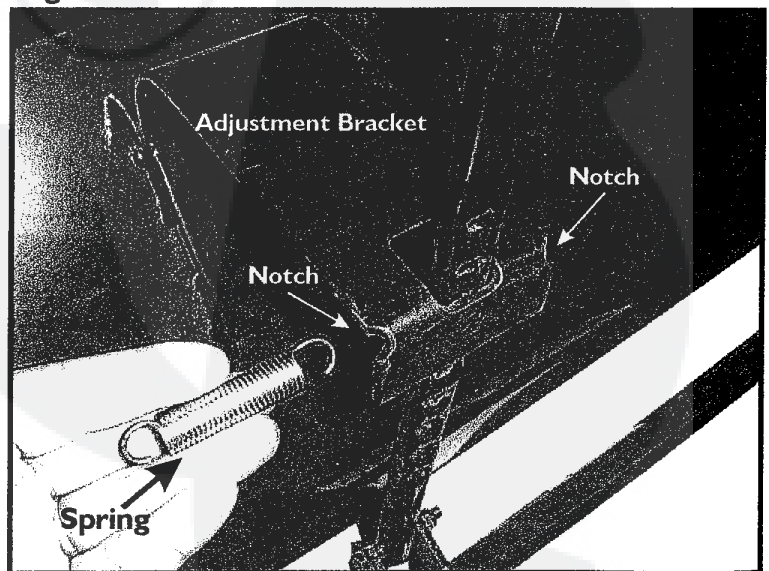

Fig. 10



**Step 6**

For Packaging purposes the Top Side Hamper Tubes (2 - one each side) are put on upside-down. Remove the nut on each end of the Tie Rod and re-attach the Top Side Hamper Tubes as shown in illustration. Fig. 11

Insert The Top Side Hamper Tube into the end of the Top Hamper Cross Tube. There is a spring button lock on the Top Side Hamper Tube that will secure these two tube assemblies together. Fig. 11

Attach the Bottom Hamper Cross Tube to the two (one each side) Bottom Side Hamper Tubes. The two holes in the Bottom Hamper Cross Tube need to face out as shown in the illustration. Fig. 12 These holes are for the Hamper Support Rods, attached later in this assembly.

Push the Bottom Hamper Cross Tube down while pulling up on the Top Hamper Cross Tube, this creates the extended Hamper Assembly. Fig. 12

**Fig. 11**

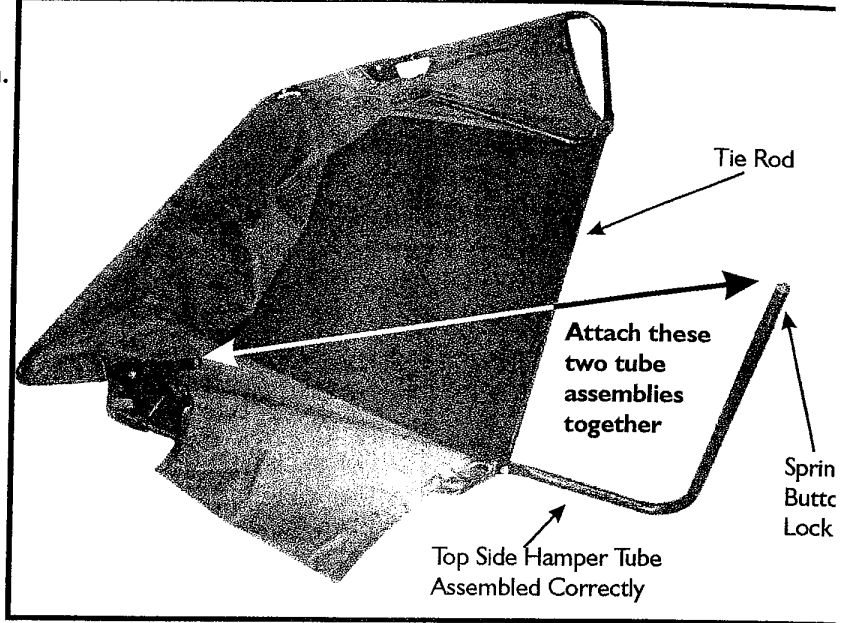

Finally, insert one end of the Hamper Support Rod into the Top Hamper Cross Tube hole and the other end of the Hamper Support Rod into the Bottom Hamper Cross Tube hole. Fig. 13 Repeat this process for the other Hamper Support Rod on the other side of the Hamper Assembly.

**Fig. 12**

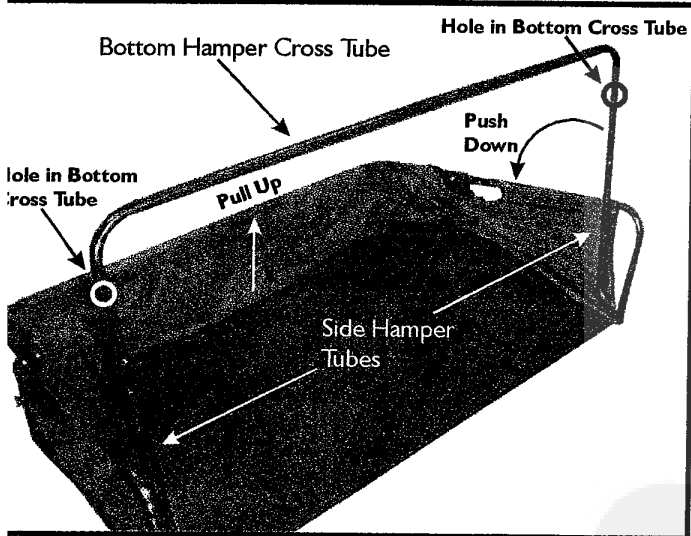

**Fig. 13**

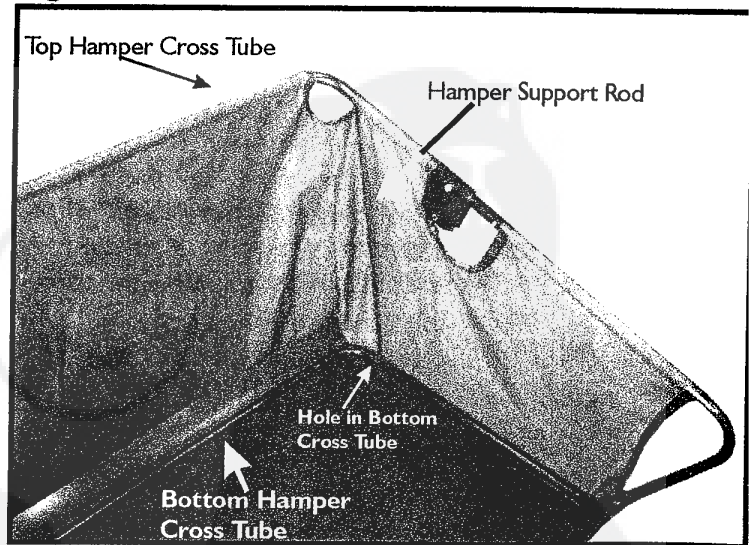

Attach the optional Wind Apron to the outside tubes towards the front of the Hamper Assembly. Fig. 14

The Wind Apron helps keep debris from blowing out of the Hamper Assembly while the unit is in use.

**Fig. 14**

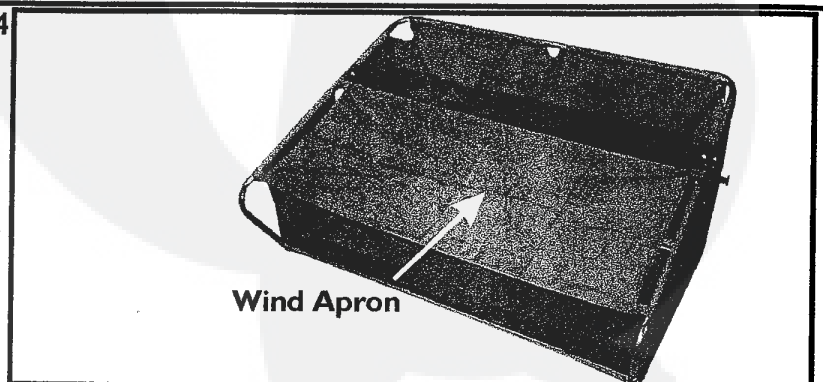

### Step 7

Insert the Hamper Dump Rope through center hole on the Sweeper Chassis Assembly. Next, lay the Hamper Dump Rope behind the sweeper. Fig. 15

Loosen the bolts holding both right and left Hamper Pivot Bracket Assemblies. Fig. 14  
Install the Hamper Assembly onto the Pivot Frame Assembly. The Hamper Pivot Bracket Assemblies fit inside the slots on both Frame Pivot Brackets. Tighten both bolts after Hamper installation. Fig. 16

The Hamper Dump Rope needs to go under and up the back side of the Hamper Assembly for proper dumping operation. Tie the Hamper Dump Rope end to the center of the Top Hamper Cross Brace. Fig. 17

Fig. 15

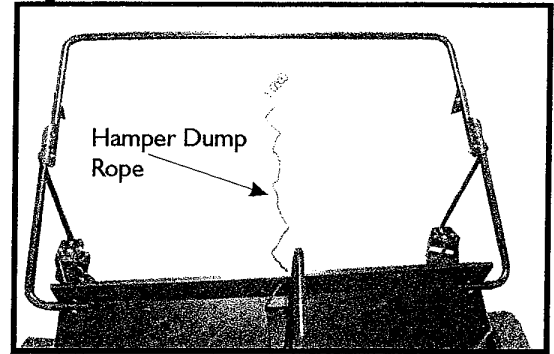

Fig. 16

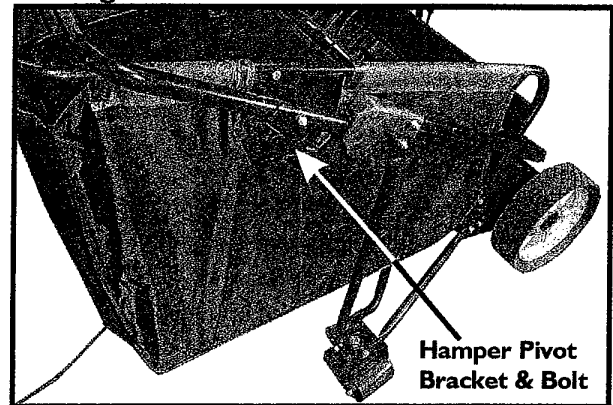
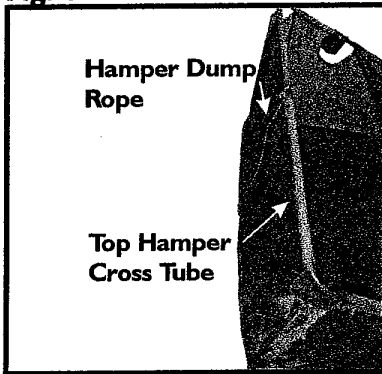

Fig. 17



### STORAGE:

Remove both Hamper Support Rods on the inside of the Hamper.

Next, simply release both Cross Tube Locks and fold the Hamper down.

You can also pull the Hitch Arm Assembly up and tie it off through the Clevis Plates with the Hamper Dump Rope.

Cross Tube Lock

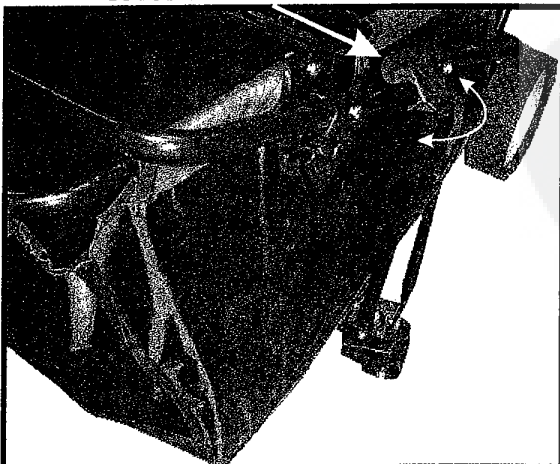

# Hardware for SW45PRE & SW38PRE 11/03

5/16" x 3-1/4" Hex Head Bolt (1), STEP 3

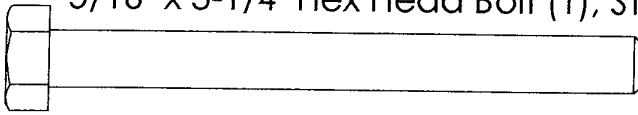

5/16" x 2-1/4" Hex Head Bolt (2), STEP 3

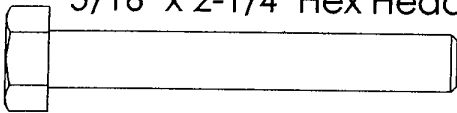

5/16" x 2" Hex Head Bolt (1), STEP 5

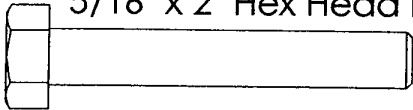

5/16" Lock Nut



5/16" x 3/4" Hex Head Bolt (2), STEP 4

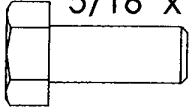

Spring (1), STEP 5



5/16" x 1/2" Hex Head Bolt (2), STEP 2

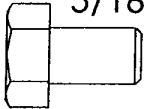

NOTE: SPRING MIGHT  
ALREADY BE ATTACHED  
TO UNIT.

1/4" x 1-1/2" Hex Head Bolt (2), STEP 2

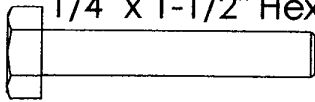

1/4" x 1-1/4" Hex Head Bolt (2), STEP 1

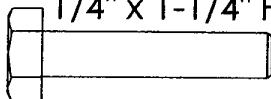

1/4" Lock Nut



1/4" x 1/2" Hex Head Bolt (2), STEP 1

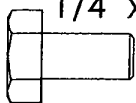

## OPERATION:

**Brush Adjustment:** Your new trailer-sweeper is equipped with a handy, "From Your Seat" brush adjustment. To raise, push Height Adjustment Tube back and down until desired sweeping height is attained. To lower, push Height Adjustment Tube back and pull up to desired sweeping height (See Fig 18). For best results, brushes should barely touch the top of the grass blades. Brushes should be raised when transporting the unit to and from sweeping area.

**Sweeping Speed:** For best results, rider/tractor should travel at a 3 to 5 M.P.H. range.

**Dumping:** Simply pull the Hamper Dump Rope forward to empty debris (See Fig. 19). Slowly ease the Hamper Dump Rope back, keeping even pressure, until the Hamper returns back down.

**CAUTION: DO NOT ALLOW THE HAMPER DUMP ROPE TO HAVE TOO MUCH SLACK IN IT WHEN OPERATING. THE ROPE CAN GET CAUGHT IN THE BRUSHES CAUSING INJURIES.**

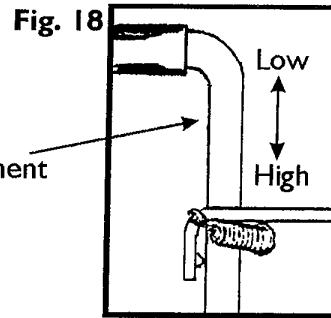
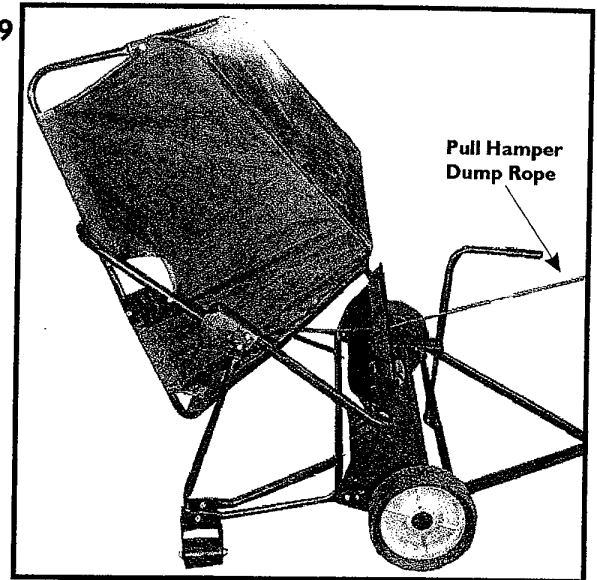

Fig. 19



## MAINTENANCE:

**Lubrication:** Remove wheel by removing plastic hubcap and snap ring. Apply a light multipurpose grease to wheel gear and pinion gear. NOTE: DO NOT allow grease to enter center of pinion gear. Lubricate it the beginning of each season or more often as conditions dictate. See Fig. 20.

Remove pinion gear and oil pawl with SAE #20 or equivalent. Do not apply grease or heavy oil to pawl. This causes the pawl to stick and operate erratically. When installing pinion and pawl, refer to Fig 21 for correct position.

Apply SAE #20 oil or equivalent to brush axle bearings twice a season. Oil Hamper pivot pins occasionally to prevent rust and insure easy dumping.

### Brush Replacement:

Place brush strips in slots of brush disc so shorter supporting bristles are away from brush sweeping rotation. Secure at each disc with three holder springs. Feed spring through hole in disc. Place upper point into bristles with point next to disc. With pliers, rasp springs, turn and raise upward so lower point is secured on backing of second brush. Tap each end of spring with pliers to make certain that the points are completely down to bristles. See Fig. 22

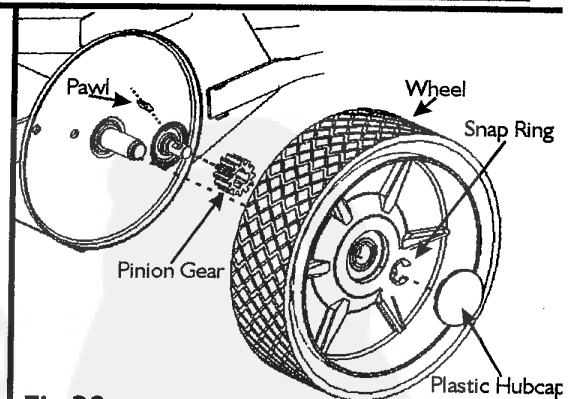
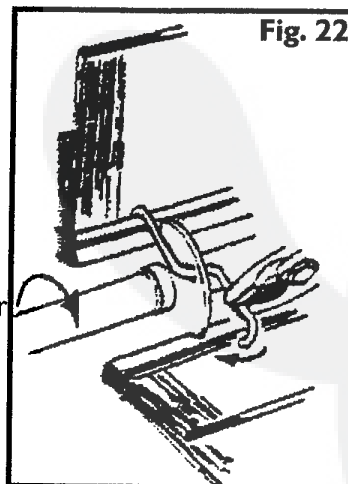

Fig. 20

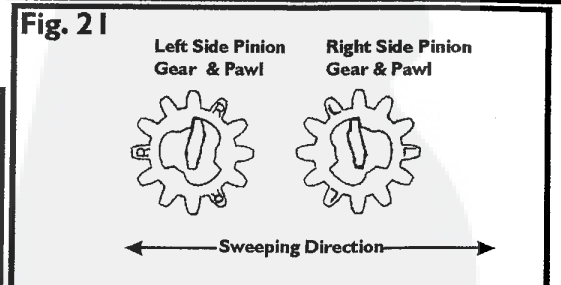
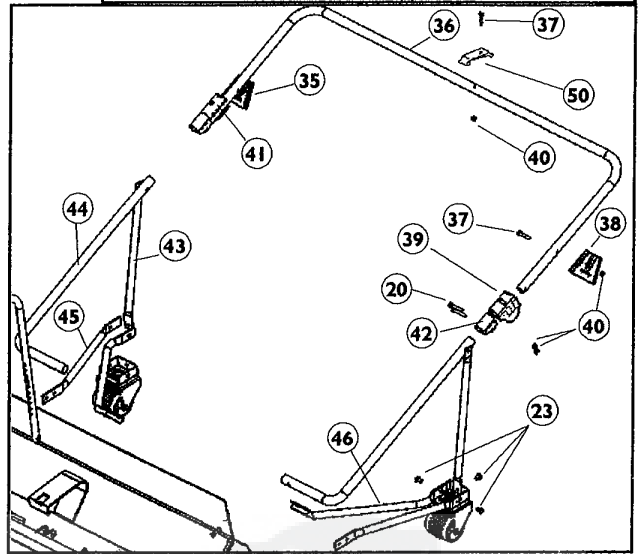
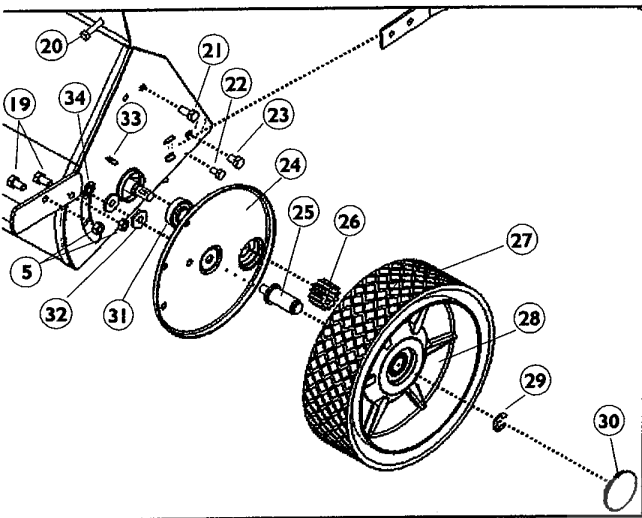
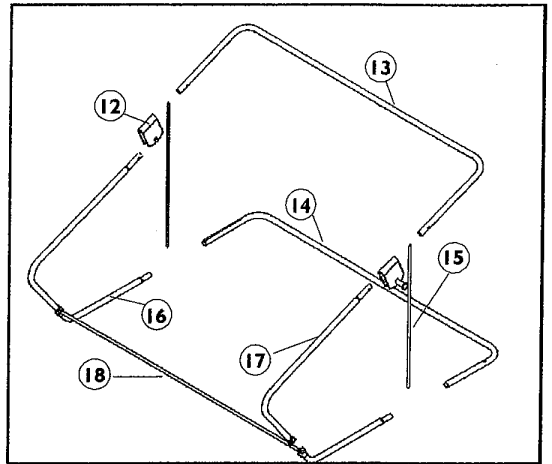
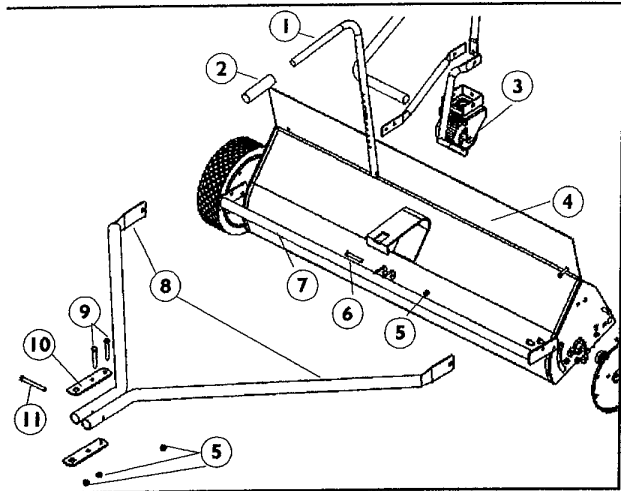

Fig. 21



# Parts List for SW45PRE



Ref #	Part #	Part Description	Qty.	Ref #	Part #	Part Description	Qty.
1	1745	Height Adjustment Tube	1	34	1773	3/8" Pilot Nut	1
2	1746	Handle Grip	1	35	1774	RH Hamper Pivot Bracket	1
3	1747	Caster Assembly	2	36	1775	Top Pivot Cross Tube	1
4	1748	Sweeper Chassis	1	37	6129	1/4" x 1-1/2" Hex Head Bolt	3
5	1749	5/16" Lock Nut	19	38	1776	LH Hamper Pivot Bracket	1
6	4041	5/16" x 2" Hex Head Bolt	1	39	1777	LH Cross Tube Lock	1
7	1750	Bumper Assembly	1	40	1778	1/4" Lock Nut	13
8	1751	Hitch Arms	2	41	1779	RH Cross Tube Lock	1
9	1752	5/16" x 2 1/4" Hex Head Bolt	2	42	1780	Plastic Hamper Hinge	2
10	1753	Clevis Plate	2	43	1781	Vertical Pivot Tube	2
11	1754	5/16" x 3-1/4" Hex Head Bolt	1	44	1782	Pivot Support Tube	2
12	1755	Hamper Pivot Bracket Assembly	2	45	1783	Pivot Stand Tube	2
13	1756	Top Hamper Cross Tube	1	46	1784	Pivot Stand Brace	2
14	1757	Bottom Hamper Cross Tube	1	47	1785	Brush Strip	6
15	1758	Hamper Support Rod	2	48	1786	Brush Spring	18
16	1792	Bottom Hamper Side Tube	2	49	1787	Bush/Axle/Disc Assembly	1
17	1759	Top Side Hamper Tube	2	50	1795	Catch Bracket	1
18	1760	Tie Rod	1	**PARTS NOT ILLUSTRATED			
19	1761	5/16" x 5/8" Hex Head Bolt	4	**	1788	Hamper (Material)	1
20	1065	1/4" x 1-3/4" Hex Head Bolt	2	**	1789	Wind Apron	1
21	1248	5/16" x 3/4" Hex Head Bolt	2	**	1790	Hamper Dump Rope	1
22	1647	1/4" x 1/2" Hex Head Bolt	2	**	1282	Spring	1
23	1762	5/16" x 1/2" Hex Head Bolt	8				
24	1763	Wheel Shield	2				
25	1764	Stub Axle	2				
26	1765	Pinion Gear	2				
27	1766	10" Tire	2				
28	1767	10" Die Cast Wheel	2				
29	1768	5/8" E Type Snap Ring	2				
30	1769	Plastic Hub Cap	2				
31	1770	Flange Bearing	2				
32	1771	3/8" Lock Nut	2				
33	1772	Pinion Pawl	2				

