

# PARTS LIST FOR LAWN ROLLERS: PLR1824 PLR1836

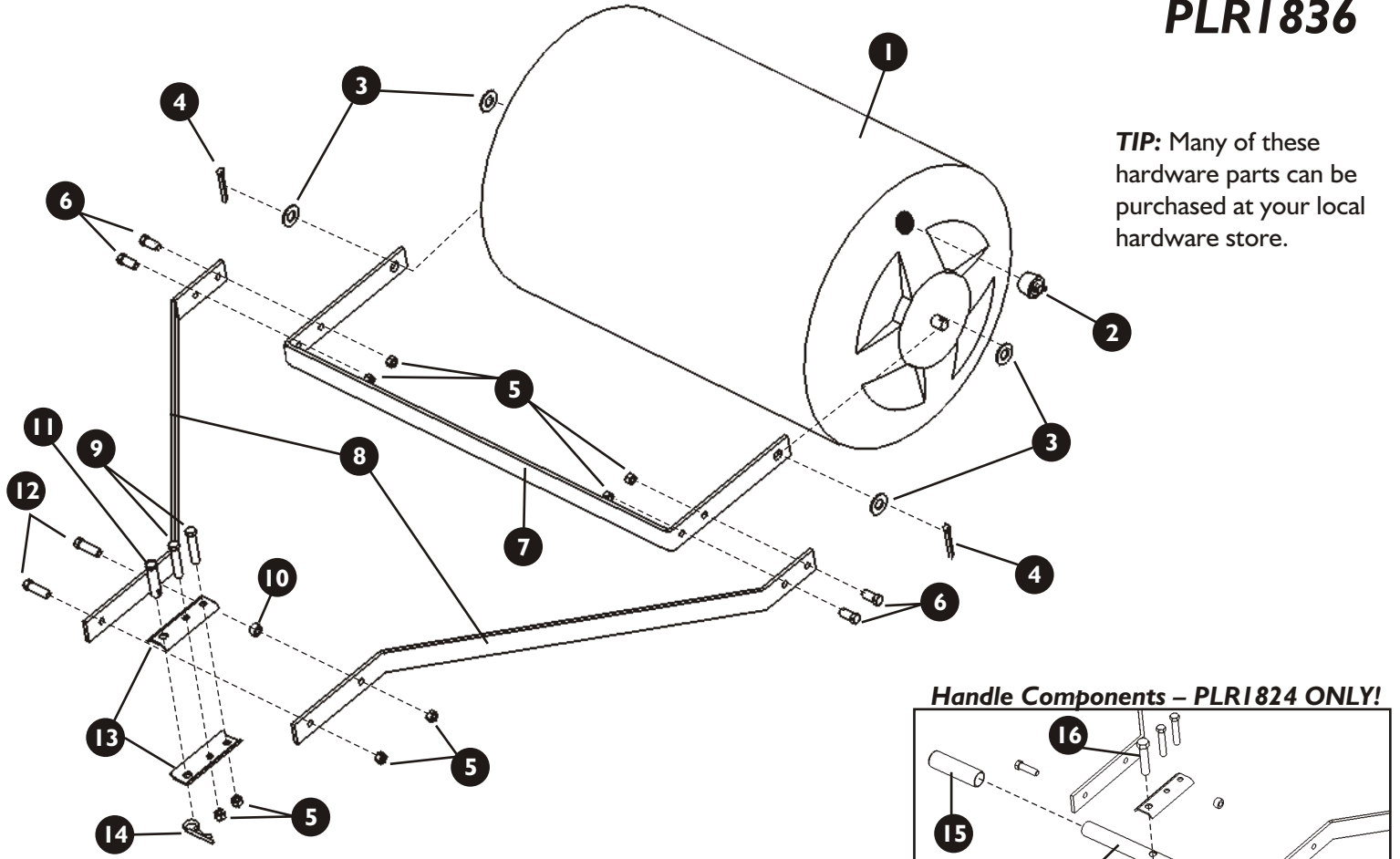

**TIP:** Many of these hardware parts can be purchased at your local hardware store.

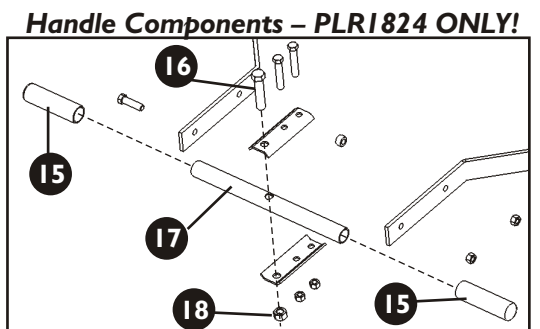

**PLEASE DO NOT RETURN THIS MERCHANDISE TO THE STORE. CALL US AND WE WILL TAKE CARE OF ANY PROBLEM YOU MIGHT HAVE WITH THIS PRODUCT.**  
Phone (800) 225-5891 EXT. #204

# Precision Products, Inc.

## Precision Pro Plastic Lawn Roller

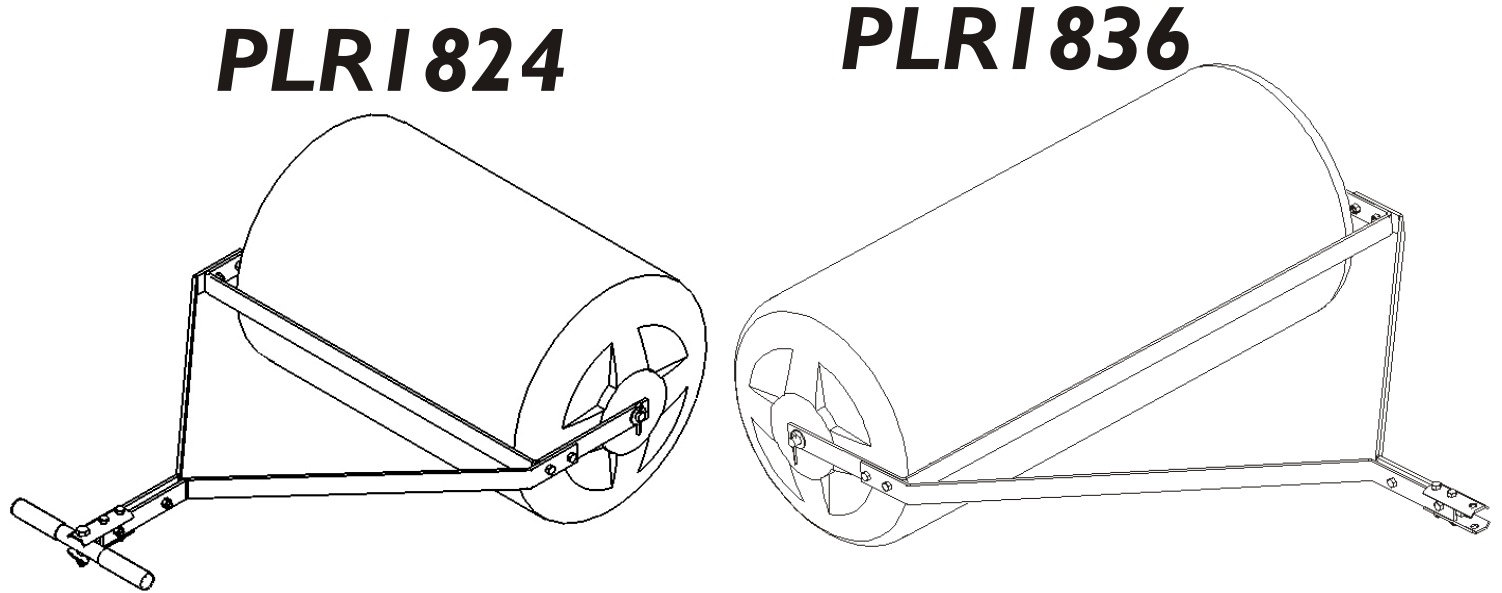

**Tools Required for Assembly:**  
1- Pair of Pliers  
2 - 9/16" Wrenches  
2 - 3/4" Wrenches

PLR1824 Parts List			
Ref No	Parts No	Description	Qty
1	3263	Roller Body	1
2	1956	Expansion Plug	1
3	1646	5/8" Flat Washer	4
4	2576	3/16" Cotter Pin	2
5	3039	3/8" Lock Nut	8
6	1974	3/8" x 1" Hex Head Bolt	4
7	3264GY	Center Brace	1
8	3265GY	Hitch Side Bar	2
9	3255	3/8" x 2-1/4" Hex Head Bolt	2
10	3254	3/8" x 3/8" Spacer	1
11	3256	Clevis Pin 1/2" x 2-1/4"	1
12	1806	3/8" x 1-1/2" Hex Head Bolt	2
13	3257GY	Clevis Plate	2
14	1042	#14 Hitch Pin Clip	1
15	3042	1" Handle Grip	2
16	3268	1/2" x 2-1/2" Hex Head Bolt	1
17	3266	Handle Tube	1
18	2311	1/2" Lock Nut	1

PLR1836 Parts List			
Ref No	Parts No	Description	Qty
1	3250	Roller Body	1
2	1956	Expansion Plug	1
3	1646	5/8" Flat Washer	4
4	2576	3/16" Cotter Pin	2
5	3039	3/8" Lock Nut	8
6	1974	3/8" x 1" Hex Head Bolt	4
7	3251GY	Center Brace	1
8	3252GY	Hitch Side Bar	2
9	3255	3/8" x 2-1/4" Hex Head Bolt	2
10	3254	3/8" x 3/8" Spacer	1
11	3256	Clevis Pin 1/2" x 2-1/4"	1
12	1806	3/8" x 1-1/2" Hex Head Bolt	2
13	3257GY	Clevis Plate	2
14	1042	#14 Hitch Pin Clip	1

**STEP 1**

Place a 5/8" Flat Washer (3) over the axle on the Roller Body (1). Do this for both ends of the Roller Body. Fig. 1

Next, place one end of the Center Brace (7) over one side of the axle then the opposite side. NOTE: you will have to pull (spread out) on one end of the Center Brace to get it to go over the axle. Fig. 2

Place another 5/8" Flat Washer (3) over the axle on the Roller Body (outside the Center Brace) on each end. Fig. 1

Insert a 3/16" Cotter Pin(4) into the hole on the axle and spread the legs of the pin to secure into place. Repeat this procedure for the other side of the axle. Fig. 1

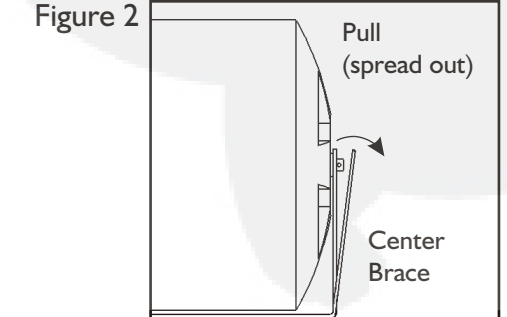
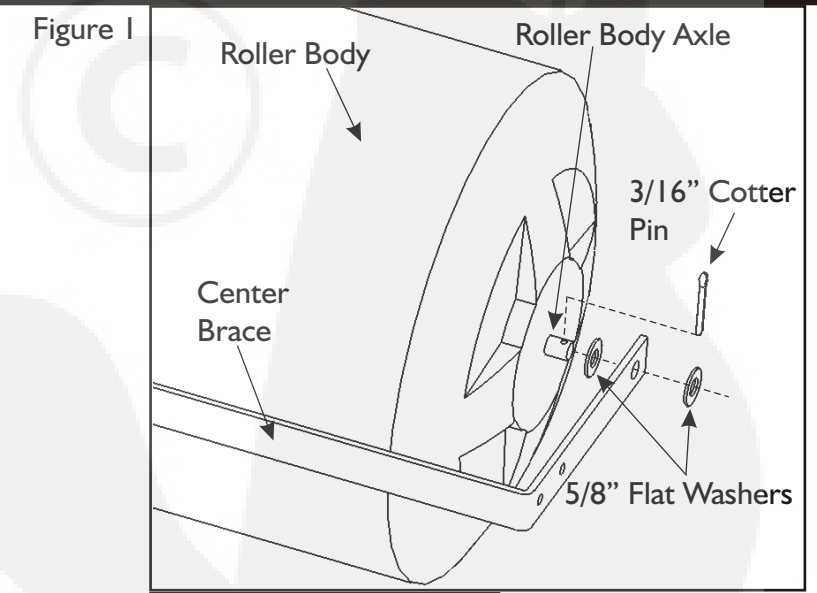

**HOW TO ORDER**

**REPLACEMENT PARTS:**  
When ordering parts always give model number, part number and part description.

**Send To:** Parts Division  
316 Limit Street  
Lincoln, IL 62656

**Phone (800) 225-5891**  
(217) 735-1590 Ext. 204  
**FAX (217) 735-2435**

## STEP 2

Figure 3

Attach the Hitch Side Bars (8) to the Center Brace, using 3/8" x 1" Hex Head Bolts (6) and 3/8" Lock Nuts (5). Fig. 3

Insert the 3/8" x 3/8" Spacer (10) between the two Hitch Side Bars. The Spacer needs to be attached to the second hole back from the front of the Hitch Side Bars. Secure the Spacer in place by inserting a 3/8" x 1-1/2" Hex Head Bolt (12) through one Hitch Side Bar then the 3/8" x 3/8" Spacer and the other Hitch Side Bar. Thread a 3/8" Lock Nut (5) onto the bolt end. **Note: Do not tighten this bolt and nut yet.** Fig. 3

Insert the other 3/8" x 1-1/2" Hex Head Bolt (12) through the first hole on the Hitch Side Bar. Thread a 3/8" Lock Nut (5) onto the bolt end. **Note: Do not tighten this bolt and nut yet.** Fig. 3.

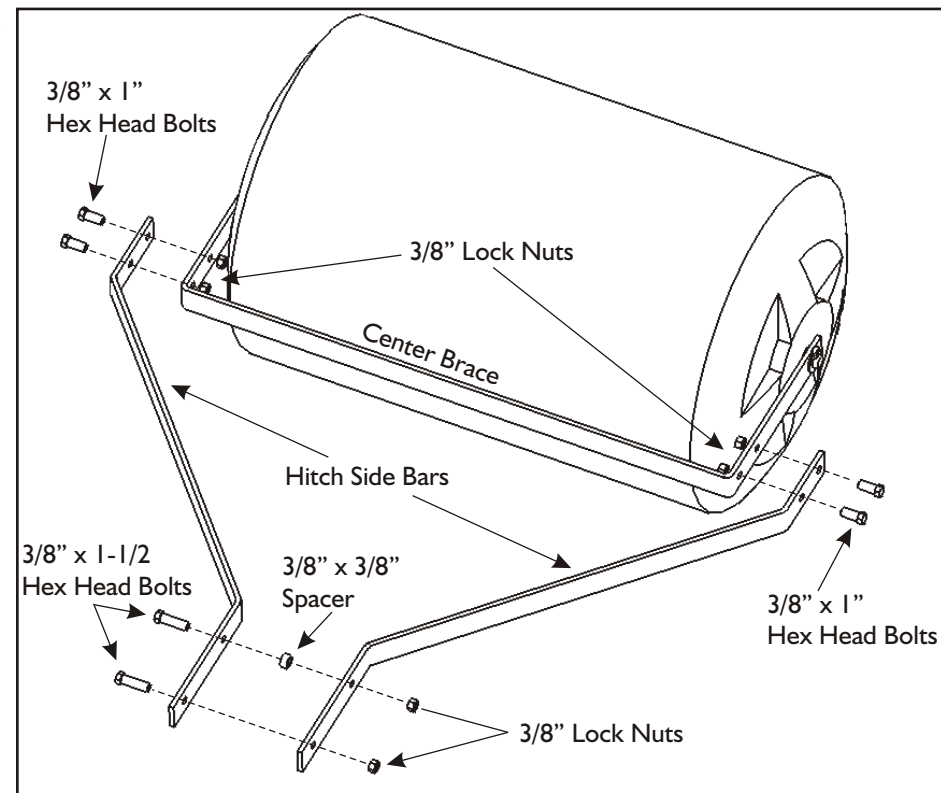

## STEP 3

Figure 4

Attach the two Clevis Plates (13) to the end of the Hitch Side Bars using 3/8" x 2-1/4" Hex Head Bolts (9) and 3/8" Lock Nuts (5). The bolts for the Clevis Plates "straddle" (one bolt on each side) of the first 3/8" x 1-1/2" Hex Head Bolt on the end of the Hitch Side Bar. This keeps the Clevis Plate assembly from slipping off the Hitch Side Bars when the unit is in use. Fig. 4

Now tighten the four 3/8" Hex Head Bolts (3/8" x 1-1/2" from STEP 2 and the 3/8" x 2-1/4" from the above procedure) and 3/8" Lock Nuts. Fig. 4

Insert the Clevis Pin (11) through the hole on the Clevis Plates and secure with the #14 Hitch Pin Clip (14) Fig. 4

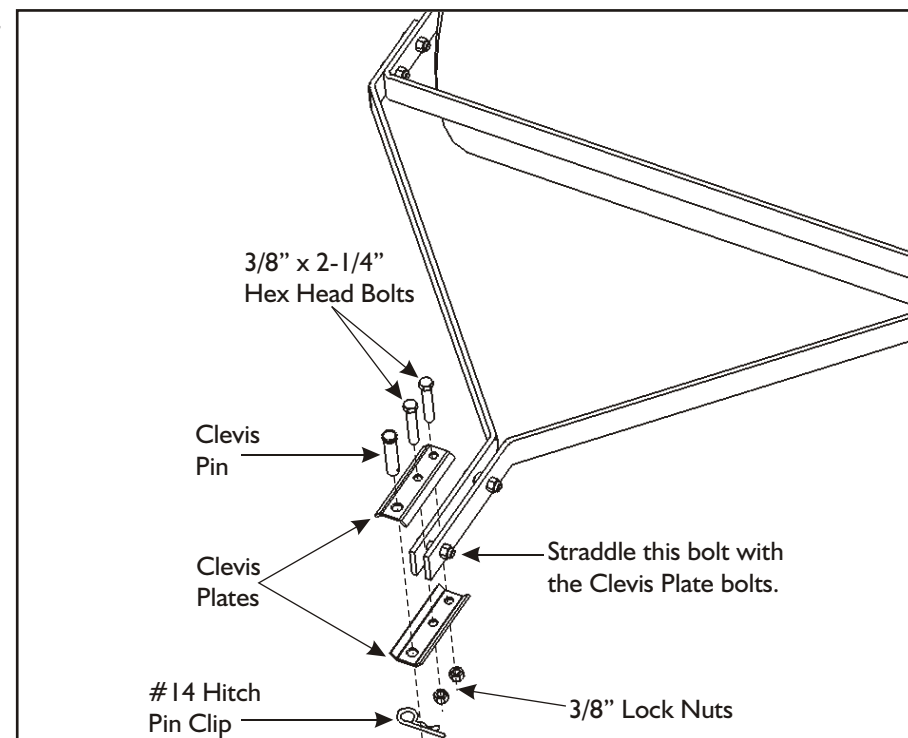

## STEP 4

Figure 5

Insert the Expansion Plug (2) into the hole on the end of the Roller Body. Secure by turning the wing nut on the Expansion Plug. Fig. 5

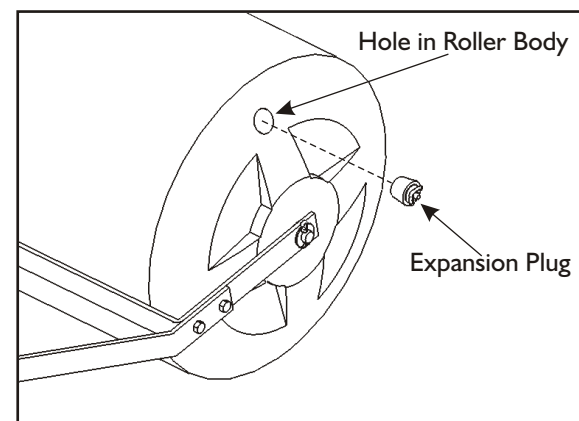

## HANDLE OPTION IS ON PLR1824 ONLY

### To use the handle option:

Remove the Clevis Pin and Hitch Pin Clip from the Clevis Plates. Loosen the two 3/8" Bolts on the Clevis Plates. Place the Handle Tube (17) in between the Clevis Plates. Insert the 1/2" x 2-1/2" Hex Head Bolt through the top Clevis Plate, the hole in the Handle Tube and the bottom Clevis Plate. Secure the 1/2" x 2-1/2" Bolt with a 1/2" Lock Nut. **NOTE: Do not over-tighten this bolt. It is possible to damage the Handle Tube by over-tightening the bolt. If the Handle Tube DOES get damaged; DO NOT USE. Personal injury can happen.**

Tighten the two Clevis Plate bolts. Place the 1" Handle Grips (15) over the ends of the Handle Tube.

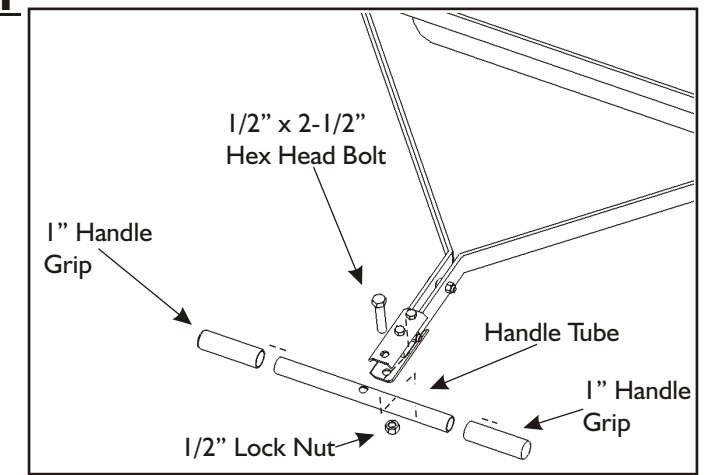

### SAFETY GUIDELINES FOR USE OF PRODUCT

- \*The most important information is knowing how to stop your riding mower or lawn tractor, read your equipment's owner's manual for horse power and towing weights
- \*With increased towing weight, your stopping distance increases also
- \*Do not tow (or push) the roller up or down steep ditches or hills. Be extremely cautious around steep grades
- \*Watch for holes, uneven terrain and other possible obstacles
- \*Inspect roller and all hardware periodically. Be sure all parts are secure before and during operation
- \*Never carry any passengers with you
- \*Do not operate lawn roller on slopes greater than 10 - 12 degrees

### USING YOUR LAWN ROLLER

- \*Remove the expansion plug by loosening the wing nut.
- \*Fill your roller with water or sand to recommended weight for your towing equipment (mower or lawn tractor). **DO NOT GO OVER YOUR TOWING EQUIPMENT'S WEIGHT LIMIT.** Failure to do so can result in damage to the towing equipment and/or personal injury.
- \*Replace the expansion plug and tighten the wing nut. Make sure the plug is tight enough to stop any leakage.
- \*Your lawn should be moist for best rolling conditions. Excessive water or muddy conditions are not recommended.
- \*Keep your mower or lawn tractor at a safe and steady speed. 3 - 4 MPH is a good speed for proper operation.
- \*Damage to your mower, lawn tractor and/or personal injury can occur if you start or stop the roller (filled) abruptly.
- \*When finished using the roller, drain and let the interior fully dry. Never leave water in the lawn roller during cold weather. Freezing can occur, damaging the plastic body causing leaks and/or structural failure.

### WEIGHT CAPACITIES PER MODEL

It is extremely important to know how much your mower or lawn equipment is designed to tow. Below are **approximate** weight capacities for individual models.

Model	Weight filled with water	Weight filled with sand
PLR1824	221 lbs.	353 lbs.
PLR1836	331 lbs.	530 lbs.

### MAINTENANCE

- \*Always check all the hardware before use. Make sure all hardware and components are tight and secure.
- \*Always keep moving joints lubricated. Lubricate where the Axle extends through the Hitch Side Bar when needed.
- \*Keeping the roller clean and dry will prolong the unit's life.
- \*Sand off any rust that might occur, and paint exposed metal with a quality enamel paint.

### LIMITED WARRANTY

This unit is warranted against defects in materials and workmanship to the original purchaser, under normal use and service, for a period of ninety (90) days from date of sale. During the Warranty Period, we will repair or replace at our option free of charge to the original purchaser, any part of the Unit that our examination shows to be defective in workmanship or materials. This Warranty **Does Not** apply to damage caused by transit, misuse, abuse, neglect, accident, normal wear, or alterations by unauthorized persons.