

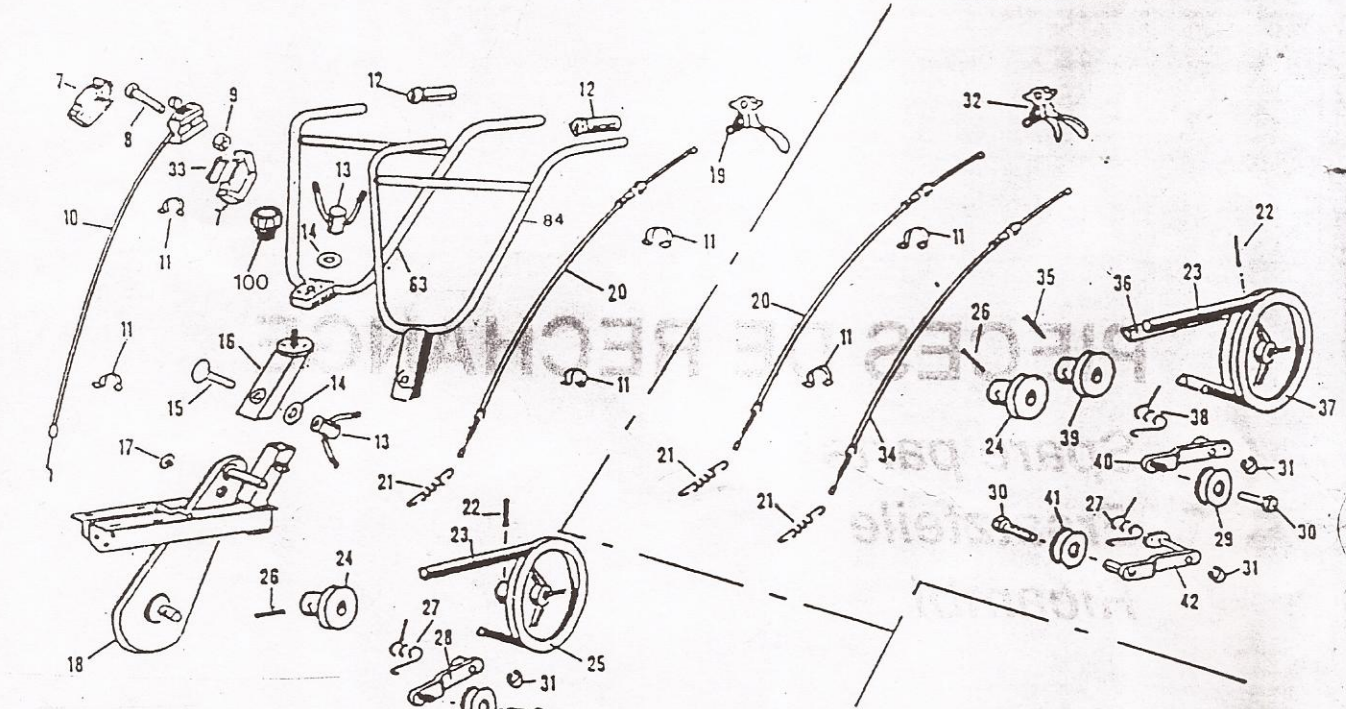

Rep Nr No N°	Réf. Ref. Besuch nr.	Designation - Part name Bezeichnung - Descrizione	3 cv	5 cv	S 200
1	30582	Extension D. - Extension R. - Verbreiterung R. - Estensione D.	X	X	
2	30838	Capot - Stone-guard - Werkzeug haube L. - Protezione	X	X	X
3	30581	Extension G. - Extension L. - Verbreiterung - Estensione S.	X	X	X
4	30603.	Fourche - Fork - Radgabel - Supporto	X	X	X
5	Z03.10.45	Vis - Screw - Scheibe - Vite	X	X	X
6	Z53.10	Ecrou - Nut - Mutter - Dado	X	X	X
7	30608	Cheville - Pin - Bolzen - Perno	X	X	X
8	16667	Goupille - Pin - Splint - Coppiglia	X	X	X
9	Z04.10.80	Boulon - Bolt - Scheibe - Vite	X	X	X
10	30601	Roue - Wheel - Rad - Ruota	X	X	X
11	30602	Coussinet - Spacer - Radlager	X	X	X
12	Z53.12	Ecrou - Nut - Mutter - Distanziale	X	X	X
13	Z03.12.100	Vis - Nut - Schraube - Dado	X	X	X
14	30578	Eperon - Leg - Stütze - Puntone	X	X	X
15	30611	Support - Support - Stützenträger - Supporto	X	X	X
16	30614	Eperon - Leg - Stütze - Puntone	X	X	X
17	30615	Clé - Pin - Schlüssel - Vite	X	X	X
18	30610	Ensemble éperon - Adjustable leg - Satz Stütze - Ass Puntone	X	X	X
19	31672	Ensemble roues - Carrying wheels - Satz Transportrad - Ass. Ruote	X	X	X
20	31675	Support - Support - Radträger - Supporto	X	X	X
21	31673	Etrier - Support - Bügel - Morsetto	X	X	X
22	31654	Eperon - Leg - Stütze - Puntone	X	X	X
23	Z08.Z12.U	Rondelle - Washer - Unterlegscheibe - Rondella	X	X	X
24	42008	Clips - Clip - Clip - Clips	X	X	X
25	31660	Ensemble roues - Carrying wheels - Satz transportrad - Ass. Ruote	X	X	X
26	31662	Fourche - Fork - Radgabel - Supporto	X	X	X
27	31661	Eperon - Leg - Stütze - Puntone	X	X	X
28	30583	Couronne 30 X 5 - Hoe wheel 30 X 5 - Kranz 30 X 5 - Fresa 30 X 5	X		
	30630	Couronne 40 X 4 - Hoe wheel 40 X 4 - Kranz 40 X 4 - Fresa 40 X 4	X	X	X
29	30622	Couronne D. 30 X 5 - R/H Hoe wheel 30 X 5 - Kranz R. 30 X 5 - Fresa DX 30 X 5	X		
	30636	Couronne D. 40 X 4 - R/H Hoe wheel 40 X 4 - Kranz R. 40 X 4 - Fresa DX 40 X 4	X	X	X
30	30621	Couronne G. 30 X 5 - L/H Hoe wheel 30 X 5 - Kranz L. 30 X 5 - Fresa SX 30 X 5	X		
	30637	Couronne G. 40 X 4 - L/H Hoe wheel 40 X 4 - Kranz L. 40 X 4 - Fresa SX 40 X 4	X	X	X
31	Z04.8.40	Vis - Screw - Schraube - Vite	X	X	X
32	Z53.8	Ecrou - Nut - Mutter - Dado	X	X	X
33	30649	Disque protège-plantes plastique - Disc - Schutzscheibe - Dischi Plastique	X	X	X
	30641	Disque protège-plantes métallique - Disc - Schutzscheibe - Dischi	X	X	X
34	30810	Couronne 30 X 5 - Hoe wheel 30 X 5 - Kranz 30 X 5 - Fresa 30 X 5	X		
	30820	Couronne 40 X 4 - Hoe wheel 40 X 4 - Kranz 40 X 4 - Fresa 40 X 4	X	X	X
35	30830	Outils D. 30 X 5 - R/H Hoe tool 30 X 5 - Werkzeug R. 30 X 5 - Fresa DX 30 X 5	X		
	30832	Outils D. 40 X 4 - R/H Hoe tool 40 X 4 - Werkzeug R. 40 X 4 - Fresa DX 40 X 4	X	X	X
36	30831	Outils G. 30 X 5 - L/H Hoe tool 30 X 5 - Werkzeug L. 30 X 5 - Fresa SX 30 X 5	X		
	30833	Outils G. 40 X 4 - L/H Hoe tool 40 X 4 - Werkzeug L. 40 X 4 - Fresa SX 40 X 4	X	X	X
37	30653	Moyeu - Hub - Nabe - Mozzo	X	X	X
38	30812	Couronne G. 30 X 5 - L/H Hoe wheel 30 X 5 - Kranz L. 30 X 5 - Fresa SX 30 X 5	X		
	30827	Couronne G. 40 X 4 - L/H Hoe wheel 40 X 4 - Kranz L. 40 X 4 - Fresa SX 40 X 4	X	X	X
39	30818	Moyeu G. - Hub L/H - Nabe - Mozzo	X	X	X
40	30811	Couronne D. 30 X 5 - R/H Hoe wheel 30 X 5 - Kranz R. 30 X 5 - Fresa DX 30 X 5	X		
	30826	Couronne D. 40 X 4 - R/H Hoe wheel 40 X 4 - Kranz R. 40 X 4 - Fresa DX 40 X 4	X	X	X
41	30817	Moyeu D. - Hub R/H - Nabe R. - Mozzo DX	X	X	X
42	30854	Couronne G. 30 X 5 - L/H Hoe wheel 30 X 5 - Kranz L. 30 X 5 - Fresa SX 30 X 5	X		
	30855	Couronne G. 40 X 4 - L/H Hoe wheel 40 X 4 - Kranz L. 40 X 4 - Fresa SX 40 X 4	X	X	X
43	30856	Couronne D. 30 X 5 - R/H Hoe wheel 30 X 5 - Kranz R. 30 X 5 - Fresa DX 30 X 5	X		
	30857	Couronne D. 40 X 4 - R/H Hoe wheel 40 X 4 - Kranz R. 40 X 4 - Fresa DX 40 X 4	X	X	X
44	30858	Moyeu G. - Hub L/H - Nabe L. - Mozzo SX	X	X	X
45	30859	Moyeu D. - Hub R/H - Nabe R. - Mozzo DX	X	X	X
46	31493	Goupille - Pin - Splint - Coppiglia	X	X	X
47	Z03.08.50	Vis - Screw - Schraube - Vite	X	X	X
48	Z03.6.10	Vis - Screw - Schraube - Vite		6	6
49	Z53.6	Ecrou - Nut - Mutter - Dado		6	6
50	31494	Cache-écrou - Plastic cap - Mutterabdeckung - Copri		6	6

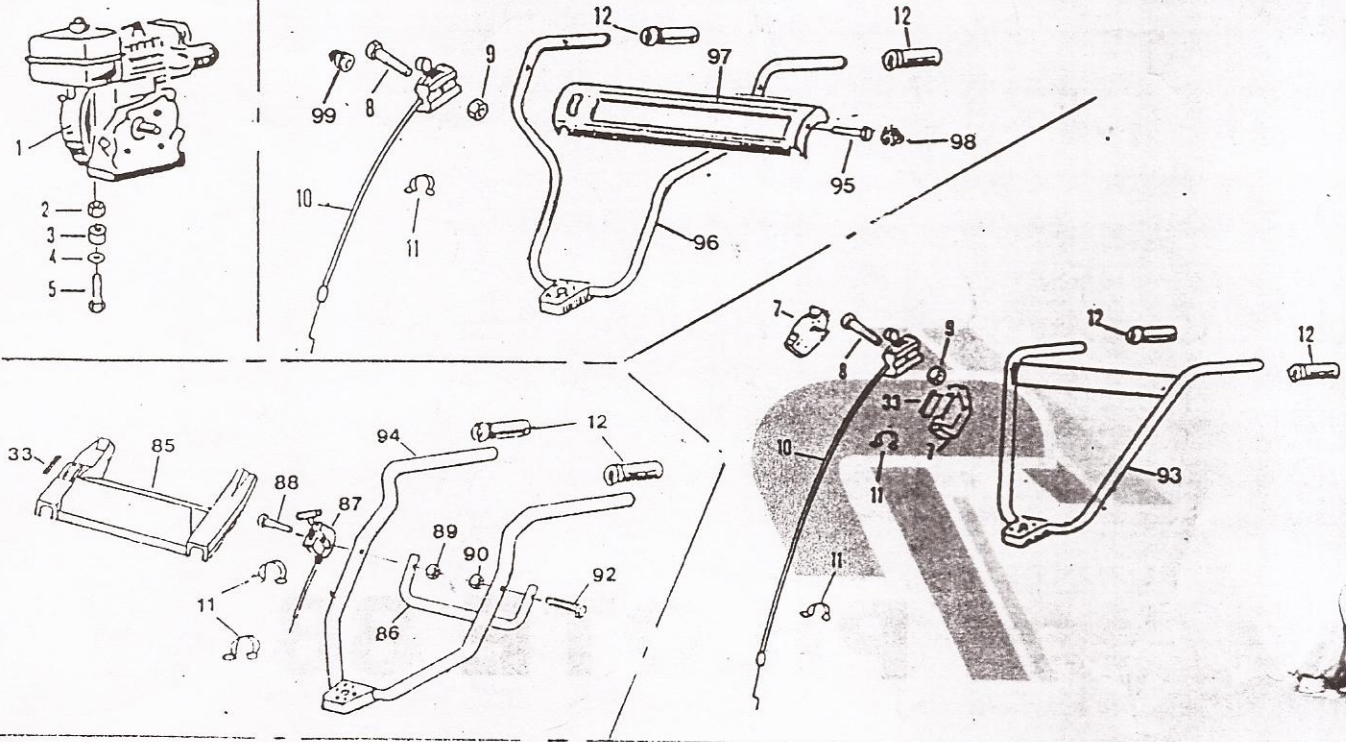

Carter boulonné
Revited carter
Genietet Rahmen
Carter vite

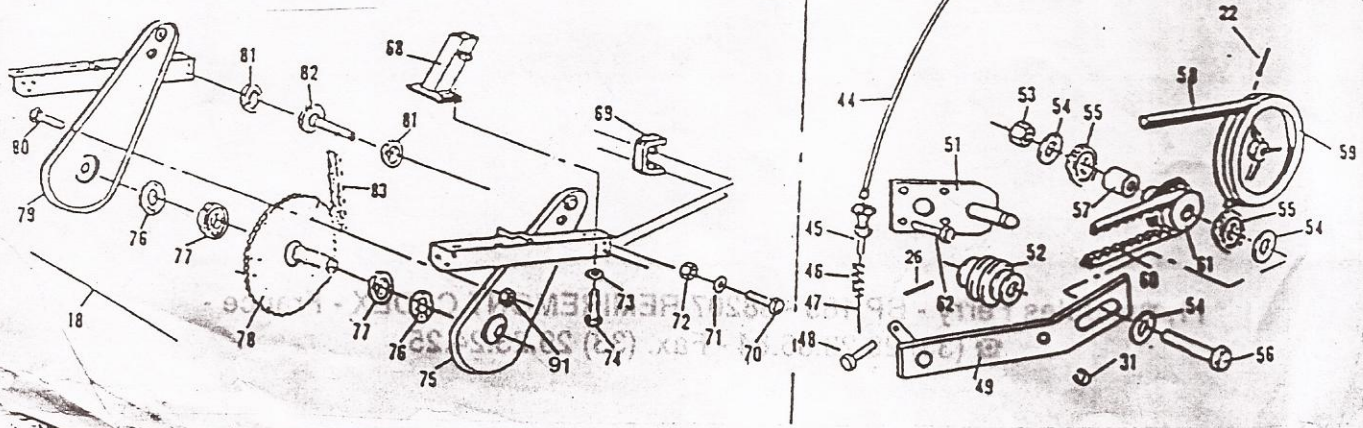



Rep Nr No	Réf. Ref Besuchnr	Désignation - Part name Bezeichnung - Descrizione - Designacion	3 cv	5 cv	5 cv MA	200 MA
1		Moteur - Engine - Motor - Motore				
2	Z53.8	Ecrou - Nut - Mutter - Dado	4	4	4	4
3	10124	Entretoise - Spacer - Abstandshülse - Distanziale	4	4	4	
	16245	Entretoise - Spacer - Abstandshülse - Distanziale				4
4	Z08L8N	Rondelle - Washer - Schelbe - Rondella	4	4	4	4
5	Z03.8.35	Vis - Bolt - Schraube - Vite	2			
	Z03.8.40	Vis - Bolt - Schraube - Vite	2			
	Z03.8.45	Vis - Bolt - Schraube - Vite		2	2	
	Z03.8.50	Vis - Bolt - Schraube - Vite		2	2	
	Z03.8.60	Vis - Bolt - Schraube - Vite				4
7	30494	Cache - Plastic cap - Durchsteckschr. Aweckung - Copri	X	X	X	X
8	Z03.5.45	Vis - Screw - Schraube - Vite	1	1	1	1
9	Z53.5	Ecrou - Nut - Mutter - Dado	1	1	1	1
10	30525	Commande - Throttle control - Gashebelgestange - Commando	1	1	1	1
11	42032	Collier - Clip - Klemmschelle - Ferma cavo	4	4	4	4
12	16706	Poignée - Handlebar grip - Sterzgriff - Manopola	2	2	2	2
13	30748	Ecrou - Nut - Mutter - Dado	2	2	2	2
14	30538	Rondelle - Washer - Scheibe - Rondella	2	2	2	2
15	Z42.12.45	Vis - Coach bolt - Schraube - Vite	1	1	1	1
16	30747	Potence - Strong stanction assy. - Tragsaule, montiert - Supporto	1	1	1	1
17	10055	Obturateur - Plastic plug - Verschluss - Otturatore	2	2	2	2
18	30677	Carter soudé - Welded casing - Getriebekasten, geschweißt - Carter	X	X		X
	30700	Carter soudé - Welded casing - Getriebekasten, geschweißt - Carter			X	
	30983	Carter soudé - Welded casing - Getriebekasten, geschweißt - Carter			X	
	31122	Carter boulonné - Bolted casing - Getriebekasten, verbolzt	X	X	X	X
	31132	Carter boulonné - Bolted casing - Getriebekasten, verbolzt			X	
	31146	Carter boulonné - Bolted casing - Getriebekasten, verbolzt			X	
19	30803	Poignée - Clutch lever - Kupplungshebel - Leva	1	1		
	30903	Poignée Honda - Clutch lever Honda - Kupplungshebel Honda - Leva Honda		X		
20	31351	Timonerie - Clutch control - Gestänge - Commando	1	1	1	1
21	30564	Ressort - Clutch spring - Kupplungsfeder - Molla	1	1	2	1
22	013.6.25	Goupille - Pin - Splint - Spina	1	1	1	
23	31207	Courroie - Belt - Riemen - Cinghia	1	1	1	
24	30544	Poulie - Pulley - Treibschelbe - Puleggia	1	1	1	
25	30619	Poulie - Pulley - Treibschelbe - Puleggia	1	1	1	
26	052.8.8	Vis - Screw - Schraube - Vite	1	1	1	1
27	30563	Ressort - Spring - Rückzugfelder - Molla	1	1	1	1
28	30557	Bras - Arm - Vorrichtung - Supporto	1	1		
	30709	Bras - Arm - Vorrichtung - Supporto				1
29	30554	Galet - Tension wheel - Riemenspanrolle - Ruotino tenditore	1	1	1	1
30	Z03.10.20	Vis - Bolt - Schraube - Vite	1	1	2	1
31	062.RS 9	Circlip - Circlip - Clips - Seeger	2	2	3	3
32	30804	Poignée double - Double clutch - Kupplungsgriff - Manopola			1	1
33	47085	Autocollant - Sticker - Aufkleber - Decalco	1	1	1	1
34	31352	Timonerie M. arrière - Clutch control - Kupplungsgestänge - Commando			1	1
35	024.6.10	Vis - pointed screw - Schraube - Vite			1	1
36	31202	Courroie - Belt - Riemen - Cinghia			1	1
37	31203	Poulie - Pulley - Treibrab - Puleggia			1	1
38	30477	Ressort Bras - Arm - Rückzugsfeder - Molla			1	1
39	30457	Poulie M. arrière - Pulley - Treibschelbe - Puleggia			1	1
40	30749	Bras M. arrière - Arm - Vorrichtung - Supporto ruotino			1	1
41	11030	Galet M. Avant - Tensioner wheel - Riemenspanrolle - Ruotino			1	1
42	30670	Bras M. Avant - Arm - Vorrichtung - Supporto			1	1
44	31353	Gaine M. Arrière - Reverse clutch cable sheatling - Kupplungskabel			1	1
45	10140	Trompette - Cable adjuster - Einstellrückzugsfeder				1
46	14250	Ressort câble - Spring - Kabelrückzugsfeder				1
47	31354	Câble - Control cable - Kabel				1
48	Z03.5.12	Vis - Bolt - Schraube				1
49	30794	Bras M. Arrière - Arm - Treibschelb				1
51	30728	Platine - Support - Tragplatte - Supporto				1
52	30793	Poulie - Pulley - Treibschelb				1
53	Z53.12	Ecrou - Nut - Mutter				1
54	009.12	Rondelle - Washer - Schreibe				3
55	030.6001.2	Roulement - Bearing - Kugellager, dicht				2
56	Z03.12.60	Vis - Bolt - Schraube				1
57	30796	Entretoise - Spacer - Distanzstück				1
58	19750	Courroie - Belt - Treibriemen				1
59	30690	Poulie - Pulley - Treibschelb				1
60	30798	Courroie - Belt - Treibriemen				1
61	30786	Galet - Wheel - Riemenspanrolle				1
62	023.8.16	Vis - Screw - Schraube				3
63	30489	Mancheron - Handelbar - Sterz - Manico	1	1	1	1
68	31126	Gaine - Fixed stanction - Hülse	1	1	1	1
69	31168	Chape - Mainframe yoke - Abdeckung Sporn	1	1	1	1
70	003.10.40	Vis - Screw - Schraube	2	2	2	2
71	012.10.AZ	Rondelle - Washer - Scheibe	2	2	2	2
72	011.10	Ecrou - Nut - Mutter	2	2	2	2
73	012.8.AZ	Rondelle - Washer - Scheibe	4	4	4	4
74	003.8.12	Vis - Screw - Schraube	4	4	4	4
75	-31123	Demi-carter - Transmission casing - Halbes Getriebegehäuse	1	1		1
	-31133	Demi-carter - Transmission casing - Halbes Getriebegehäuse			1	
76	16625	Joint - Rotary hoe shaft seal - Wellendichtung	2	2	2	2
77	030.6007.2	Roulement - Bearing - Kugellager, dicht	2	2	2	2
78	30518	Arbre - Rotary hoe shaft - Welle Fräsensträger	1	1	1	1
79	-31124	Demi-carter - Transmission casing - Halbes Getriebegehäuse	1	1	1	1
80	003.5.10	Boulon - Bolt - Durchsteckschraube	20	20	20	20
81	030.6003.2	Roulement - Bearing - Kugellager, dicht	2	2	2	2
82	30515	Arbre - Mainshaft - Antriebswelle	1	1	1	1
83	30521	Chaîne - Chain - Kette	1	1	1	1
84	30865	Mancheron - Handelbar - Sterz	1	1	1	1
85	30835	Tableau de bord - Control panel - Armaturenbriett - Panel de commando	1	1	1	1
86	30849	Barre de renfort - Bar - Strange - Tirante	1	1	1	1
87	72356	Commande - Throttle control - Gashebelgestange - Commando	1	1	1	1
	38093	Commande Honda - Throttle control Honda - Gashebelgestange Honda - Commando Honda			1	
88	Z03.5.55	Vis - Screw - Schraube - Vite	1	1	1	1
89	Z53.5	Ecrou - Nut - Mutter - Dado	1	1	1	1
90	Z53.6	Ecrou - Nut - Mutter - Dado	1	1	1	1
91	Z53.5	Ecrou - Nut - Mutter - Dado	1	1	1	1
92	Z03.6.40	Vis - Screw - Schraube - Vite	20	20	20	20
93	30484	Mancheron - Handelbar - Sterz - Manico	1	1	1	1
94	30836	Mancheron - Handelbar - Sterz - Manico	1	1	1	1
95	Z03.6.35	Vis - Screw - Schraube - Vite	1	1	1	1
96	31348	Mancheron - Handelbar - Sterz - Manico	1	1	1	1
97	31141	Tableau de bord - Control panel - Armaturenbriett - Panel de commando	1	1	1	1
98	31494	Cache-écrou - Plastic cap - Mutterabdeckung - Copri	1	1	1	1
99	31529	Cache-écrou - Plastic cap - Mutterabdeckung - Copri	1	1	1	1
100	31231	Bouton - Knob - Knopf - Pomolo	1	1	1	1
		DEMARRAGE ELECTRIQUE - ELECTRIC STARTER - ELEKTROSTART				
	30989	Faisceau électrique - Circuit - Kabel				
	30988	Batterie - Battery - Batterie				
	30979	Chargeur - Chargeur - Ladegerat				
	30978	Contacteur - Switch - Schalter				