

ILLUSTRATED PARTS LIST

MODEL NO. 96041013700

CUSTOMER CATALOG NO. LZ11577RB

PRODUCT NO. 960 41 01-37



**TRACTOR -- MODEL NUMBER LZ11577RB (96041013700), PRODUCT NO. 960 41 01-37
DECALS**

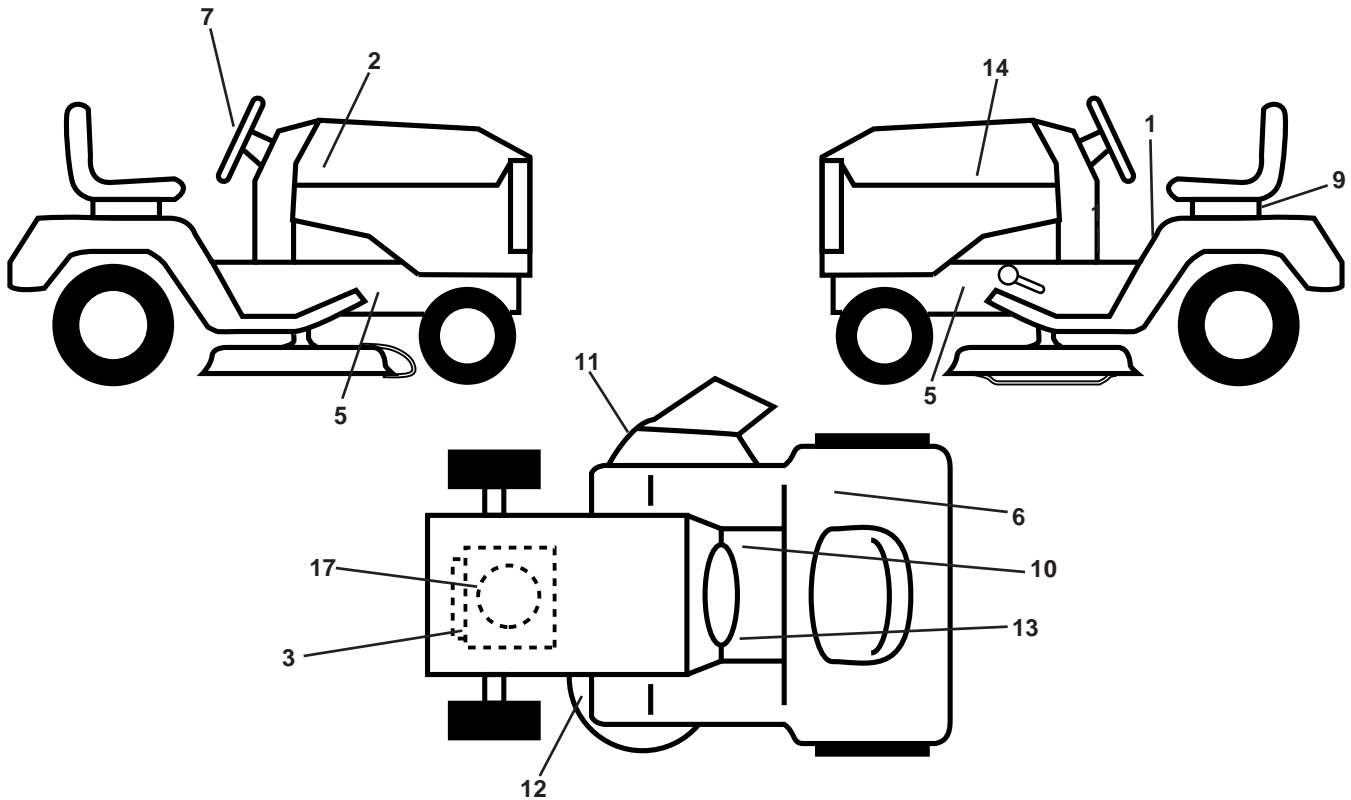

KEY NO.	PART NO.	DESCRIPTION
1	532 40 03-89	Decal, Operators
2	532 42 65-80	Decal, Hood Logo RH
3	532 19 68-41	Decal, Warning Eng. Symbols
5	532 15 97-36	Decal, Chassis Hot Muffler
6	532 18 04-32	Decal, Fender 100 DB/CE
7	532 42 65-82	Decal, Wheel Steering
9	532 14 50-05	Decal, Battery Dnge/Poi
10	532 14 08-37	Decal, Saddle Brake Parking
11	532 42 51-13	Decal, Warning DFlect/Ctfrngr
12	532 42 15-43	Decal, Mower V-Belt Schematic
13	532 15 97-37	Decal, Brake/Clutch Symbol

KEY NO.	PART NO.	DESCRIPTION
14	532 42 65-81	Decal, Hood Logo LH
17	532 40 88-12	Decal, BS Engine
--	532 42 59-76	Pad, Footrest, LH
--	532 42 59-28	Pad, Footrest, RH
--	532 42 64-54	Manual Oper. Euro
--	532 42 64-55	Manual Oper. Scand
--	532 42 64-56	Manual Oper. E-Bloc
--	532 42 64-57	Manual Oper. Baltic

WHEELS AND TIRES

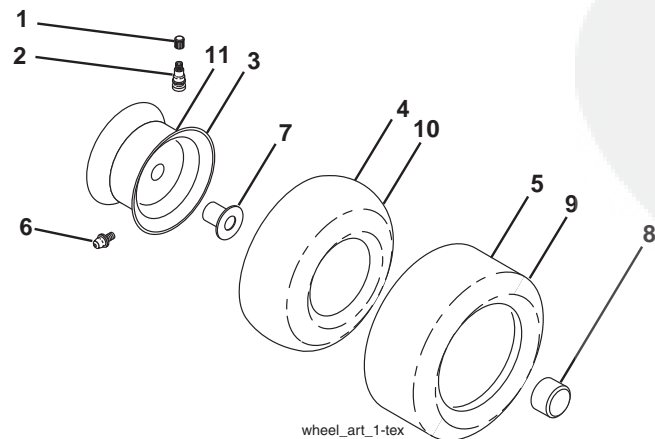

KEY NO.	PART NO.	DESCRIPTION
1	532 05 91-92	Cap Valve Tire
2	532 06 51-39	Stem Valve
3	532 42 67-59	Rim Asm 6 x 3.25 Front
4	532 42 16-52	Tube Front 13x5-6 (Service Item Only)
5	532 12 34-10	Tire F T 13 x 5.0 - 6
6	532 12 49-57	Fitting Grease (Front Wheel Only)
7	532 12 49-59	Bearing Flange (Front Wheel Only)
8	532 17 50-39	Cap Axle Blk 1 50 x 1 00
9	532 10 62-30	Tire R 16 x 6.5
10	532 00 71-54	Tube Rear (Service Item Only)
11	532 42 67-60	Rim Asm 8 x 5.375 Rear
--	532 14 43-34	Sealant, Tire (10 oz. Tube)

NOTE: All component dimensions given in U.S. inches
1 inch = 25.4 mm

TRACTOR -- MODEL NUMBER LZ11577RB (96041013700), PRODUCT NO. 960 41 01-37 SCHEMATIC

SCH17

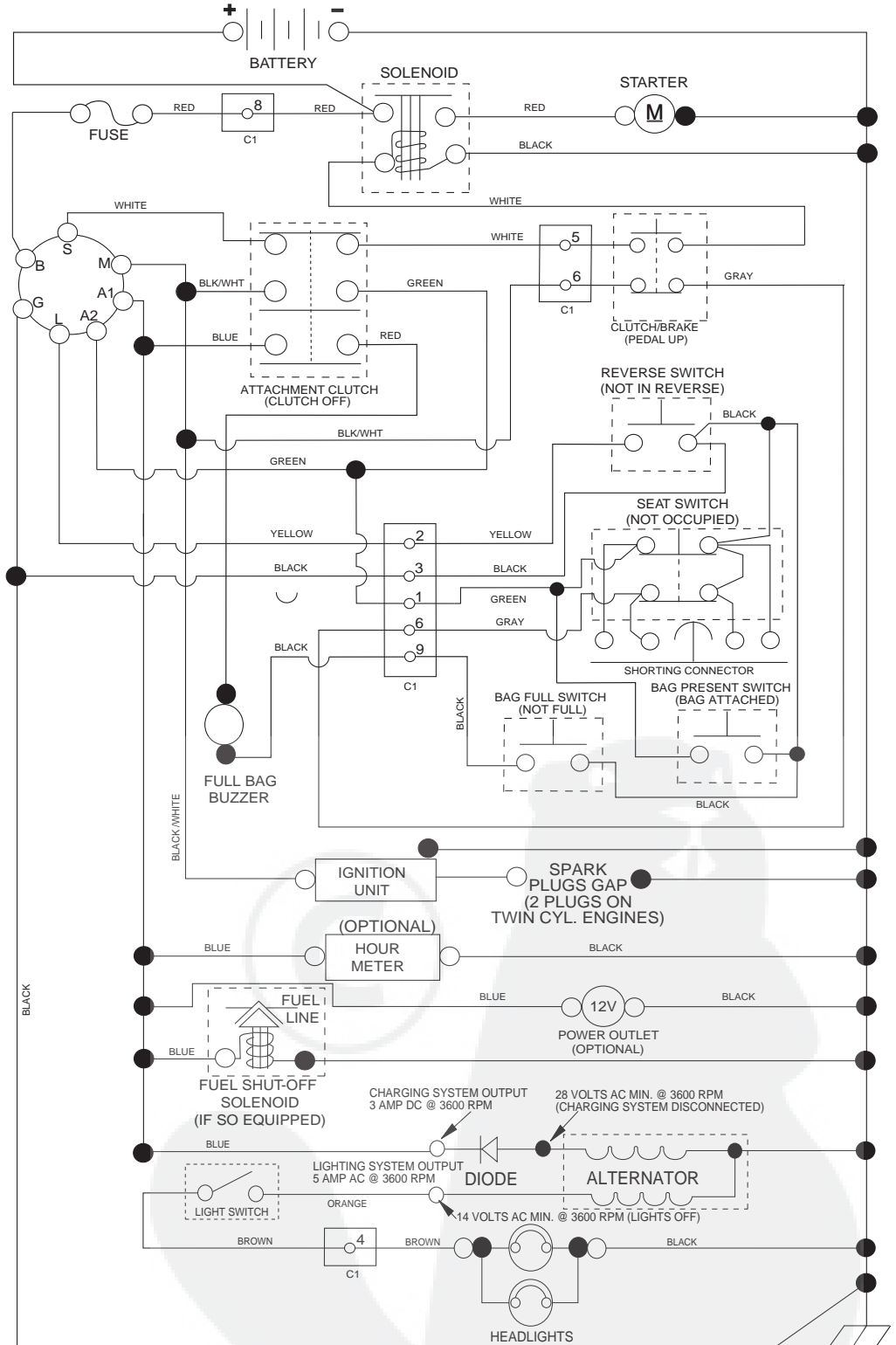

NOTE
YOUR TRACTOR IS EQUIPPED WITH A SPECIAL ALTERNATOR SYSTEM. THE LIGHTS ARE NOT CONNECTED TO THE BATTERY, BUT HAVE THEIR OWN ELECTRICAL SOURCE. BECAUSE OF THIS, THE BRIGHTNESS OF THE LIGHTS WILL CHANGE WITH ENGINE SPEED. AT IDLE THE LIGHTS WILL DIM. AS THE ENGINE SPEED IS INCREASED, THE LIGHTS WILL BECOME THEIR BRIGHTEST.

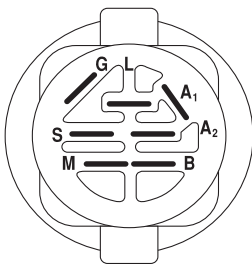

IGNITION SWITCH

POSITION	CIRCUIT	"MAKE"
OFF	M+G+A1	
RUN/OVERRIDE	B+A1	
RUN	B+A1	L+A2
START	B + S + A1	

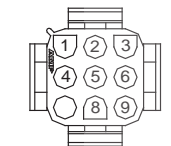

CHASSIS HARNESS CONNECTOR (C1) (MATING SIDE)

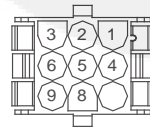

DASH HARNESS CONNECTOR (C1) (MATING SIDE)

WIRING INSULATED CLIPS
NOTE: IF WIRING INSULATED CLIPS WERE REMOVED FOR SERVICING OF UNIT, THEY SHOULD BE RE-INSTALLED TO PROPERLY SECURE YOUR WIRING.

NON-REMOVABLE CONNECTIONS

REMOVABLE CONNECTIONS

TRACTOR--MODEL NUMBER LZ11577RB (96041013700), PRODUCT NO.96041 01-37
ELECTRICAL

S01S

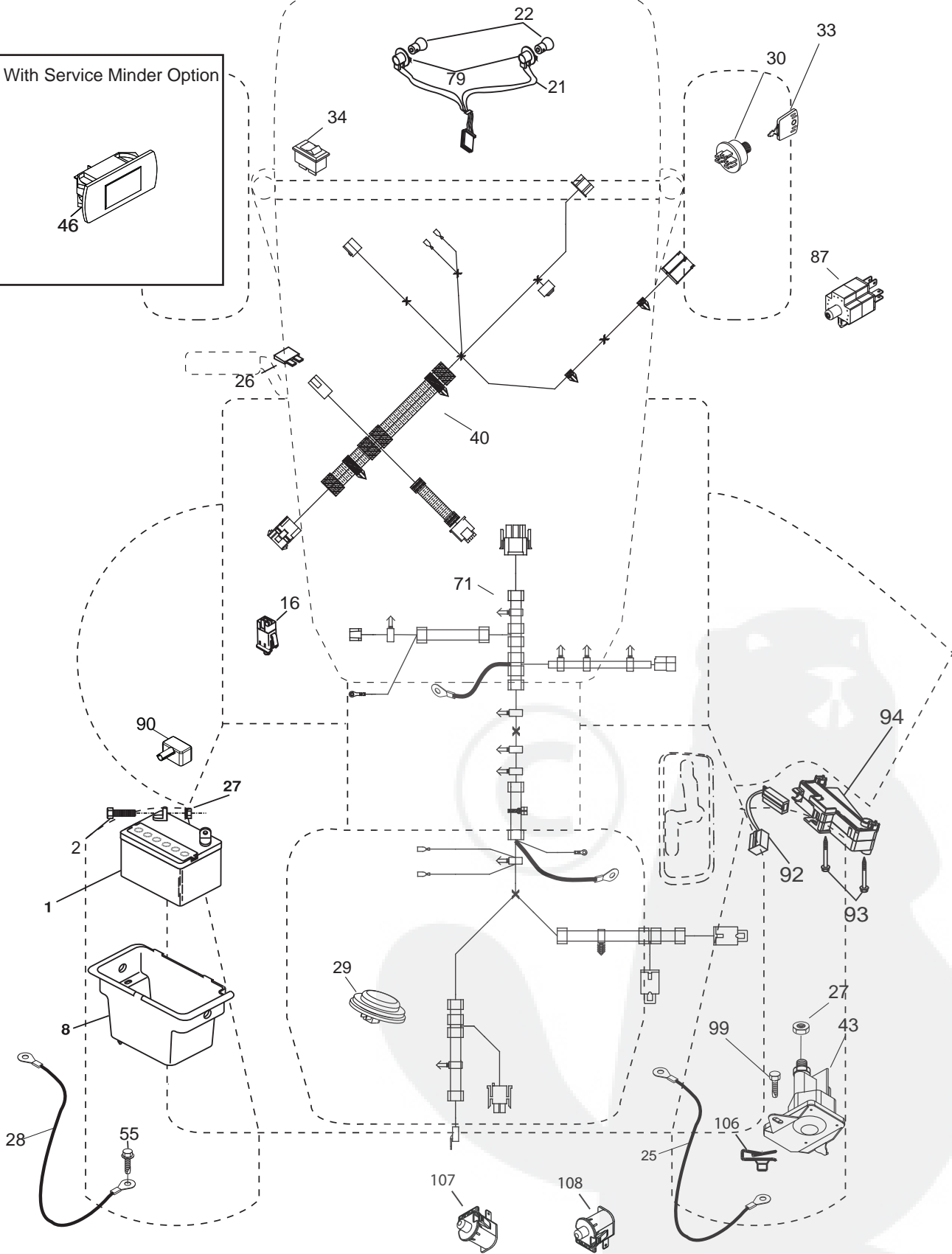
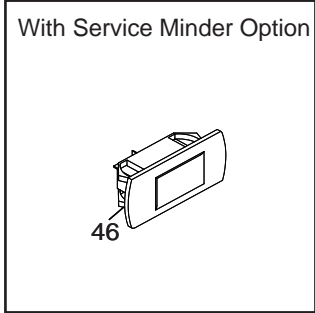

**TRACTOR -- MODEL NUMBER LZ11577RB (96041013700), PRODUCT NO. 960 41 01-37
ELECTRICAL**

KEY NO.	PART NO.	DESCRIPTION
1	532 14 49-24	Battery
2	874 76 04-12	Bolt Hex Head 1/4-20 x 3/4
8	532 41 97-91	Box Battery
16	532 17 61-38	Switch Interlock Push-In
21	532 18 37-59	Harness Socket Light w/4152J
22	532 00 41-52	Bulb Light
25	532 41 66-94	Cable Starter
26	532 17 51-58	Fuse
27	873 51 04-00	Nut Keps Hex 1/4-20 unc
28	532 42 16-86	Cable, Ground
29	532 40 15-45	Switch, Seat
30	532 19 33-50	Switch, Ign
33	532 41 19-35	Key/Chain
34	532 11 07-12	Switch Light/Reset
40	532 42 10-02	Harness Ign. Dash
43	532 19 25-07	Solenoid
55	817 06 05-12	Screw Thdrol 5/16-18 x 3/4 TYTT
71	532 42 10-01	Harness Ign. Chassis
79	532 17 52-42	Socket Asm. Bulb
87	532 42 10-60	Switch Railmount NO-NC-NC
90	532 40 07-25	Cover Terminal
92	532 19 66-15	Harness Pigtail Console ROS
93	532 19 25-40	Screw Plastite 10-14 x 2.0
94	532 19 18-34	Module Reverse
99	817 67 04-12	Screw 1/4-20 x 3/4
106	532 17 48-14	Palnut 1/4 Lugs
107	532 42 10-61	Switch Snapmount No #2
108	532 42 10-62	Switch Snapmount NC

NOTE: All component dimensions given in U.S. inches
1 inch = 25.4 mm

**TRACTOR -- MODEL NUMBER LZ11577RB (96041013700), PRODUCT NO. 96041 01-37
CHASSIS**

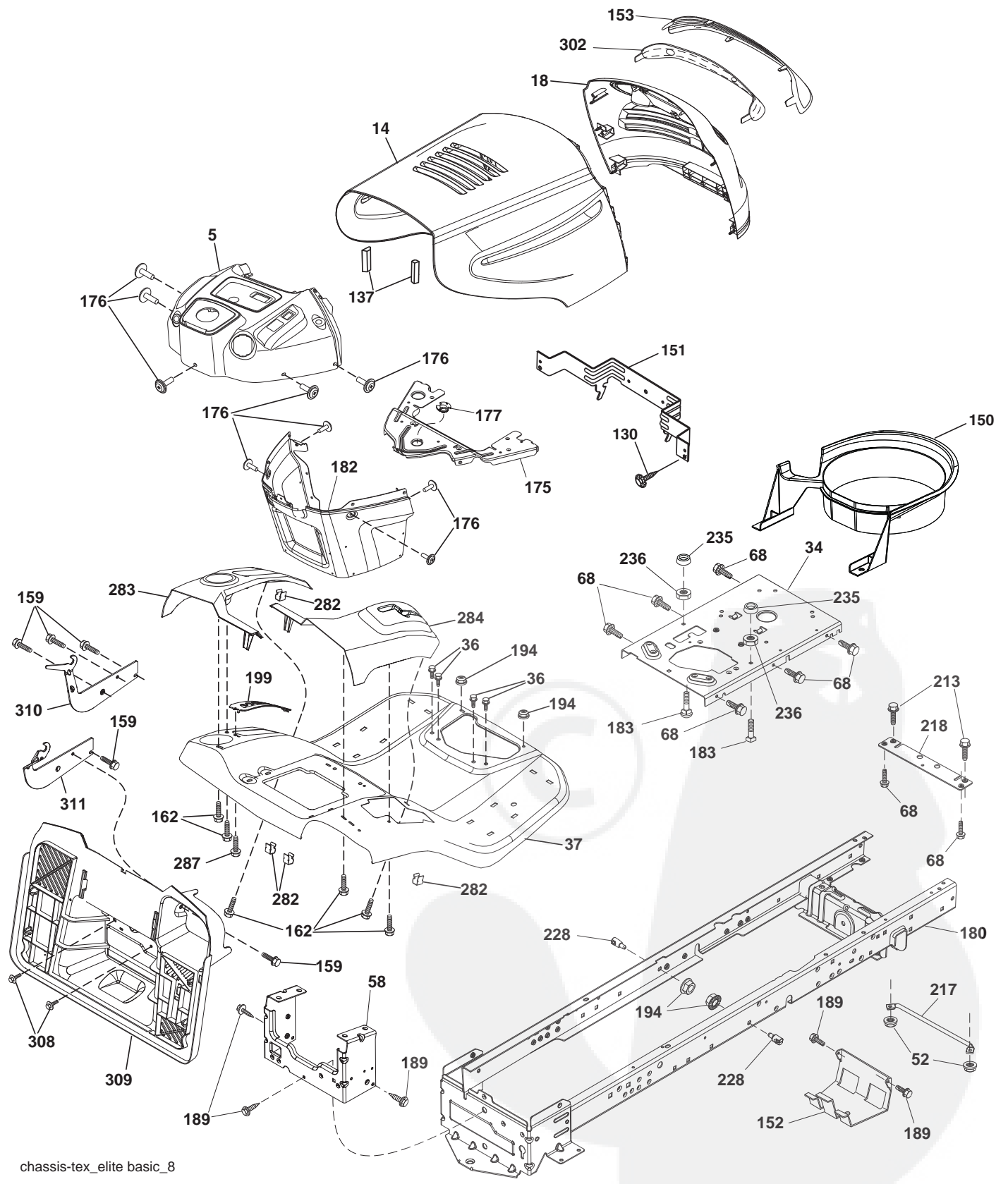

chassis-tex_elite basic_8

**TRACTOR -- MODEL NUMBER LZ11577RB (96041013700), PRODUCT NO. 960 41 01-37
CHASSIS**

KEY NO.	PART NO.	DESCRIPTION
5	532 41 17-64	Dash
14	532 18 67-07	Hood
18	532 42 67-92	Grille
34	532 19 61-25	Plate Engine
36	817 06 05-12	Screw 5/16-18 x 3/4
37	532 42 59-98	Fender
52	873 68 05-00	Nut Crown Lock 5/16
58	532 41 22-80	Drawbar Upper
68	817 49 05-08	Screw Thdrol. 5/16-18 x 1/2
130	532 41 63-58	Screw #10 x 0.750 BOS Thread
137	532 18 49-21	Bumper Dash
150	532 18 44-61	Duct Intake Air
151	532 40 78-07	Bracket Pivot
152	532 19 95-35	Shield Browning
153	532 18 98-37	Lens Grille
159	817 00 06-12	Screw Kexwsh Thdr 3/8-16 x 3/4
162	532 14 24-32	Screw Hex Wsh. Hi-Lo 1/4 x 1/2 unc
175	532 19 32-43	Crossmember
176	532 40 07-76	Screw 10-24 x 5/8
177	532 19 52-28	Bushing Steering
180	532 41 46-85	Chassis
182	532 19 30-57	Dash Lower
183	874 78 05-20	Bolt 5/16-18 unc x 1-1/4
189	817 00 05-12	Screw 5/16-18 x 3/4
194	873 90 05-00	Nut Lock Hex Flange 5/16-18
199	532 41 87-39	Plate Deck Lift
213	874 76 05-12	Bolt 5/16-18 x 3/4
217	532 40 91-67	Rod Pivot Hood
218	532 19 63-95	X-Piece Hood Stop
228	532 19 51-61	Stud Fastener
235	532 40 61-29	Spacer Fender
236	873 93 05-00	Nut Lock 5/16-18 unc
282	532 41 41-10	Clip Retainer
283	532 42 59-46	Console Deck Lift
284	532 42 59-45	Console Shift
287	817 60 04-06	Screw Hex Washhead 1/4-20 x 3/8
302	532 18 38-23	Insert Lens Refl
308	532 17 18-77	Bolt 5/16-18 unc x 3/4
309	532 41 71-91	Backplate Bagger SRD
310	532 41 71-95	Bracket Hangar Bag LH
311	532 41 71-96	Bracket Hangar Bag RH

NOTE: All component dimensions given in U.S. inches
1 inch = 25.4 mm

TRACTOR -- MODEL NUMBER LZ11577RB (96041013700), PRODUCT NO. 96041 01-37
DRIVE

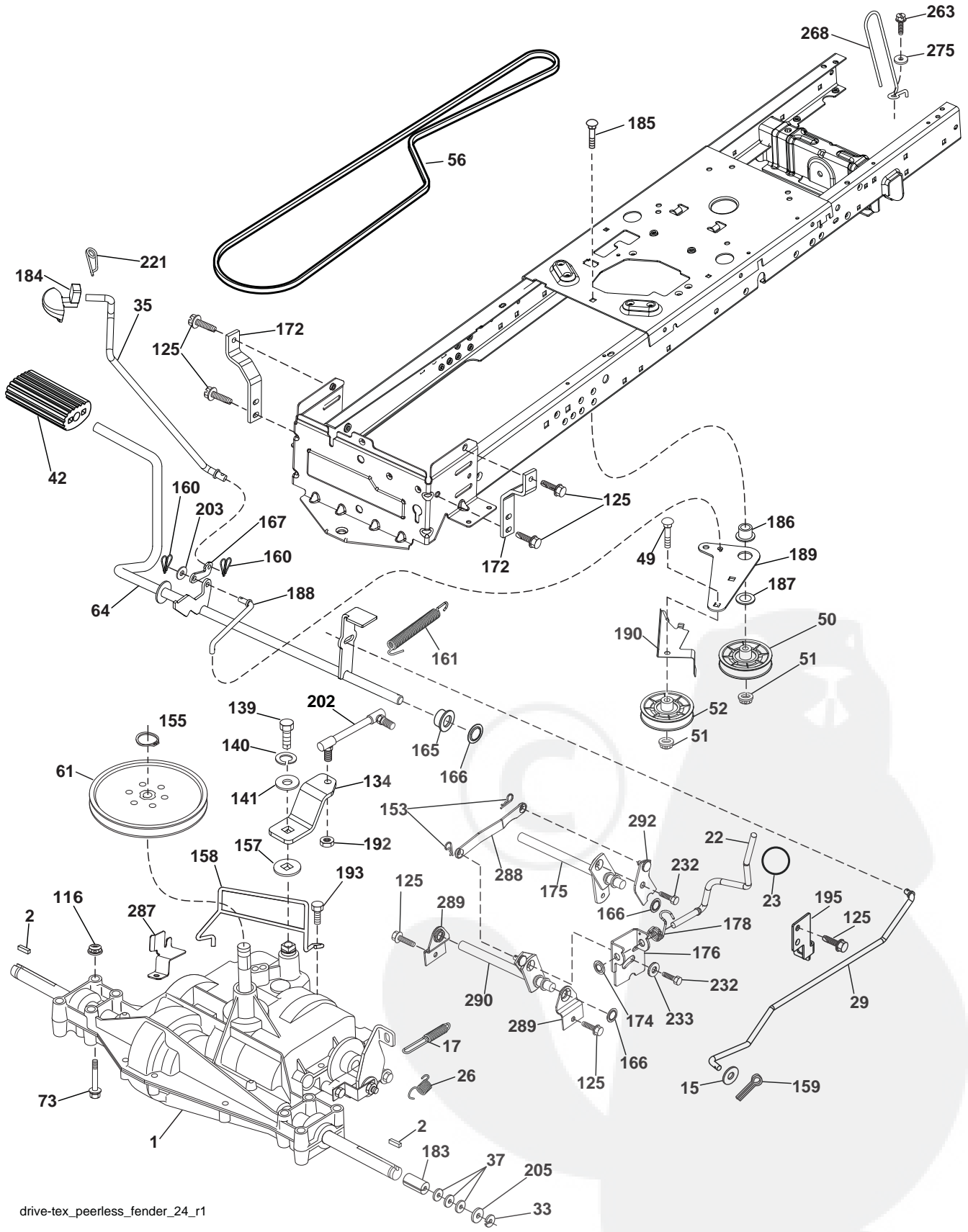

drive-tex_peerless_fender_24_r1

TRACTOR -- MODEL NUMBER LZ11577RB (96041013700), PRODUCT NO. 960 41 01-37 DRIVE

KEY NO.	PART NO.	DESCRIPTION	KEY NO.	PART NO.	DESCRIPTION
1	-----	Transaxle, Peerless 206-565	167	532 40 52-57	Latch Brake Parking
2	532 12 35-83	Key Square	172	532 19 76-57	Strap Torque LH
15	819 13 13-16	Washer 13/32 x 13/16 x 16 Ga.	174	532 19 72-89	Nut Push
17	532 19 72-97	Spring, Brake	175	532 19 78-58	Shaft Asm Shift
22	532 41 66-14	Rod Shift	176	532 19 62-14	Arm Clevis Rod Shift
23	532 17 16-74	Knob	178	532 19 63-14	Spring Shift
26	532 19 74-55	Spring Brake RTN	183	532 13 70-57	Spacer, Axle
29	532 19 72-67	Rod, Brake	184	532 41 12-89	Handle Parking Brake
33	812 00 00-01	Ring E	185	872 11 06-22	Bolt
35	532 19 77-22	Rod, Brake, Park	186	532 19 43-21	Spacer Retainer
37	532 12 17-49	Washer 25/32 x 1-1/4 x 16 Ga.	187	819 13 32-10	Washer
42	532 12 48-72	Cover, Foot Pedal	188	532 19 43-23	Link Clutch Ground Drive
49	872 11 06-14	Bolt	189	532 19 43-17	Bellcrank Ground Drive
50	532 19 43-27	Pulley Idler Flat	190	532 19 43-18	Keeper Bellcrank Ground Drive
51	873 90 06-00	Lock Nut 3/8-16	192	532 15 03-60	Nut Lock Center 1/4-28
52	532 19 43-26	Idler V-Groove	193	817 06 05-12	Screw 5/16-18 x 3/4
56	532 13 82-55	Belt, Drive	195	532 19 73-32	Bracket Brake Rod
61	532 16 59-99	Pulley Transaxle	202	532 19 78-59	Link Shift
64	532 19 62-00	Shaft Asm. Pedal Brake Control	203	819 11 11-16	Washer 11/32 x 11/16 x 16 Ga.
73	874 49 05-44	Bolt 5/16-18 Gr. 5	205	532 12 17-48	Washer 25/32 x 1-5/8 x 16 Ga.
116	873 90 05-00	Nut Lock Hex Flange 5/16-18	221	532 40 31-87	Retainer Spring Clip Handle
125	817 00 05-12	Screw 5/16-18 x 3/4	232	874 78 07-16	Bolt 7/16-14 x 1 Gr. 5
134	532 19 78-57	Arm Shift	233	532 40 52-96	Washer Serrated
139	874 55 04-12	Bolt 1/4-20 unf Gr. 8 w/Patch	263	817 00 06-12	Screw Hexwsh Thdr 3/8-16 x 3/4
140	810 04 04-00	Washer Lock Hvy Helical 1/4	268	532 18 24-02	Guard Muffler
141	819 09 12-10	Washer 9/32 x 3/4 x 10 Ga.	275	819 13 16-14	Washer 13/32 x 1 x 14Ga.
153	532 12 47-88	Retainer Spring 1"	287	532 42 16-48	Keeper Pulley Transaxle
155	812 00 00-28	Ring Retainer	288	532 41 66-17	Link Shift Slave
157	532 10 57-01	Washer Plate Shf	289	532 41 75-20	Bracket Support Shift Outer
158	532 19 43-52	Keeper T/A	290	532 42 00-14	Shaft Asm. Shift Rear
159	876 02 04-12	Pin Cotter 1/8 x 3/4	292	532 41 93-07	Plate Asm. Shift
160	532 16 94-84	Retainer Clip			
161	532 10 57-09	Spring, Return, Clutch			
165	532 19 62-12	Busing Shaft Brake Hand Control			
166	532 19 72-90	Nut Push .625			

NOTE: All component dimensions given in U.S. inches
1 inch = 25.4 mm

**TRACTOR -- MODEL NUMBER LZ11577RB (96041013700), PRODUCT NO. 96041 01-37
ENGINE**

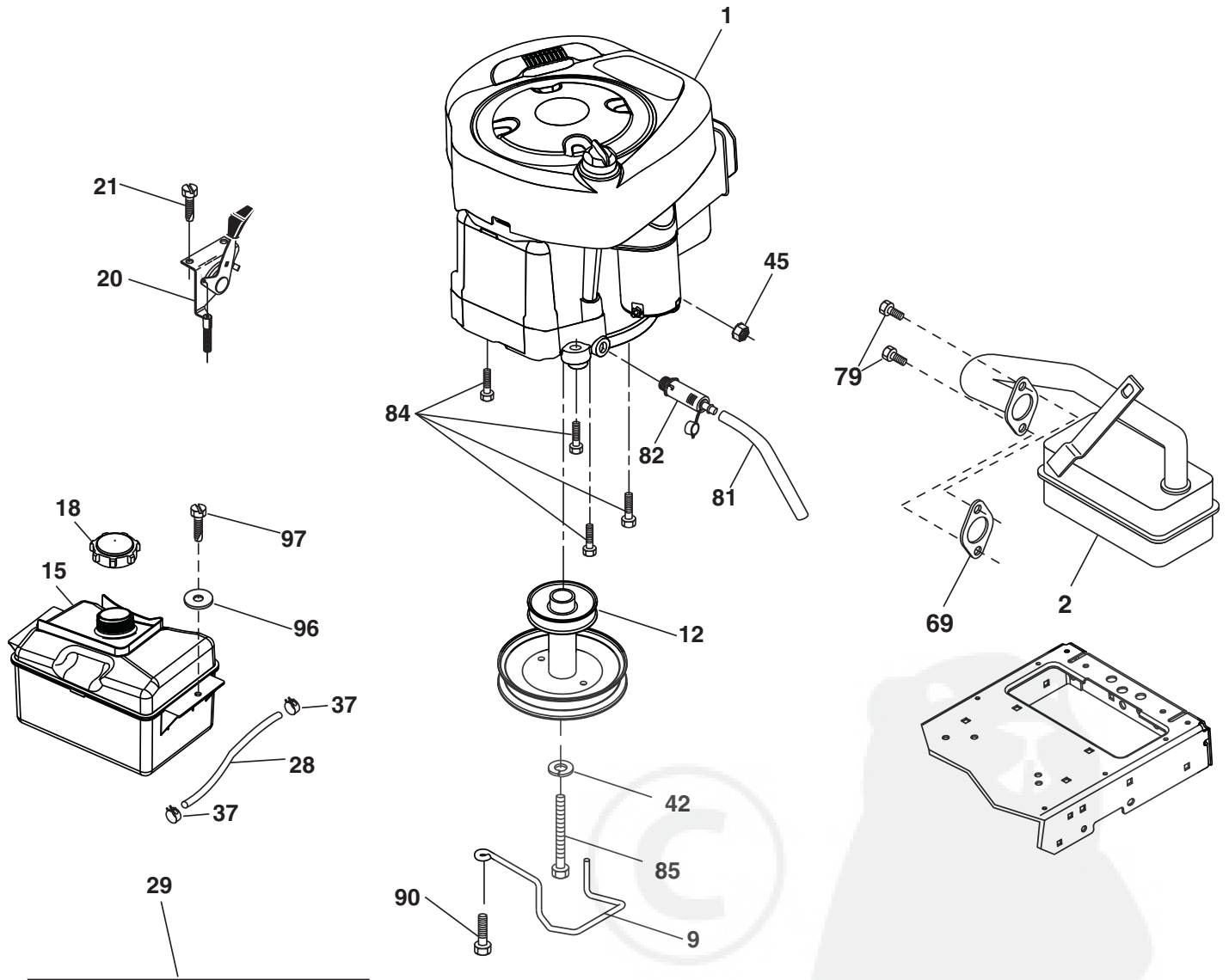

OPTIONAL EQUIPMENT
Spark Arrester

engine-bs-1cyl-tex_11

TRACTOR -- MODEL NUMBER LZ11577RB (96041013700), PRODUCT NO. 960 41 01-37 ENGINE

KEY NO.	PART NO.	DESCRIPTION
1	-----	Engine BS Model No. 217807
2	532 17 97-58	Muffler
9	532 19 43-19	Keeper Belt Engine
12	532 14 01-86	Pulley Engine
15	532 40 75-45	Tank Fuel 1.5
18	532 19 77-25	Cap Asm
20	532 18 38-97	Control Throttle
21	532 41 63-58	Screw #10 x 0.750 BOS Thread
28	532 13 70-40	Fuel Line
29	532 13 71-80	Spark Arrester Kit
37	532 12 34-87	Clamp Hose
42	810 04 07-00	Washer Lock Hvy HLCL SPR 7/16
45	873 51 04-00	Nut Keps Hex 1/4-20 unc
69	532 16 52-91	Gasket
79	532 19 23-34	Screw Socket HD 5/16 - 18 x 75
81	532 14 84-56	Tube Drain Oil Easy
82	532 18 16-54	Plug Drain Oil
84	817 06 06-20	Screw 3/8-16 x 1-1/4
85	871 17 07-64	Bolt Hex 7/16-20 x 4 Gr. 5
90	817 00 06-16	Screw 3/8-16 x 1
96	819 09 14-16	Washer 9/32 x 7/8 x 16 Ga.
97	817 67 04-12	Screw 1/4-20 x 3/4

NOTE: All component dimensions given in U.S. inches
1 inch = 25.4 mm

Engine Power Rating Information

The gross power rating for individual gas engine models is labeled in accordance with SAE (Society of Automotive Engineers) code J11940 (Small Engine Power & Torque Rating Procedure), and rating performance has been obtained and corrected in accordance with SAE J1995 (Revision 2002-5). Actual gross engine power will be lower and is affected by, among other things, ambient operating conditions and engine-to-engine variability. Given both the wide array of products on which engines are placed and the variety of environmental issues applicable to operating the equipment, the gas engine will not develop the rated gross power when used in a given piece of power equipment (actual "on-site" or net horsepower). This difference is due to a variety of factors including, but not limited to, accessories (air cleaner, exhaust, charging, cooling, carburetor, fuel pump, etc.), application limitations, ambient operating conditions (temperature, humidity, altitude), and engine-to-engine variability. Due to manufacturing and capacity limitations, Briggs & Stratton may substitute an engine of higher rated power for this Series engine.

**TRACTOR -- MODEL NUMBER LZ11577RB (96041013700), PRODUCT NO. 960 41 01-37
STEERING ASSEMBLY**

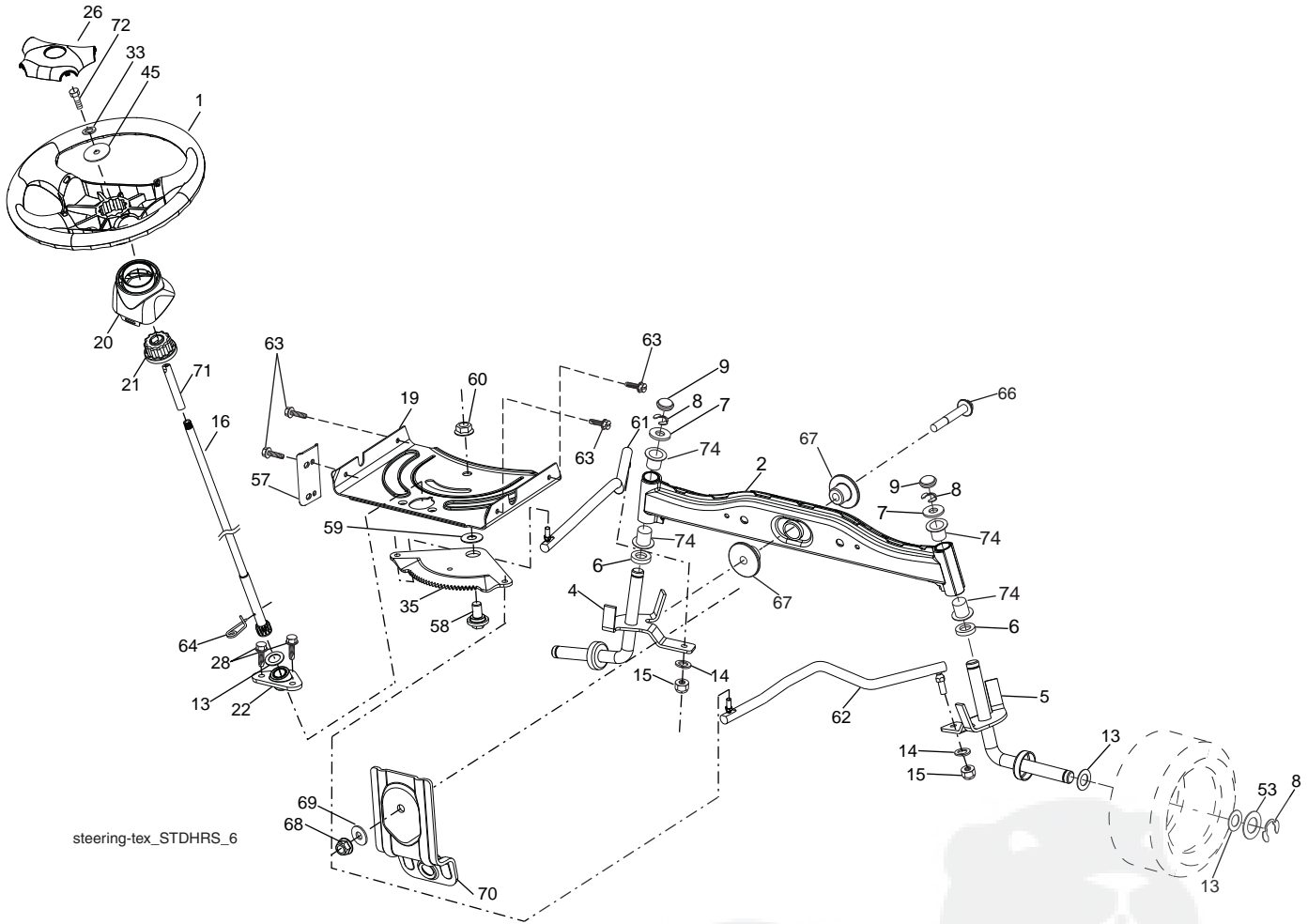

steering-tex_STDHRS_6

KEY NO.	PART NO.	DESCRIPTION
1	532 42 45-43	Wheel, Steering
2	532 41 81-68	Axle Asm., Front
4	532 41 68-45	Spindle Asm., LH
5	532 41 68-46	Spindle Asm., RH
6	532 12 49-31	Bearing, Race Thrust Hardened
7	532 12 17-48	Washer 25/32 x 1-5/8 x 16 Ga.
8	812 00 00-29	Ring, Klip #T5304-75
9	532 12 12-32	Cap, Spindle
13	532 12 17-49	Washer, 25/32 x 1-1/4 x 16 Ga.
14	810 04 06-00	Washer, Lock Hvy Hlcl Spr 3/8
15	873 54 06-00	Nut, Crown Lock 3/8-24 unf
16	532 19 60-74	Shaft Steering
19	532 19 47-29	Plate Steering
20	532 41 12-91	Boot, Steering
21	532 18 67-37	Adapter, Wheel Steering
22	532 19 48-45	Washer, Strg. Blk
26	532 42 46-91	Insert, Wheel Steering
28	817 00 06-12	Screw 3/8-16 x 3/4
33	810 04 05-00	Washer Lock 5/16
35	532 19 47-32	Gear, Sector Plate
45	819 11 38-12	Washer 11/32 x 3/8 x 12 Ga.
53	532 18 89-67	Washer Hardened .793 x 1.637 x .060

KEY NO.	PART NO.	DESCRIPTION
57	532 40 74-65	Bracket Upstop
58	532 19 47-47	Bolt Shoulder Sector Pivot CFM
59	532 19 47-48	Washer Thrust Sector Steering
60	873 97 10-00	Nut Flange Lock 5/8-11
61	532 19 47-40	Draglink, LH
62	532 19 47-41	Draglink, RH
63	817 00 05-12	Screw 5/16-18 x 3/4
64	532 19 98-49	Retainer Clip Spring Steering
66	871 02 07-48	Bolt Hex Fghd 7/16-14 x 3 Serr
67	532 19 47-37	Bushing PM Front Axle
68	873 90 07-00	Nut Lock Flange 7/16-14 Gr. 5
69	532 19 91-62	Washer 1.5 x .505 x .118
70	532 41 70-65	Bracket Deck Susp. Front
71	532 19 60-75	Shaft Extension Steering
72	874 78 05-72	Bolt 5/16-18 x 4.5 Gr.
74	532 12 49-37	Bearing

NOTE: All component dimensions given in U.S. inches
1 inch = 25.4 mm

**TRACTOR -- MODEL NUMBER LZ11577RB (96041013700), PRODUCT NO. 960 41 01-37
SEAT ASSEMBLY**

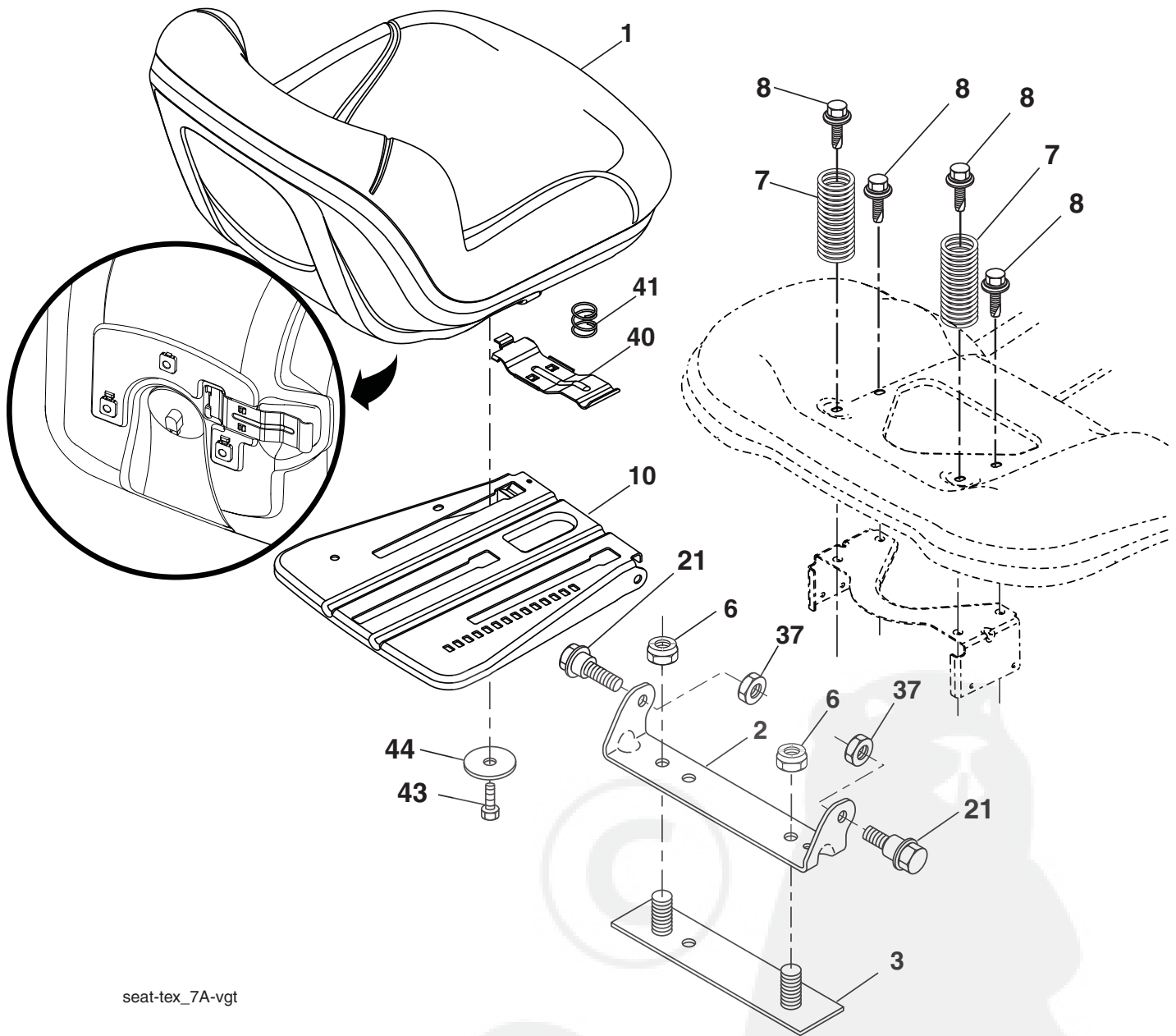

seat-tex_7A-vgt

KEY NO.	PART NO.	DESCRIPTION
1	532 19 75-11	Seat
2	532 18 01-66	Bracket Pivot Fender
3	532 14 06-75	Strap, Asm Fender
6	873 80 06-00	Nut, Lock w/Ins. 3/8-16 unc
7	532 12 41-81	Spring, Seat Cprsn
8	532 17 18-77	Bolt 5/16-18 unc x 3/4 w/Sems
10	532 19 69-77	Pan, Seat
21	532 17 18-52	Bolt, Shoulder 5/16-18

KEY NO.	PART NO.	DESCRIPTION
37	873 80 05-00	Nut, Lock 5/16-18 unc
40	532 19 76-61	Handle Slide Seat
41	532 19 82-00	Spring Latch Seat
43	874 76 06-12	Bolt 3/8-16 x 3/4
44	819 13 38-12	Washer 13/32 x 2-3/8 x 12 Ga.

NOTE: All component dimensions given in U.S. inches
1 inch = 25.4 mm

**TRACTOR -- MODEL NUMBER LZ11577RB (96041013700), PRODUCT NO. 96041 01-37
MOWER DECK**

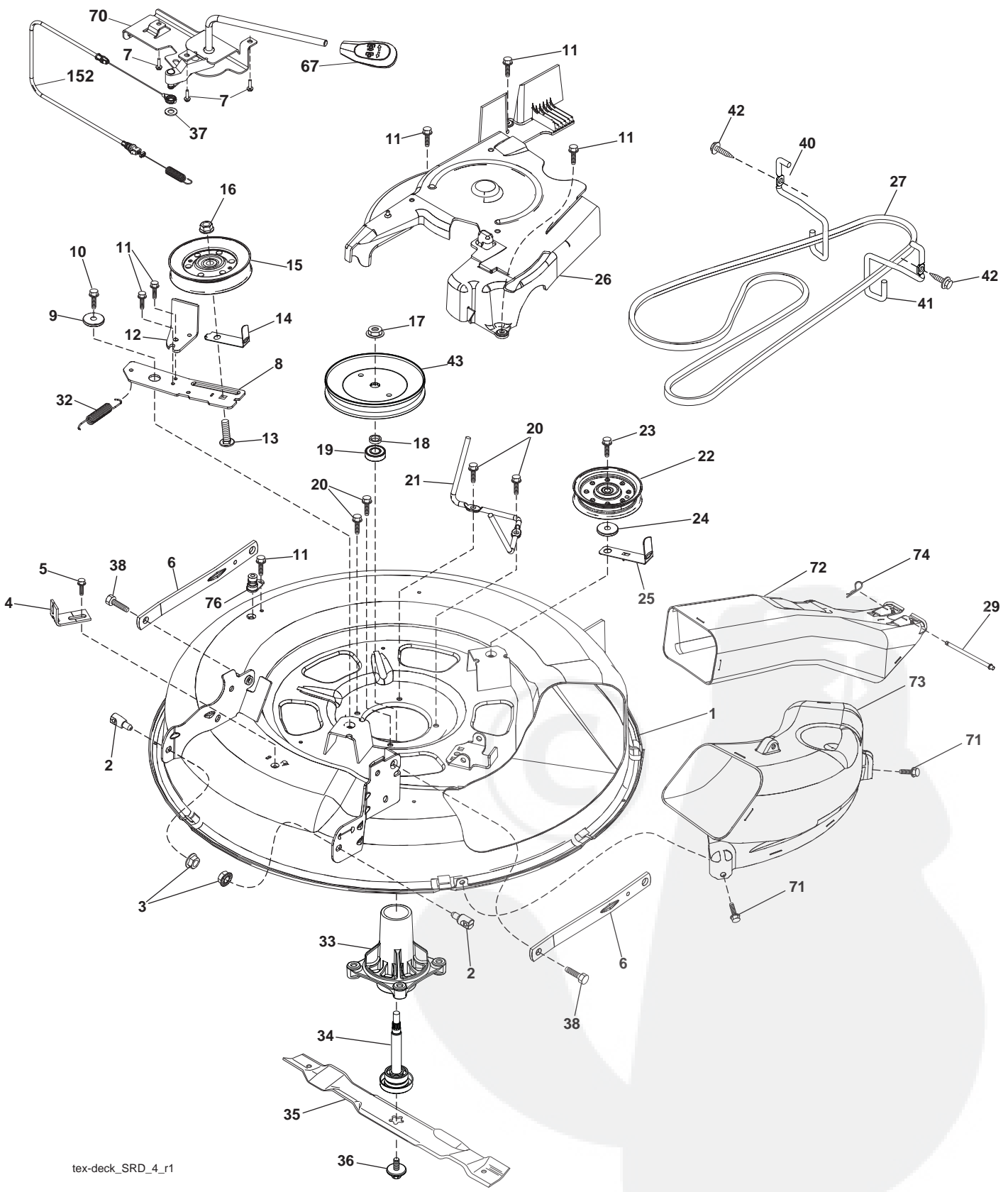

tex-deck_SRD_4_r1

**TRACTOR -- MODEL NUMBER LZ11577RB (96041013700), PRODUCT NO. 96041 01-37
MOWER DECK**

KEY NO.	PART NO.	DESCRIPTION
1	532 41 92-72	Deck Weldment 30"Srd
2	532 19 51-61	Stud Fastner W/D'anti-Rotatio
3	873 90 05-00	Nut Lock Hex Flange 5/16 - 18
4	532 41 76-45	Bracket Clutch Cable
5	817 00 05-10	Bolt 5/16-18
6	532 41 88-63	Arm Susp Mower Rear Srd
7	532 41 63-58	Screw #10 x 0.750 BOS Thread
8	532 42 02-52	Arm Idler 30"Srd
9	532 19 90-92	Spacer Retainer
10	817 00 06-16	Screw 3/8 - 16 X 1 Smgml Tap/R Blk
11	532 13 77-29	Screw Thd Roll 1/4 - 20 X 5/8
12	532 19 94-70	Arm Brake Mower 38" RH Tex
13	872 11 06-12	Bolt Carr Sh 3/8 - 16 X 1 - 1/2 Gr5
14	532 15 60-85	Keeper Belt Idler
15	532 14 67-63	Pulley Idler V-Groove Dim 4.25
16	873 90 06-00	Nut Lock FIG 3/8 - 16 unc
17	532 40 02-34	Nut Flange Lock Top
18	532 18 76-90	Washer Spacer Mandrel
19	532 11 04-85	Bearing Ball Mandrel
20	532 17 39-84	Screw Thd Roll Dod Pt Hex
21	532 41 69-10	Keeper Belt Mandrel 30"
22	532 19 31-98	Pulley Idler Flat Unplated
23	817 49 06-28	Screw Thdrol 3/8 - 16 X 1-3/4
24	819 13 20-12	Washer 13/32 X 1 - 1/4 X 12 Ga
25	532 42 02-53	Keeper Belt 30"Srd
26	532 42 02-55	Cover Mandrel Mwr 30"Black
27	532 12 65-20	V-Belt 88.45 GND DR/30" MWR
29	532 42 08-95	Hinge Pin
32	532 40 18-72	Spring Return Deck 38/46"
33	532 18 72-81	Housing Mandrel 4pt Service
34	532 19 28-72	Shaft Asm Mndrl N/Greaseable38
35	532 41 92-74	Blade Mower Bagging Srd
36	532 19 30-03	Bolt/Washer Asm 7/16 - 20 unf
37	819 13 13-16	Washer 13/32 x 13/16 x 16 Ga.
38	532 19 65-39	Bolt Shoulder
40	532 41 92-70	Keeper Belt Engine LH
41	532 41 92-65	Keeper Belt Engine RH
42	817 00 06-12	ScrewHexwsh THDR 3/8-16x3/4BL
43	532 41 68-77	Pulley Mandrel 6 5 Pd 30"
67	532 40 30-12	Handle Clutch Cable
70	532 19 83-32	Clutch Asm. Manual
71	817 67 06-08	Screw 3/8-16 x 1/2
72	532 41 72-36	Chute Upper SRD 30R
73	532 42 52-74	Chute Lower SRD 30R
74	532 12 46-70	Retainer Spring
76	532 41 55-98	Port Washout
152	532 40 87-14	Manual Clutch Cable
--	532 41 64-05	Coupling Quick Connect
--	532 19 28-70	Mandrel Assembly (Includes Hous- ing, Shaft Assembly, And Bearing Only - Pulley/Nut/Washer And Blade Bolt/Washers Not Included)
--	532 42 16-06	Replacement Mower Complete

NOTE: All component dimensions given in U.S. inches
1 inch = 25.4 mm

**TRACTOR -- MODEL NUMBER LZ11577RB (96041013700), PRODUCT NO. 96041 01-37
MOWER LIFT**

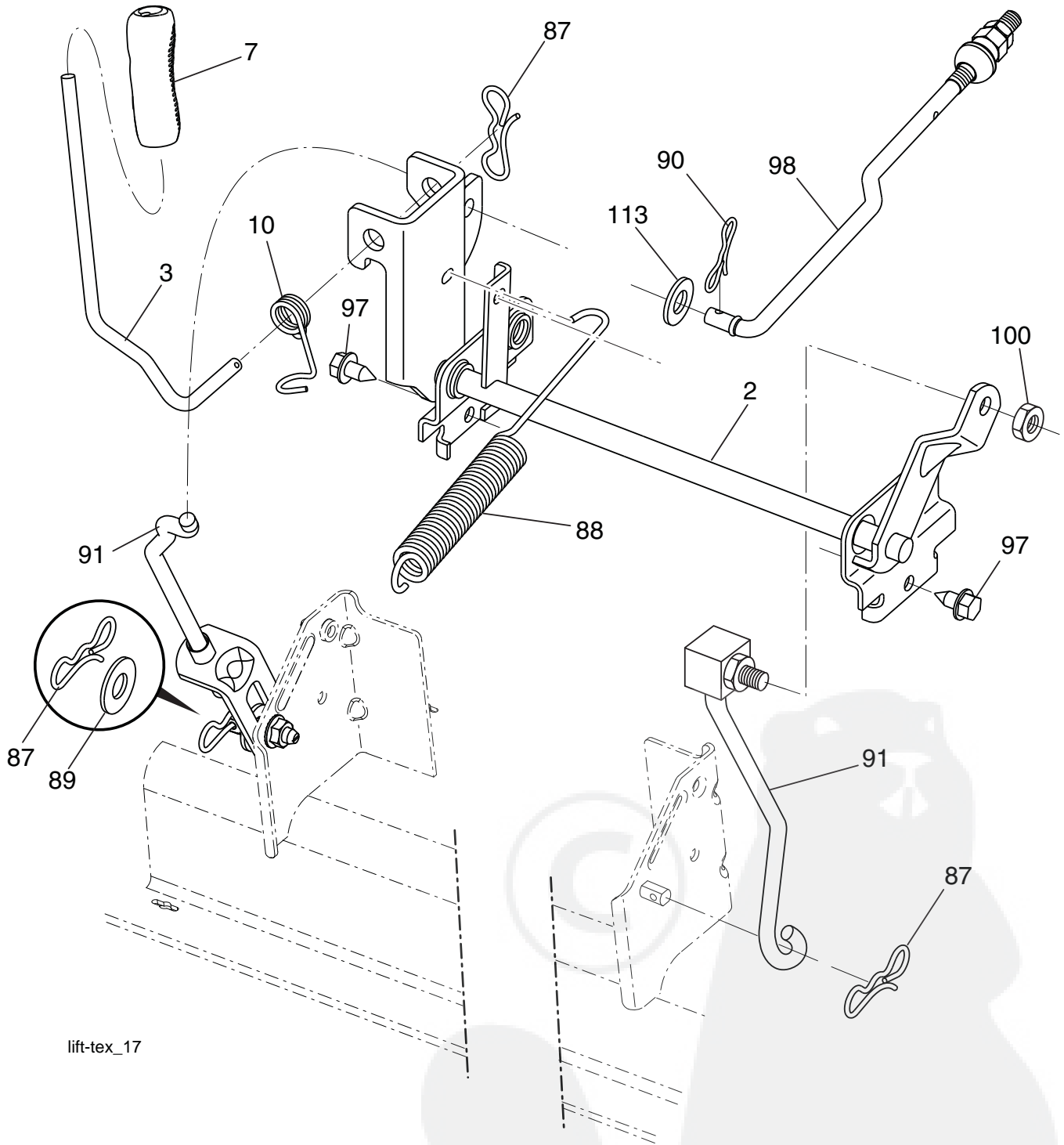

lift-tex_17

KEY NO.	PART NO.	DESCRIPTION
2	532 19 52-23	Shaft Asm., Lift
3	532 19 52-31	Lever Asm., Lift RH
7	532 41 15-55	Grip, Lever
10	532 19 63-14	Spring Torsion
87	532 19 42-09	Pin Cotter 7/16 Bow Tie Lock
88	532 41 07-10	Spring Lift Assist
89	819 19 19-12	Washer Clear
90	532 19 42-08	Pin Cotter 5/16 Bow Tie Lock

KEY NO.	PART NO.	DESCRIPTION
91	532 19 51-81	Link Lift Susp Mower Rear
97	817 00 06-12	Screw 3/8-16 x 3/4
98	532 19 52-64	Link Lift Susp. Front Mower
100	873 93 06-00	Nut Centerlock 3/8-16
113	819 17 19-12	Washer 17/32 x 1-3/16 x 12 Ga.

NOTE: All component dimensions given in U.S. inches
1 inch = 25.4 mm

**TRACTOR -- MODEL NUMBER LZ11577RB (96041013700), PRODUCT NO. 960 41 01-37
BAGGER**

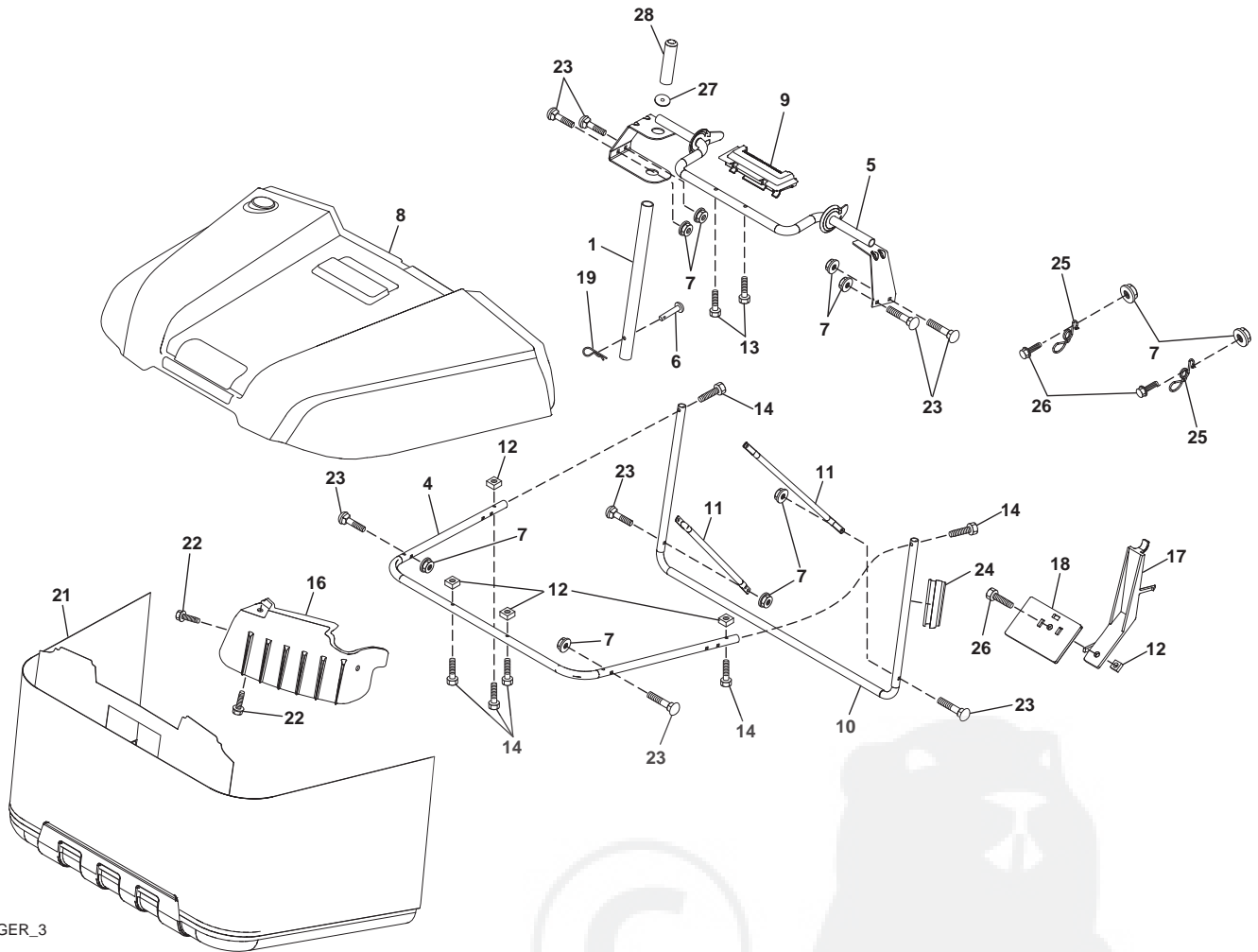

SRD_BAGGER_3

KEY NO.	PART NO.	DESCRIPTION	KEY NO.	PART NO.	DESCRIPTION
1	532 16 52-49	Tube Handle Bagger SRD	21	532 41 71-92	Bag Asm SRD
4	532 41 71-85	Frame Asm Bagger Top	22	532 14 24-32	Screw Hex WSH Hi-Lo 1/4 - 1/2 unc
5	532 41 76-32	Frame Asm Top Bagger SRD	23	872 04 04-10	Bolt Carr 1/4-20 unc x 1-1/4
6	532 12 68-75	Drilled Rivit	24	532 42 39-06	Extrusion
7	873 90 04-00	Nut Hex Flange 1/4-20 unc	25	532 42 16-14	Spring Latch Bagger
8	532 42 59-54	Cover Bagger SRD	26	817 49 04-12	Screw Hex Thdrol 1/4-20 x 3/4
9	532 41 76-29	Insert Handle Bagger	27	532 42 12-62	Grommet, Rubber SRD
10	532 41 71-90	Frame Front	28	532 16 57-87	Grip Handle Black
11	532 41 71-88	Tubing Brace Bagger			
12	532 42 17-93	Nut Square 1/4			
13	532 42 17-80	Screw 1/4 x 1.150 HXWSH			
14	532 42 18-00	Bolt Shoulder HX WSH 1/4 x 1.150			
16	532 42 15-66	Deflector Bagger			
17	532 42 17-49	Lever Bagger Full			
18	532 42 17-50	Paddle Bagger Full			
19	532 12 46-70	Retainer Spring			

NOTE: All component dimensions given in U.S. inches
1 inch = 25.4 mm