

REPAIR PARTS MANUAL
MODEL NO. LZ12592RB (96061004602)
Lawn Tractor

LAZER[®]

532 19 92-91 04.28.05 TR
PRINTED IN U.S.A.

HOW TO USE THIS MANUAL

This manual is designed to provide the customer with a means to identify the parts on his/her tractor when ordering repair parts. The illustrations may or may not represent the actual assemblies; therefore, it is not recommended to use this manual as a guide to assemble or disassemble the tractor. Some hardware and parts are drawn larger in order to more readily identify them.

Each tractor has its own model number.

The model number for your tractor can be found on the fender under the seat.

When ordering parts, always give the following information:

- Product - "Tractor"
- Model Number - LZ12592RB (96061004602)"
- Part Number
- Part Description

TABLE OF CONTENTS

SCHEMATIC	3
ELECTRICAL.....	4-5
CHASSIS.....	6-7
DRIVE.....	8-9
STEERING	10-11
SEAT	12
DECALS.....	13
ENGINE.....	14
MOWER LIFT.....	15
MOWER DECK	16-17
BAGGER.....	18

**TRACTOR - MODEL NO. LZ12592RB (96061004602), PRODUCT NO. 960 61 00-46
SCHEMATIC**

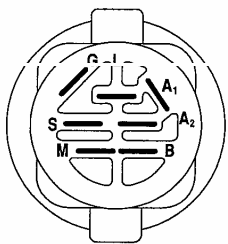
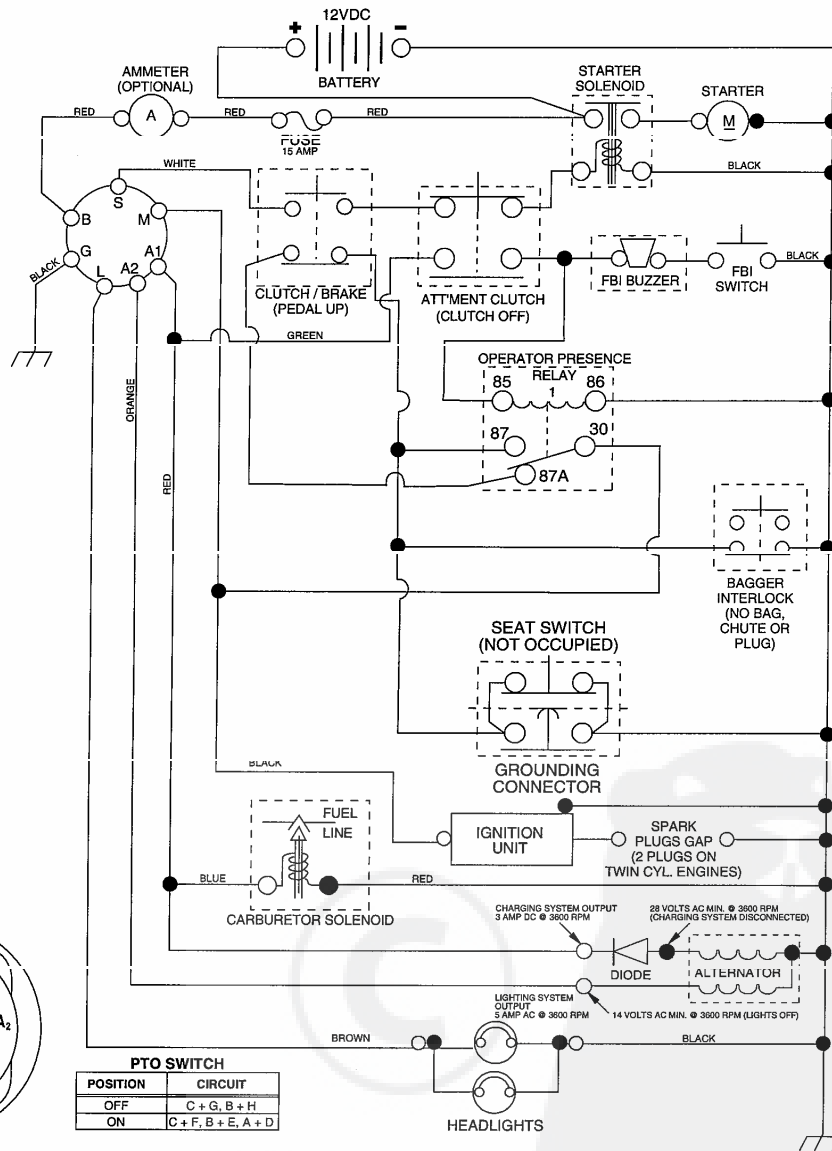

PTO SWITCH

POSITION	CIRCUIT
OFF	C + G, B + H
ON	C + F, B + E, A + D

IGNITION SWITCH

POSITION	CIRCUIT	"MAKE"
OFF	M+G+A1	NONE
RUN/LIGHT	B+A1	A2+L
RUN	B+A1	NONE
START	B + S + A1	NONE

WIRING INSULATED CLIPS
NOTE: IF WIRING INSULATED CLIPS WERE REMOVED FOR SERVICING OF UNIT, THEY SHOULD BE REPLACED TO PROPERLY SECURE YOUR WIRING.

02863

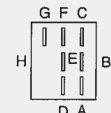
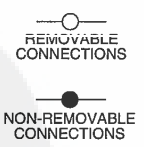

REPAIR PARTS

TRACTOR- -MODEL NO. LZ12592RB (96061004602), PRODUCT NO. 960 61 00-46
ELECTRICAL

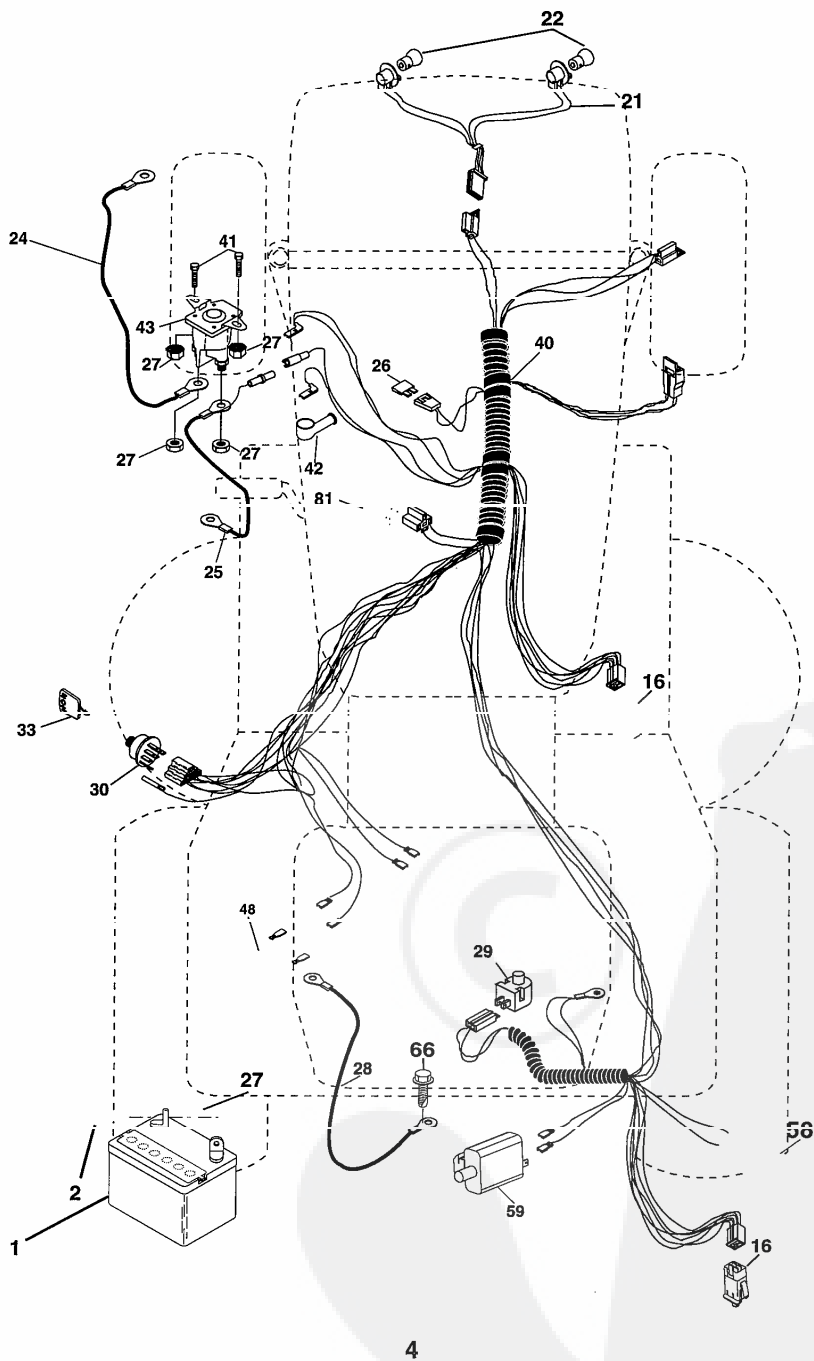

REPAIR PARTS

TRACTOR- -MODEL NO. LZ12592RB (96061004602), PRODUCT NO. 960 61 00-46
ELECTRICAL

KEY NO.	PART NO.	DESCRIPTION
1	532 16 34-65	Battery
2	874 76 04-12	Bolt Hex Hd 1/4-20 unc x 3/4
16	532 17 61-38	Switch Interlock Push-In
24	532 12 47-80	Cable Starter 6 Ga. 11" Red
25	532 16 59-87	Cable Battery Crd 56" Red
26	532 17 51-58	Fuse 20 Amp
27	873 51 04-00	Nut Keps Hex 1/4-20 unc
28	532 12 77-25	Cable Ground 6 Ga. 18" Black
29	532 12 13-05	Switch Plunger NC Gray
30	532 17 55-66	Switch Ignition
33	532 14 04-01	Key Ign
40	532 18 80-36	Harness Ign
41	871 11 04-08	Bolt Flk Fin Hex 1/4-20 unc x 1/2
42	532 13 15-63	Cover Terminal Red
43	532 17 88-61	Solenoid
48	532 14 08-44	Adapter Ammeter Rectangular
58	532 16 94-19	Buzzer Crd
59	532 18 03-79	Switch FBI CRD
66	817 49 06-08	Screw Thdrol 3/8-16 x 1/2 Ty-Tt
81	532 10 97-48	Relay Asm

NOTE: All component dimensions given in U.S. inches.
1 inch = 25.4 mm.

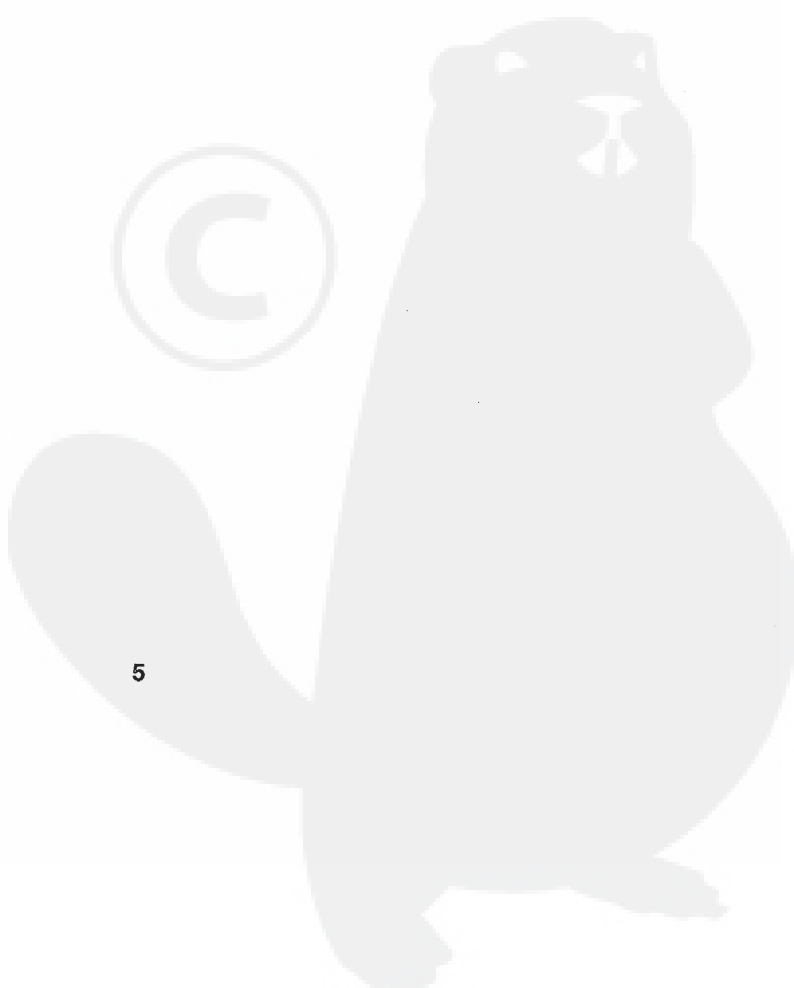

REPAIR PARTS

TRACTOR- -MODEL NO. LZ12592RB (96061004602), PRODUCT NO. 960 61 00-46
CHASSIS AND ENCLOSURES

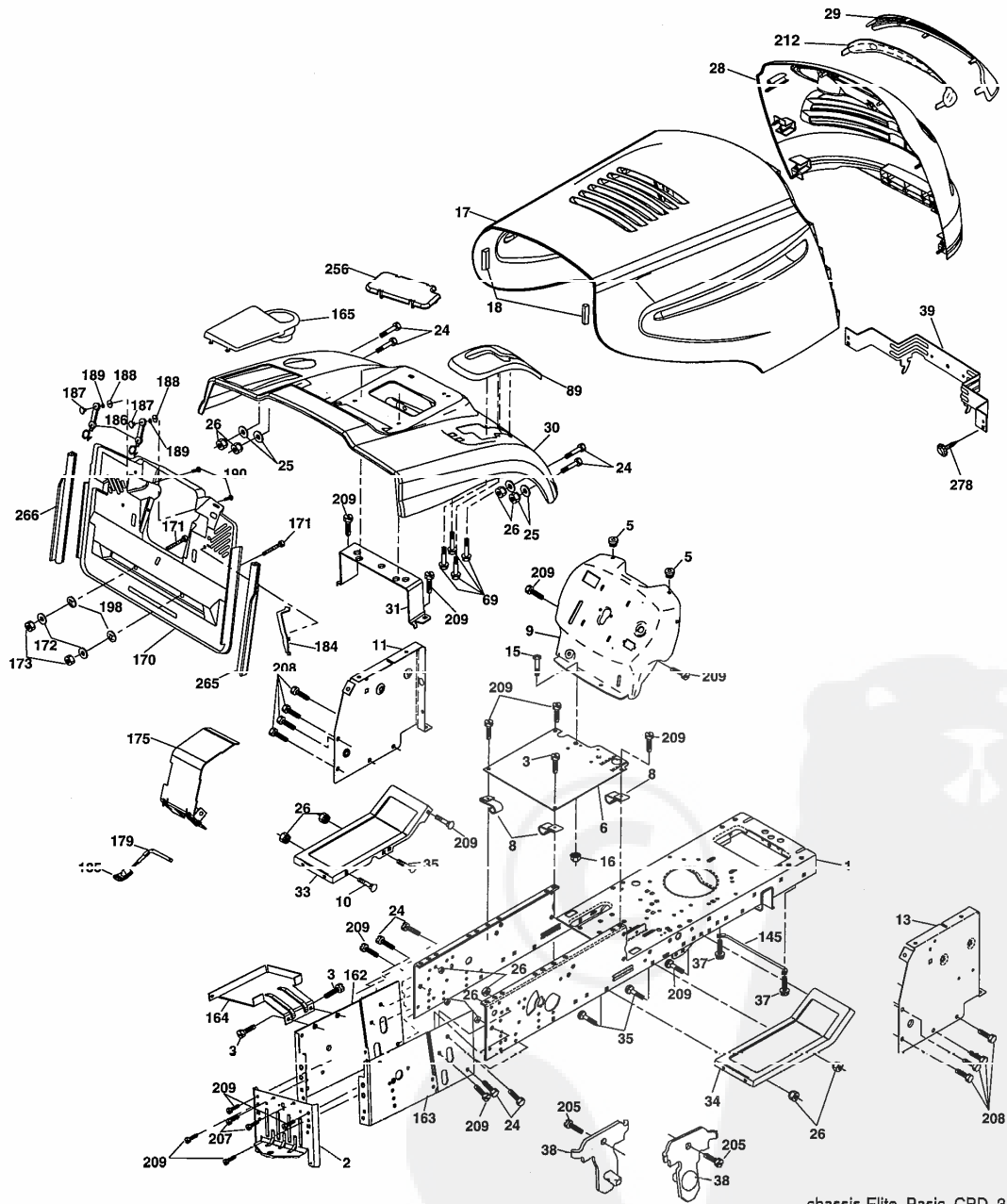

chassis-Elite_Basic_CRD_3

REPAIR PARTS

TRACTOR- -MODEL NO. LZ12592RB (96061004602), PRODUCT NO. 960 61 00-46
CHASSIS AND ENCLOSURES

KEY NO.	PART NO.	DESCRIPTION	KEY NO.	PART NO.	DESCRIPTION
1	532 17 46-20	Chassis	163	532 18 03-83	Bracket Exten Chassis Rh CRD
2	532 18 03-84	Drawbar	164	532 16 56-05	Support Battery CRD
3	817 06 06-12	Screw 3/8-16 x .75	165	532 18 13-56	Cover Battery CRD Lt
5	532 15 52-72	Bumper Hood/Dash	170	532 17 88-62	Backplate CRD
6	532 18 44-19	Saddle	171	872 14 06-20	Bolt Rdhd Sqnk 3/8-16 x 2-1/2 Gr. 5
8	532 12 64-71	Clip Insulator 13/32 Mtg. Hole	172	819 13 20-16	Washer 13/32 x 1-1/4 x 16 Ga.
9	532 19 46-88	Dash	173	873 51 06-00	Nut, Keps Hex 3/8-16 unc
10	872 14 06-08	Bolt, Carriage 3/8-16 x 3/4	175	532 18 82-03	Trap Door CRD
11	532 17 49-96	Panel, Dash, L.H.	179	532 18 82-02	Rod Pivot FBI CRD
13	532 18 69-52	Panel, Asm. Dash R.H.	184	532 17 46-62	Bracket Actuator Bagger CRD
15	874 18 05-12	Screw, Machine, Truss Head 5/16-18 unc x 3/4	195	532 19 11 01	Knob Rod
16	873 51 05-00	Nut	186	532 16 07-93	Latch Asm Multch Bagger
17	532 18 67-07	Hood Assembly	187	532 12 50-04	Nut Weld .327/.304 #10-24
18	532 18 49-21	Bumper Hood	188	819 06 12-16	Washer #10
24	874 78 06-16	Bolt	189	810 07 10-00	Washer Lock #10
25	819 13 13-12	Washer 13/32 x 13/16 x 12 Ga.	190	871 08 10-10	Screw Pan Hd Phillips 10-24 x 5/8
26	873 80 06-00	Nut	198	532 16 89-37	Nut Push
28	532 18 38-26	Grille Lens Asm (Include Key nos. 29 and 212)	205	817 49 06-08	Screw 3/8-16 x 1/2
29	532 18 98-37	Lens Grille Bar	207	817 67 05-08	Screw 5/16-18 x 1/2
30	532 19 73-44	Fender	208	817 67 06-08	Screw Thdrol 3/8-16 x 1/2
31	532 16 51-56	Bracket, Fender Support	209	817 00 06-12	Screw Hex vsin Tinuroi 3/8-16 x 3/4
33	532 18 11-93	Footrest, L.H.	212	532 18 38-23	Insert Lens Refl.
34	532 18 11-94	Footrest, R.H.	256	532 18 13-61	Cover Fender Rack CRD
35	872 11 06-06	Bolt	265	532 18 57-04	Seal RH Side Bagger
37	817 49 05-08	Screw Thdrol 5/16-18 x 1/2 TYT	266	532 18 57-03	Seal LH Side Bagger
38	532 18 17-48	Bracket Asm Pivot Mower Rear	278	532 19 16-11	Screw 10 x 3/4 Single Lead Hex
39	532 17 47-14	Bracket Pivot	--	532 00 54-79	Plug, Button
69	532 14 24-32	Screw Hex 1/4-1/2	--	532 19 39-35	Plug Switch Light
89	532 19 73-39	Console			
145	532 15 65-24	Rod Pivot Chassis/Hood			
162	532 18 03-82	Bracket Exten Chassis Lh CRD			

NOTE: All component dimensions given in U.S. inches.
1 inch = 25.4 mm.

REPAIR PARTS

TRACTOR- -MODEL NO. LZ12592RB (96061004602), PRODUCT NO. 960 61 00-46
DRIVE

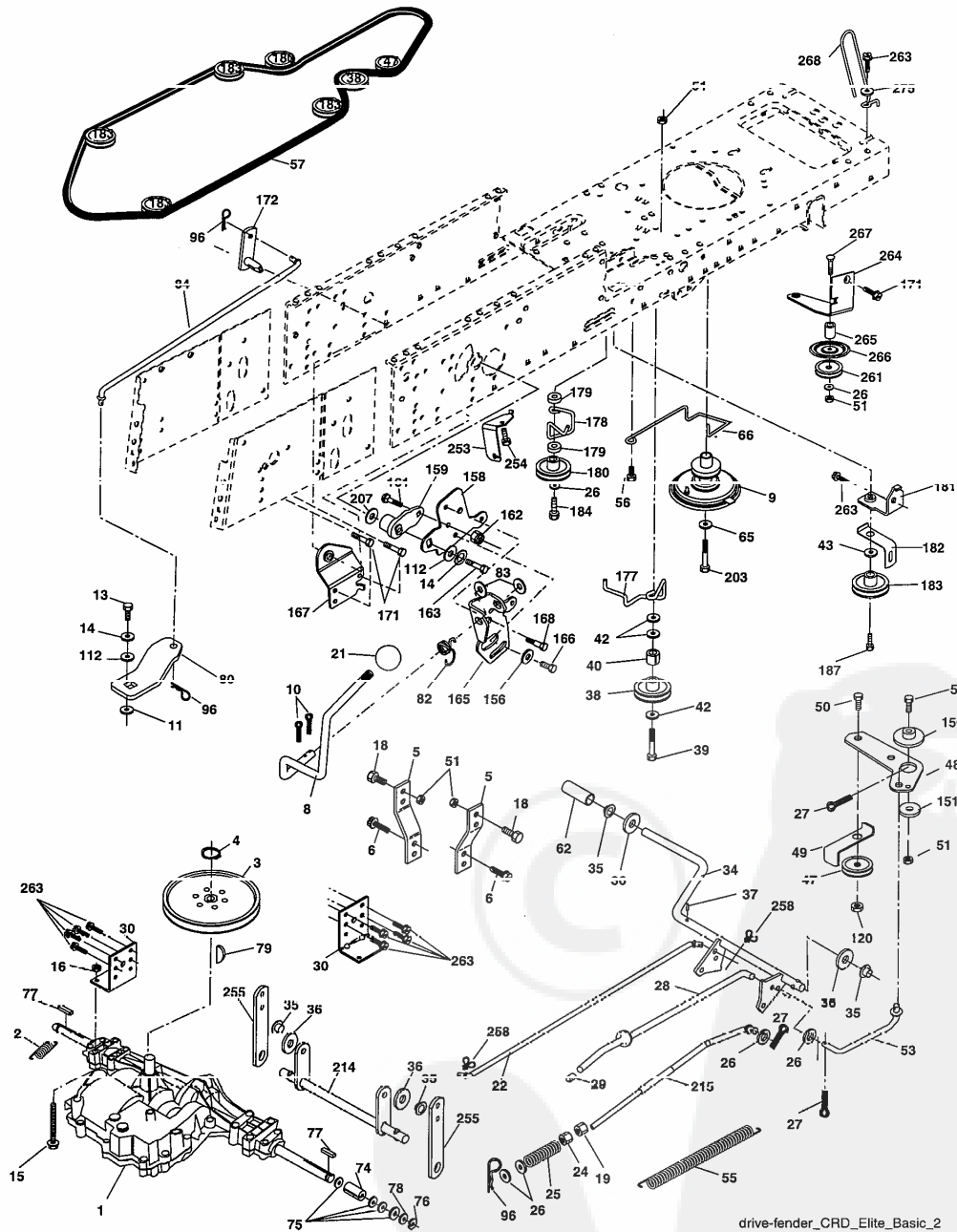

drive-fender_CRD_Elite_Basic_2

REPAIR PARTS

TRACTOR- -MODEL NO. LZ12592RB (96061004602), PRODUCT NO. 960 61 00-46
DRIVE

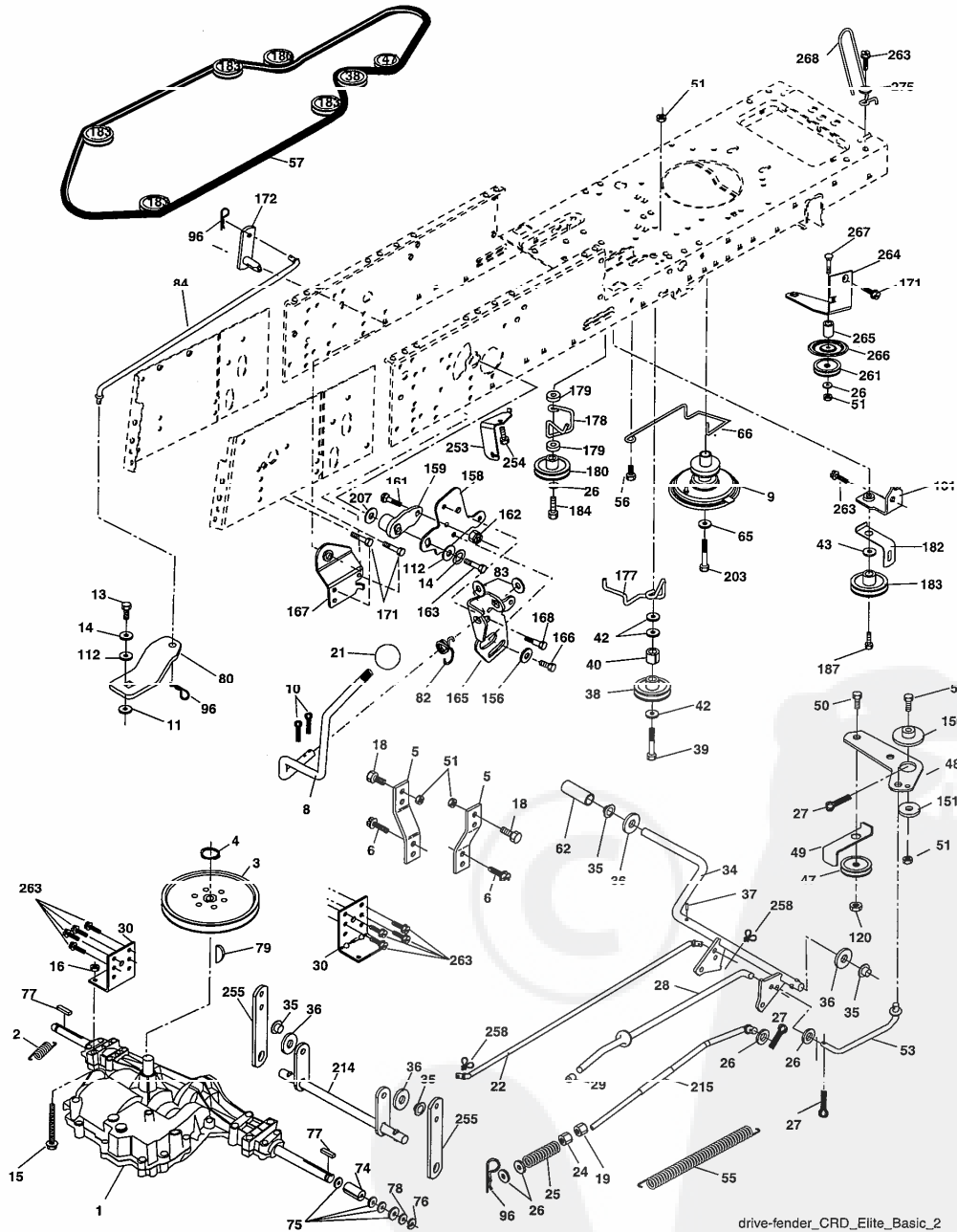

drive-fender_CRD_Elite_Basic_2

REPAIR PARTS

TRACTOR- -MODEL NO. LZ12592RB (96061004602), PRODUCT NO. 960 61 00-46
DRIVE

KEY NO.	PART NO.	DESCRIPTION	KEY NO.	PART NO.	DESCRIPTION
1	-----	Transaxle Peerless 206-546 Order parts from transaxle manufacturer	79	532 12 50-96	Key Woodruff
2	532 14 66-82	Spring Brake Return	80	532 14 50-90	Arm Shift PMST 20" Tires
3	532 16 59-99	Pulley Transaxle	82	532 16 57-11	Spring, Torsion
4	812 00 00-28	Ring Retainer #5100-62	83	819 17 12-16	Washer 17/32 x 3/4 x 16 Ga.
5	532 12 15-20	Strap torque 30 degrees	84	532 16 56-21	Link Shift CRD Pmst 18" Tires
6	817 06 05-12	Screw 5/16-18 x 3/4	96	532 12 47-88	Spring, Retainer 1"
8	532 16 56-19	Rod Shift Fender Adjust Lt	112	819 09 12-10	Washer 9/32 x 3/4 x 10 Ga.
9	532 18 03-54	Clutch Asm Noram	120	873 90 06-00	Nut Lock 3/8-16
10	876 02 04-16	Pin, Cotter 1/8 x 1	150	532 16 58-50	Bushing, Bellcrank Grnd Dr
11	532 10 57-01	Washer Plate Shf .3888 sq hole	151	819 13 32-10	Washer 13/32 x 2 x 10 Ga.
13	874 55 04-12	Bolt 1/4-28 unf Gr. 8 w/patch	156	532 16 60-02	Washer Srrd 5/16 ID x 1.125
14	810 04 04-00	Washer, Lock Hvy Helical	158	532 16 55-89	Bracket Shift Mount
15	874 49 05-44	Bolt Hex FGHD 5/16-18 x Gr. 5	159	532 18 39-00	Hub Tapered Flange Shift Lt
16	873 80 05-00	Nut, Lock Hex w/Ins 5/16-18 unc	161	872 14 04-06	Bolt Rdhd Sqnk 1/4-20 x 3/4 Gr 5
18	874 78 06-16	Bolt Hex 3/8-16 UNC x 1 Gr. 5	162	873 68 04-00	Nut Crownlock 1/4-20 unc
19	873 80 06-00	Nut, Lock Hex w/Wsh 3/8-16 unc	163	874 78 04-16	Bolt Hex Fin 1/4-20 unc x 1 Gr 5
21	532 10 69-33	Knob Round 1/2-13 unc Blk	165	532 16 56-23	Bracket Pivot Lever
22	532 17 56-07	Rod, Brake CRD Main	166	817 49 05-10	Screw 5/16-18 x 5/8
24	873 35 06-00	Nut	167	532 16 55-88	Bracket Support Shift CRD
25	532 10 00-00	Spring, Rod, Brake	168	532 16 54-92	Bolt Shoulder 5/16-18 x .561
26	819 13 13-16	Washer 13/32 x 13/16 x 16 Ga.	171	817 49 06-08	Screw Thdrol 3/8-16 x 1/2 Ty-Tt
27	876 02 04-12	Pin, Cotter 1/8 x 3/4	172	532 10 50-35	Shaft Asm Shift Front CRD FIMST
28	532 17 57-65	Rod, Parking Brake	177	532 16 59-32	Keeper Flat Idler 3.06" CRD
29	532 07 16-73	Cap, Parking Brake	178	532 16 59-33	Keeper Belt Idler 1.88" CRD
30	532 17 49-73	Bracket, Mfg. Transaxle	179	532 12 09-58	Washer Sintered
34	532 17 55-78	Shaft, Asm Pedal Foot CRD	180	532 16 56-30	Pulley Flat Composite 3.06"
35	532 12 01-83	Bearing, Nylon	181	532 18 02-11	Bracket Idler Ground Drive CRD
36	819 21 16-16	Washer 21/32 x 1 x 16 Ga.	182	532 18 26-82	Keeper Belt 2.5" Od V-Idler CRD
37	532 12 49-63	Pin, Roll 3/16 x 1"	183	532 18 60-07	Pulley V-Idler 2.50" Od CRD
38	532 16 59-36	Pulley, Flat	184	817 49 06-44	Screw Hex wsh Thdrol 3/8-16 x 2-3/4
39	874 76 06-44	Bolt Fin Hex 3/8-16 unc x 2-3/4	187	817 58 05-20	Screw 5/16-18 x 1.25
40	532 12 49-65	Spacer, Split 395 x 59 Bzp	203	871 17 07-80	Bolt Hex 7/16-20 x 5
42	819 13 13-12	Washer 13/32 x 13/16 x 12 Ga.	207	532 16 98-45	Washer Nylon
43	819 11 10-12	Washer 11/32 x 5/8 x 12 Ga.	214	532 17 56-09	Shaft Asm. Brake
47	532 12 77-83	Pulley, Idler, V Groove Plastic	215	532 17 56-51	Rod Brake Secondary
48	532 15 44-07	Bellcrank Clutch Grnd Drv	253	532 17 50-28	Bracket Cable Chassis
49	532 12 32-05	Retainer, Belt Style Spring	254	817 00 06-16	Screw 3/8-16 x 1
50	872 11 06-12	Bolt Carr Sh 3/8-16 x 1-1/2 Gr. 5	255	532 17 56-08	Brace Shaft Brake
51	873 68 06-00	Nut, Crownlock 3/8-16 unc	258	532 17 80-62	Clip Retainer
53	532 10 57-10	Link, Clutch 7.66	261	532 13 14-04	Pulley Idler Flat Plated
55	532 10 57-09	Spring, Return, Clutch	263	817 00 06-12	Screw Hex Wsh THDR 3/8-16 x 3/4
56	817 06 06-20	Screw 3/8-16 x 1-1/4	264	532 18 19-95	Bracket Clutch
57	532 16 56-31	V-Belt Kev PMST CRD	265	532 18 20-13	Spacer Idler Chassis
62	532 12 48-72	Cover, Pedal	266	532 18 20-61	Shield Idler
65	810 04 07-00	Washer	267	872 14 06-26	Bolt Rd Sqk 3/8-16 x 3-1/4
66	532 15 47-78	Keeper, Belt Engine F-Proof	268	532 18 24-02	Guard Muffler OHV B&S RH
74	532 13 70-57	Spacer Axle	275	819 13 16-14	Washer 13/32 x 1 x 14 Ga.
75	532 12 17-49	Washer 25/32 x 1-1/4 x 16 Ga.			
76	912 00 00 01	Ring, E			
77	532 12 35-83	Key, Square			
78	532 12 17-48	Washer 25/32 x 1-5/8 x 16 Ga.			

NOTE: All component dimensions given in U.S. inches
1 inch = 25.4 mm

REPAIR PARTS

TRACTOR- -MODEL NO. LZ12592RB (96061004602), PRODUCT NO. 960 61 00-46
STEERING ASSEMBLY

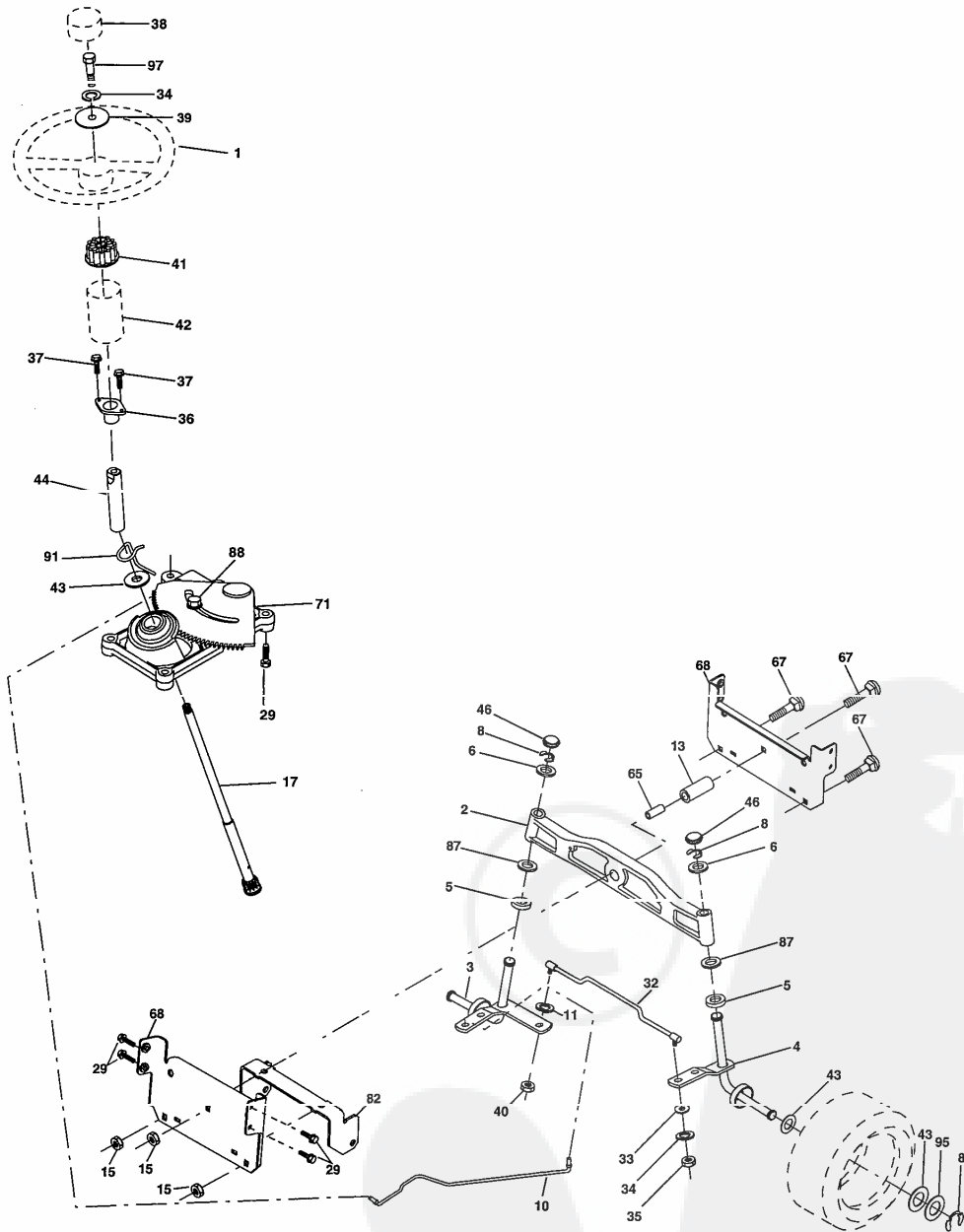

steering_pl.it_60

REPAIR PARTS

TRACTOR- -MODEL NO. LZ12592RB (96061004602), PRODUCT NO. 960 61 00-46
STEERING ASSEMBLY

KEY NO.	PART NO.	DESCRIPTION
1	532 18 67-80	Steering Wheel
2	532 18 47-06	Cast Iron Axle Assembly
3	532 16 98-40	Spindle Assembly, L.H.
4	532 16 98-39	Spindle Assembly, R.H.
5	532 12 49-31	Bearing, Race, Thrust, Hardened
6	532 12 17-48	Washer 25/32 x 1-5/8 x 16 Ga.
8	812 00 00-29	Ring, Klip
10	532 17 51-21	Link, Drag
11	810 04 06-00	Washer, Lock
13	532 13 65-18	Spacer Brg Axle Front
15	532 14 52-12	Nut, Hexflange Lock
17	532 19 07-53	Shaft Assembly, Steering
29	817 00 06-12	Screw, 3/8-16 x 3/4
32	532 17 01-62	Rod, Tie
33	819 11 12-16	Washer 11/32 x 3/4 x 16 Ga.
34	810 04 05-00	Washer Lock Hvy Hlcl Spr 5/16
35	873 54 05-00	Nut Crownlock 5/16-24 unf
36	532 15 50-33	Bushing, Steering
37	532 15 29-27	Screw TT #10-32 x 5 x 3/8 Flange
38	532 19 29-16	Cap Wheel Steer
39	819 11 38-12	Washer 11/32 x 2-3/8 x 12 Ga.
40	873 54 06-00	Nut Crownlock 3/8-24
41	532 18 67-37	Adaptor, Steering Wheel
42	532 16 96-33	Boot, Steering Dash P/L Mtl
43	532 12 17-49	Washer 25/32 x 1-1/4 x 16 Ga.
44	532 19 07-52	Extension Steering
46	532 12 12-32	Cap, Spindle
65	532 16 03-67	Spacer Brace Axle
67	872 11 06-18	Bolt Rdhd Sq 3/8-16 unc x 2-1/4
71	532 17 51-46	Steering Asm.
68	532 16 98-27	Brace Axle
82	532 16 98-35	Bracket Susp Chassis Front
87	532 17 39-66	Washer Flat .781 x 1-1/2 x .14
88	532 17 51-18	Bolt Shoulder 7/16-20 unc
91	532 17 55-53	Clip Steering
95	532 18 89-67	Washer Harden .793 x 1.637 x 060
97	874 78 05-64	Bolt 5/16-18 unc x 4" Gr 5

NOTE: All component dimensions given in U.S. inches.
1 inch = 25.4 mm.

REPAIR PARTS

TRACTOR- -MODEL NO. LZ12592RB (96061004602), PRODUCT NO. 960 61 00-46
SEAT ASSEMBLY

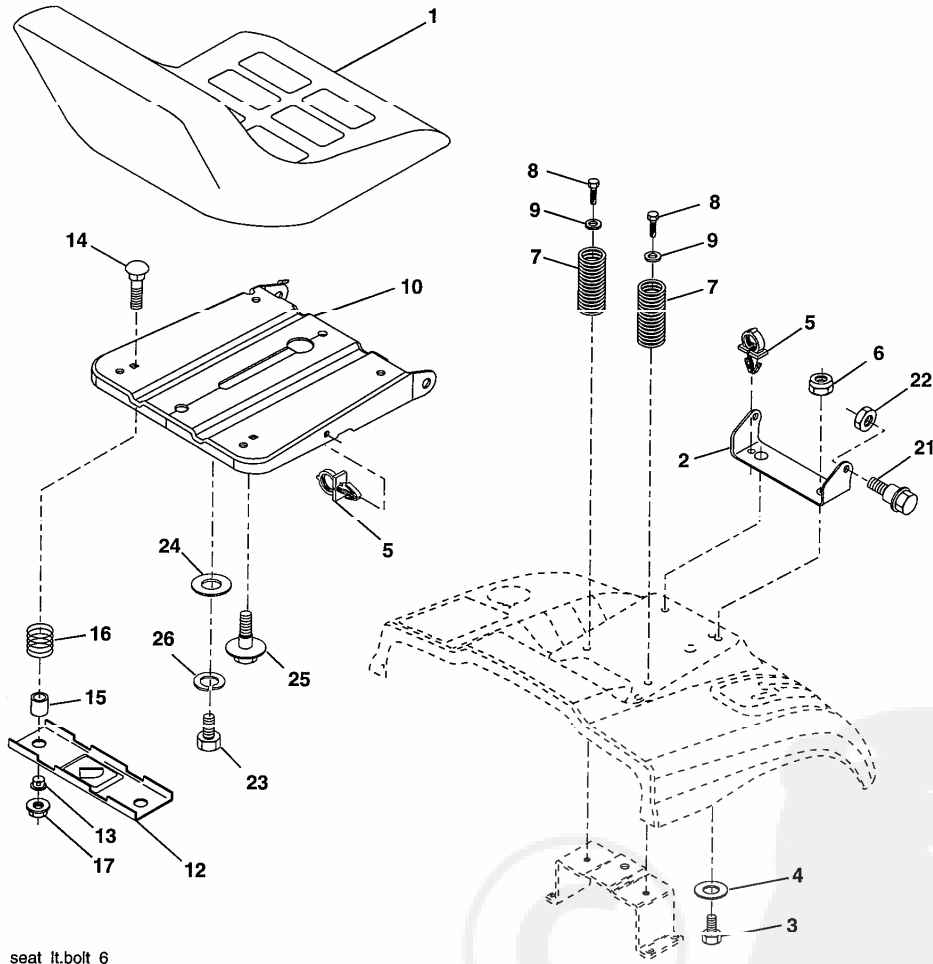

seat_lt.bolt_6

KEY PART NO.

KEY NO.	PART NO.	DESCRIPTION
1	532 18 87-04	Seat
2	532 18 01-66	Bracket Pnt Pivot Seat (blk)
3	871 11 06-16	Bolt Fin Hex 3/8-16 unc x 1
4	819 13 16-10	Washer Flat 13/32 x 1 x 10 Ga.
5	532 14 50-06	Clip Push In l linged
6	873 80 06-00	Nut Lock Hex 3/8-16 unc
7	532 12 41-81	Spring Seat Cprsn 2 250 Blk 7i
8	817 00 06-16	Screw 3/8-16 x 1-1/2
9	819 13 16-14	Washer 13/32 x 1 x 14 Ga.
10	532 18 01-86	Pan Pnt Seat (blk)
12	532 12 12-46	Bracket Pnt Mounting Switch
13	532 12 12-48	Bushing Snap Blk Nyl 50 Id

KEY PART NO.

KEY NO.	PART NO.	DESCRIPTION
14	872 05 04-12	Bolt Rdhd Sht Nk 1/4-20 x 1-1/2
15	532 13 43-00	Spacer Split
16	532 12 12-50	Spring Cprsn Plate SW 1.3 10 Ga.
17	532 12 39-76	Nut Lock 1/4 Lge Flg Gr. 5 Zinc
21	532 17 18-52	Bolt Shoulder 5/16-18 unc-2A
22	873 80 05-00	Nut Hex Lock w/Ins 5/16-18
23	871 11 08-14	Bolt Hex Black
24	819 17 19-12	Washer 17/32 x 1-3/16 x 12 Ga.
25	532 12 70-18	Bolt Shoulder 5/16-18 x 62
26	810 04 08-00	Washer Lock Hvy Hlcl Spr 1/2

NOTE: All component dimensions given in U.S. inches.
1 inch = 25.4 mm

REPAIR PARTS

TRACTOR- -MODEL NO. LZ12592RB (96061004602), PRODUCT NO. 960 61 00-46
DECALS

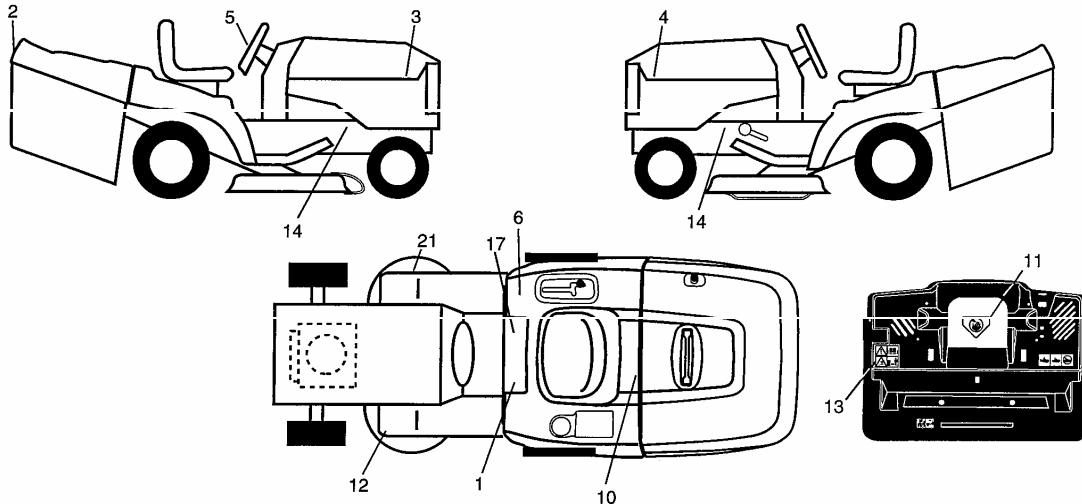

KEY NO.	PART NO.	DESCRIPTION
1	532 14 54-98	Decal Read Owner's Manual Sym
2	532 19 56-99	Decal Fender
3	532 19 57-00	Decal Hood RH
4	532 19 57-01	Decal Hood LH
5	532 19 56-98	Decal Strg. Wheel
6	532 18 04-32	Decal Fender 100 OB/CE
10	532 14 50-05	Decal Bat Dan/Poi P/L Sym Wpn
11	532 18 21-66	Decal Mower Cut Finger Symbol
12	532 15 97-37	Decal Brake/Clutch Symbol Lt
13	532 18 04-35	Decal Warn Back Plate CRD

KEY NO.	PART NO.	DESCRIPTION
14	532 15 97-36	Decal Chassis Hot Muffler
17	532 14 08-37	Decal Saddle Brake Parking
21	532 16 62-86	Decal Hex Belt Sch 92 CRD
--	532 18 10-90	Pad Footrest RH
--	532 13 83-11	Decal Lift Handle
--	532 18 26-21	Decal Bagger Frame
--	532 18 10-91	Pad Footrest LH
--	532 19 68-48	Manual Operator's (Euro)
--	532 19 68-49	Manual Operator's (Scan)
--	532 19 92-91	Manual Parts

WHEELS & TIRES

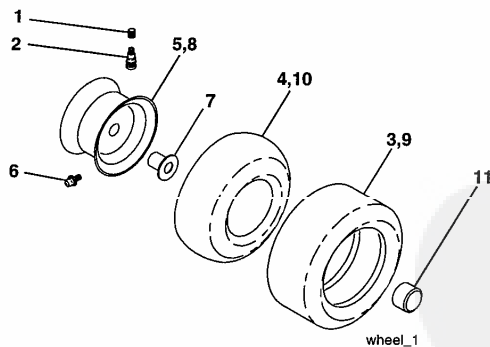

KEY NO.	PART NO.	DESCRIPTION
1	532 05 91-92	Cap Valve Tire
2	532 06 51-39	Stem Valve
3	532 12 41-57	Tire F Ts 15 x 6 0 - 6 Service
4	532 05 99-04	Tube Inner Front #35060
5	532 18 33-37	Rim Asm 6" front Service
6	532 12 49-57	Fitting Grease
7	532 12 49-59	Bearing Flange
8	532 18 33-38	Rim Asm 8" rear Service
9	532 12 33-63	Tire R Ts 16 x 9.5-8 C. Service
10	532 12 49-26	Tube Rear 9 5 x 8 Service
11	532 17 50-39	Cap Axle Blk 1 50 x 1 00
--	532 14 43-34	Sealant, Tire (10 oz. tube)

NOTE: All component dimensions given in U.S. inches
1 inch = 25.4 mm

REPAIR PARTS

TRACTOR- -MODEL NO. LZ12592RB (96061004602), PRODUCT NO. 960 61 00-46
ENGINE

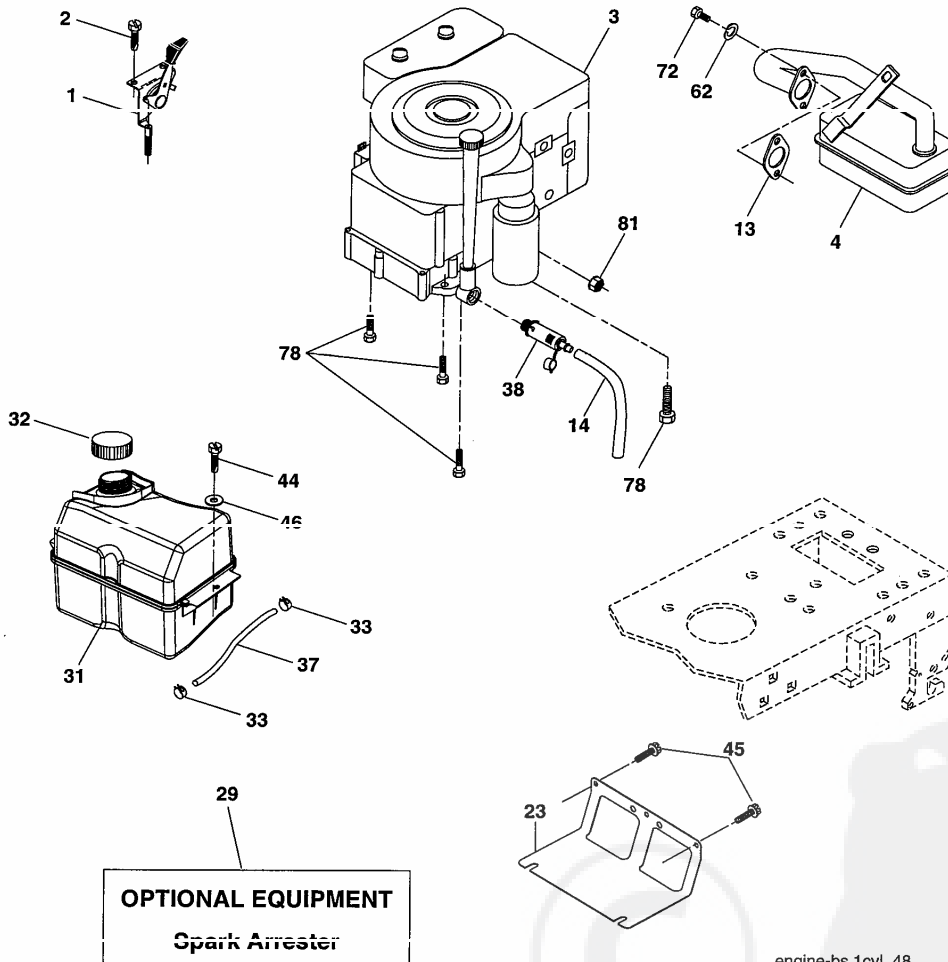

engine-bs.1cyl_48

KEY NO.	PART NO.	DESCRIPTION
1	532 17 08-64	Control Throttle /Choke
2	817 72 04-08	Screw Hex Thd Cut 1/4-20 x 5/8 T
3	-----	Engine B&S Model 219707 (Order Parts from Engine Manufacturer)
4	532 17 97-58	Muffler Exhaust
13	532 16 52-91	Gasket
14	532 14 84-56	Tube Drain Oil Easy
23	532 16 98-37	Shield Browning/Debris Guard
29	532 13 71-80	Arrestor Spark
31	532 18 55-34	Tank Fuel
32	532 14 05-27	Cap Asm Fule Top Vent N/Lany
33	532 12 34-87	Clamp Hose Blk

KEY NO.	PART NO.	DESCRIPTION
37	532 13 70-40	Line Fuel 20"
38	532 18 16-54	Plug Drain Oil Easy
44	817 67 04-12	Screw Hexwsh Thdrol 3/8-16 x 3/4
45	817 00 00-12	Screw 3/8-16 x 3/4
46	819 09 14-16	Washer 9/32 x 7/8 x 16 Ga.
62	810 04 05-00	Washer Lock Hvy HLCL Spr 5/16
72	871 07 05-12	Screw Hex HD Cap 5/16-18 x 3/4
78	817 06 06-20	Screw 3/8-16 x 1-1/4
81	873 51 04-00	Nut Keps Hex 1/4-20 unc

NOTE: All component dimensions given in U.S. inches
1 inch = 25.4 mm

REPAIR PARTS

TRACTOR- -MODEL NO. LZ12592RB (96061004602), PRODUCT NO. 960 61 00-46
MOWER LIFT

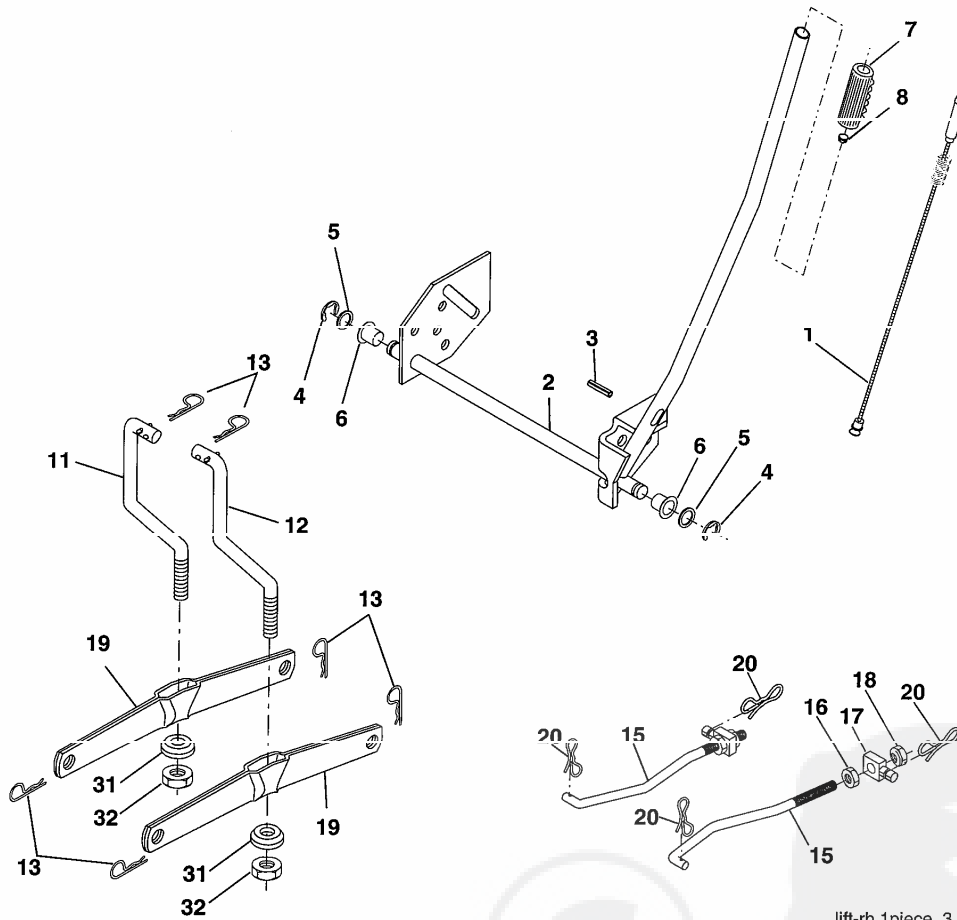

KEY NO.	PART NO.	DESCRIPTION
1	532 19 84-17	Washer Asm Inner Spring W/ Plunger
2	532 19 80-70	Shaft Asm. Lift
3	532 18 88-22	Pin Groove
4	812 00 00-02	E Ring #5133-62
5	819 21 16-21	Washer 21/32 x 1 x 21 Ga.
6	532 12 01-83	Bearing Nylon
7	532 10 94-13	Grip Handle Bicycle
8	532 12 45-26	Button Plunger Black
11	532 16 58-29	Link Asm Lift L.H.
12	532 16 58-31	Link Asm Lift R.H.

KEY NO.	PART NO.	DESCRIPTION
13	532 12 46-70	Retainer Spring
15	532 17 32-88	Link Front
16	873 35 08-00	Nut Jam Hex 1/2-13 unc
17	532 17 56-89	Trunnion Blk Zinc
18	873 80 08-00	Nut Lock w/Wsh 1/2-13 unc
19	532 13 98-68	Arm Suspension Mower
20	532 19 42-09	Pin Cotter 7/16 Bow Tie Lock
31	532 16 98-65	Bearing, Pvt. Lift.
32	873 54 06-00	Nut Crownlock 3/8-24

NOTE: All component dimensions given in U.S. inches
1 inch = 25.4 mm

REPAIR PARTS

TRACTOR- -MODEL NO. LZ12592RB (96061004602), PRODUCT NO. 960 61 00-46
MOWER

KEY NO.	PART NO.	DESCRIPTION
1	532 16 55-52	Housing Asm. Mower
2	872 14 05-06	Bolt Rdhd Sqnk 5/16-18 unc x 3/4
3	532 16 55-69	Bracket Asm. S-Bar Chass
4	532 16 55-58	Bracket Bar Sway Deck
5	532 12 46-70	Retainer Spring
6	532 16 55-57	Bar Sway
8	532 18 17 12	Bolt 3/8 24 x 1.25 Gr. 8 Patchrod
9	810 03 06-00	Washer Lock Hvy 3/8 Unplated
11	532 18 63-85	Blade 3-1 Lh
13	532 13 76-45	Shaft Asm. W/Lower Bearing
14	532 12 87-74	Housing Mandrel Vented (Machd)
15	532 11 04-85	Bearing Ball Mandrel
16	532 18 63-86	Blade 3-1 Rh
17	872 14 06-10	Bolt Carriage 3/8-16 x 1-1/4
18	872 11 06-06	Bolt Rdhd Sqnk 3/8-16 x 3/4
19	532 13 28-27	Bolt Shoulder 5/16-18 Thd Form
20	532 18 17-13	Bolt 3/8-24 x 1.25 Gr. 8 Patch Rod
21	873 68 05-00	Nut Crown Lock 5/16-18
22	532 16 52-43	Bracket Idler Sprt RR
23	532 16 54-46	Bracket Idler Sprt RF
24	532 16 52-42	Bracket Suspension LF
25	532 16 52-44	Bracket Suspension RF
26	532 16 52-37	Brace Support Susp Frt CRD
27	532 16 55-68	Bracket Asm. Susp RR
28	532 16 55-67	Bracket Asm. Susp LR
30	532 17 39-84	Screw Thd Rolling Washer Head
31	532 18 76-90	Washer Spacer
32	532 15 35-31	Mandrel Pulleys 36 & 46
33	532 17 83-42	Nut Flg Top Lock
34	532 16 52-39	Bracket Gauge Wheel Lf
35	532 16 52-38	Bracket Gauge Wheel Rf
36	532 14 67-63	Pulley Idler V-Groove Dim 4.25
40	873 68 06-00	Nut Crownlock 3/8-16 unc
41	873 90 06-00	Nut Lock FLg 3/8-16 unc
44	532 17 55-38	Cover Mandrel Lh

KEY NO.	PART NO.	DESCRIPTION
45	532 17 55-39	Cover Mandrel Rh
46	532 13 77-29	Screw Thd Roll 1/4-20 x 5/8
55	532 16 54-45	Arm Idler
56	532 16 57-23	Spacer Retainer PM Mower
61	532 16 59-45	Spring Tension Belt
67	532 10 69-32	Knob Rd 3/8-16 Plstc Thds Blk
68	532 18 02-17	Hex-Delt 32 Mower
69	532 16 54-82	Shaft Asm W/Lwr Brg Rh Thd CRD
84	532 15 60-85	Keeper Belt Idler
116	532 18 42-19	Bolt Shoulder
117	532 13 39-57	Wheel Gage Donut Wide
118	873 93 06-00	Nut Centerlock 3/8-16 unc
119	819 12 14-14	Washer 3/8 x 7/8 x 14 Ga.
124	872 11 06-12	Bolt Carr Sh 3/8-16 x 1-1/2 Gr. 5
130	872 11 05-06	Bolt Rdhd sqnk 5/16-18 unc x 3/4
131	532 16 56-61	Chute Bagger CHD
152	532 17 60-74	Cable Clutch CRD Service
158	817 72 04-08	Screw Hex Thdcut 1/4-20 x 5/8
161	532 18 63-87	Blade Cross Lh 92
162	532 18 08-78	Adpater Blade Cross
163	532 18 63-88	Blade Cross Rh 92
185	532 18 82-34	Head Asm Cable Clutch
--	532 18 18-57	Mandrel Asm Service
--	532 18 18-58	Mandrel Asm CRD Lh Threads SVC
--	532 18 85-23	Replacement Mower Complete (Std. deck order separately gauge wheel components key nos. 116-119)

NOTE: All component dimensions given in U.S. inches
1 inch = 25.4 mm

REPAIR PARTS

TRACTOR- -MODEL NO. LZ12592RB (96061004602), PRODUCT NO. 960 61 00-46
BAGGER

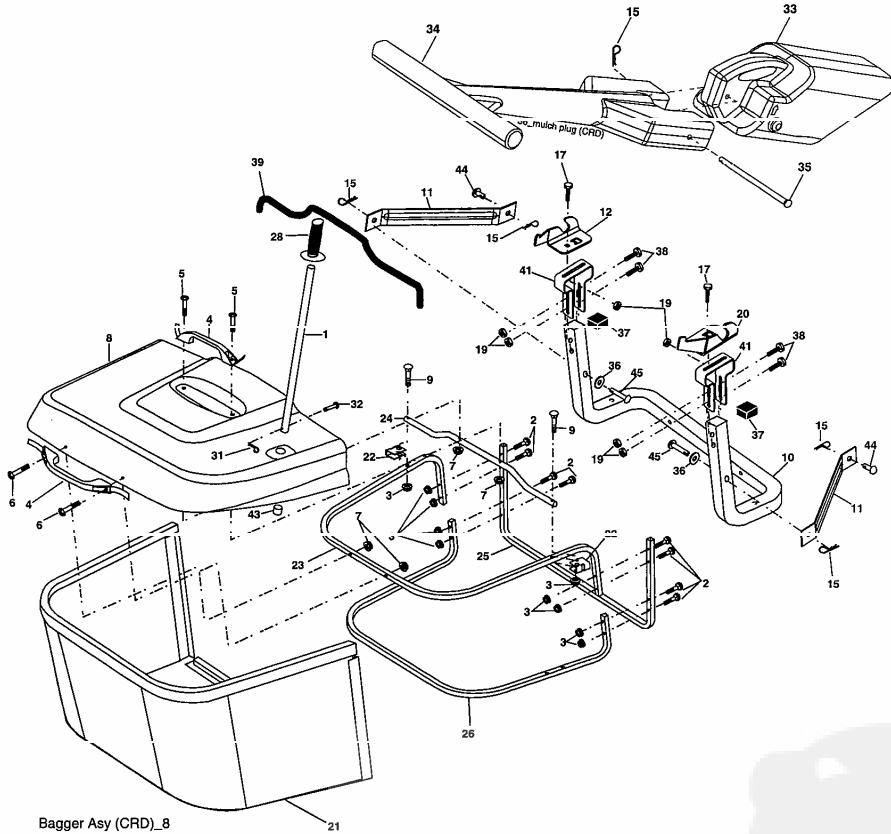

Bagger Asy (CRD)_8

KEY NO.	PART NO.	DESCRIPTION
1	532 16 52-49	Tube Handle Bagger CRD
2	872 14 04-16	Bolt Carriage 1/4-20 x 2.0 Gr. 5
3	532 12 33-70	Nut Lock 1/4 Lge Fig Cr. 5 Zinc
4	532 16 99-16	Handle Bagger w/Lvrs Gr. 5 Zinc
5	874 98 10-24	Screw Pan Head #10-24 x 1.50
6	874 98 10-32	Screw Pan Hd
7	873 40 10-00	Nut Wiz Lock Hex Serr/Hd #10-24
8	532 18 13-54	Cover Bagger Steel
9	872 14 04-18	Bolt Carriage 1/4-20 x 2.25d x Gr.5
10	532 18 12-82	Tube Support Bagger CRD
11	532 16 57-19	Bracket Support Upper Bag CRD
12	532 18 88-48	Bracket Pivot LH
13	872 11 06-06	Bolt Rdhd Sht Sqnk 3/8-16 x 3/4
14	874 52 06-36	Bolt Hex 3/8-16 X 2-1/4 Gr. 5
15	532 12 46-70	Retainer Spring
16	873 90 06-00	Nut Lock Fig 3/8-16 unc
17	872 14 05-06	Bolt Rdhd Sht Sqnk 5/16-18 unc x 3/4
19	873 90 05-00	Nut Lock Hex Flange 5/16-18
20	532 18 88-47	Bracket Pivot RH
21	532 18 08-80	Bag Asm CRD

KEY NO.	PART NO.	DESCRIPTION
22	532 16 57-81	Bracket Side Bagger CRD
23	532 16 57-82	Tube Upper Bagger CRD
24	532 16 57 93	Tube Pivot Bagger CRD
25	532 18 01-24	Tube Front Bagger CRD
26	532 16 57-85	Tube Lower Bagger CRD
28	532 16 57-87	Grip Handle Black
31	532 16 94-84	Retainer Clip
32	532 12 68-75	Rivet Rd Hd Drilled 3/8 Dia
33	532 16 55-71	Plug Mulcher
34	532 16 55-70	Handle Mulcher
35	532 16 55-72	Pin Mulcher
36	819 13 20-12	Washer 13/32 x 1-1/4 x 12 Ga.
37	532 17 54-01	Flng Support Bagger CRD
38	872 01 05-20	Bolt 5/16-18 x 2-1/2
39	532 18 09-85	Seal Trim 37"
41	532 16 96-83	Bracket Vert Adj Bagger CRD
43	532 17 40-83	Plug Tubing End
44	532 19 33-12	Pin Clevis 3/8 x 11/16
45	532 19 33-13	Pin Clevis 3/8 x 2.00

NOTE: All component dimensions given in U.S. inches
1 inch = 25.4 mm



TECUMSEH

SERVICE POLICY WARRANTY



TECUMSEH

Issued January 1980
Revised January 1991

LIMITED WARRANTIES FOR NEW PEERLESS GEAR POWER TRAIN COMPONENTS

A. Products Warranted

Peerless Gear and Machine Division of Tecumseh Products Company ("Tecumseh"), subject to the limitations contained below, will, at its option, repair or replace, without charge for parts or labor only, any part of a new Power Train Component (which as used herein means and includes the transaxle, gear box, transmission, differential and right angle drives, and any part of the Power Train Component), EXCEPT any new Power Train Component incorporated in equipment used for commercial or rental purposes, which is found upon examination by any Tecumseh Authorized Service Outlet or by Tecumseh's factory in Grafton, Wisconsin, to be DEFECTIVE IN MATERIAL AND/OR WORKMANSHIP if received by Tecumseh or a Tecumseh Authorized Service Outlet for such examination within TWO YEARS from the date of sale to the original consumer purchaser of Peerless Series 820, 900, 910, 915, 920, 930 transaxles and Series 1100 angle drive and ONE YEAR for all other Peerless products. New Power Train Components incorporated in equipment used for commercial purposes are warranted in the same manner and to the same extent EXCEPT such Power Train Components are warranted for NINETY (90) DAYS ONLY, and must be received by Tecumseh or by a Tecumseh Authorized Service Outlet for such examination within 90 days from the date of sale to the original purchaser. New Power Train Components Incorporated in equipment used for rental purposes are warranted in the same manner and to the same extent EXCEPT such Power Train Components are warranted for THIRTY (30) DAYS ONLY, and must be received by Tecumseh or a Tecumseh Authorized Service Outlet within 30 days from the date of sale to the original purchaser.

B. Products And Items Not Warranted

1. Alterations or Modifications of Power Train Components.
2. Accidents, Normal Maintenance, Failure to follow the Original Equipment Manufacturer's Manual.

This warranty covers only parts of new Power Train Components which are found upon examination to be defective in material or workmanship as delivered to the original purchaser. This warranty does not cover defects caused by depreciation or damage caused by normal wear, accidents, improper maintenance, improper use or abuse of the product, failure to follow the instructions contained in an Instruction Manual for the operation of the Power Train Component and parts. The cost of normal maintenance and replacement of service items which are not defective shall be paid for by the original purchaser.

C. Securing Warranty Service

Warranty service can be arranged for by contacting either a Tecumseh Authorized Service Outlet (any Tecumseh Registered Service Dealer, Tecumseh Authorized Service Distributor, or Tecumseh Central Warehouse Distributor) or by contacting Tecumseh, c/o Service Manager, Engine and Transmission Group Service Division, 900 North Street, Grafton, Wisconsin 53024. Warranty service can only be performed by a Tecumseh Authorized Service Outlet or by Tecumseh at its factory in Grafton, Wisconsin. At the time of requesting warranty service, evidence must be presented of the date of sale to the original purchaser. The purchaser shall pay any charges for making service calls and/or for transporting the product to and from the place where the inspection and/or warranty work is performed. The purchaser shall be responsible for any damage or loss incurred in connection with the transportation of Power Train Components and/or part(s) of the Power Train Components submitted for inspection and/or warranty work.

D. Limitation of Damages and Implied Warranties

The foregoing EXPRESSED WARRANTY IS IN LIEU OF ALL OTHER EXPRESS WARRANTIES. Neither Tecumseh nor any of its affiliates makes any warranties, representations or promises, written or oral, as to the quality of the Power Train Component or any of its parts, other than as set forth herein.

ANY IMPLIED WARRANTY OF MERCHANTABILITY OR FITNESS FOR A PARTICULAR PURPOSE, TO THE EXTENT THAT EITHER MAY APPLY TO ANY PART(S) OF POWER TRAIN COMPONENTS, SHALL BE LIMITED IN DURATION TO THE PERIODS OF THE EXPRESSED WARRANTIES DEFINED IN PARAGRAPH A HEREOF. IN NO EVENT WILL TECUMSEH BE LIABLE FOR ANY INCIDENTAL, CONSEQUENTIAL OR SPECIAL DAMAGES AND/OR EXPENSES. Some states do not allow limitations on how long an implied warranty lasts or the exclusion or limitation of incidental or consequential damages, so the above limitation(s) or exclusion(s) may not apply to you. This warranty gives you specific legal rights and you may also have other legal rights which vary from state to state.

E. No Dealer Warranty

Tecumseh neither assumes nor authorizes any other person, natural or corporate, to assume for Tecumseh any other obligations or liabilities in connection with or with respect to any part(s) of a Power Train Component. The seller or dealer of part(s) of a Power Train Component has no authority, whatsoever, to make any representations or promises on behalf of Tecumseh or to modify the terms or limitations of Tecumseh's warranty in any way.

LIMITED WARRANTY

The Manufacturer warrants to the original consumer purchaser that this product as manufactured is free from defects in materials and workmanship. For a period of one (1) year from date of purchase by the original consumer purchaser, we will repair or replace, at our option, without charge for parts or labor incurred in replacing parts, any part which we find to be defective due to materials or workmanship. This Warranty is subject to the following limitations and exclusions.

1. This warranty does not apply to the engine. Please contact your nearest dealer where they will send the machine to the engine manufacturer.
2. Transportation charges for the movement of any power equipment unit or attachment are the responsibility of the purchaser. Transportation charges for any parts submitted for replacement under this warranty must be paid by the purchaser unless such return is requested by your dealer.
3. Battery Warranty: On products equipped with a Battery, we will replace, without charge to you, any battery which we find to be defective in manufacture, during the first ninety (90) days of ownership. After ninety (90) days, we will exchange the Battery, charging you 1/12 of the price of a new Battery for each full month from the date of the original sale. Battery must be maintained in accordance with the instructions furnished.
4. The Warranty period for any products used for rental or commercial purposes is limited to 90 days from the date of original purchase.
5. This Warranty applies only to products which have been properly assembled, adjusted, operated, and maintained in accordance with the instructions furnished. This Warranty does not apply to any product which has been subjected to alteration, misuse, abuse, improper assembly or installation, delivery damage, or to normal wear of the product.
6. Exclusions: Excluded from this Warranty are belts, blades, blade adapters, normal wear, normal adjustments, standard hardware and normal maintenance.
7. In case of any problem within the boundaries of this warranty, contact the nearest department store, indicate the model number, serial number and the date of purchase of your machine. This warranty does not apply to accidental damages. All implicit warranties are limited to the same time frames. Or contact:

E.M. Services
54 Rue Lambrechts
92400 Courbevoie
France
Telephone: (1) 46678078
Fax: (1) 46678095

THIS WARRANTY DOES NOT APPLY TO INCIDENTAL OR CONSEQUENTIAL DAMAGES. ANY IMPLIED WARRANTIES ARE LIMITED TO THE SAME TIME PERIODS STATED HEREIN.



LAZER®