

MODEL HT182/242DX

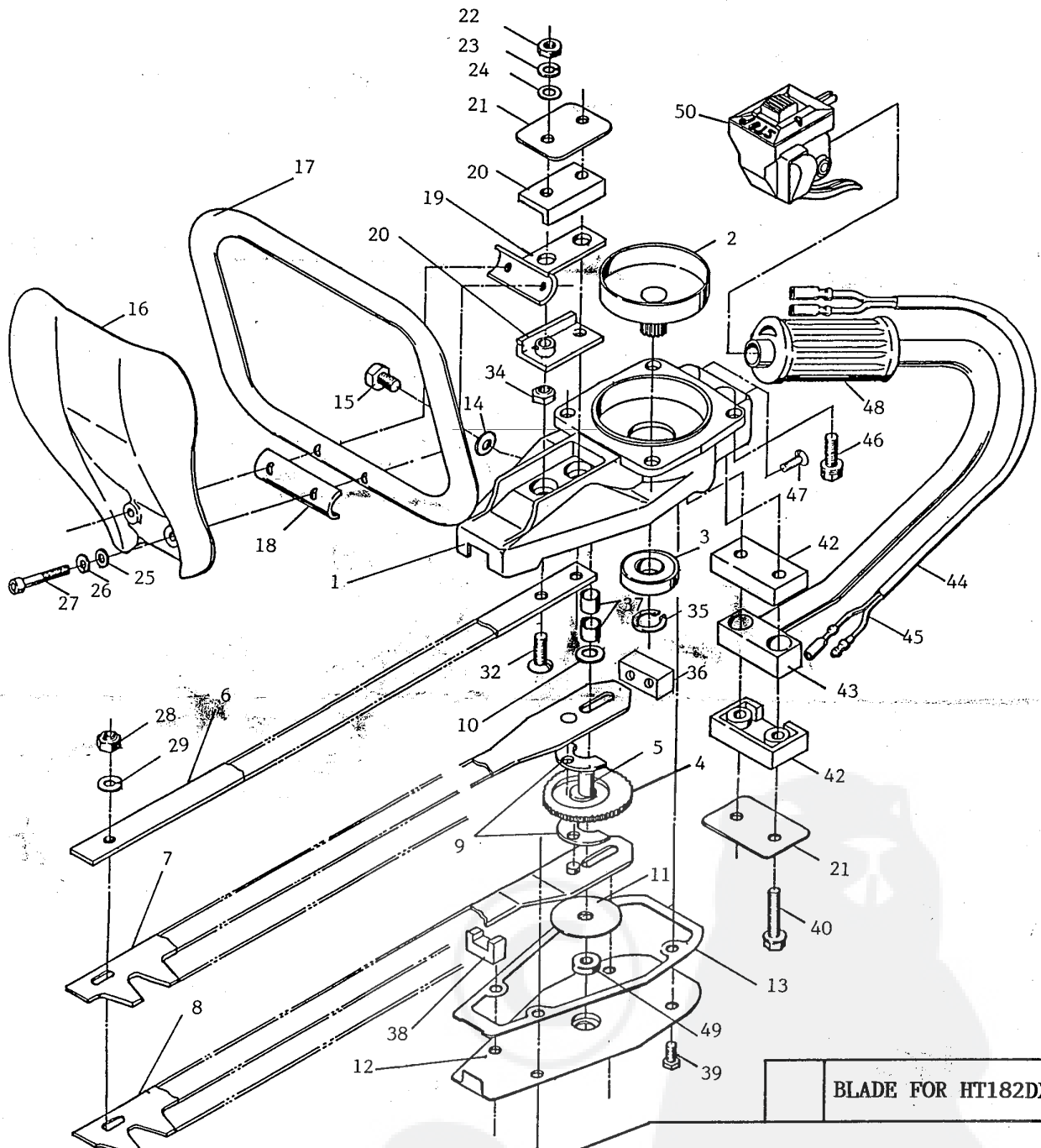

BLADE FOR HT182DX

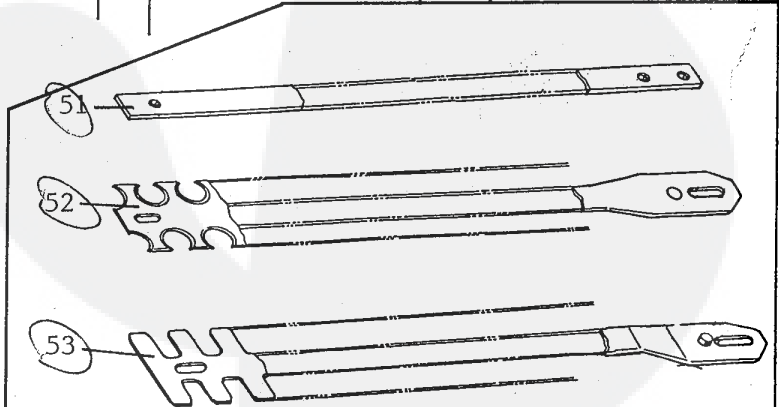

NO.	CODE NO.	NAME	QTY	MODEL	REMARKS
1	165-216-4	GEAR CASE (EG)	1	HT182/242DX	(EG)
2	502-904-0	CLUTCH DRUM	1	HT182/242DX	
3	004-602-0	BEARING #620ZZZ	1	HT182/242DX	#620ZZZ
4-A	502-911-1	CRANK GEAR ASS'Y(L)	1	HT182/242DX	INC #4-5
4	502-911-1	CRANK GEAR	1	HT182/242DX	
5	165-216-5	SHAFT-CRANKGEAR (L)	1	HT182/242DX	(EG)
6	502-929-0	STAY	1	HT242DX	
7	502-931-1	BLADE, UPPER	1	HT242DX	
8	502-933-1	BLADE, LOWER	1	HT242DX	
9	502-980-0	CAM-CRANKGEAR	2	HT182/242DX	
10	502-908-0	BLADE GUIDE (S)	1	HT182/242DX	
11	502-913-0	BLADE GUIDE (L)	1	HT182/242DX	
12	502-916-2	BOTTOM PLATE-GEAR CASE	1	HT182/242DX	W/BEARING
13	502-915-0	PACKING-BOTTOM PLATE	1	HT182/242DX	
14	003-619-0	PACKING-OIL HOLE	1	HT182/242DX	
15	001-050-0	OIL HOLE BOLT	1	HT182/242DX	
16	502-924-0	HANDLE COVER	1	HT182/242DX	
17	502-922-0	LOOP HANDLE	1	HT182/242DX	
18	502-923-0	HOLDER-LOOP HANDLE	1	HT182/242DX	
19	502-920-0	HANDLE STAY-LOOP HANDLE	1	HT182/242DX	
20	502-919-0	CUSHION (A),(B)-LOOP	1	HT182/242DX	A+B/SET
21	502-921-0	CUSHION PLATE	2	HT182/242DX	
22	003-002-0	HEX. NUT-STAY M6	2	HT182/242DX	M6
23	003-272-0	SPRING WASHER-STAY	2	HT182/242DX	
24	003-222-0	WASHER-STAY	2	HT182/242DX	
25	003-227-0	WASHER-L. HANDLE M5	2	HT182/242DX	M5
26	003-277-0	SPRING WASHER-L. HANDLE	2	HT182/242DX	
27	165-214-2	SOCKET H. SCREW M5X30	2	HT182/242DX	M5X30
28	003-122-1	U-NUT-BLADE	4	HT182DX	
29	003-272-0	SPRING WASHER-BLADE	4	HT182DX	
30	502-918-0	WASHER-BLADE	4	HT182DX	
31	502-917-0	BOLT (S)-BLADE	4	HT182DX	
28	003-122-1	U-NUT-BLADE	5	HT242DX	
29	003-272-0	SPRING WASHER-BLADE	5	HT242DX	
30	502-918-0	WASHER-BLADE	5	HT242DX	
31	502-917-0	BOLT (S)-BLADE	5	HT242DX	
32	002-129-0	FLAT H. BOLT-STAY 6X35	2	HT182/242DX	6X35
34	003-122-1	U-NUT-STAY M6	2	HT182/242DX	M6
35	008-061-0	STOP RING #S-15	1	HT182/242DX	#S-15
36	165-215-3	BEARING HOLDER	1	HT182/242DX	
37	502-907-2	CATCHER (L)-SHAFT	2	HT182/242DX	
38	502-914-0	GREASE PACKING	1	HT182/242DX	
39	002-906-0	TAP. SCREW-BOTTOM PLATE	4	HT182/242DX	
40	001-812-0	BOLT-U. HANDLE (M6X30)	2	HT182/242DX	M6X30
42	502-925-0	CUSHION (C)(D)-U-HANDLE	2	HT182/242DX	C+D/SET
43	502-927-0	U-HANDLE	1	HT182/242DX	
44	165-214-8	CABLE HOLDER (350MM)	1	HT182/242DX	L=350MM
45	502-928-0	CORD-TRIGGER LEVER	1	HT182/242DX	
46	001-806-0	BOLT-ENGINE (M6X20)	4	HT182/242DX	M6X20
47	002-103-0	FLAT H. SCREW 4X10	2	HT182/242DX	4X10
48	210-116-1	GRIP-HANDLE	1	HT182/242DX	
49	004-516-0	BEARING #606	1	HT182/242DX	#606
50	010-260-0	TRIGGER LEVER 16MM	1	HT182/242DX	
51	502-906-0	STAY	1	HT182DX	
52	502-909-1	BLADE, UPPER	1	HT182DX	
53	502-912-1	BLADE, LOWER	1	HT182DX	
A	165-212-7	LOCK-BAND	1	HT182/242DX	
B	165-214-9	SPANNER 8X10	1	HT182/242DX	
C	165-221-1	BLADE COVER	1	HT242DX	
D	165-215-0	HEX. WRENCH	1	HT182/242DX	
E	165-215-1	BLADE COVER	2	HT182DX	
F	165-225-4	FLANGE (FOR KAWASAKI)	1	HT182DX	TG18LDX
G	165-102-3	SOCKET H. SCREW M6X16	3	HT182DX	M6X16
H	001-304-1	HEX. WRENCH	1	HT182DX	

MODEL HT. 182/242DX

BODY PARTS LIST