

T2 SERVICE SCHEMATIC

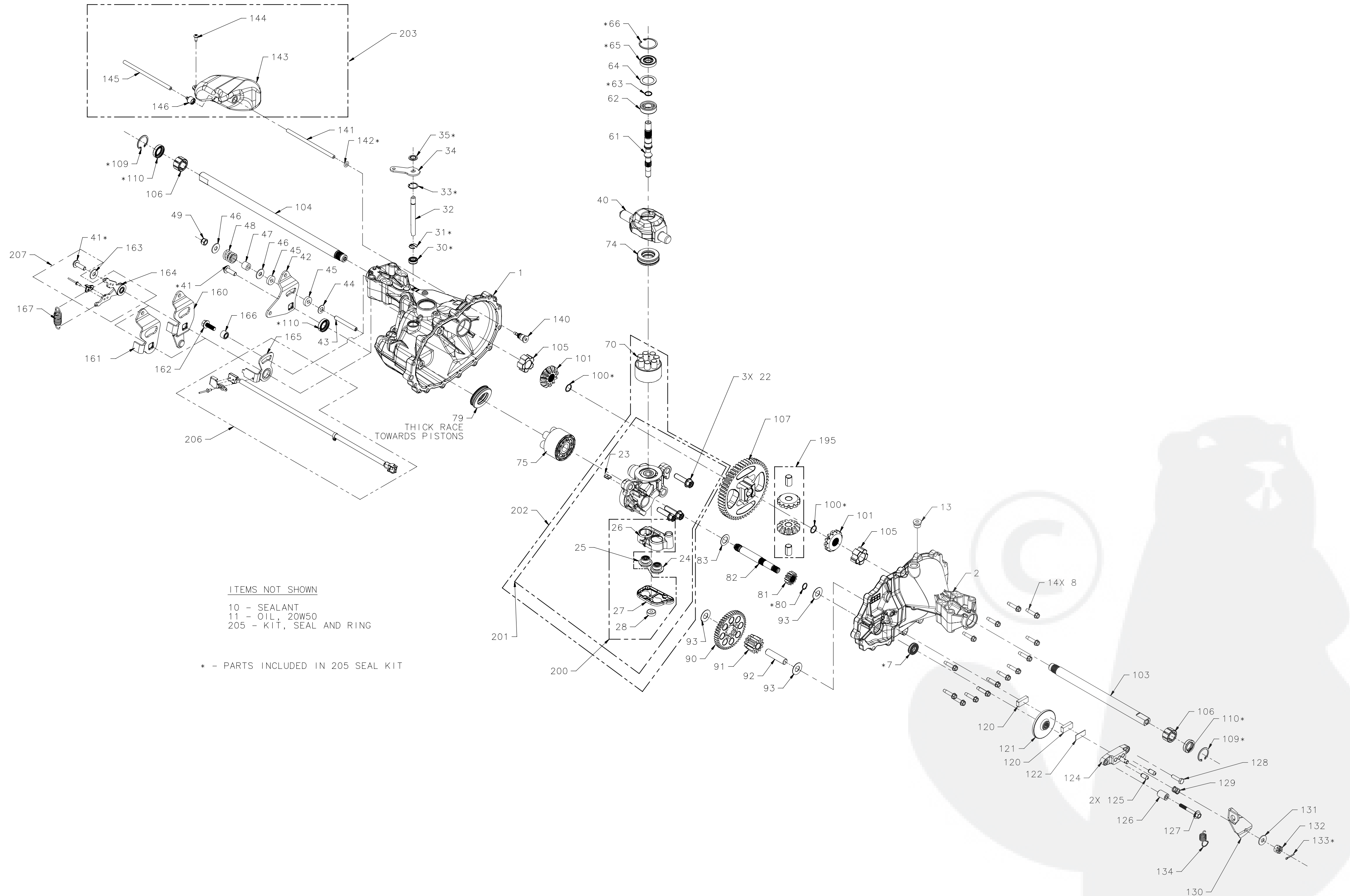

ITEMS NOT SHOWN
 10 - SEALANT
 11 - OIL, 20W50
 205 - KIT, SEAL AND RING

* - PARTS INCLUDED IN 205 SEAL KIT



CONTROL TYPE				
Char 9	ITEM	COMPONENT	DESCRIPTION	QTY
1	43	52304	SCREW, SET 5/16-24 X 2.50	1
	44	52643	WASHER, BELLEVILLE	1
	45	52298	WASHER, PLASTIC, .32X.80X.21	2
	46	44130	WASHER .34X.88X.06	2
	47	50278	SPACER .32X.59X.50	1
	48	50277	SPRING, HELICAL COMP	1
	49	50317	NUT, HEX 5/16-24 NYLON INSERT	1
2	162	51064	BOLT, HEX FLANGE HEAD	1
	163	44130	WASHER .34X.88X.06	1
	166	52481	BUSHING	1
	167	52401	SPRING, EXTENSION	1
	206	71677	KIT, T2 ROS	1
207	71712	KIT, T2 ROS	1	

Char 9	ITEM	COMPONENT	DESCRIPTION	QTY
3	162	51064	BOLT, HEX FLANGE HEAD	1
	163	44130	WASHER .34X.88X.06	1
	164	52611	ASSEMBLY, RTN BI-DIRECTIONAL	1
	165	52618	ARM, NEUTRAL ASSEMBLY	1
	166	52481	BUSHING	1
	167	52401	SPRING, EXTENSION	1
4	162	51064	BOLT, HEX FLANGE HEAD	1
	163	44130	WASHER .34X.88X.06	1
	164	52611	ASSEMBLY, RTN BI-DIRECTIONAL	1
	165	53673	ARM, NEUTRAL ASSEMBLY	1
	166	52481	BUSHING	1
167	51605	SPRING, EXTENSION RTN-44LBS	1	
5	43	52304	SCREW, SET 5/16-24 X 2.50	1
	44	52643	WASHER, BELLEVILLE	1
	45	52298	WASHER, PLASTIC, .32 X .80 X .21	2
	46	44130	WASHER .34 X .88 X .06	2
	47	50278	SPACER .32 X .59 X .50	1
	48	50277	SPRING, HELICAL COMP	1
	49	50317	NUT, HEX 5/16-24 NYLON INSERT	1
	50	52481	BUSHING	1

T2 SERVICE SCHEMATIC

MODEL NUMBER:

T	2
---	---

 -

--	--	--	--

 -

	*	*
--	---	---

 -

--	--	--	--

CHARACTER #:

1	2
---	---

 -

3	4	5	6
---	---	---	---

 -

7	8	9	10
---	---	---	----

 -

11	12	13	14
----	----	----	----

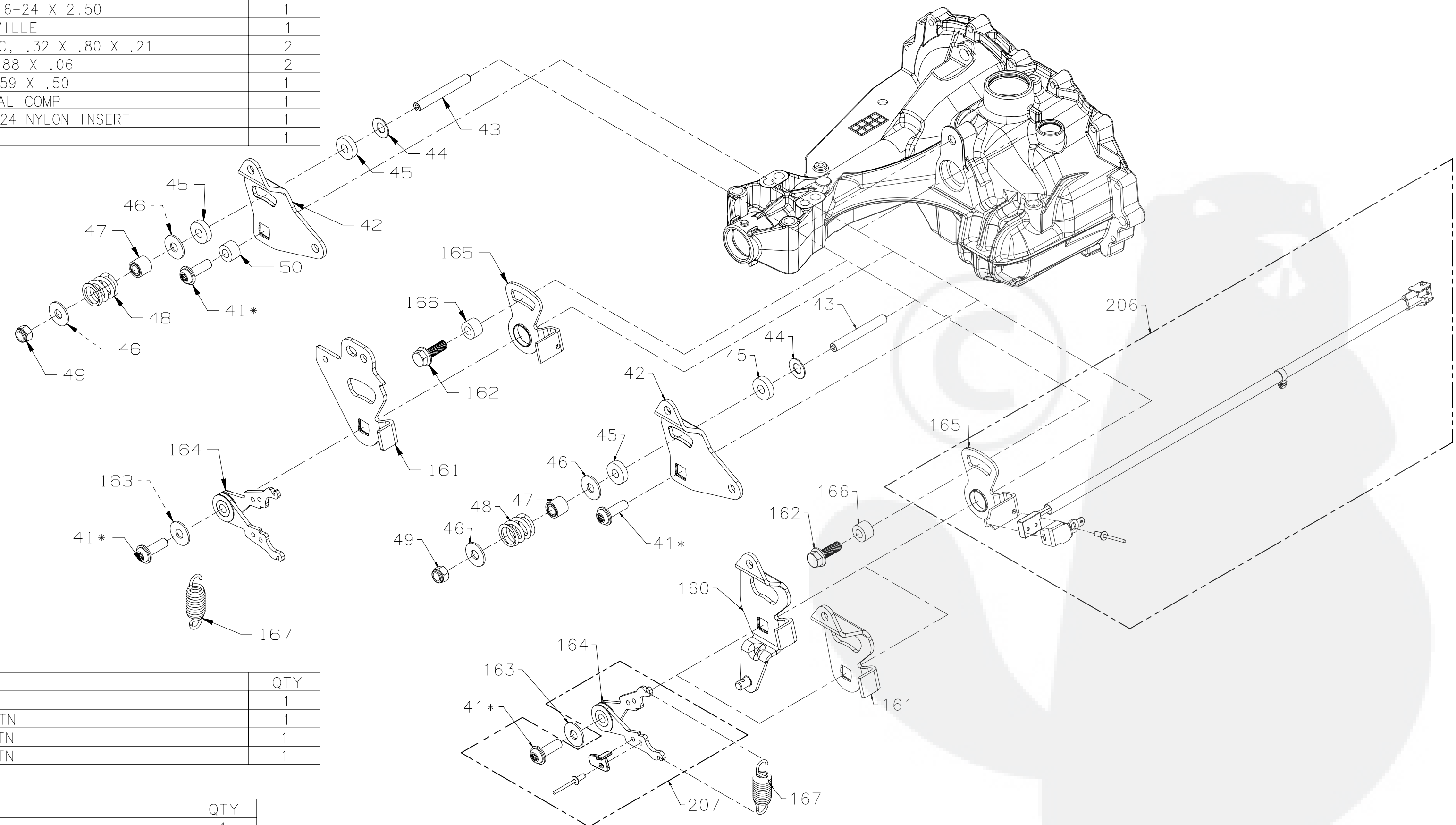

CONTROL ARM				
Char10	ITEM	COMPONENT	DESCRIPTION	QTY
A	42	52652	ARM, CNTRL	1
B	160	52823	ARM, CNTRL, RTN	1
C	161	52478	ARM, CNTRL, RTN	1
D	161	53662	ARM, CNTRL, RTN	1

COMMON PARTS			
ITEM	COMPONENT	DESCRIPTION	QTY
41	51812	SCREW, 5/16-18 X 1	1
205	71554	KIT, SEAL	1



* - PARTS INCLUDED IN 205 SEAL KIT

T2 SERVICE SCHEMATIC

MODEL NUMBER:

T	2	-			*	*	-									
1	2	-	3	4	5	6	-	7	8	9	10	-	11	12	13	14

CHECK VALVES				
Char 5	ITEM	COMPONENT	DESCRIPTION	QTY
B	24	51084	ASSEMBLY, CHECK PLUG W/ WASHER, .027	1
	25	51084	ASSEMBLY, CHECK PLUG W/ WASHER, .027, SPRING	1
C	24	51485	ASSEMBLY, CHECK PLUG W/ WASHER, .027, SPRING	1
	25	51485	ASSEMBLY, CHECK PLUG W/ WASHER, .027, SPRING	1
D	24	52006	ASSEMBLY, CHECK PLUG W/ WASHER, .044	1
	25	52006	ASSEMBLY, CHECK PLUG W/ WASHER, .044	1
E	24	51084	ASSEMBLY, CHECK PLUG W/ WASHER, .027	1
	25	52006	ASSEMBLY, CHECK PLUG W/ WASHER, .044	1
F	24	52006	ASSEMBLY, CHECK PLUG W/ WASHER, .044	1
	25	51084	ASSEMBLY, CHECK PLUG W/ WASHER, .027	1

CENTER SECTION					
IF CHAR 5	AND CHAR 6	THEN ITEM	COMPONENT	DESCRIPTION	QTY
B	C (5 PISTON PUMP)	70		MUST ORDER 71550	
		200	71553	KIT, FILTER	1
		202	71550	CENTER SECTION WITH FILTER AND 7P8CC PISTON BLOCK ASSEMBY	1
		70	72228	KIT, BLOCK, 7 PISTON, 8cc	1
		201	72190	CENTER SECTION WITH FILTER	1
C	E (7 PISTON PUMP)	70		MUST ORDER 71886	
		200	71553	KIT, FILTER	1
		202	71886	CENTER SECTION WITH FILTER AND 7P8CC PISTON BLOCK ASSEMBY	1
		70	72228	KIT, BLOCK, 7 PISTON, 8cc	1
		201	72191	CENTER SECTION WITH FILTER	1
D	C (5 PISTON PUMP)	70		MUST ORDER 72060	
		200	71553	KIT, FILTER	1
		202	72060	CENTER SECTION WITH FILTER AND 7P8CC PISTON BLOCK ASSEMBY	1
		70	72228	KIT, BLOCK, 7 PISTON, 8cc	1
		201	72192	CENTER SECTION WITH FILTER	1
E	E (7 PISTON PUMP)	70		MUST ORDER 72061	
		200	71553	KIT, FILTER	1
		202	72061	CENTER SECTION WITH FILTER AND 7P8CC PISTON BLOCK ASSEMBY	1
		70	72228	KIT, BLOCK, 7 PISTON, 8cc	1
		201	72193	CENTER SECTION WITH FILTER	1
F	C (5 PISTON PUMP)	70		MUST ORDER 72062	
		200	71553	KIT, FILTER	1
		202	72062	CENTER SECTION WITH FILTER AND 7P8CC PISTON BLOCK ASSEMBY	1
		70	72228	KIT, BLOCK, 7 PISTON, 8cc	1
		201	72194	CENTER SECTION WITH FILTER	1
B	D (5 PISTON PUMP)	70		MUST ORDER 71966	
		200	71553	KIT, FILTER	1
		202	71966	CENTER SECTION WITH FILTER AND 7P8CC PISTON BLOCK ASSEMBY	1
		70	72228	KIT, BLOCK, 7 PISTON, 8cc	1
		201	72195	CENTER SECTION WITH FILTER	1
C	F (7 PISTON PUMP)	70		MUST ORDER 71967	
		200	71553	KIT, FILTER	1
		202	71967	CENTER SECTION WITH FILTER AND 7P8CC PISTON BLOCK ASSEMBY	1
		70	72228	KIT, BLOCK, 7 PISTON, 8cc	1
		201	72196	CENTER SECTION WITH FILTER	1
D	D (5 PISTON PUMP)	70		MUST ORDER 72063	
		200	71553	KIT, FILTER	1
		202	72063	CENTER SECTION WITH FILTER AND 7P8CC PISTON BLOCK ASSEMBY	1
		70	72228	KIT, BLOCK, 7 PISTON, 8cc	1
		201	72197	CENTER SECTION WITH FILTER	1
E	F (7 PISTON PUMP)	70		MUST ORDER 72064	
		200	71553	KIT, FILTER	1
		202	72064	CENTER SECTION WITH FILTER AND 7P8CC PISTON BLOCK ASSEMBY	1
		70	72228	KIT, BLOCK, 7 PISTON, 8cc	1
		201	72198	CENTER SECTION WITH FILTER	1
F	D (5 PISTON PUMP)	70		MUST ORDER 72065	
		200	71553	KIT, FILTER	1
		202	72065	CENTER SECTION WITH FILTER AND 7P8CC PISTON BLOCK ASSEMBY	1
		70	72228	KIT, BLOCK, 7 PISTON, 8cc	1
		201	72199	CENTER SECTION WITH FILTER	1
H	E (7 PISTON PUMP)	70	72228	KIT, BLOCK, 7 PISTON, 8cc	1
		200	71553	KIT, FILTER	1
		201	72235	CENTER SECTION WITH FILTER	1

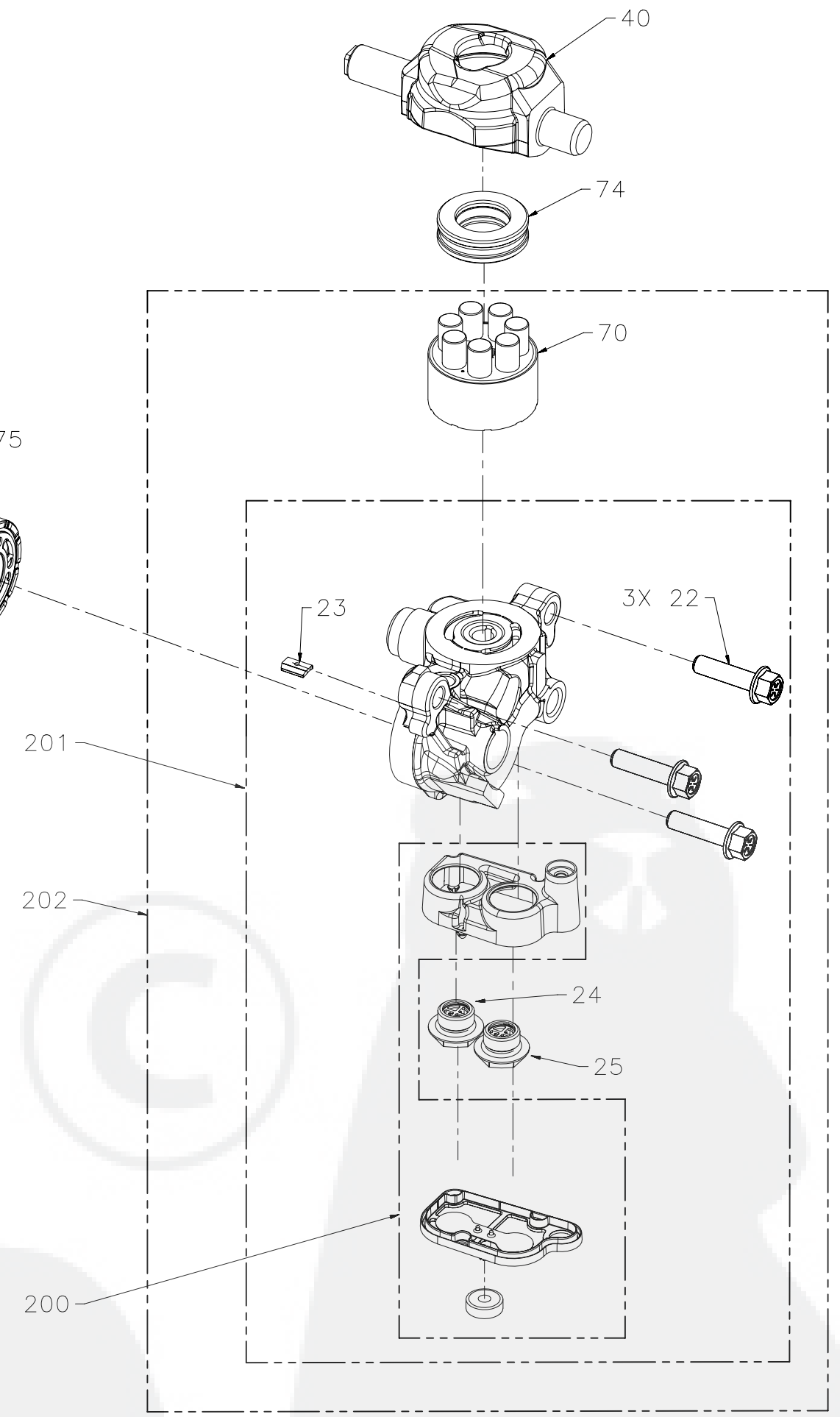
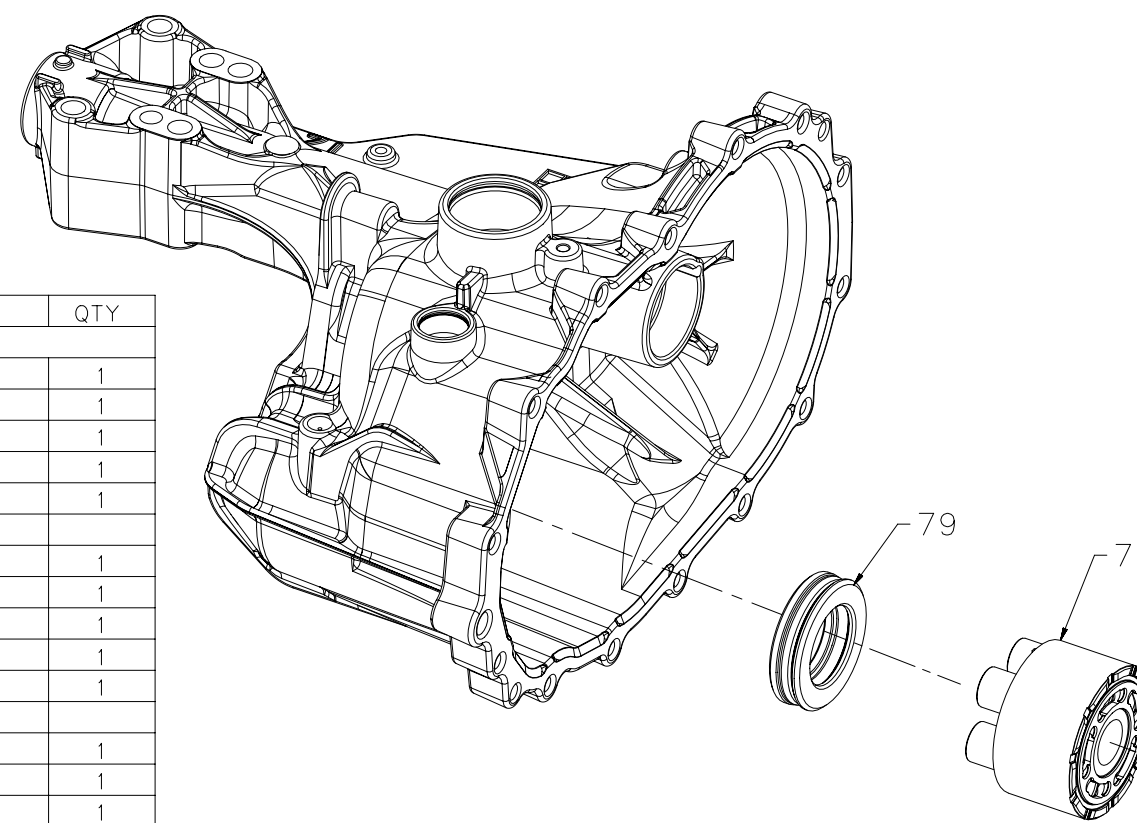

COMMON PARTS				
ITEM	COMPONENT	DESCRIPTION	QTY	
22	52137	BOLT, HEX FLANGE, 3/8-16, C/S	3	
23	52502	PLATE, BYPASS	1	
70		SEE CENTER SECTION MATRIX BELOW		
75	70331	ASSEMBLY, PISTON BLOCK, 5P10CC	1	
40	52450	TRUNNION, SWASH PLATE	1	
74	52465	BRG, THRUST BALL 27X47X14	1	
79	50551	BRG, THRUST BALL 30X52X13	1	



T2 SERVICE SCHEMATIC

MODEL NUMBER: T 2 - * - - - -
 CHARACTER #: 1 2 - 3 4 5 6 - 7 8 9 10 - 11 12 13 14

GEAR RATIO

Char 3	ITEM	COMPONENT	DESCRIPTION	QTY
A	081	52466	GEAR, 13T PINION	1
	090	52469	GEAR, 11T/48T	1
	091	52470	GEAR, JACKSHAFT 11T	1
B	081	52484	GEAR, 14T PINION	1
	090	52483	GEAR, 11T/47T	1
	091	52470	GEAR, JACKSHAFT 11T	1
C	081	52466	GEAR, 13T PINION	1
	090	53372	GEAR, 10T/48T	1
	091	53371	GEAR, JACKSHAFT 10T	1

COMMON PARTS

ITEM	COMPONENT	DESCRIPTION	QTY
080	44354	RING, RET .50 EXT	1
082	52467	SHAFT, MOTOR	1
083	52468	WASHER .60X1.00X.03	1
092	52471	JACK SHAFT (PIN)	1
093	50132	WASHER .5X1.0X.03	3
205	71554	KIT, SEAL	1

* - PARTS INCLUDED IN 205 SEAL KIT

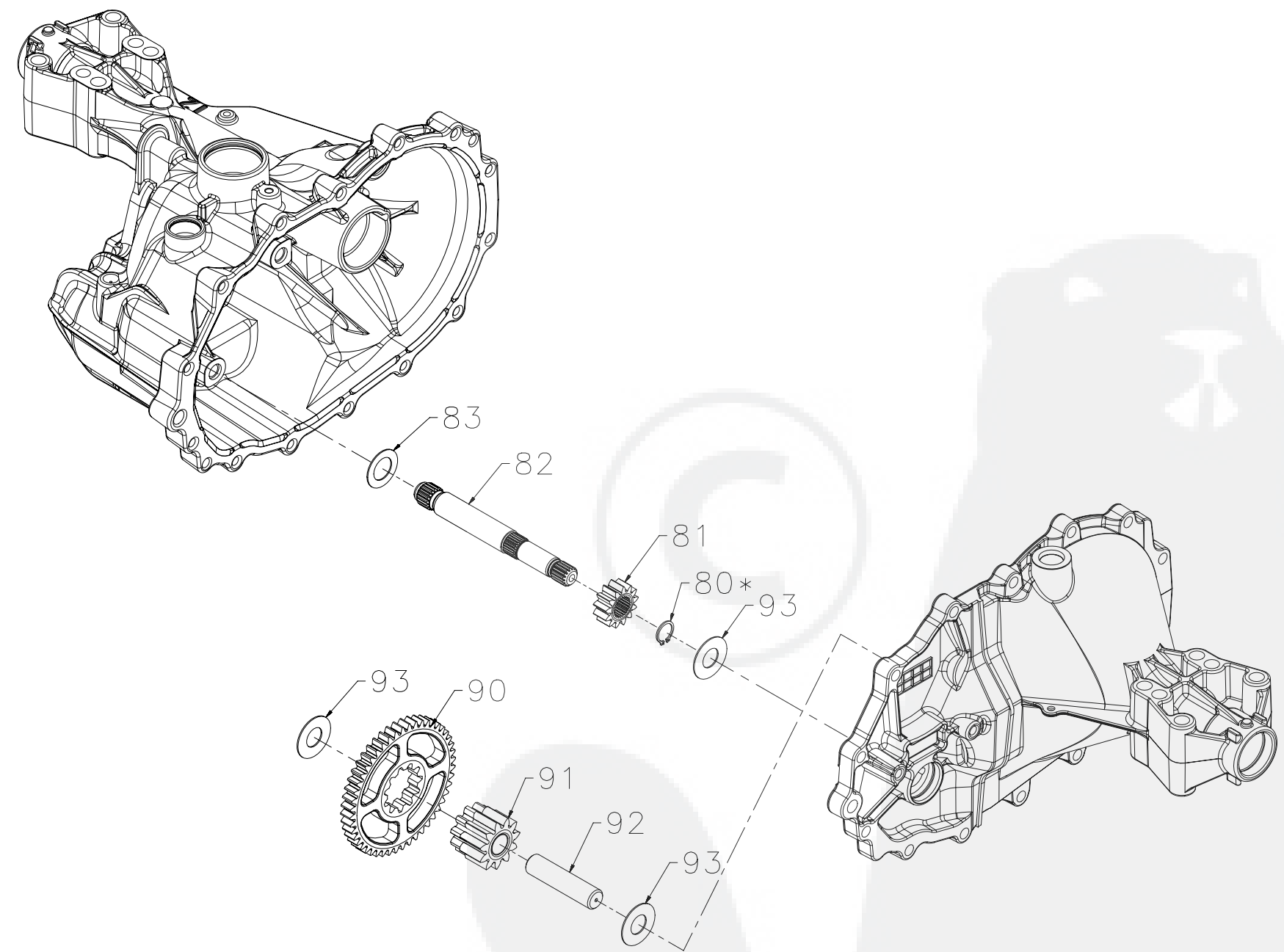

T2 SERVICE SCHEMATIC

MODEL NUMBER:

T	2
1	2

 -

*			
3	4	5	6

 -

7	8	9	10

 -

11	12	13	14

CHARACTER #:

1	2		
3	4	5	6

 -

7	8	9	10
11	12	13	14

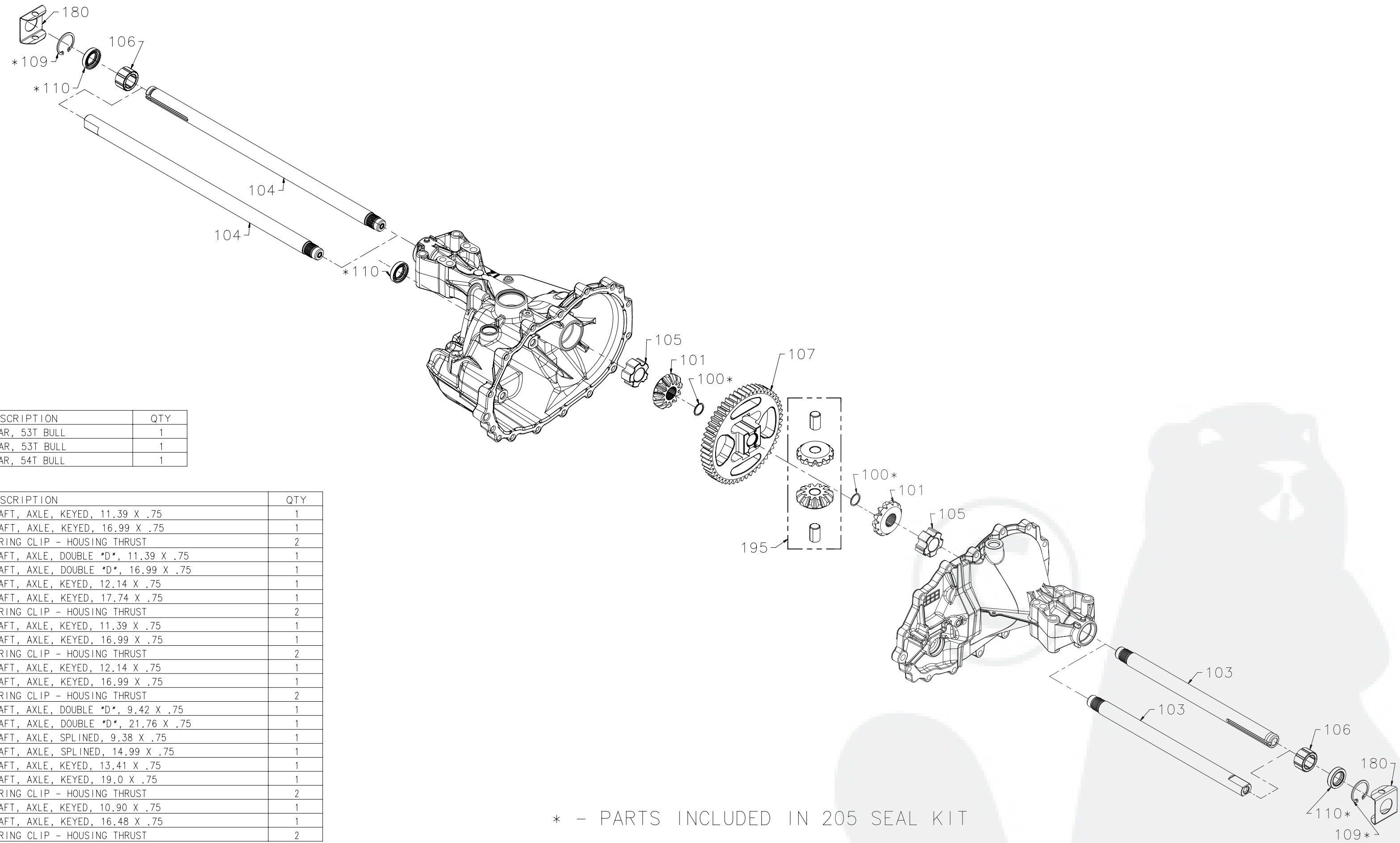

* - PARTS INCLUDED IN 205 SEAL KIT

GEAR RATIO

Char 3	ITEM	COMPONENT	DESCRIPTION	QTY
A	107	52472	GEAR, 53T BULL	1
B	107	52472	GEAR, 53T BULL	1
C	107	53370	GEAR, 54T BULL	1

SHAFT TYPE AND LENGTH

Char 4	ITEM	COMPONENT	DESCRIPTION	QTY
A	103	51068	SHAFT, AXLE, KEYED, 11.39 X .75	1
	104	51067	SHAFT, AXLE, KEYED, 16.99 X .75	1
	180	53319	SPRING CLIP - HOUSING THRUST	2
B	103	51079	SHAFT, AXLE, DOUBLE *D*, 11.39 X .75	1
	104	51078	SHAFT, AXLE, DOUBLE *D*, 16.99 X .75	1
C	103	51354	SHAFT, AXLE, KEYED, 12.14 X .75	1
	104	51353	SHAFT, AXLE, KEYED, 17.74 X .75	1
	180	53319	SPRING CLIP - HOUSING THRUST	2
D	103	53507	SHAFT, AXLE, KEYED, 11.39 X .75	1
	104	53506	SHAFT, AXLE, KEYED, 16.99 X .75	1
	180	53319	SPRING CLIP - HOUSING THRUST	2
E	103	51354	SHAFT, AXLE, KEYED, 12.14 X .75	1
	104	51067	SHAFT, AXLE, KEYED, 16.99 X .75	1
	180	53319	SPRING CLIP - HOUSING THRUST	2
F	103	53636	SHAFT, AXLE, DOUBLE *D*, 9.42 X .75	1
	104	51105	SHAFT, AXLE, DOUBLE *D*, 21.76 X .75	1
G	103	53486	SHAFT, AXLE, SPLINED, 9.38 X .75	1
	104	53485	SHAFT, AXLE, SPLINED, 14.99 X .75	1
H	103	53441	SHAFT, AXLE, KEYED, 13.41 X .75	1
	104	53442	SHAFT, AXLE, KEYED, 19.0 X .75	1
	180	53319	SPRING CLIP - HOUSING THRUST	2
J	103	54246	SHAFT, AXLE, KEYED, 10.90 X .75	1
	104	54245	SHAFT, AXLE, KEYED, 16.48 X .75	1
	180	53319	SPRING CLIP - HOUSING THRUST	2

COMMON PARTS

ITEM	COMPONENT	DESCRIPTION	QTY
100	44871	RING, RET - SPIRAL .625 EXT	2
101	51769	GEAR, BEVEL 12T SPLINE ID	2
105	52280	BUSHING, INBOARD	2
106	52278	BUSHING, OUTBOARD	2
109	52275	RING, RET, INT AXLE	2
110	53901	SEAL, LIP .75 X 1.125 X .25	3
195	72314	KIT, MITER GEARS & PINS	1
205	71554	KIT, SEAL	1



T2 SERVICE SCHEMATIC

MODEL NUMBER:

T	2
---	---

 -

--	--	--	--

 -

*			
---	--	--	--

 -

*			
---	--	--	--

CHARACTER #:

1	2
---	---

 -

3	4	5	6
---	---	---	---

 -

7	8	9	10
---	---	---	----

 -

11	12	13	14
----	----	----	----

BYPASS ARM				
Char 11	ITEM	COMPONENT	DESCRIPTION	QTY
1	34	52460	ARM, BYPASS	1

BRAKE ARM				
Char 7	ITEM	COMPONENT	DESCRIPTION	QTY
X		NONE		
1	130	23710	ARM, BRAKE	1
	134	51529	SPRING, BRAKE ARM BIAS	1
2	130	52374	ARM, BRAKE	1
	134	51529	SPRING, BRAKE ARM BIAS	1
3	130	44094	ARM, BRAKE	1
	134	50884	SPRING, BRAKE ARM BIAS	1
4	130	51142	ARM, BRAKE	1
	134	51607	SPRING, BRAKE ARM BIAS	1
5	130	53654	ARM, BRAKE	1
	134	50884	SPRING, BRAKE ARM BIAS	1
AND 1,2, 3,4, 5	120	44132	PUCK, BRAKE	2
	121	52473	ROTOR, BRAKE	1
	122	44134	PLATE, PUCK	1
	124	62589	YOKE, BRAKE	1
	125	44127	PIN, BRK .31X.73 PLATED	2
	126	23711	SPACER .26X.57X.87	1
	127	51146	SCREW 1/4-20 X 2.0 W/PATCH	1
	128	44433	SCREW 1/4-20 X 1 (PATCH)	1
	129	50919	SPRING, COMP BRAKE ANT1-DRAG	1
	131	44130	WASHER .34X.88X.06	1
	132	44142	NUT, CASTLE 5/16-24 PL	1
	133	44101	PIN, COTTER 3/32X3/4	1

COMMON PARTS

ITEM	COMPONENT	DESCRIPTION	QTY
30	51626	SEAL, LIP .375X.75X.25 TC	1
31	51628	RING, RET .375 EXT	1
32	52459	ROD, ACTUATOR BYPASS	1
33	51627	RING, RET .750 INT	1
35	51630	RING, RET .375 EXT	1
61	52462	SHAFT, INPUT	1
62	2003043	BALL BEARING 15X35X11	1
63	2003016	RING, RET WIRE .512 ID	1
64	2003018	WASHER 1.23X1.56X.04	1
65	9008000-0128	SEAL, LIP 15X35X7	1
66	2003052	RING, RET 1.56 INT	1
205	71554	KIT, SEAL	1

* - PARTS INCLUDED IN 205 SEAL KIT

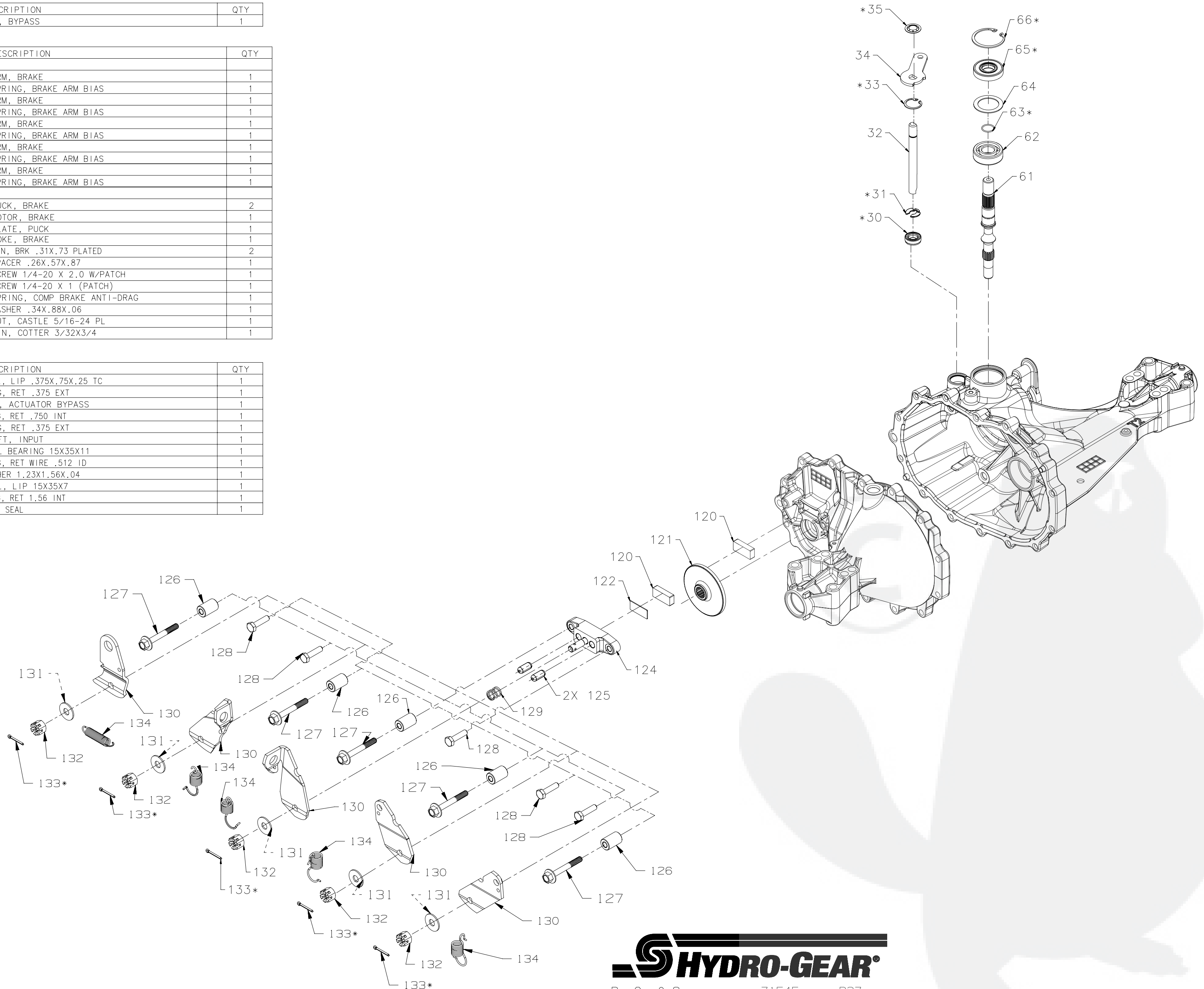

T2 SERVICE SCHEMATIC

MODEL NUMBER:

T	2
---	---

 -

3	4	5	6
---	---	---	---

 -

7	8	9	10
---	---	---	----

 -

11	*	13	14
----	---	----	----

CHARACTER #:

1	2
---	---

 -

3	4	5	6
---	---	---	---

 -

7	8	9	10
---	---	---	----

 -

11	*	13	14
----	---	----	----

FAN & PULLEY KIT				
Char12	ITEM	COMPONENT	DESCRIPTION	QTY
X		None		
A	150	51230	FAN, 7", 10 BLADE	1
	151	51231	PULLEY ASSEMBLY, 3.86"	1
	152	51244	NUT, HEX LOCK, 1/2-20 (NYLON INSERT)	1
	153	51523	WASHER, OD SLOTTED .53 X 1.63 X .06	1
C	150	51365	FAN, 6", 10 BLADE	1
	151	51721	PULLEY ASSEMBLY, 4.4"	1
	152	51244	NUT, HEX LOCK, 1/2-20 (NYLON INSERT)	1
	153	50752	SCREW, 1/4-20 X 0.75	3
E	204	72137	KIT, FAN & PULLEY	1
G	150	51579	FAN, 6", 10 BLADE	1
	151	52871	PULLEY ASSEMBLY, 4.50"	1
	152	51244	NUT, HEX LOCK, 1/2-20 (NYLON INSERT)	1
	153	50752	SCREW, 1/4-20 X 0.75	3
J	204	72136	KIT, FAN & PULLEY	1
K	150	51365	FAN, 6", 10 BLADE	1
	151	52039	PULLEY ASSEMBLY, 4"	1
	152	51244	NUT, HEX LOCK, 1/2-20 (NYLON INSERT)	1
	153	50752	SCREW, 1/4-20 X 0.75	3
L	204	72135	KIT, FAN & PULLEY	1
M	150	51579	FAN, 6", 10 BLADE	1
	151	52141	PULLEY, 4"	1
	152	51244	NUT, HEX LOCK, 1/2-20 (NYLON INSERT)	1
	153	51076	SCREW, 1/4-20 X 0.875	3
N	150	52315	FAN, 7", 10 BLADE	1
	151	51721	PULLEY, 4.4"	1
	152	51244	NUT, HEX LOCK, 1/2-20 (NYLON INSERT)	1
	153	51076	SCREW, 1/4-20 X 0.875	3
P	204	72134	KIT, FAN & PULLEY	1
R	150	53822	FAN, 7", 10 BLADE	1
	151	53804	PULLEY, 4.5"	1
	152	44133	NUT, HEX JAM, 1/2-20 W/PATCH	1
	153	53812	HUB, PULLEY	1
T	150	53810	FAN, 7", 10 BLADE	1
	151	53815	PULLEY, 4.0"	1
	152	44133	NUT, HEX JAM, 1/2-20 W/PATCH	1
	153	51523	WASHER, OD SLOTTED .53 X 1.63 X .06	1
U	154	53812	HUB, PULLEY	1
	150	53811	FAN, 6", 10 BLADE	1
	151	53815	PULLEY, 4.0"	1
	152	44133	NUT, HEX JAM, 1/2-20 W/PATCH	1
2	153	51523	WASHER, OD SLOTTED .53 X 1.63 X .06	1
	154	53812	HUB, PULLEY	1
	150	53808	FAN, 6", 10 BLADE	1
	151	53806	DISC, PULLEY, 4.5"	1
3	152	44133	NUT, HEX JAM, 1/2-20 W/PATCH	1
	153	51523	WASHER, OD SLOTTED .53 X 1.63 X .06	1
	154	53812	HUB, PULLEY 1.56	1
	150	53810	FAN, 7", 10 BLADE	1
5	151	53609	PULLEY, 5.0"	1
	152	44133	NUT, HEX JAM, 1/2-20 W/PATCH	1
	153	51523	WASHER, OD SLOTTED .53 X 1.63 X .06	1
	154	53812	HUB, PULLEY	1
6	150	53808	FAN, 7", 10 BLADE	1
	151	53805	PULLEY, 4.0"	1
	152	44133	NUT, HEX JAM, 1/2-20 W/PATCH	1
	153	51523	WASHER, OD SLOTTED .53 X 1.63 X .06	1
154	53812	HUB, PULLEY	1	

7	150	53810	FAN, 7", 10 BLADE	1
	151	53804	PULLEY, 4.5"	1
	152	44133	NUT, HEX JAM, 1/2-20 W/PATCH	1
	153	51523	WASHER, OD SLOTTED .53 X 1.63 X .06	1
8	154	53812	HUB, PULLEY	1
	150	53822	FAN, 7", 10 BLADE	1
	151	53815	PULLEY, 4.0"	1
	152	44133	NUT, HEX JAM, 1/2-20 W/PATCH	1
9	153	54024	FLANGE, PULLEY, 4.895	1
	154	53812	HUB, PULLEY	1
	150	53824	FAN, 7", 10 BLADE	1
	151	53806	PULLEY, 4.5"	1
	152	44133	NUT, HEX JAM, 1/2-20 W/PATCH	1
	153	53812	HUB, PULLEY	1

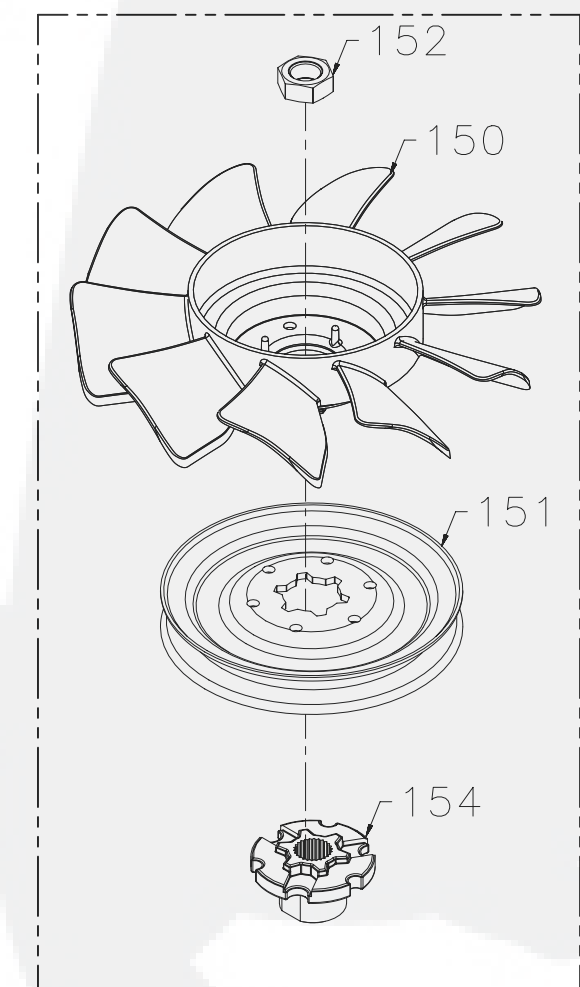
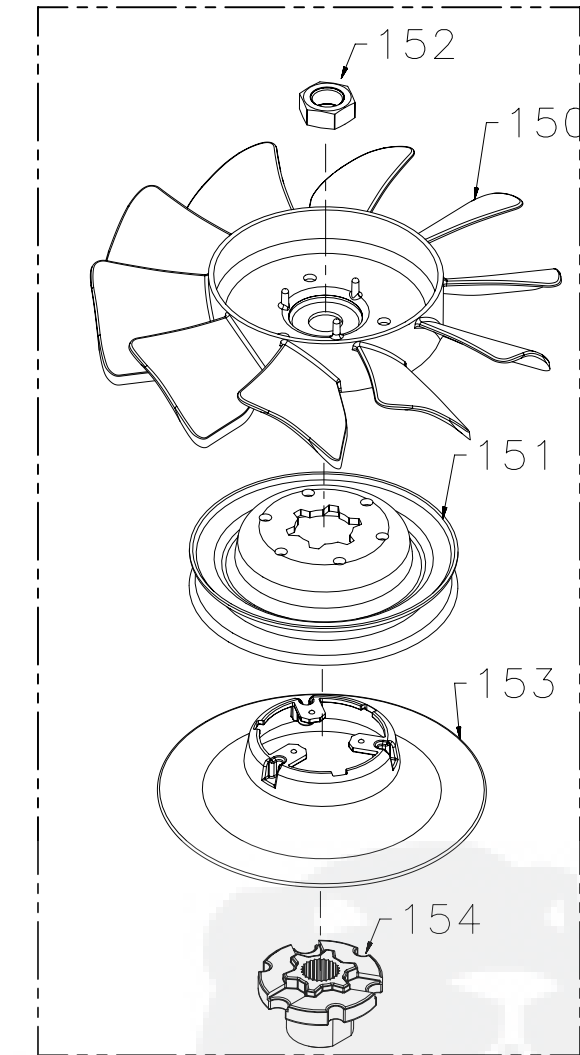
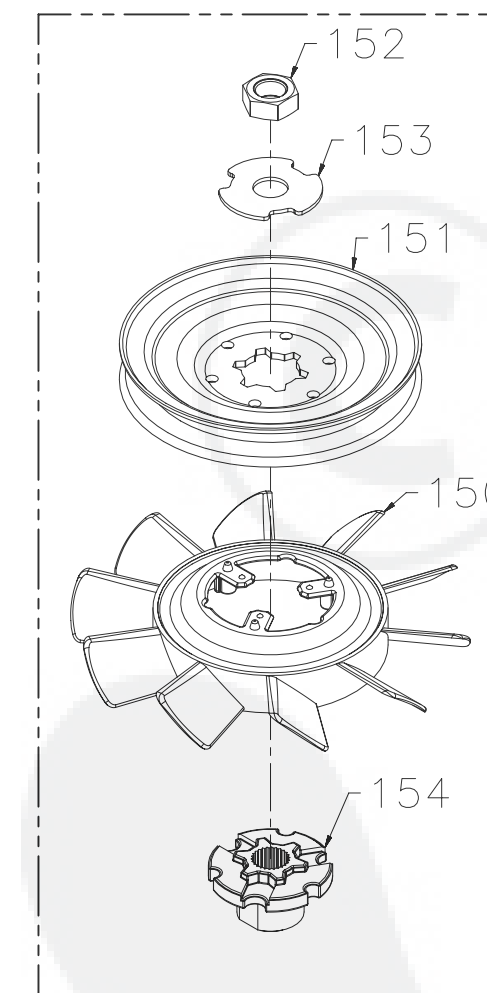
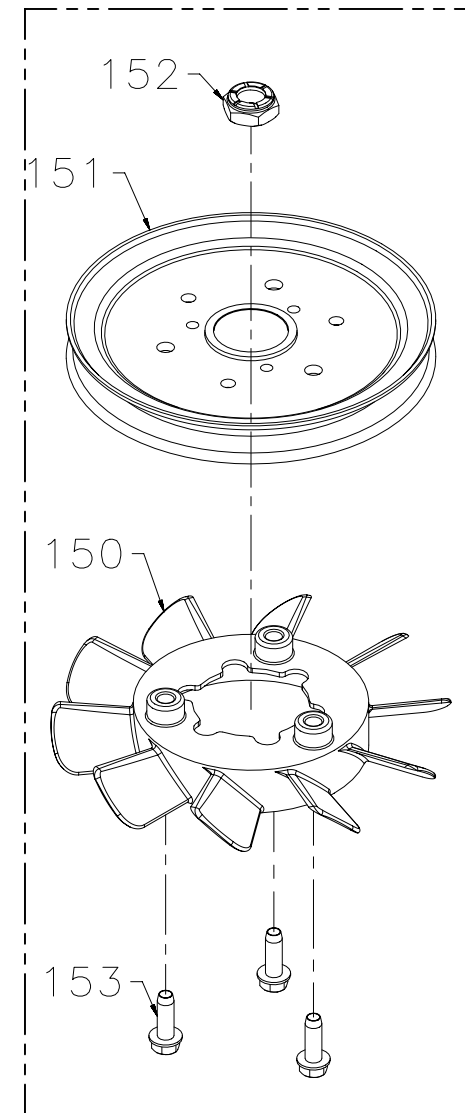
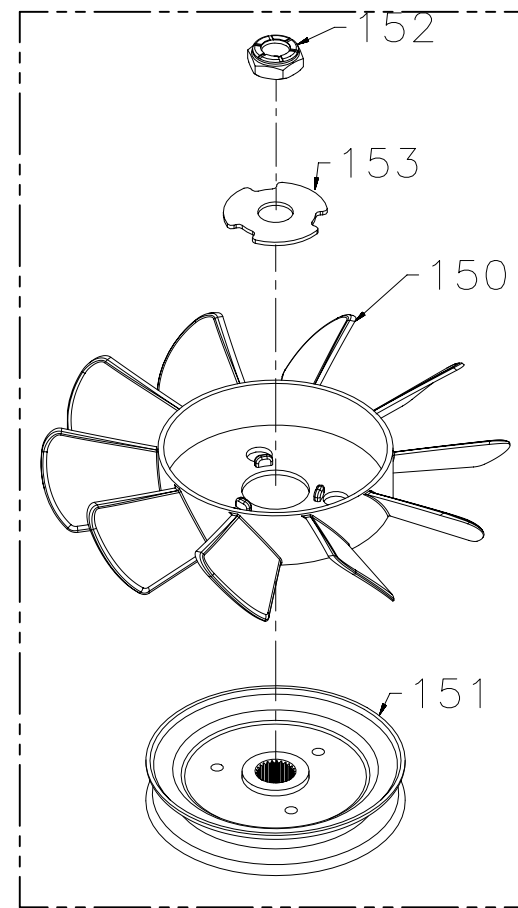

ITEM #204

Char12	ITEM	COMPONENT	DESCRIPTION	QTY
A		70460	KIT, FAN & PULLEY	1
C		70810	KIT, FAN & PULLEY	1
E		72137	KIT, FAN & PULLEY	1
G		71602	KIT, FAN & PULLEY	1
H		71675	KIT, FAN & PULLEY	1
J		72136	KIT, FAN & PULLEY	1
K		71140	KIT, FAN & PULLEY	1
L		72135	KIT, FAN & PULLEY	1
M		71227	KIT, FAN & PULLEY	1
N		72037	KIT, FAN & PULLEY	1
P	204	72134	KIT, FAN & PULLEY	1
R		72131	KIT, FAN & PULLEY	1
T		72133	KIT, FAN & PULLEY	1
U		72136	KIT, FAN & PULLEY	1
2		72140	KIT, FAN & PULLEY	1
3		72137	KIT, FAN & PULLEY	1
5		72135	KIT, FAN & PULLEY	1
6		72138	KIT, FAN & PULLEY	1
7		72134	KIT, FAN & PULLEY	1
8		72294	KIT, FAN & PULLEY	1
9		72126	KIT, FAN & PULLEY	1



T2 SERVICE SCHEMATIC

MODEL NUMBER:

T	2
1	2

 -

3	4	5	6

 -

7	8	9	10

 -

			*
11	12	13	14

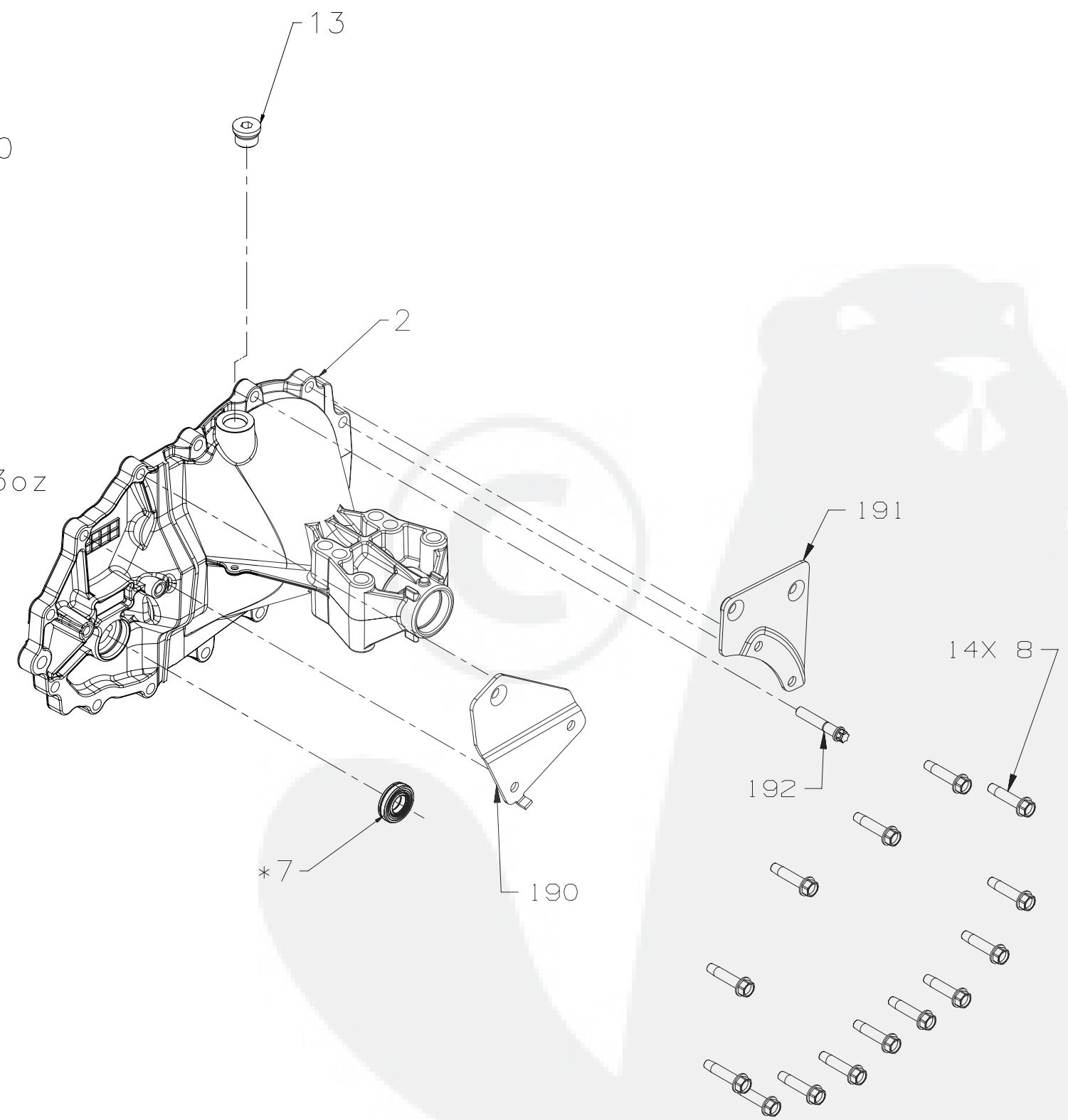
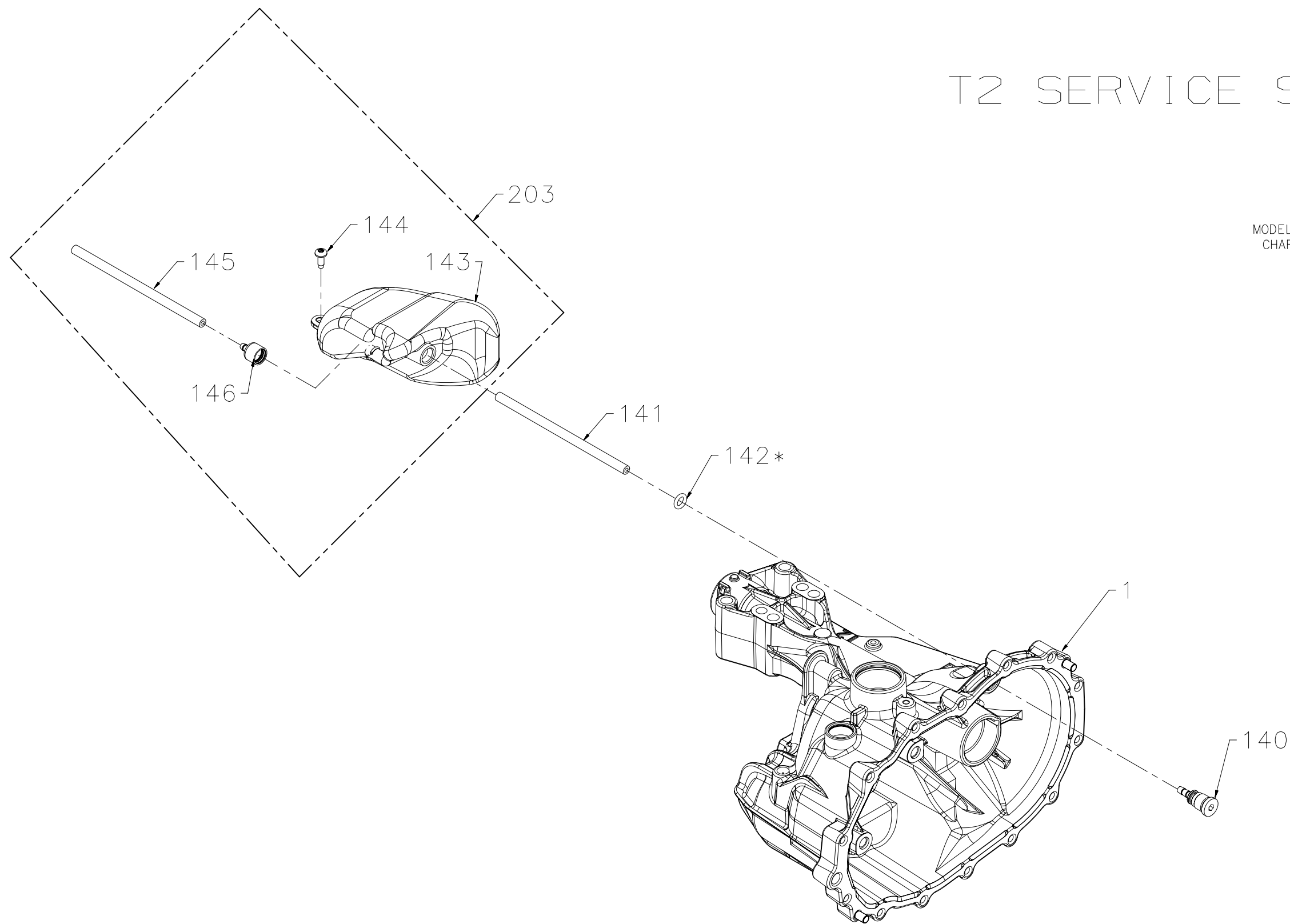

ITEMS NOT SHOWN:
10 SEALANT
11 OIL, 20W50, 69.3oz

HOUSING KITS

CHAR 14	ITEM	COMPONENT	DESCRIPTION	QTY
X	1,2	71703	KIT, HOUSING	1
	140	51143	5/16 SAE, 5/32 TUBE	1
	141	52474	HOSE	1
	142	51144	O-RING .103 X .299 ID	1
1	1	71546	MAIN HOUSING	1
	2	71547	SIDE HOUSING	1
	140	51143	5/16 SAE, 5/32 TUBE	1
	141	52474	HOSE	1
2	142	51144	O-RING .103 X .299 ID	1
	1	71887	MAIN HOUSING	1
	2	71547	SIDE HOUSING	1
	140	9005110-5000	PLUG, 1/2-20 STR THREAD SOCKET HEAD	1
3	1	71546	MAIN HOUSING	1
	2	72443	SIDE HOUSING	1
	140	51143	5/16 SAE, 5/32 TUBE	1
	141	52474	HOSE	1
	142	51144	O-RING .103 X .299 ID	1
	190	53734	BRACKET, FRONT AXLE	1
191	53735	BRACKET, REAR AXLE	1	
192	44876	BOLT, 1/4-20 X 1.38*	1	

COMMON PARTS

ITEM	COMPONENT	DESCRIPTION	QTY
7	52820	SEAL, LIP .50X1.0X.25 TC	1
8	51190	HFCS 1/4-20 X 1.25*	14
10	50928	SEALANT	1
11		OIL, 20W50	69.3oz
13	9005110-5600	PLUG 9/16-18 (METAL)	1
203	71549	KIT, E-TANK	1
205	71554	KIT, SEAL	1

* - PARTS INCLUDED IN 205 SEAL KIT

