

HC-156

Serial Number

38000001-38999999

Last updated date

27/Nov/2020

TABLE OF CONTENTS

CYLINDER, PISTON, CRANKSHAFT	1
CRANKCASE	3
MAGNETO.....	5
AIR CLEANER, CARBURETOR.....	7
CARBURETOR.....	9
FUEL TANK	11
MUFFLER.....	13
RECOIL STARTER.....	15
GEAR CASE	17
CUTTING BLADE	19
HANDLE.....	21
ACCESSORIES	23

CYLINDER, PISTON, CRANKSHAFT

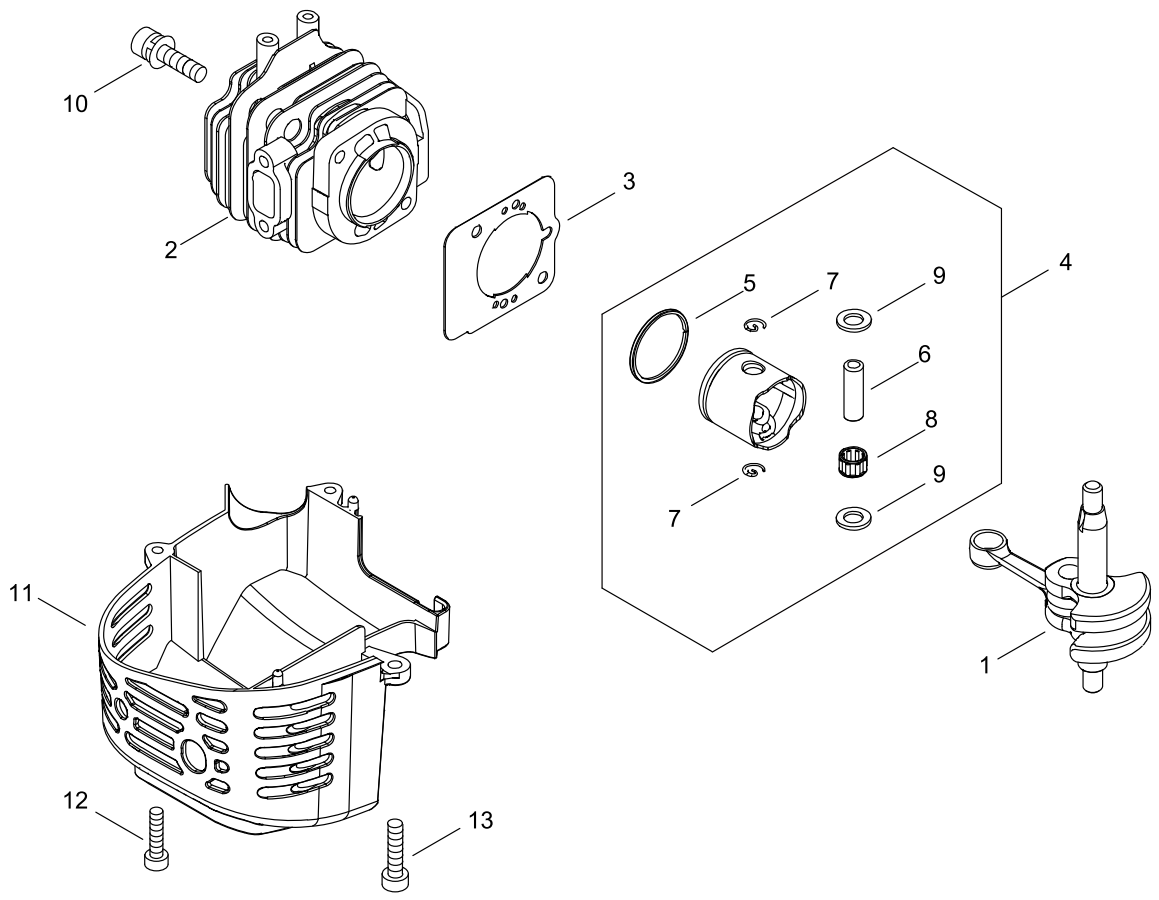

CYLINDER, PISTON, CRANKSHAFT

Key No.	LV (+)	Parts Number	Parts Description	Qty	Standard	Class
1		A011-000313	CRANKSHAFT,ASM	1		D
2		A130-000550	CYLINDER	1		D
3		V100-000160	GASKET,CYL	1		B
4		P021-007772	PISTON KIT	1		
5	+	A101-000090	RING,PISTON	1		B
6	+	100013-11520	PIN, PISTON	1		D
7	+	100015-04630	CIRCLIP, PISTON PIN	2		C
8	+	100113-05930	BEARING, NEEDLE	1	8*12*8	B
9	+	100014-08960	SPACER, PISTON PIN	2		C
10		900162-05022	BOLT, H.S. 5*22	2	5*22 W,SW	
11		A160-002590	COVER,CYLINDER	1		C
12		V804-000010	BOLT, TORX 4	2	TT-4*16 DG 10.9	C
13		V805-000150	BOLT, TORX 5	1	TB-5*16 10.9	C

Class : Consumable class

A:Fast moving parts B:Semi-fast moving parts C:Slow moving parts D:Order only as needed

CRANKCASE

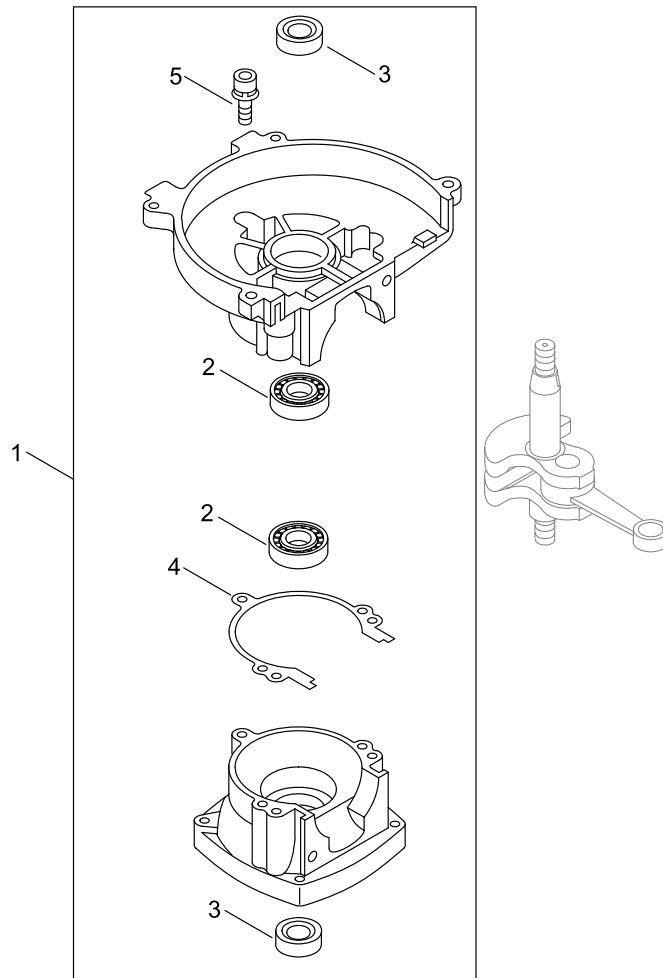

CRANKCASE

Key No.	LV (+)	Parts Number	Parts Description	Qty	Standard	Class
1		P100-003510	CRANKCASE SET	1		
2	+	94035-36201	BEARING BALL	2	6201X3JR2C3	
3	+	100212-42031	OILSEAL	2	ISCD 12*22*4.5	C
4	+	100242-42030	GASKET, CRANKCASE	1		B
5	+	900162-05028	BOLT, H.S. 5*28	3	5*28 W,SW	

Class : Consumable class

A:Fast moving parts B:Semi-fast moving parts C:Slow moving parts D:Order only as needed

MAGNETO

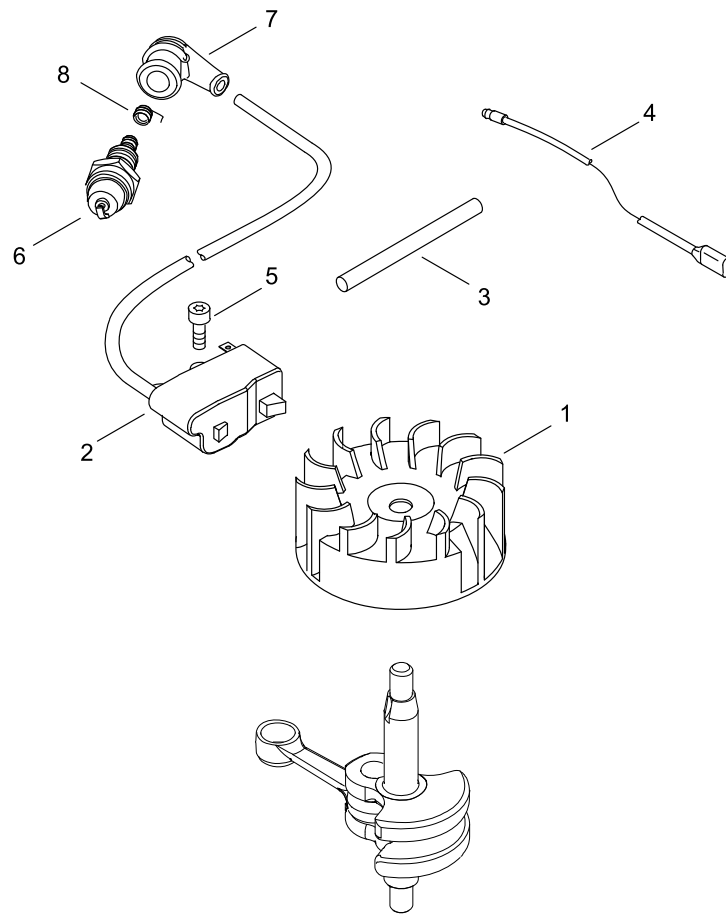

MAGNETO

Key No.	LV (+)	Parts Number	Parts Description	Qty	Standard	Class
1		A409-000150	ROTOR,MAGNETO	1		C
2		A411-000211	COIL,IGNITION	1	EMG-60D ID#C9822	C
3		V475-007510	TUBE	1		C
4		V485-000870	LEAD	1	L=190,#187,CA104	C
5		V804-000070	BOLT, TORX 4	2	TB-4*20 12.9	C
6		A425-000000	SPARKPLUG	1	BPMR8Y	A
7		A427-000013	CAP,SPARK PLUG	1		C
8		A426-000010	TERMINAL,SPARKPLUG	1		C

Class : Consumable class

A:Fast moving parts B:Semi-fast moving parts C:Slow moving parts D:Order only as needed

AIR CLEANER, CARBURETOR

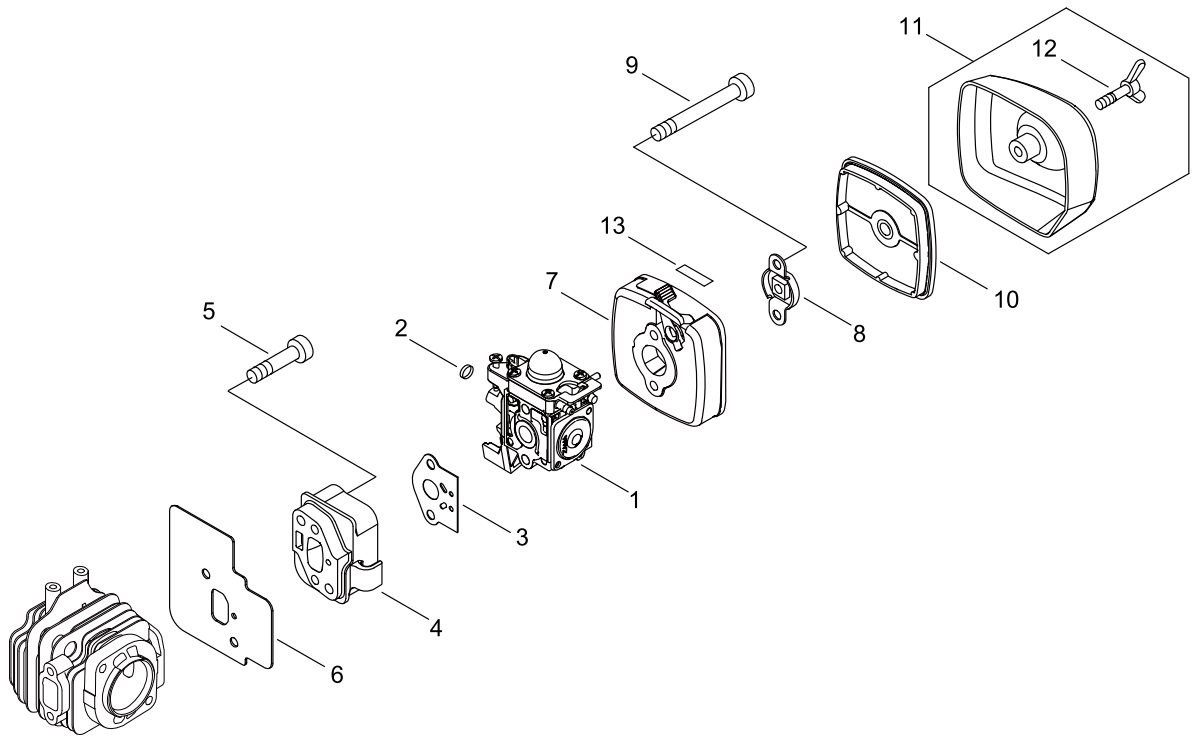

AIR CLEANER, CARBURETOR

Key No.	LV (+)	Parts Number	Parts Description	Qty	Standard	Class
1		A021-004740	CARBURETOR,DIAPHRAGM	1	ZAMA RB-K92A	B
2		V490-001100	CLIP	1		C
3		V103-001580	GASKET,INTAKE	1		A
4		A200-000300	INSULATOR, INTAKE	1		C
5		V805-000170	BOLT, TORX 5	2	TB-5*25 10.9	C
6		V103-001591	GASKET,INTAKE	1	T0.5	A
7		P021-049010	CASE,CLEANER	1		
8		129011-52730	PLATE, PREVENT	1		C
9		V805-000100	BOLT, TORX 5	2	TB-5*65 10.9	C
10		A226-001410	ELEMENT,AIR FILTER	1		A
11		P100-000110	CLEANER LID ASY	1		
12	+	210417-52730	BOLT, WING	1	5*20	C
13		890332-52730	LABEL, CHOKE	1		D

Class : Consumable class

A:Fast moving parts B:Semi-fast moving parts C:Slow moving parts D:Order only as needed

CARBURETOR

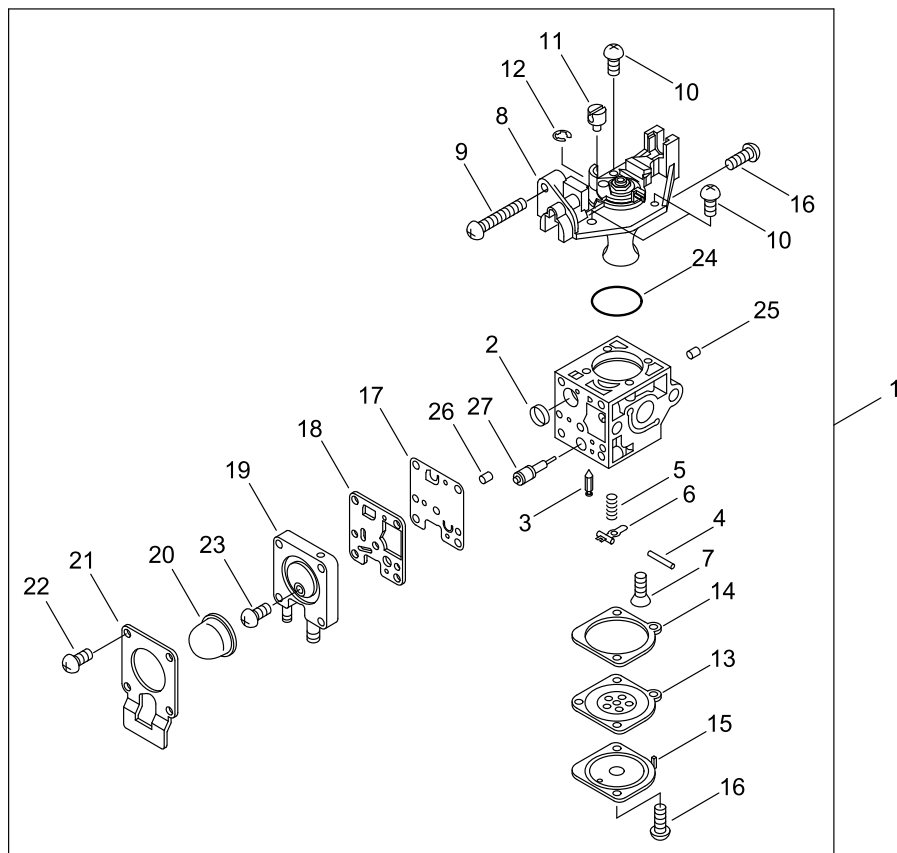

CARBURETOR

Key No.	LV (+)	Parts Number	Parts Description	Qty	Standard	Class
1		A021-004740	CARBURETOR,DIAPHRAGM	1	ZAMA RB-K92A	B
2	+	P005-000010	STRAINER	1		
3	+	125337-08260	VALVE, INLET NEEDLE	1		
4	+	125338-13930	PIN, METERING ARM	1		
5	+	P005-000940	SPRING, METER. LEVER	1		
6	+	125323-08260	ARM, VALVE	1		
7	+	125339-42030	SCREW	1		
8	+	P005-002050	COVER ASY, ROTOR	1		
9	+	P005-000100	SCREW,THROTTLEADJUST	1		
10	+	125344-13931	SCREW	3		
11	+	P005-002200	POST	1		
12	+	P005-000190	E-RING	1		
13	+	P005-002230	DIAPHRAGM ,METERING	1		A
14	+	P005-000200	GASKET, METERING	1		A
15	+	125342-52130	COVER, DIAPHRAGM	1		
16	+	125344-52130	SCREW	3		
17	+	P005-000510	DIAPHRAGM, PUMP	1		A
18	+	P005-000520	GASKET, PUMP	1		A
19	+	P005-002480	BASE ASY,PRIMER	1		
20	+	P005-003110	PUMP, PRIMER	1		
21	+	P005-000250	RETAINER	1		
22	+	P005-001900	SCREW	4		
23	+	P005-000270	SCREW	1		
24	+	P005-000280	O-RING	1		
25	+	P005-001000	ROLLER, GUIDE	1		
26	+	P005-001250	RETAINER,PLUG BALL	1		
27	+	P005-001260	SCREW,MAINN MIXTURE	1		

Class : Consumable class

A:Fast moving parts B:Semi-fast moving parts C:Slow moving parts D:Order only as needed

FUEL TANK

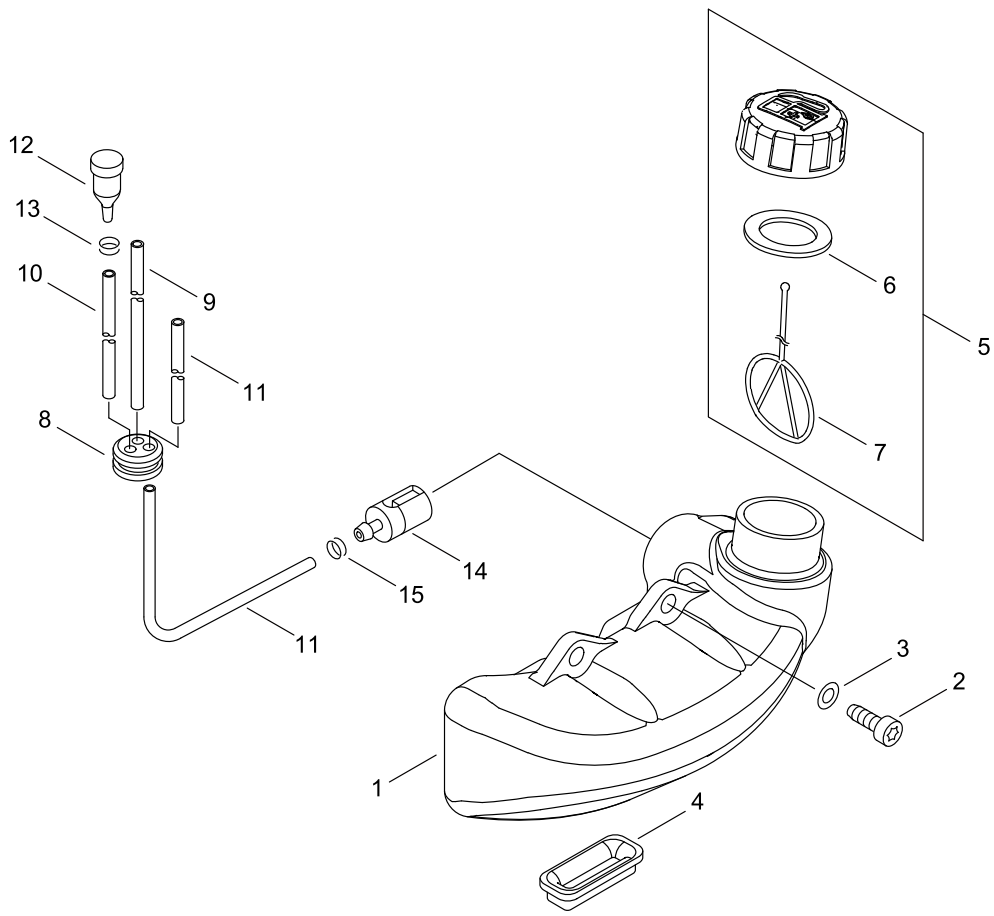

FUEL TANK

Key No.	LV (+)	Parts Number	Parts Description	Qty	Standard	Class
1		A350-000041	TANK,FUEL	1		C
2		V805-000000	BOLT, TORX 5	2	TT-5*16 DG 10.9	C
3		900603-00005	WASHER 5	2	5.5*12*0.8	
4		131920-61830	CUSHION, FUEL TANK	1		B
5		P021-012211	CAP,FUEL ASY	1		
6	+	V107-000190	GASKET,FUEL CAP	1	37.9* T 2.2	A
7	+	A365-000060	CONNECTOR,CAP	1	L=123	B
8		132115-46730	GROMMET, FUEL	1		C
9		V470-000581	PIPE	1	3*5*195	C
10		V471-001201	PIPE	1	3*5*70	C
11		132010-40830	PIPE 3* 6* 75	1	3*6*75 YL	C
12		A356-000031	VALVE,CHECK	1		B
13		V490-001240	CLIP	1		C
14		A369-000480	STRAINER, FUEL	1	125-959	A
15		V490-001240	CLIP	1		C

Class : Consumable class

A:Fast moving parts B:Semi-fast moving parts C:Slow moving parts D:Order only as needed

MUFFLER

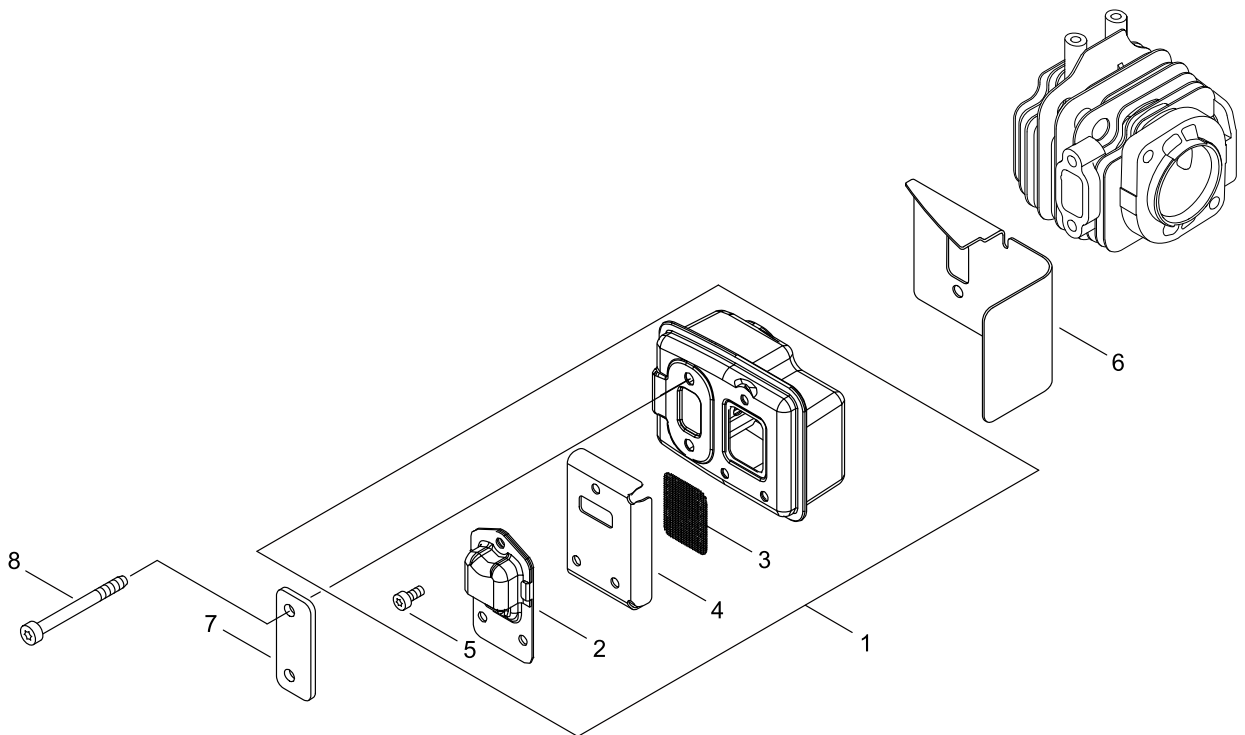

MUFFLER

Key No.	LV (+)	Parts Number	Parts Description	Qty	Standard	Class
1		P021-045640	MUFFLER ASY	1		
2	+	A313-000700	GUIDE,EXH	1	ID#1090	C
3	+	145862-40630	SCREEN, MUFFLER	1		B
4	+	V104-000072	GASKET,EXHAUST	1		A
5	+	V804-000030	BOLT, TORX 4	3	TB-4*8 10.9	C
6		V104-001990	GASKET,EXHAUST	1		A
7		V150-000371	PLATE,EYE	1		C
8		V805-000190	BOLT, TORX 5	2	TB-5*55 12.9	C

Class : Consumable class

A:Fast moving parts B:Semi-fast moving parts C:Slow moving parts D:Order only as needed

RECOIL STARTER

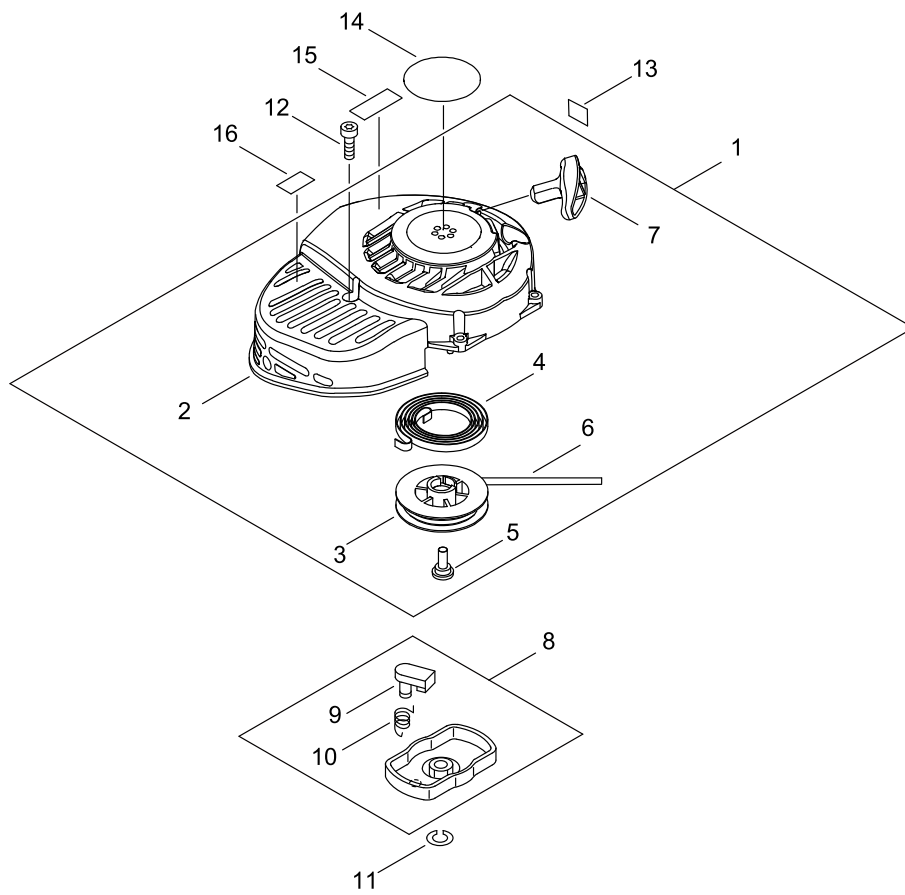

RECOIL STARTER

Key No.	LV (+)	Parts Number	Parts Description	Qty	Standard	Class
1		A051-002590	STARTER,RECOIL ASY	1		B
2	+	P022-039610	CASE, STARTER	1		
3	+	177215-44430	DRUM, STARTER	1		
4	+	177220-42030	SPRING, REWIND	1		
5	+	177236-44330	SCREW	1		
6	+	P022-006231	ROPE	1		
7	+	P022-023170	GRIP, STARTER	1		
8		A052-000160	PULLEY,ASM STARTER	1		C
9	+	177218-44330	PAWL, STARTER	2	BLACK	
10	+	177234-12220	SPRING, PAWL	2		
11		900605-00008	WASHER, SPRING 8	1	8	
12		V804-000060	BOLT, TORX 4	4	TB-4*16 10.9	C
13		X524-001901	LABEL	1		D
14		X502-000890	LABEL,ECHO	1		D
15		X543-004530	LABEL,MODEL	1		D
16		X505-002310	LABEL,CAUTION	1	HOT CAUTION	D

Class : Consumable class

A:Fast moving parts B:Semi-fast moving parts C:Slow moving parts D:Order only as needed

GEAR CASE

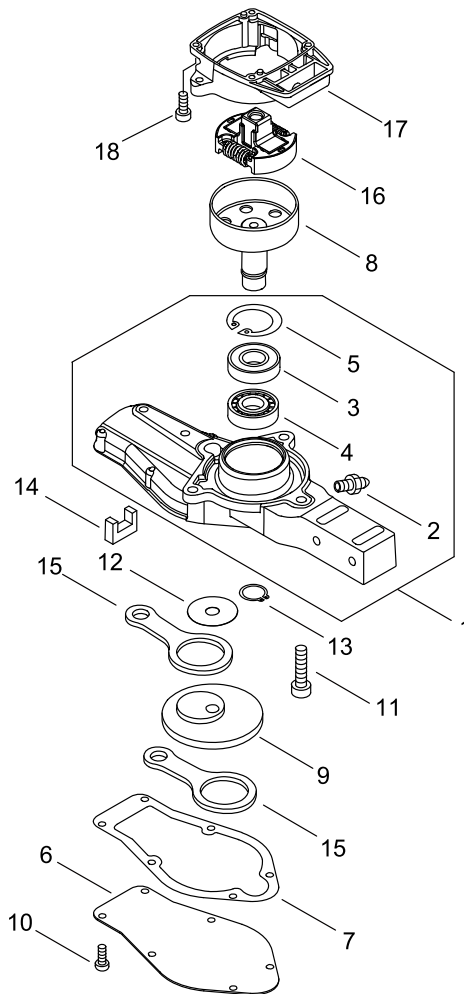

GEAR CASE

Key No.	LV (+)	Parts Number	Parts Description	Qty	Standard	Class
1		P100-007510	CASE ASY, GEAR	1		
2	+	880110-10860	NIPPLE, GREASE	1		
3	+	900812-06202	BEARING, BALL 6202	1	6202DDU(LLU)	
4	+	900810-36202	BEARING, BALL 6202	1	6202/C3	
5	+	900702-00035	CIRCLIP 35	1	CR-35	
6		610411-05361	LID, GEARCASE	1		D
7		610414-05360	GASKET, GEAR HOUSING	1		A
8		A556-001620	DRUM, CLUTCH	1	50 T:1.4	B
9		610312-04560	GEAR	1		C
10		V804-000040	BOLT, TORX 4	6	TB-4*10 10.9	C
11		V806-000130	BOLT, TORX 6	3		C
12		610350-04560	WASHER	1		C
13		900701-00014	CIRCLIP 14	1	CS-14	
14		610425-04560	SEAL	1		C
15		C532-000121	ROD, CONNECTING	2		C
16		A056-000740	CLUTCH ASY	1		B
17		A570-000310	CASE, CLUTCH	1		D
18		V804-000060	BOLT, TORX 4	4	TB-4*16 10.9	C

Class : Consumable class

A:Fast moving parts B:Semi-fast moving parts C:Slow moving parts D:Order only as needed

CUTTING BLADE

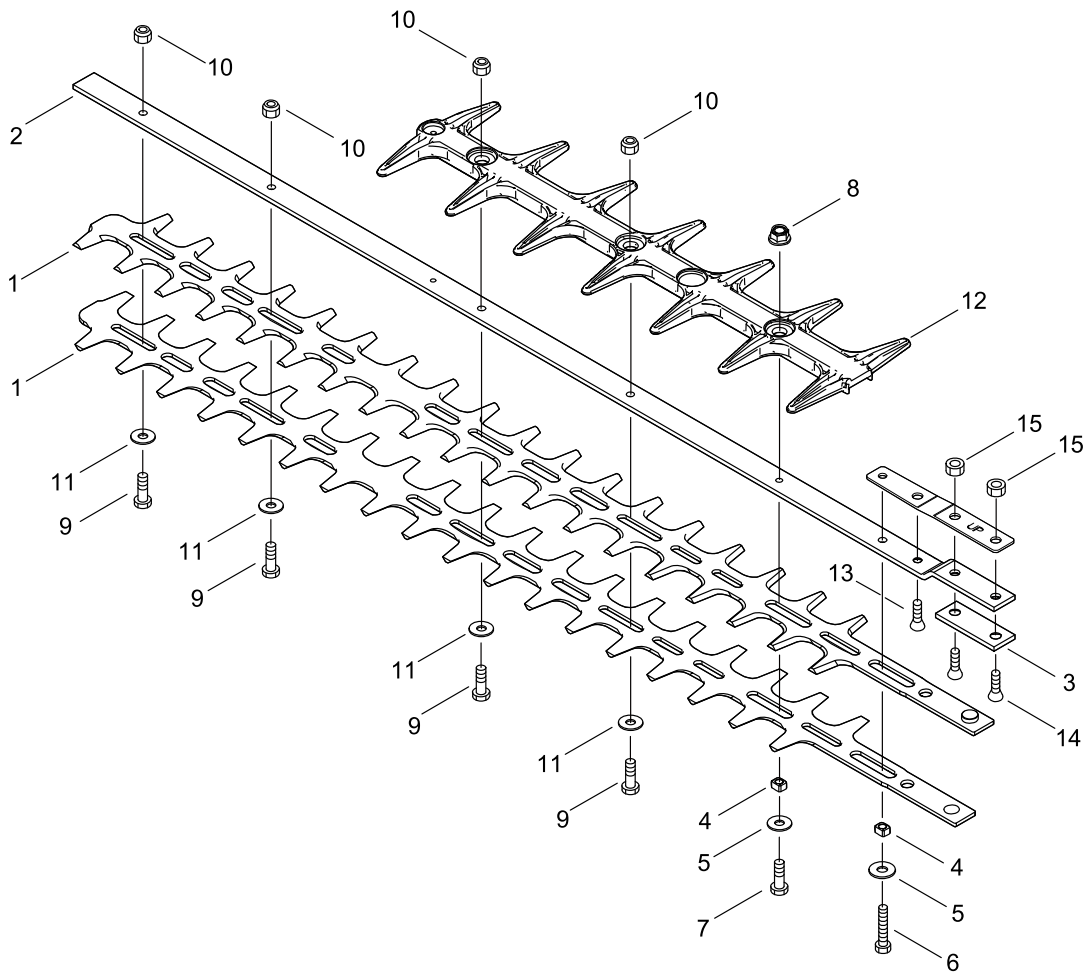

CUTTING BLADE

Key No.	LV (+)	Parts Number	Parts Description	Qty	Standard	Class
1		X412-000660	CUTTER	2		A
2		X425-000960	SUPPORT,CUTTER	1	L789 T3.2	B
3		610440-04560	HOLDER, FRAME	1		C
4		V353-000250	COLLAR	2	9*7.45*5.3	C
5		V303-000290	WASHER	2		C
6		V805-000270	BOLT, TORX 5	1	TB-5*40 12.9	C
7		V805-000160	BOLT, TORX 5	1	TB-5*20 10.9	C
8		92108-05000	NUT, FLANGE	1		
9		V204-000570	BOLT	4		C
10		433022-06460	NUT	4		C
11		V304-000240	WASHER	4		C
12		X431-000200	BLUNT	1		C
13		900212-05030	SCREW (5*30*P0.8)	1	+SF5*30	
14		900212-06025	SCREW 6*25	2	+SF6*25	
15		900500-00006	NUT 6	2	6	

Class : Consumable class

A:Fast moving parts B:Semi-fast moving parts C:Slow moving parts D:Order only as needed

HANDLE

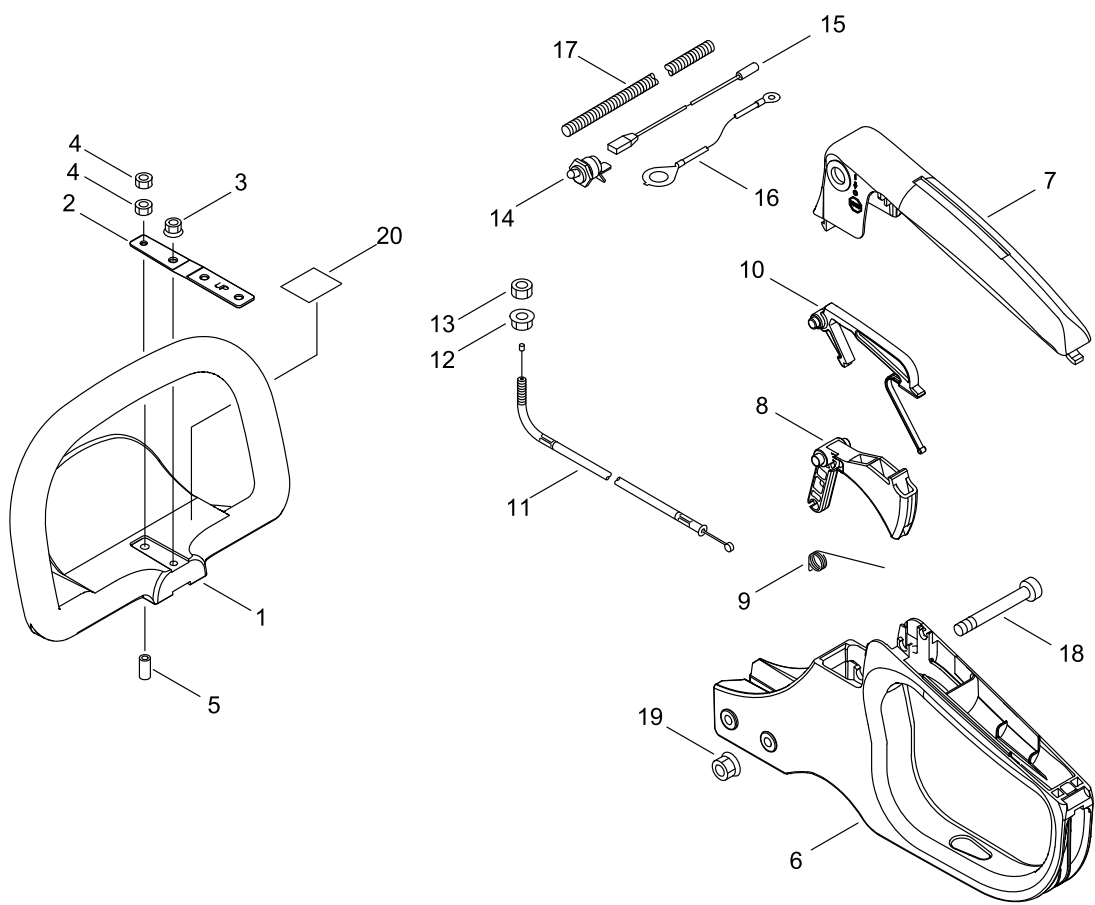

HANDLE

Key No.	LV (+)	Parts Number	Parts Description	Qty	Standard	Class
1		C400-000533	HANDLE, FRONT	1		C
2		V150-004010	PLATE,EYE	1		C
3		92108-05000	NUT, FLANGE	1		
4		900590-00005	NUT 5 #2	2	5 #2	
5		V353-000670	COLLAR,5	1	5*6.2*16.3	C
6		C410-000431	HANDLE, REAR	1	HC-155/HC-2020	C
7		C411-000030	LID,HANDLE	1		C
8		C450-000750	TRIGGER,THROTTLE	1		C
9		V452-000392	SPRING,TORSION	1	11.5 ID	B
10		C460-000120	LOCKOUT, THROTTLE	1		C
11		V430-004670	CABLE,BOWDEN	1		B
12		900515-00006	NUT, FLANGE 6	1	6	
13		900502-00006	NUT 6 (3N)	1	3N6	
14		163400-03460	SWITCH, IGNITION	1		C
15		V485-002540	LEAD	1		C
16		V485-002550	LEAD	1		C
17		V475-001280	TUBE	1	7*140 コルゲート	C
18		V805-000280	BOLT, TORX 5	2	TB-5*45 10.9	C
19		92108-05000	NUT, FLANGE	2		
20		X505-002030	LABEL,CAUTION	1	37*35	D

Class : Consumable class

A:Fast moving parts B:Semi-fast moving parts C:Slow moving parts D:Order only as needed

ACCESSORIES

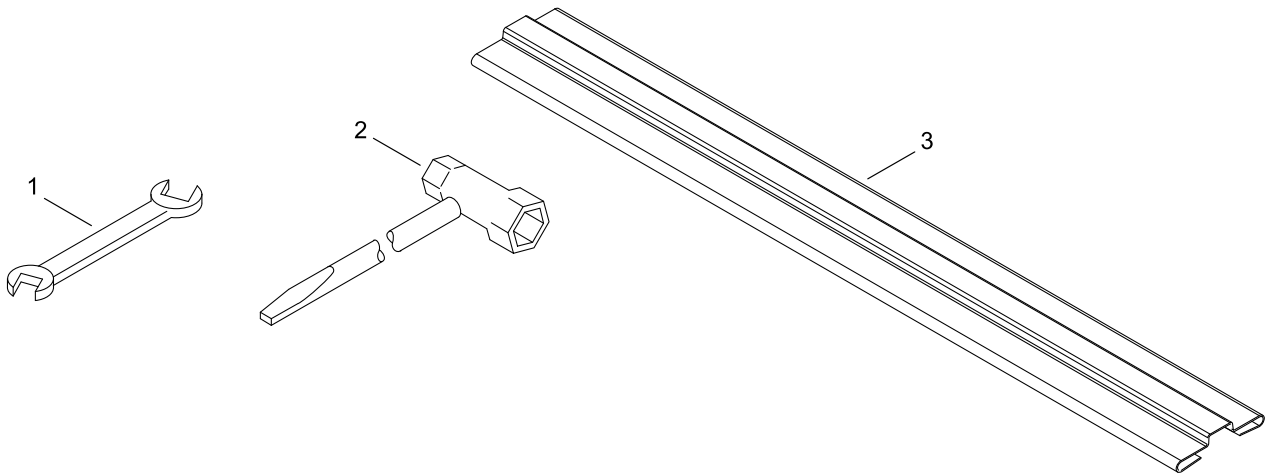

ACCESSORIES

Key No.	LV (+)	Parts Number	Parts Description	Qty	Standard	Class
1		895112-00330	SPANNER 8*10	1		D
2		895410-03930	WRENCH, W/S. DRIVER	1		D
3		X495-000820	SCABBARD, BLADE	1	L700	D

Class : Consumable class

A:Fast moving parts B:Semi-fast moving parts C:Slow moving parts D:Order only as needed

NUMERICAL PARTS INDEX

Part No	Part description	Page	Part No	Part description	Page	Part No	Part description	Page
100013-11520	PIN, PISTON	2	900605-00008	WASHER, SPRING 8	16	P005-000510	DIAPHRAGM, PUMP	10
100014-08960	SPACER, PISTON PIN	2	900701-00014	CIRCLIP 14	18	P005-000520	GASKET, PUMP	10
100015-04630	CIRCLIP, PISTON PIN	2	900702-00035	CIRCLIP 35	18	P005-000940	SPRING, METER. LEVER	10
100113-05930	BEARING, NEEDLE	2	900810-36202	BEARING, BALL 6202	18	P005-001000	ROLLER, GUIDE	10
100212-42031	OILSEAL	4	900812-06202	BEARING, BALL 6202	18	P005-001250	RETAINER,PLUG BALL	10
100242-42030	GASKET, CRANKCASE	4	92108-05000	NUT, FLANGE	20	P005-001260	SCREW,MAINN MIXTURE	10
125323-08260	ARM, VALVE	10	92108-05000	NUT, FLANGE	22	P005-001900	SCREW	10
125337-08260	VALVE, INLET NEEDLE	10	94035-36201	BEARING BALL	4	P005-002050	COVER ASY, ROTOR	10
125338-13930	PIN, METERING ARM	10	A011-000313	CRANKSHAFT,ASM	2	P005-002200	POST	10
125339-42030	SCREW	10	A021-004740	CARBURETOR, DIAPHRAGM	8	P005-002230	DIAPHRAGM ,METERING	10
125342-52130	COVER, DIAPHRAGM	10	A021-004740	CARBURETOR, DIAPHRAGM	10	P005-002480	BASE ASY,PRIMER	10
125344-13931	SCREW	10	A051-002590	STARTER,RECOIL ASY	16	P005-003110	PUMP, PRIMER	10
125344-52130	SCREW	10	A052-000160	PULLEY,ASM STARTER	16	P021-007772	PISTON KIT	2
129011-52730	PLATE, PREVENT	8	A056-000740	CLUTCH ASY	18	P021-012211	CAP,FUEL ASY	12
131920-61830	CUSHION, FUEL TANK	12	A101-000090	RING,PISTON	2	P021-045640	MUFFLER ASY	14
132010-40830	PIPE 3* 6* 75	12	A130-000550	CYLINDER	2	P021-049010	CASE,CLEANER	8
132115-46730	GROMMET, FUEL	12	A160-002590	COVER,CYLINDER	2	P022-006231	ROPE	16
145862-40630	SCREEN, MUFFLER	14	A200-000300	INSULATOR, INTAKE	8	P022-023170	GRIP, STARTER	16
163400-03460	SWITCH, IGNITION	22	A226-001410	ELEMENT,AIR FILTER	8	P022-039610	CASE, STARTER	16
177215-44430	DRUM, STARTER	16	A313-000700	GUIDE,EXH	14	P100-000110	CLEANER LID ASY	8
177218-44330	PAWL, STARTER	16	A350-000041	TANK,FUEL	12	P100-003510	CRANKCASE SET	4
177220-42030	SPRING, REWIND	16	A356-000031	VALVE,CHECK	12	P100-007510	CASE ASY, GEAR	18
177234-12220	SPRING, PAWL	16	A365-000060	CONNECTOR,CAP	12	V100-000160	GASKET,CYL	2
177236-44330	SCREW	16	A369-000480	STRAINER, FUEL	12	V103-001580	GASKET,INTAKE	8
210417-52730	BOLT, WING	8	A409-000150	ROTOR,MAGNETO	6	V103-001591	GASKET,INTAKE	8
433022-06460	NUT	20	A411-000211	COIL,IGNITION	6	V104-000072	GASKET,EXHAUST	14
610312-04560	GEAR	18	A425-000000	SPARKPLUG	6	V104-001990	GASKET,EXHAUST	14
610350-04560	WASHER	18	A426-000010	TERMINAL,SPARKPLUG	6	V107-000190	GASKET,FUEL CAP	12
610411-05361	LID, GEARCASE	18	A427-000013	CAP,SPARK PLUG	6	V150-000371	PLATE,EYE	14
610414-05360	GASKET, GEAR HOUSING	18	A556-001620	DRUM, CLUTCH	18	V150-004010	PLATE,EYE	22
610425-04560	SEAL	18	A570-000310	CASE,CLUTCH	18	V204-000570	BOLT	20
610440-04560	HOLDER, FRAME	20	C400-000533	HANDLE, FRONT	22	V303-000290	WASHER	20
880110-10860	NIPPLE, GREASE	18	C410-000431	HANDLE, REAR	22	V304-000240	WASHER	20
890332-52730	LABEL, CHOKE	8	C411-000030	LID,HANDLE	22	V353-000250	COLLAR	20
895112-00330	SPANNER 8*10	24	C450-000750	TRIGGER,THROTTLE	22	V353-000670	COLLAR,5	22
895410-03930	WRENCH, W/S. DRIVER	24	C460-000120	LOCKOUT, THROTTLE	22	V430-004670	CABLE,BOWDEN	22
900162-05022	BOLT, H.S. 5*22	2	C532-000121	ROD, CONNECTING	18	V452-000392	SPRING,TORSION	22
900162-05028	BOLT, H.S. 5*28	4	P005-000010	STRAINER	10	V470-000581	PIPE	12
900212-05030	SCREW (5*30*P0.8)	20	P005-000100	SCREW, THROTTLEADJUST	10	V471-001201	PIPE	12
900212-06025	SCREW 6*25	20	P005-000190	E-RING	10	V475-001280	TUBE	22
900500-00006	NUT 6	20	P005-000200	GASKET, METERING	10	V475-007510	TUBE	6
900502-00006	NUT 6 (3N)	22	P005-000250	RETAINER	10	V485-000870	LEAD	6
900515-00006	NUT, FLANGE 6	22	P005-000270	SCREW	10	V485-002540	LEAD	22
900590-00005	NUT 5 #2	22	P005-000280	O-RING	10	V485-002550	LEAD	22
900603-00005	WASHER 5	12				V490-001100	CLIP	8

NUMERICAL PARTS INDEX

Part No	Part description	Page
V490-001240	CLIP	12
V804-000010	BOLT, TORX 4	2
V804-000030	BOLT, TORX 4	14
V804-000040	BOLT, TORX 4	18
V804-000060	BOLT, TORX 4	16
V804-000060	BOLT, TORX 4	18
V804-000070	BOLT, TORX 4	6
V805-000000	BOLT, TORX 5	12
V805-000100	BOLT, TORX 5	8
V805-000150	BOLT, TORX 5	2
V805-000160	BOLT, TORX 5	20
V805-000170	BOLT, TORX 5	8
V805-000190	BOLT, TORX 5	14
V805-000270	BOLT, TORX 5	20
V805-000280	BOLT, TORX 5	22
V806-000130	BOLT, TORX 6	18
X412-000660	CUTTER	20
X425-000960	SUPPORT,CUTTER	20
X431-000200	BLUNT	20
X495-000820	SCABBARD,BLADE	24
X502-000890	LABEL,ECHO	16
X505-002030	LABEL,CAUTION	22
X505-002310	LABEL,CAUTION	16
X524-001901	LABEL	16
X543-004530	LABEL,MODEL	16