

Stand 01.03.2002

# ERSATZTEILLISTE

## ECHO Motorsäge CS-750EVL

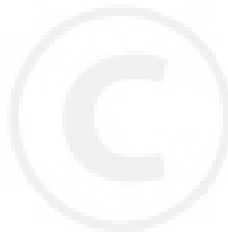

ECHO-Motorgeräte  
Vertrieb Deutschland GmbH  
Otto-Schott-Str. 7

72555 Metzingen

Telefon 07123-1091  
Telefax 07123-2589  
<http://www.echo-shop.de>  
email: [info@echo-shop.de](mailto:info@echo-shop.de)

## PARTS CATALOGUE

## (1) Power head and Muffler

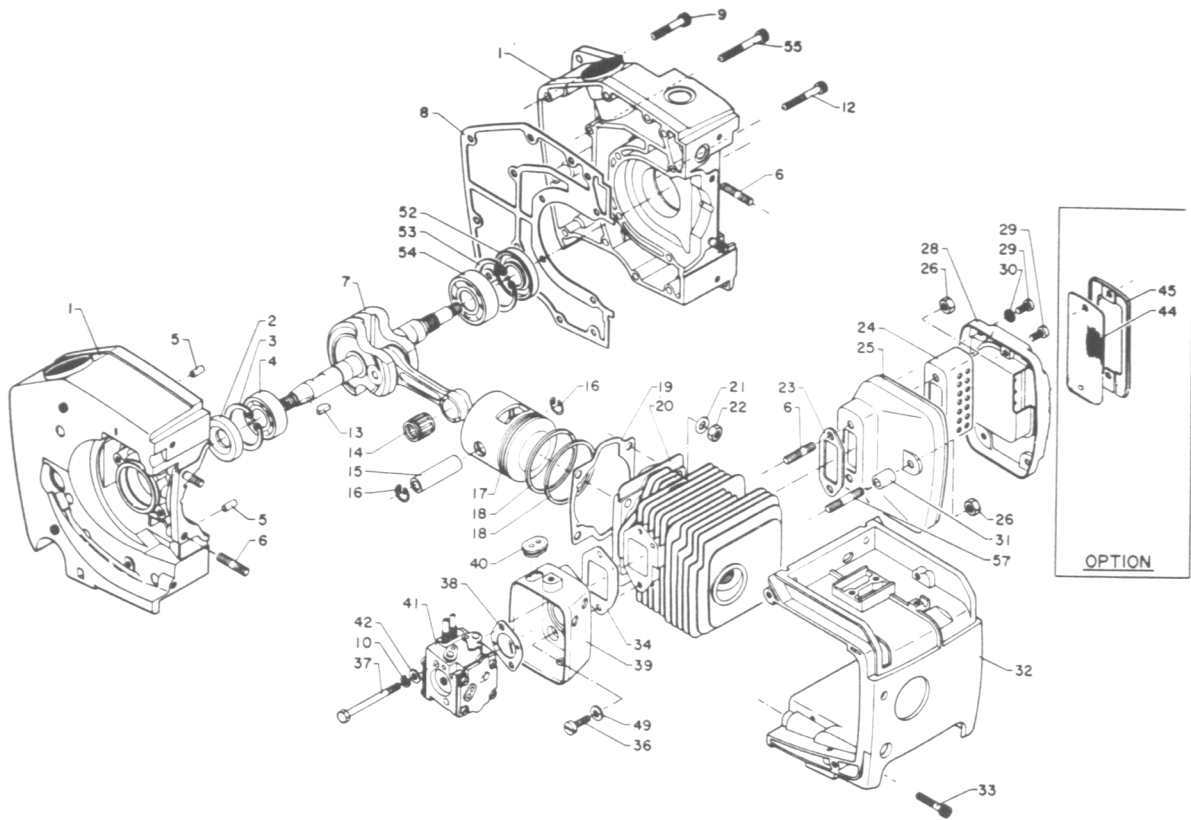

Key No.	Part No.	Q'ty	Description	Key No.	Part No.	Q'ty	Description
1-1*	100 200-1213 2		<b>Crankcase set</b>	1-	26	145 710-0023 0	Lock nut 6
5	-100 215-0283 0		Knock pin	28	145 808-0373 0		Lid, muffler
2	100 213-0283 0		Oil seal	29	145 643-0373 0		Screw 5x8
3	900 702-0003 5		Circlip 35	30	900 610-0000 5		Lock washer
4	900 810-0620 2		Ball bearing 6202	31	145 666-1243 0		Spacer
6	100 214-0283 0		Stud bolt	32	101 514-1023 2		Cylinder cover
7	100 100-1243 0		Crankshaft ass'y	33	900 162-0502 0		H.S.H. bolt 5x20
8	100 242-1023 0		Gasket, crankcase	34	130 010-1243 0		Gasket
9	900 162-0503 0		H.S.H. bolt 5x30	36	130 015-1023 0		Screw
10	900 605-0000 5		Spring washer 5	37	130 021-1243 0		Bolt
12	900 162-0503 5		H.S.H. bolt 5x35	38	130 016-1243 0		Gasket, carburetor
13	900 322-0301 4		Woodruff key	39	130 306-1243 0		Case, carburetor
14	100 012-0283 0		Needle bearing	40	129 010-0343 0		Grommet
15	100 013-0373 0		Piston pin	41	123 000-1243 0		Carburetor ass'y
16	100 015-0023 0		Circlip, piston pin	42	178 516-0083 0		Washer
17	100 010-1243 0		Piston	49	130 031-1023 0		Washer
18	100 011-1243 0		Piston ring	52	100 212-1213 0		Oil seal
19	101 010-1243 0		Gasket, cylinder base	53	900 702-0004 0		Circlip 40
20	101 011-1243 0		Cylinder	54	900 810-0620 3		Ball bearing 6203
21	900 600-0000 6		Washer	55	900 162-0504 0		H.S.H. bolt 5x40
22	900 500-0000 6		Nut	57	100 266-7302 0		Stud bolt
23	145 510-0373 0		Gasket, muffler	<b>Options:</b>			
24	145 612-0373 0		Silenser	44	145 862-0343 1		Screen
25	145 605-0373 1		Muffler	45	145 863-0343 1		Screen holder

Remarks:

\* Consisting of 1A, 1B and 5.

*ALW... H...  
145 627-12430*

(2) Air cleaner, Magneto and Recoil starter

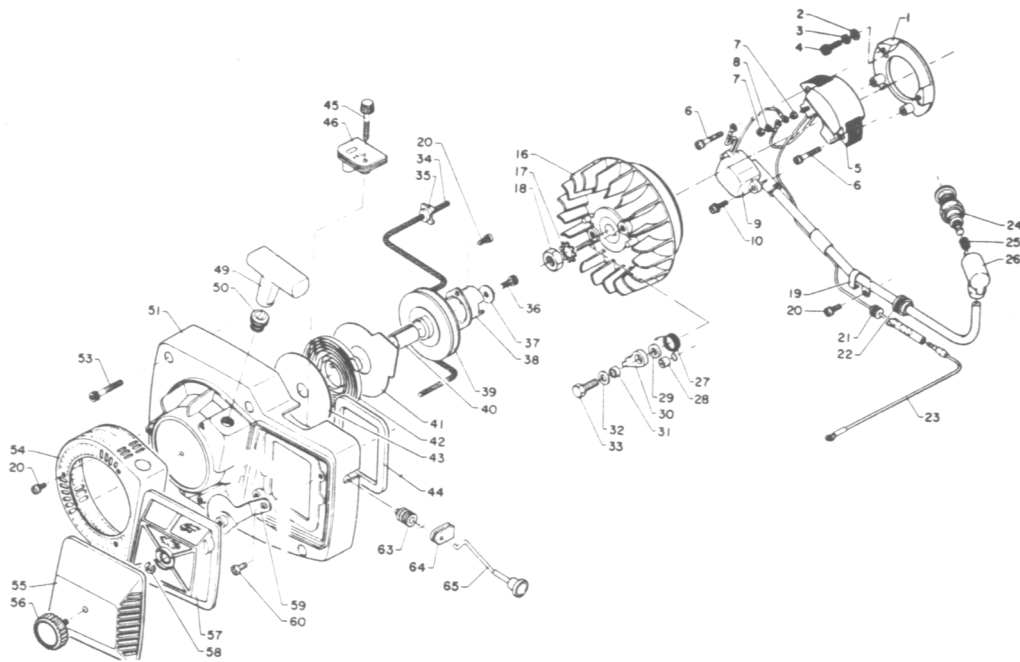

Key No.	Part No.	Q'ty	Description	Key No.	Part No.	Q'ty	Description
2- *	<b>150 002-1203 1</b>		<b>Magneto ass'y</b>	2- 37	-177 214-0283 0		Washer
1	-150 629-1203 1		Stator plate	38	-177 243-0283 3		Pawl catcher
5	-150 601-1203 0		C.D. ignition module	39	-177 215-0283 4		Recoil drum
6	-900 241-0402 5		Screw 4x25 w/SW	40	-177 216-0283 2		Bush
7	-900 500-0000 3		Nut 3	41	-177 242-0283 2		Side plate
8	-900 605-0000 3		Spring washer 3	42	-177 220-0283 4		Rewind spring
9	-150 626-1203 0		Ignition coil	43	-177 221-0283 0		Side plate
10	-900 242-0401 4		Screw 4x14 w/W,SW	49	-177 228-1233 0		Starter handle
16	-150 801-1023 0		Flywheel	50	-177 227-1063 0		Rope guide
2	900 600-0000 5		Washer 5	51	-101 507-1243 1		Fan cover
3	900 605-0000 5		Spring washer 5	54	-100 616-0283 1		Dust filter
4	900 105-0501 5		H.S.H. bolt 5x15	44	130 320-1243 0		Seal
17	900 611-0001 0		Lock washer 10	45	178 007-0343 0		Set screw, idle
18	100 144-0283 0		Nut	46	178 212-1243 0		Grommet
19	159 110-1023 0		Clamp				
20	900 241-0401 0		Screw 4x10 w/SW	53	900 162-0503 0		H.S.H. bolt 5x30
21	154 111-0343 0		Grommet	55	130 313-1243 0		Cover, air cleaner
22	153 110-0283 0		Grommet	56	130 406-1023 0		Thumb bolt
23	156 131-0373 1		Ground lead	57	130 305-1243 0		Air filter
24	159 010-1063 0		Spark plug	58	900 700-0000 4		E ring 4
25	159 011-0343 2		Coil spring, plug cap	59	130 405-1243 0		Bracket, air cleaner
26	159 012-0343 3		Cap, spark plug	60	900 220-0501 0		Screw 5x10
27	177 234-0283 1		Ratchet spring	63	178 211-0033 0		Grommet
28	177 245-0283 0		Cap	64	178 810-1243 0		Grommet
29	178 020-0031 0		Washer	65	178 510-1243 0		Choke rod
30	177 218-0283 0		Ratchet				
31	177 247-0283 0		Spacer, ratchet				
32	900 600-0000 6		Washer 6				
33	900 100-0601 6		Bolt 6x16				
**	<b>177 200-1243 0</b>		<b>Recoil starter ass'y</b>				
20	-900 241-0401 0		Screw 4x10 w/SW				
34	-177 226-0283 0		Starter rope				
35	-177 246-0283 2		Clip				
36	-900 162-0501 4		H S H. bolt 5x14				

Remarks:

\* Consisting of 1, 5 thru 10 and 16.

\*\* Consisting of 3, 20, 34 thru 43, 47 thru 51 and 54.

(3) Fuel and Chain oil line

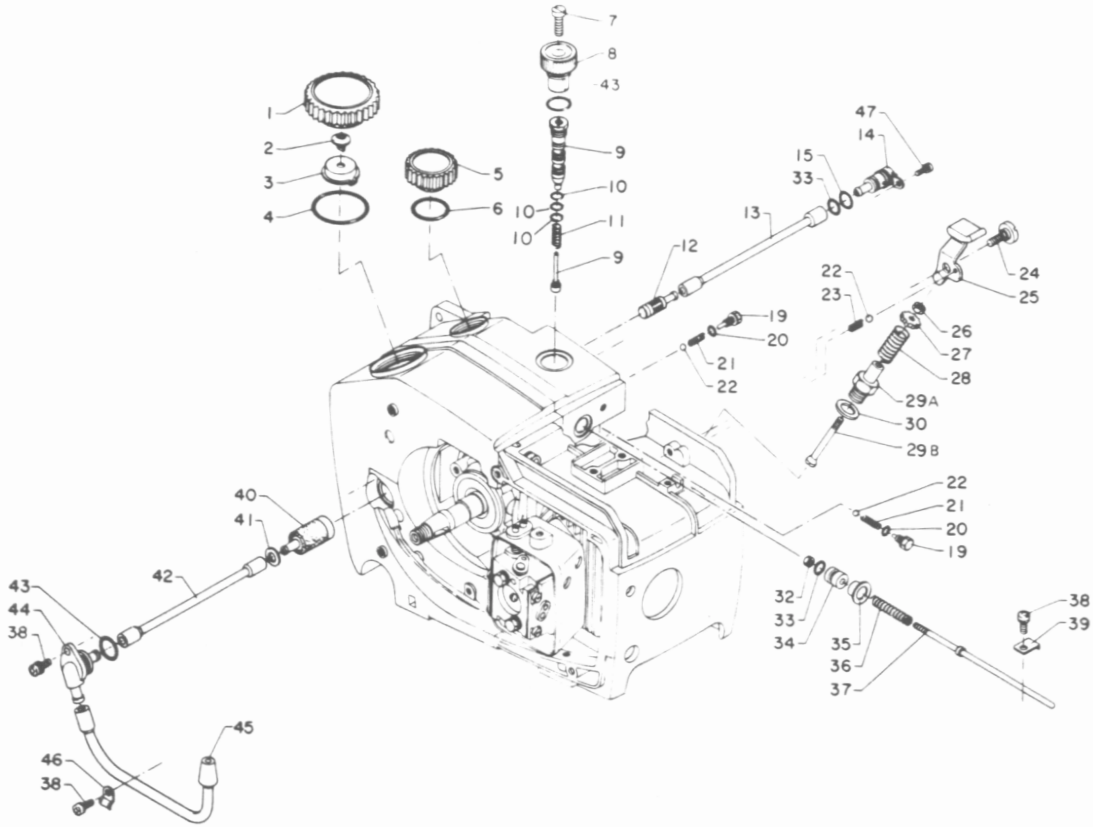

Key No.	Part No.	Q'ty	Description	Key No.	Part No.	Q'ty	Description
3- *	<b>131 004-1023 1</b>		<b>Cap ass'y, fuel tank</b>	3- 25	179 805-1243 0		Lever, decomp.
**	-131 001-1023 1		Cap ass'y, fuel tank	****	<b>101 100-0283 1</b>		<b>Decomp. ass'y</b>
1	-131 017-1023 1		Cap, fuel tank	26	-900 500-0000 4		Nut 4
2	-131 314-0033 0		Check valve	27	-101 114-0283 1		Washer
3	-131 015-0083 0		Holder, check valve	28	-101 113-0283 0		Spring
4	-900 720-0002 9		O-ring 29	30	101 112-0283 0		Gasket, decomp. valve
***	<b>436 001-1063 2</b>		<b>Cap ass'y, oil tank</b>	32	900 500-0000 3		Nut 3
5	-436 000-1063 2		Cap, oil tank	33	900 720-0000 6		O-ring 6
6	-900 720-0002 5		O-ring 25	34	707 015-0343 1		Plunger
7	<b>900 2200-005014</b>		Screw	35	707 022-0343 0		Retainer
8	437 039-1023 2		Dial, auto oiler	36	437 111-0343 1		Spring
9	437 002-1023 1		Plunger & cyl. set	37	707 006-1023 0		Pump rod
10	437 020-0283 0		O-ring	38	900 242-0401 0		Screw 4x10 w/W, SW
11	437 019-0283 0		Spring, pump plunger	39	707 111-0343 0		Clamp
12	436 205-0283 2		Oil strainer	40	131 200-0523 0		Fuel strainer
13	437 211-1213 0		Oil pipe	41	900 600-0000 6		Washer 6
14	437 306-1103 0		Connector	42	437 310-1023 1		Fuel pipe
15	900 720-0000 7		O-ring 7	43	900 720-0001 2		O-ring 12
19	437 121-0343 0		Plug	44	132 011-0343 1		Connector
20	437 122-0343 0		O-ring	45	132 018 1023 1		Fuel pipe
21	437 013-0033 0		Valve spring	46	132 112-0393 0		Clamp
22	100 225-0393 0		Ball	47	900 241-0300 8		Screw 3x8 w/SW
23	179 817-0363 0		Spring				
24	179 816-0363 0		Screw				

Remarks:  
 \* Consisting of \*\* and 4.  
 \*\* Consisting of 1 thru 3.  
 \*\*\* Consisting of 5 and 6.  
 \*\*\*\* Consisting of 26 thru 29(A) and 29(B)

(4) Handle and Spike bumper

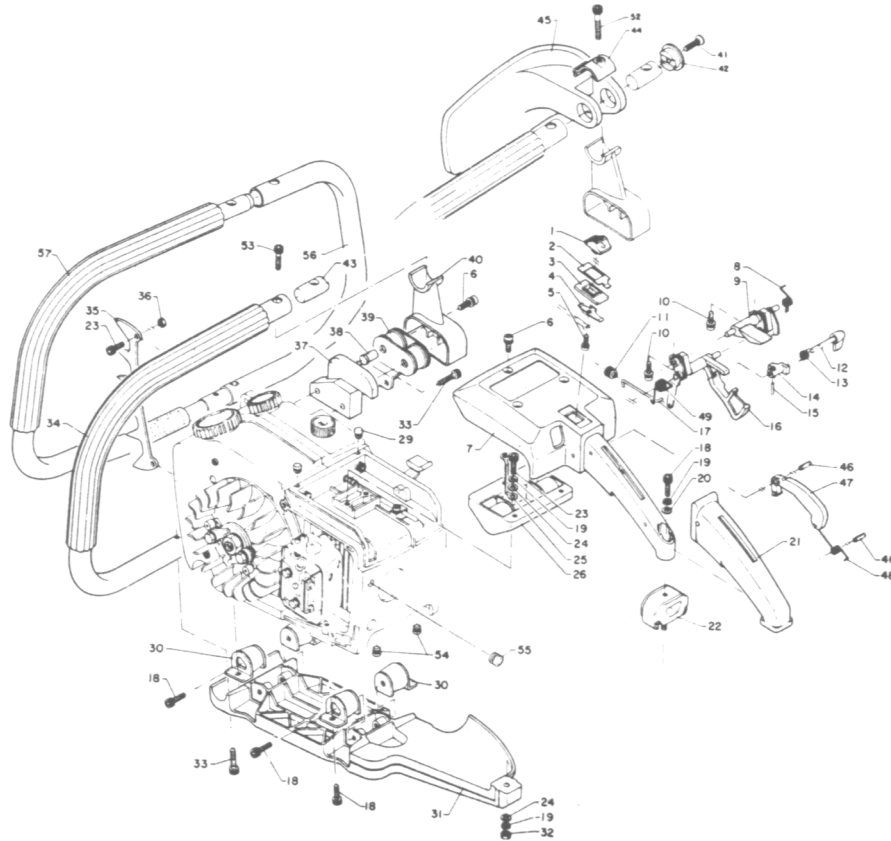

Key No.	Part No.	Q'ty	Description	Key No.	Part No.	Q'ty	Description
4- 1	163 410-0283 0		Body, switch	4- 33	900 162-0502 0		H.S.H. bolt 5x20
2	163 413-0283 0		Ground plate	34	351 606-1023 1		Front handle
3	163 411-0283 0		Guide, switch	35	880 210-0283 0		Spike bumper
4	163 412-0063 0		Spring, switch	36	433 020-0083 0		Lock nut 5
5	900 241-0401 0		Screw 4x10 w/SW	37	351 631-1213 0		Supporter
6	900 242-0501 4		Screw 5x14 w/W, SW	38	351 637 1023 0		Stopper
7	351 110-1023 1		Rear handle	39	351 605-1023 1		Cushion
8	707 017-0343 0		Spring	40	351 614-1193 0		Supporter
9	707 005-1023 0		Pump lever	41	900 214-0501 6		Screw 5x16
10	900 242-0401 4		Screw 4x14 w/W, SW	42	351 833-1023 0		Retainer
11	178 211-0033 0		Grommet	43	351 617-1023 0		Insert
12	178 008-1023 0		Lock lever, throttle	44	351 834-1023 0		Stopper
13	178 013-0343 0		Spring throttle lock	45	351 826-1023 0		Hand guard, front
14	178 012-1103 0		Throttle lock	46	900 340-4001 6		Spring pin 4x16
15	900 340-1601 0		Spring pin 1.6x10	47	178 090-1103 1		Safety lock
16	178 005-1023 1		Throttle trigger	48	178 091-1053 1		Spring, safety lock
17	178 011-1243 0		Throttle rod	49	178 043-1023 1		Spring, throttle return
18	900 162-0501 4		H.S.H. bolt 5x14	52	900 162-0503 5		H.S.H. bolt 5x35
19	900 605-0000 5		Spring washer 5	54	100 252-1023 0		Cushion
21	351 111-1023 1		Grip, rear handle	55	101 578 1243 0		Plug
22	351 107-1023 1		Cushion	<b>Options:</b>			
23	900 105-0501 2		H.S.H. bolt 5x12	53	900 162-0502 5		H.S.H. bolt 5x25
24	900 600-0000 5		Washer 5	*	<b>351 400-1033 1</b>		<b>Loop handle ass'y</b>
25	162 010-0343 1		Ground lead	56	-351 407-1033 1		Loop handle, R
26	351 105-1023 0		Cushion	57	-351 405-1033 0		Loop handle, L
29	100 251-1023 0		Cushion	<b>Remarks:</b>			
30	100 910-1023 1		Cushion	* Consisting of 56 and 57.			
31	351 613-1023 1		Supporter				
32	900 500-0000 5		Nut 5				

## (5) Chain and Chain brake (option), Clutch, Guide bar

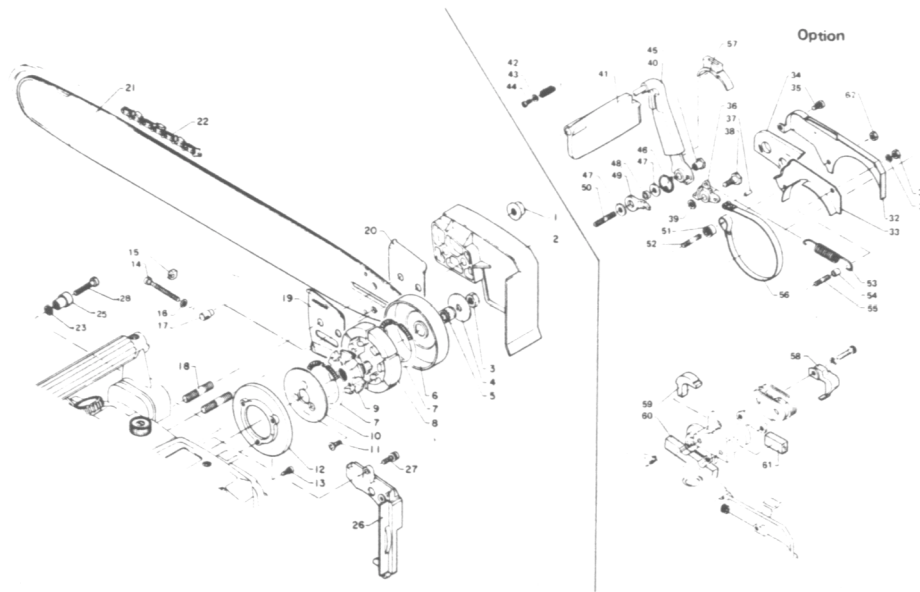

Key No.	Part No.	Q'ty	Description	Key No.	Part No.	Q'ty	Description
5- 1	433 019-1233 0		Frange nut	5- 34	-433 313-1213 0		Seal
2	433 010-1243 1		Cover, guide bar	35	-900 220-0500 8		Screw 5x8
3	100 129-0343 0		Nut, 8-L-H	36	-433 119-1103 0		Lever, brake band
4	175 015-0343 0		Washer	37	-900 340-4000 8		Spring pin 4x8
5	100 012-1233 0		Needle bearing	38	-433 120-1103 0		Bolt
6	175 005-1213 1		Clutch drum	39	-900 600-0000 6		Washer 6
*	<b>175 000-1023 0</b>		<b>Clutch ass'y</b>	***	<b>-433 201-1213 0</b>		<b>Brake handle ass'y</b>
7	-175 018-1023 0		Clutch spring	40	-433 105-1213 1		Brake handle
8	-175 017-0043 0		Clutch shoe	41	-433 145-1113 0		Brake handle (B)
9	-175 016-1023 0		Clutch boss	42	-433 146-1113 0		Spring
10	-175 019-1023 1		Side plate	43	-900 602-0000 4		Washer 4
11	-900 212-0501 2		Screw 5x12	44	-900 220-0401 0		Screw 4x10
12	175 310-1213 0		Plate	45	-433 137-1103 0		Nut
13	900 241-0401 0		Screw 4x10 w/SW	46	-433 114-1213 0		Spring
14	433 016-1103 0		Screw, adjustment	47	-433 115-1213 0		Washer
15	433 028-1103 0		Clip	48	-433 116-1103 0		Spacer
16	100 247-0283 0		Washer	49	-433 117-1103 0		Connector
17	433 014-0283 0		Tensioner	50	-433 113-1213 0		Stud bolt
18	433 011-1233 0		Stud bolt	51	-433 142-1103 0		Adjuster, brake band
19	433 013-1233 1		Side plate	52	<del>433 141-1103 0</del> 135 172-14730		Stud bolt
20	433 012-1233 1		Side plate	53	-433 122-1213 0		Spring
21	430 213-0033 0		Guide bar 24K50	54	-433 140-1103 0		Collar
22	431 013-1033 0		Chain 72LP-84E	55	-433 139-1213 0		Stud bolt
23	900 600-0000 5		Washer 5	56	-433 123-1213 0		Brake band
25	433 000-1283 0		Chain catcher	57	-433 312-1213 0		Cover, band brake
26	433 138-1213 0		Adapter	58	-433 135-1213 0		Seal
27	900 242-0501 4		Screw 4x14 w/W, SW	59	-433 314-1213 0		Seal
28	900 220-0502 5		Screw 5x25	60	-433 315-1213 0		Seal
<b>Options:</b>				61	-433 316-1213 0		Seal
**	<b>433 100-1213 0</b>		<b>Chain brake kit</b>	62	-433 022-0283 0		Locknut 5
30	-900 500-0000 5		Nut 5				
31	-900 605-0000 5		Spring washer 5				
32	-433 310-1213 0		Cover, brake				
33	-433 311-1213 0		Plate				

## Remarks:

- \* Consisting of 7 thru 11.
- \*\* Consisting of 30 thru 61
- \*\*\* Consisting of 40 thru 44.

(6) Carburetor

(7) Decal, Model plate and Tools

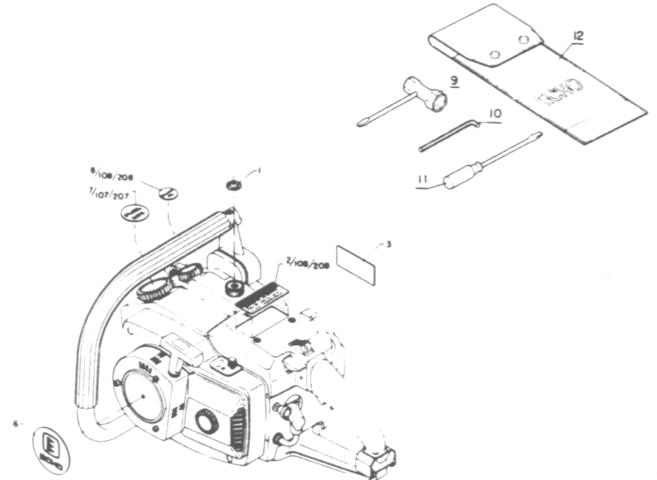
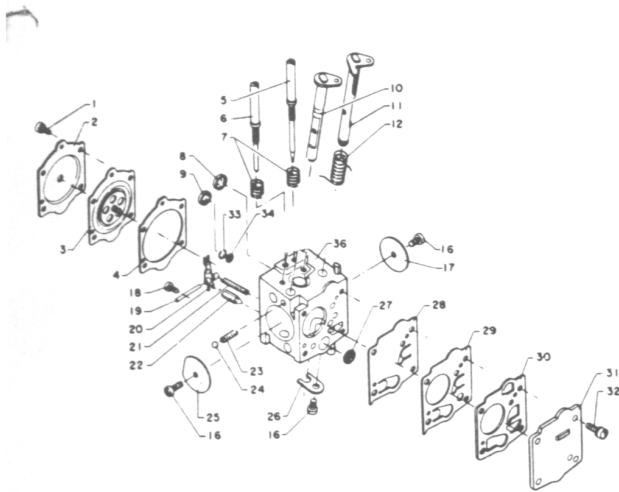

Key No.	Part No.	Q'ty	Description	Key No.	Part No.	Q'ty	Description
*	<b>123 000-1243 1</b>		<b>Carburetor ass'y</b>	7- 1	890 022-0343 0		Decal, oiler
1	-123 144-0393 0		Screw	2	890 151-1273 1		Decal, caution
2	-123 142-1243 0		Cover, metering diaphragm	3	890 021-0283 1		Decal, ECHO
3	-123 141-1243 0		Diaphragm, metering				
4	-123 140-1063 0		Gasket, metering diaphragm				
5	-123 118-1243 0		Needle, idle	6	890 112-1233 0		Decal, ECHO
6	-123 120-1243 0		Needle, high speed	7	890 147-1023 0		Decal, fuel mixer
7	-123 119-0393 0		Spring, needle	8	890 153-1063 0		Decal, chain oil
8	-123 145-1063 0		Plug, welch	*	<b>896 000-1243 0</b>		<b>Tool set</b>
9	-123 146-1063 0		Plug, welch	9	-895 410-0283 0		Box wrench w/s driver
10	-123 131-1243 0		Shaft ass'y, choke	10	-895 610-0013 0		L-wench, 4 mm
11	-123 117-1243 0		Shaft ass'y, throttle	11	-895 811-0013 0		Screw driver
12	-123 113-1243 0		Spring, throttle return	12	-898 510-0283 0		Tool bag
16	-123 114-1063 0		Screw				
17	-123 116-1063 0		Valve, throttle	<b>Francais:</b>			
18	-123 139-0393 0		Screw, metering lever pin	102	890 313-1273 1		Etiquette de securite
19	-123 138-1063 0		Pin, metering lever	107	890 315-1023 0		Etiquette de melange
20	-123 123-1063 0		Lever, metering	108	890 314-1063 0		Etiquette de huile pour chaine
21	-123 122-1063 0		Spring, metering lever	<b>Italiano:</b>			
22	-123 137-0393 0		Valve, inlet needle	202	890 513-1273 1		
23	-123 135-1063 1		Spring, choke friction	207	890 515-1023 0		
24	-123 136-1063 1		Ball, choke friction	208	890 514-1063 0		
25	-123 132-1063 0		Valve, choke				
26	-123 127-1063 1		Clip, throttle shaft				
27	-123 126-1063 0		Screen, inlet				
28	-123 112-1063 0		Diaphragm, fuel pump				
29	-123 111-1063 0		Diaphragm, check valve				
30	-123 125-1243 0		Gasket, fuel pump				
31	-123 124-1243 0		Cover, fuel pump				
32	-123 110-1063 0		Screw, pump cover				
33	-123 169-1063 0		Ring, retaining				
34	-123 168-1063 0		Screen				
36	-NOT AVAILABLE		Body ass'y, carburetor				

Remarks:  
\* Consisting of 9 thru 12.

Remarks:  
\* Consisting of 1 thru 12 and 16 thru 36.

**ECHO**®

**Motorgeräte**

*die geh'n ran*

