

ECHO

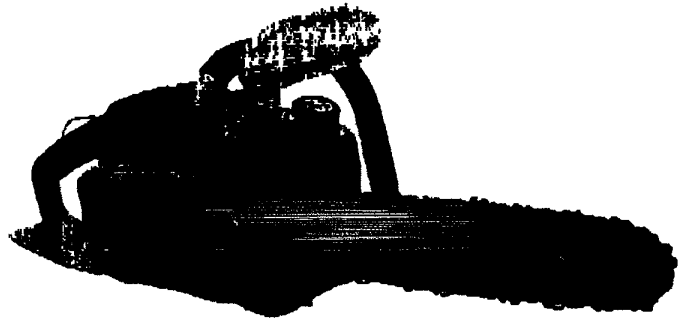

OPERATOR'S MANUAL

**ECHO
CHAIN SAW
CS-360EVL**

CAUTION

Read Rules for safe Operation
and Instructions Carefully

5

898 571-1883 0

CS-360EVL 1

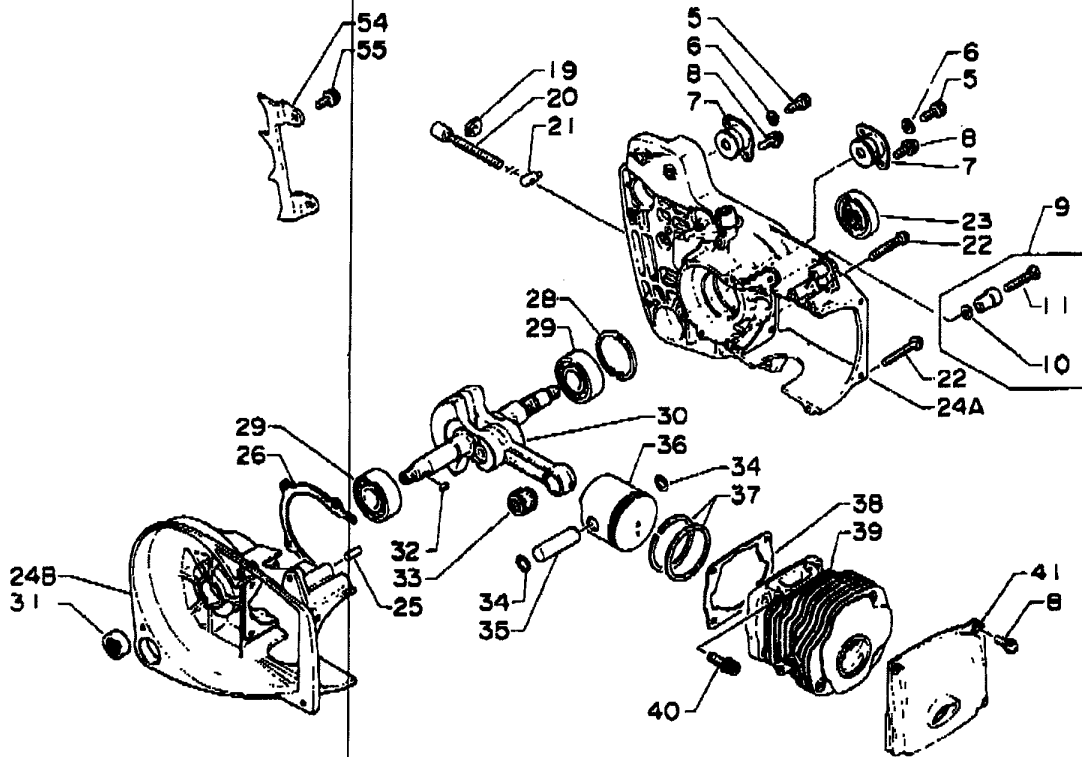

Key No.	Part number	Q'ty	Description	Key No.	Part number	Q'ty	Description
1- 5	900 106-0401 2	2	H.S.H. bolt 4x12	1-33	100 012-0072 0	1	Bearing, needle
6	900 805-0000 4	2	Lockwasher 4	34	100 015-0393 0	2	Circlip
7	100 921-1583 0	2	Cushion	35	100 013-0393 0	1	Pin, piston
8	900 242-0401 2	7	Screw 4x12	36	100 010-1653 0	1	Piston
9	433 000-1283 0	1	Catcher, chain	37	100 011-1333 0	2	Ring, piston
10	-900 600-0000 6	1	Washer 6	38	101 010-1513 0	1	Gasket
11	-900 220-0502 5	1	Screw 5x25	39	101 011-1653 0	1	Cylinder
19	433 028-1103 0	1	Clip	40	900 162-0502 0	4	H.S.H. bolt 5x20
20	433 018-1103 1	1	Screw, adjustment	41	101 514-1653 0	1	Cover, cylinder
21	433 014-0393 2	1	Tensioner	54	880 210-1513 0	1	Spike
22	900 242-0403 0	6	Screw 4x30	55	880 211-1513 0	2	Screw
23	100 213-0393 0	1	Oilseal				
24	100 200-1513 2	1	Crankcase set				
25	-100 215-0393 0	2	Knock				
26	100 242-1513 0	1	Gasket				
28	900 702-0003 2	1	Circlip				
29	900 810-0820 1	2	Bearing, ball				
30	100 100-1653 0	1	Crankshaft ass'y				
31	100 212-1123 0	1	Oilseal				
32	100 142-1233 0	1	Key, woodruff				

CS-360EVL 2

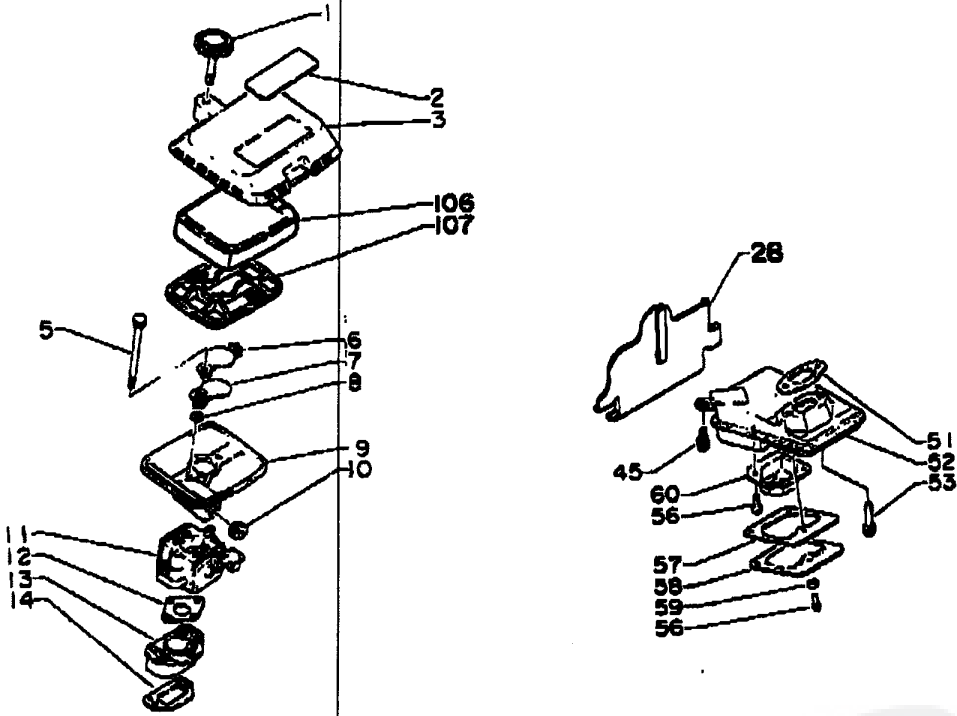

Key No.	Part number	Q'ty	Description	Key No.	Part number	Q'ty	Description
2-2	890 151-1883 0	1	Decal	2-45	900 162-0401 2	1	Screw
3	130 908-1663 0	1	Cover, air cleaner	51	145 510-0393 0	1	Gasket
1	-130 411-1383 0	1	Nut, thumb	52	145 605-1613 1	1	Muffler
5	130 021-0393 0	2	Bolt	53	900 108-0503 5	2	H.S.H. bolt
				56	900 220-0400 6	5	Screw 4 x 6
				57	145 866-1513 0	1	Gasket
6	129 011-1113 1	1	Plate	58	145 861-1513 0	1	Lid
7	178 815-1513 0	1	Shutter, choke	59	900 810-0000 4	3	Lock washer 4
8	178 516-1513 0	2	Spacer	80	145 814-1513 0	1	Adapter
9	130 314-1583 0	1	Body, air filter	106	130 351-1583 0	1	Silencer
10	178 810-0283 0	1	Grommet	107	130 310-1583 0	1	Air filter
11	123 000-1853 1	1	Carburetor				
12	130 016-0393 1	1	Gasket				
13	130 017-0393 1	1	Insulator				
14	130 010-0393 1	1	Gasket				
28	100 270-1863 0	1	Insulator				

CS-360EVL 3

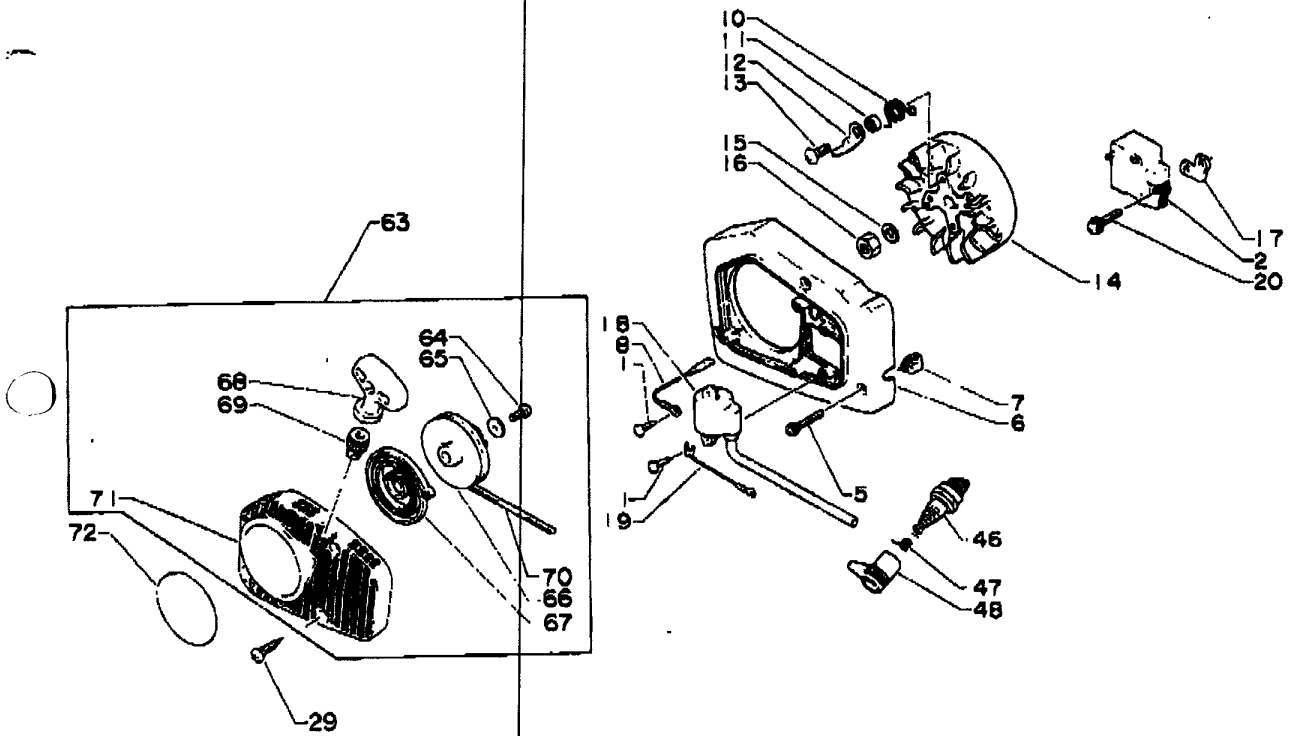

Key No.	Part number	Q'ty	Description	Key No.	Part number	Q'ty	Description
3-1	900 249-0401 6	2	Tapping screw	3-47	159 011-0343 2	1	Coil spring
2	156 601-1583 0	1	CDI module	48	159 012-0343 3	1	Cap. sparkplug
6	900 242-0403 0	3	Screw 4 x 30	63	177 200-1513 1	1	Recoil starter ass'y
6	101 511-1583 0	1	Fan cover	64	-900 242-0401 2	1	Screw 4 x 12
7	150 110-0151 0	1	Grommet	65	-177 214-0463 0	1	Washer
8	156 630-1583 0	1	Lead	66	-177 215-1513 3	1	Recoil drum
10	177 234-0393 1	2	Spring	67	-177 220-0653 0	1	Rewind spring
11	177 247-0393 2	2	Spacer	68	-177 228-0853 0	1	Grip
12	177 218-1513 0	2	Ratchet	69	-177 227-0533 0	1	Rope guide
13	177 217-1453 0	2	Screw	70	-177 228-0853 0	1	Rope
14	156 601-1583 0	1	Flywheel	71	-177 209-1513 0	1	Case
15	900 611-0000 8	1	Lock washer 8	72	890 112-1783 0	1	Decal
16	900 500-0000 8	1	Nut 8				
17	152 617-1513 0	1	Spacer				
18	166 626-1583 0	1	Ignition coil				
19	156 635-1583 0	1	Ground lead				
20	159 314-1513 0	2	Screw				
29	900 249-0401 6	3	Tapping screw				
46	159 010-1233 0	1	Spark plug BPM6A				

CS-360EVL 4

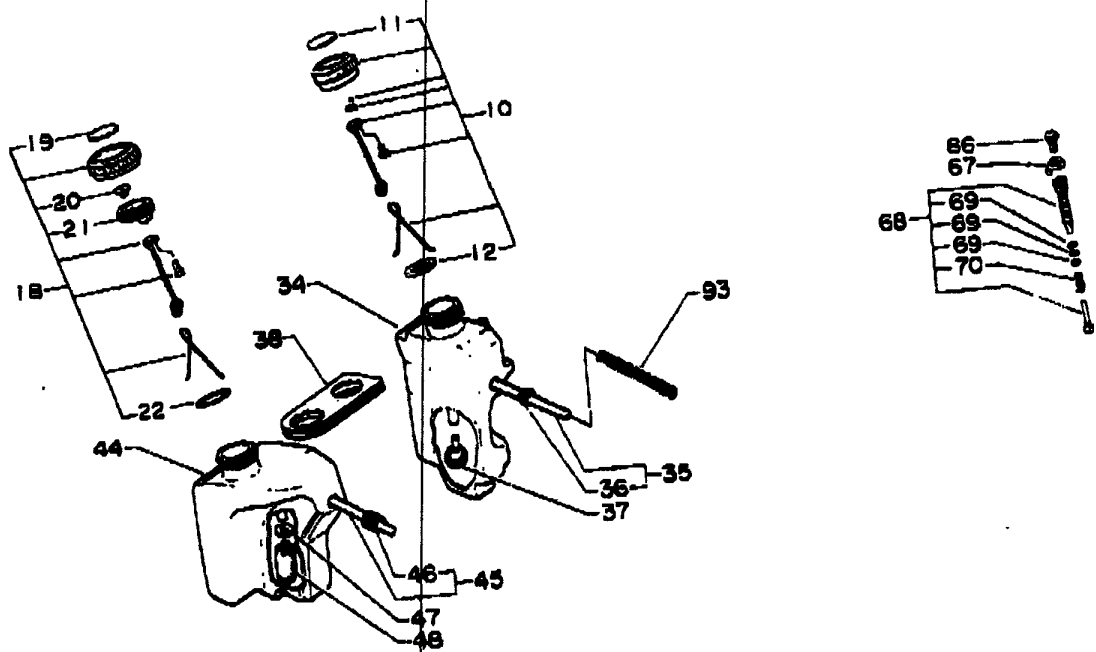

Key No.	Part number	Q'ty	Description	Key No.	Part number	Q'ty	Description
				4-46	-132 118-1233 0	1	Grommet
				47	900 603-0000 5	1	Washer
4-10	436 002-1453 0	1	Cap ass'y, oil	48	131 205-0083 0	1	Strainer, fuel
11	-890 153-1143 0	1	Decal	66	900 220-0501 0	1	Screw 5 x 10
12	-436 012-1233 0	1	Gasket	67	437 059-1113 3	1	Lock washer
18	131 600-1453 1	1	Cap ass'y, fuel				
19	-890 154-1513 0	1	Decal				
				68	437 000-0343 0	1	Auto filter ass'y
20	-131 314-0033 0	1	Check valve	69	-437 020-0283 0	3	O-ring
21	-131 015-1453 1	1	Holder	70	-437 019-0283 0	1	Spring
22	-900 720-0002 2	2	O-ring	93	437 412-1513 0	1	Coil spring
34	436 010-1513 0	1	Tank, oil				
35	437 205-1513 0	1	Pipe w/grommet				
36	-132 115-1113 0	1	Grommet				
37	436 205-1473 0	1	Strainer, oil				
38	131 038-1513 0	1	Connector				
44	131 010-1513 0	1	Tank, fuel				
45	437 205-1233 0	1	Pipe w/grommet				

CS-360EVL 6

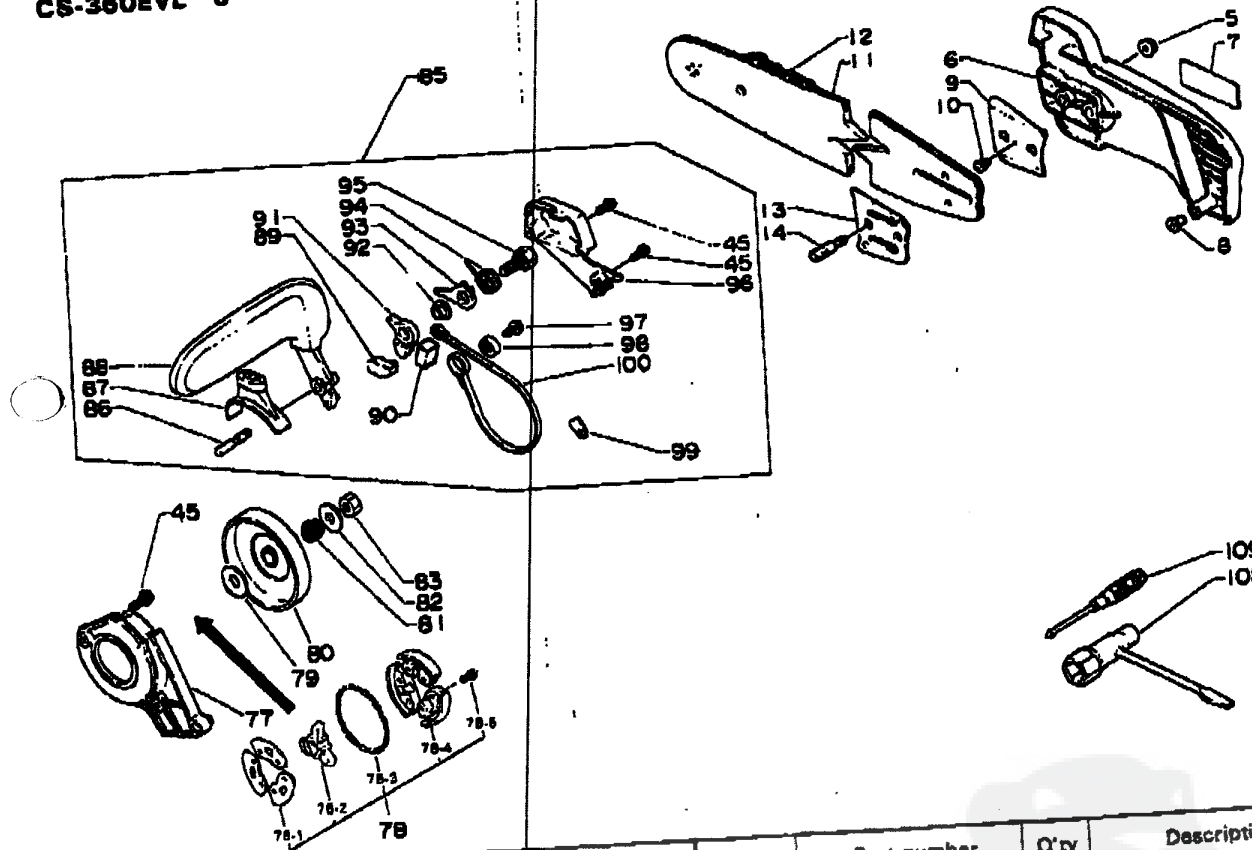

Key No.	Part number	Q'ty	Description	Key No.	Part number	Q'ty	Description
6-5	433 010-0393	3	Nut	6-86	-433 113-1233	0	1 Shaft
6	433 010-1853	0	Guard, sprocket	87	-433 312-1233	0	1 Cover
7	890 118-1833	0	Decal, ECHO	88	-433 108-1883	0	1 Handle
8	433 030-1483	0	Knock	89	-433 148-1483	0	1 Resat rubber
9	433 012-1453	2	Plate, outer	90	-433 313-1233	0	1 Seal
10	900 220-0300	6	Screw 3x6	91	-433 117-1233	0	1 Connector
11	430 219-1383	0	Guide bar 36RC50-3/8	92	-433 116-1233	0	1 Spacer
12	431 019-1513	0	Chain 918G-53E	93	-433 118-1233	0	1 Stopper
13	433 013-1453	1	Plate, inner	94	-433 114-1233	0	1 Spring
14	433 011-1453	0	Stud	95	-433 134-1233	0	1 Bolt
46	900 242-0401	2	Screw 4x12	96	-433 310-1513	0	1 Cover
77	175 310-1513	0	Seal plate	87	-900 241-0501	0	1 Adjuster
79	175 015-0393	0	Washer	98	-433 142-1233	0	1 Retainer
80	175 005-1583	0	Drum, clutch	99	-433 144-1513	0	1 Band, brake
81	175 012-0393	0	Bearing, needle	100	-433 123-1513	0	1
82	175 014-1153	0	Washer	108	895 410-0393	0	1 Wrench
83	100 138-0393	0	Lock nut	109	895 812-0393	0	1 Driver
85	433 100-1883	0	Brake ass'y, chain	78	175 000-0393	1	1 Clutch ass'y
45	-900 242-0401	2	Screw 4x12	78-1	-175 018-1983	0	3 Plate
				78-2	-175 016-1453	1	1 Hub, clutch
				78-3	-175 018-1983	0	1 Spring, clutch
				78-4	-175 002-1983	0	1 Shoe kit, clutch
				78-5	-900 281-0400	8	6 Screw

CS-360EVL 7

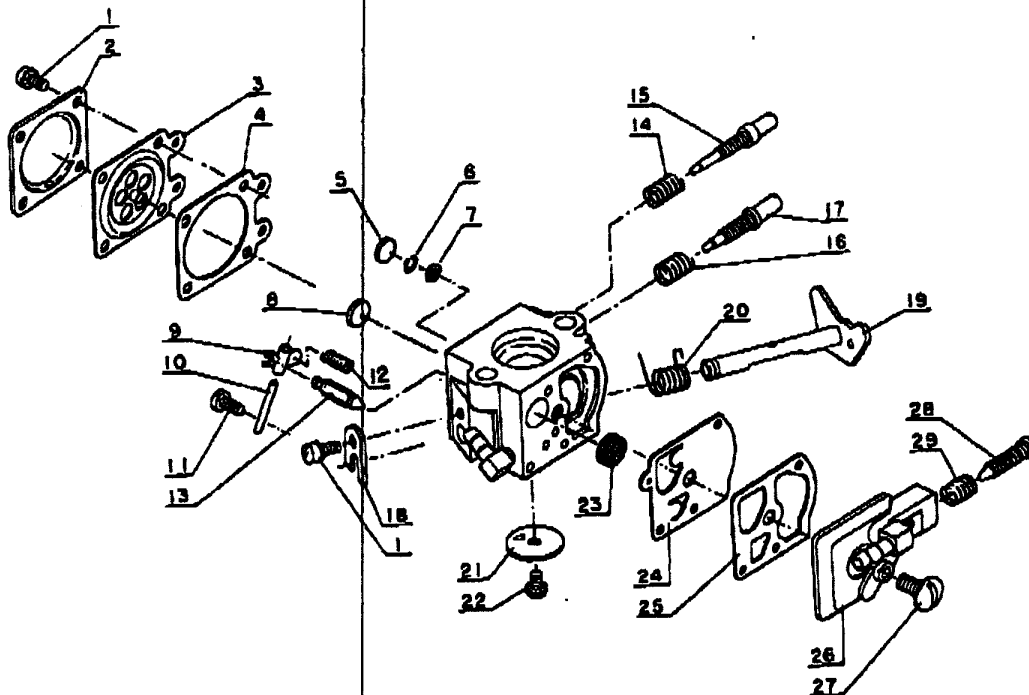

Key No.	Part number	Q'ty	Description	Key No.	Part number	Q'ty	Description
7.	123 000-1653	1	Carburetor (WA-137)	7-15	-123 120-1653	0	1 Needle, high speed
1	-123 130-0286	0	5 Screw	16	-123 121-0393	0	1 Spring, needle
2	-123 142-0393	0	1 Cover, m. Diaphragm	17	-123 118-1653	0	1 Needle, idle
3	-123 141-0393	0	1 Diaphragm, metering	18	-123 127-0393	0	1 Clip, throttle shaft
4	-123 140-0393	0	1 Gasket, m. Diaphragm	19	-123 117-1453	0	1 Shaft, throttle
5	-123 146-1633	0	1 Plug, Welch	20	-123 113-0393	0	1 Spring, thrt. Return
6	-123 169-1063	0	1 Ring, retaining	21	-123 116-1053	0	1 Valve, throttle
7	-123 188-1063	1	1 Screen	22	-123 114-0393	0	1 Screw, thrt. Valve
8	-123 146-1063	0	1 Plug, Welch	23	-123 126-1063	1	1 Screen, inlet
9	-123 123-0393	0	1 Lever, metering	24	-123 112-1503	0	1 Diaphragm, fuel pump
10	-123 138-0393	0	1 Pin, metering lever	25	-123 125-1603	0	1 Gasket, fuel pump
11	-123 139-0393	0	1 Screw, m. Lever pin	26	-123 124-1653	0	1 Cover, fuel pump
12	-123 122-0653	0	1 Spring, meter. Lever	27	-123 110-0393	0	1 Screw, pump cover
13	-123 137-0393	0	1 Valve, inlet needle	28	-123 134-1113	0	1 Screw, idle adjust
14	-123 119-0393	0	1 Spring, needle	29	-123 133-1113	0	1 Spring, idle adjust