

SRM-3610T/U

Published:01/23/2018

TABLE OF CONTENTS

CYLINDER, PISTON, CRANKSHAFT.....	1
VALVE, CAM.....	3
MAGNETO.....	5
CLUTCH.....	7
AIR CLEANER, CARBURETOR.....	9
CARBURETOR.....	11
FUEL TANK.....	13
MUFFLER.....	15
RECOIL STARTER, PULLY.....	17
GEAR CASE, SHIELD.....	19
MAIN PIPE, HANDLE.....	21
THROTTLE.....	23
ACCESSORIES.....	25
NYLON LINE CUTTER.....	27

CYLINDER, PISTON, CRANKSHAFT

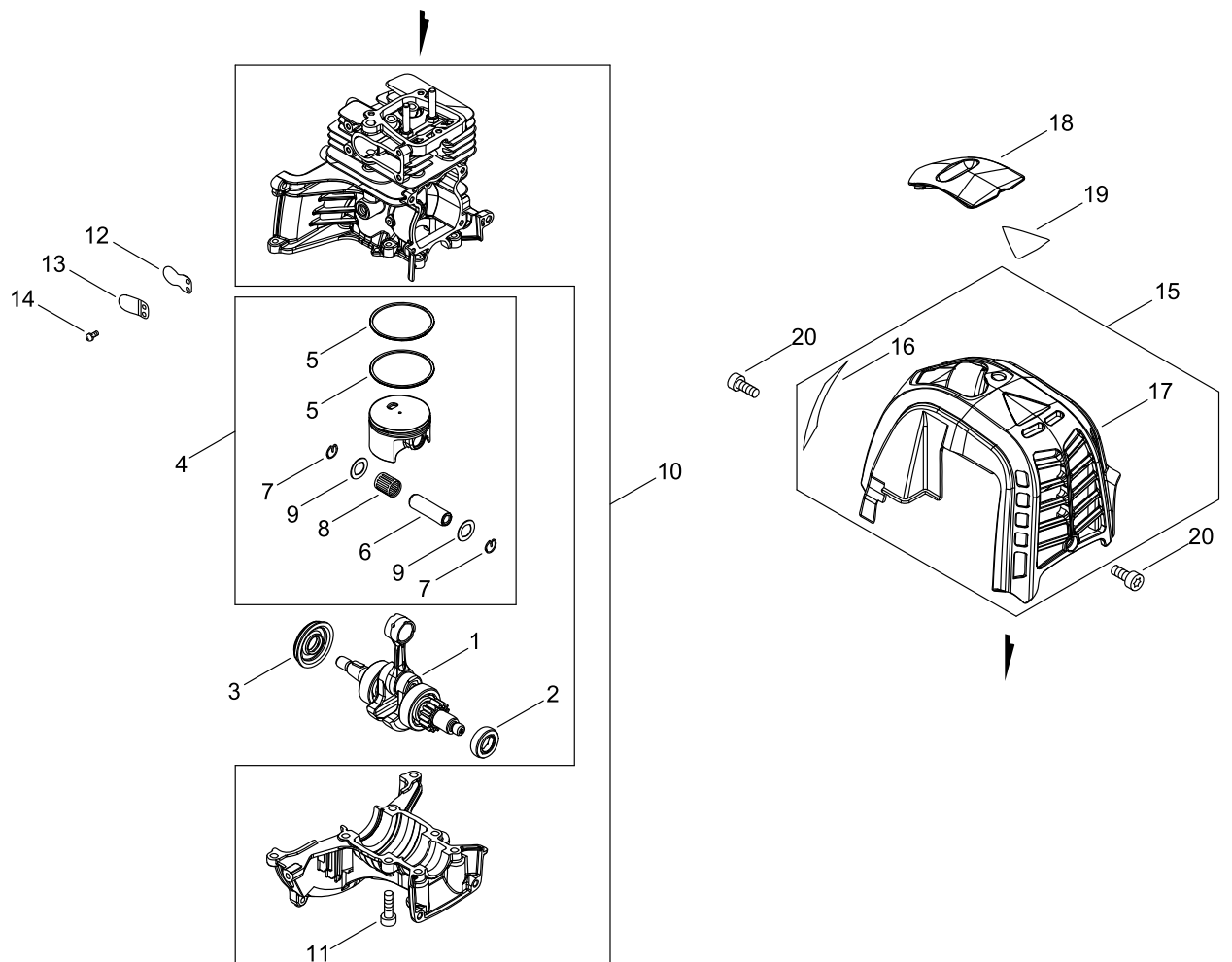

CYLINDER, PISTON, CRANKSHAFT

KEY NO	LV(+)	Part No	Description	Qty	Standard	Comment
1		A011-001530	CRANKSHAFT,ASY	1		
2		V505-000020	SEAL,OIL 12	1	12*22*7	
3		V505-000011	SEAL,OIL 12	1	12*32*5.5	
4		P100-004740	PISTON KIT	1		
5	+	A101-000730	RING, PISTON	2		
6	+	V608-000000	PIN,ENG 10	1		
7	+	V580-000010	RING,END	2	10	
8	+	V555-000010	BEARING,NEEDLE 10	1		
9	+	V307-000580	WASHER,CIRCULAR 10	2		
10		P100-004730	CYL. CRANKCASE SET	1		
11	+	V805-000250	BOLT, TORX 5	8	TB-5*16 12.9	
12		A211-000021	VALVE, REED	1		
13		A212-000021	GUIDE, VALVE	1		
14		91341-03006	SCREW SW	2		
15		A160-003390	COVER,CYLINDER	1		
16	+	X502-000390	LABEL,ECHO	1	ECHO 72.5*15	
17	+	A160-003410	COVER,CYLINDER	1		
18		A429-000220	COVER,CAP	1		
19		X530-000590	LABEL,EYE CATCHER	1		
20		V805-000140	BOLT, TORX 5	3	TB-5*12 10.9	

VALVE, CAM

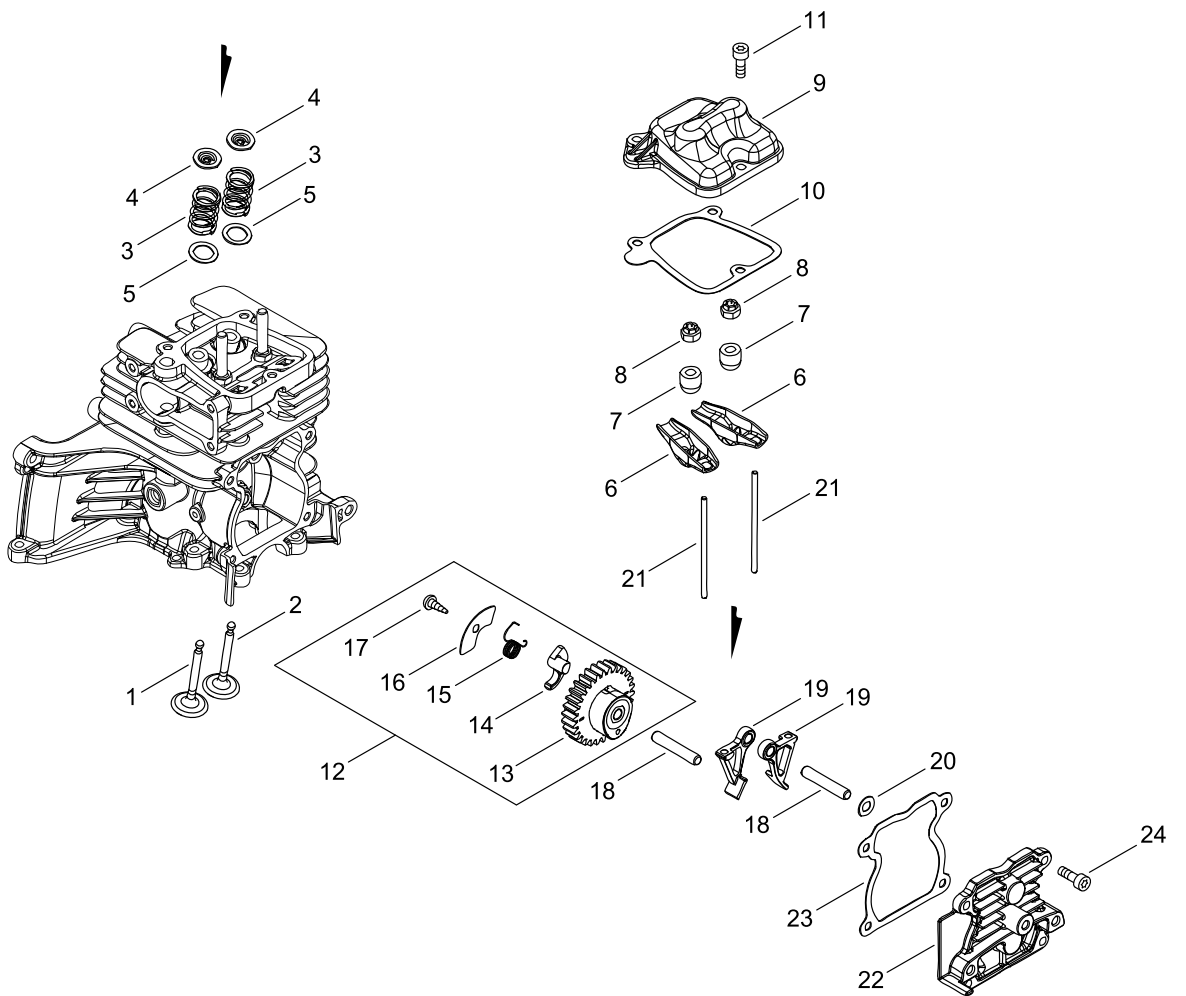

VALVE, CAM

KEY NO	LV(+)	Part No	Description	Qty	Standard	Comment
1		A603-000090	VALVE	1		
2		A603-000100	VALVE	1		
3		A604-000030	SPRING,VALVE	2		
4		A606-000040	RETAINER	2		
5		V392-000030	PLATE	2		
6		A610-000090	ARM,ROCKER	2		
7		V353-000720	COLLAR,5	2		
8		V263-000500	NUT,5	2	M5X0.8	
9		A137-000040	COVER,ROCKER ARM	1		
10		V109-000340	GASKET	1		
11		V804-000040	BOLT, TORX 4	3	TB-4*10 10.9	
12		P100-004750	CAM GEAR ASY	1		
13	+	A622-000020	GEAR,CAM	1		
14	+	A146-000020	WEIGHT,DECOMP	1		
15	+	V452-001800	SPRING,TORSION	1		
16	+	C603-000240	PLATE	1		
17	+	V252-000930	SCREW,4	1	4XL6	
18		900330-50280	ROLLER	2		
19		A600-000020	LIFTER	2		
20		V303-000220	WASHER	1	T0.3	
21		A607-000030	ROD,PUSH	2		
22		P100-004760	COVER,CAM GEAR	1		
23		V109-000040	GASKET	1		
24		V804-000050	BOLT, TORX 4	4	TB-4*12 10.9	

MAGNETO

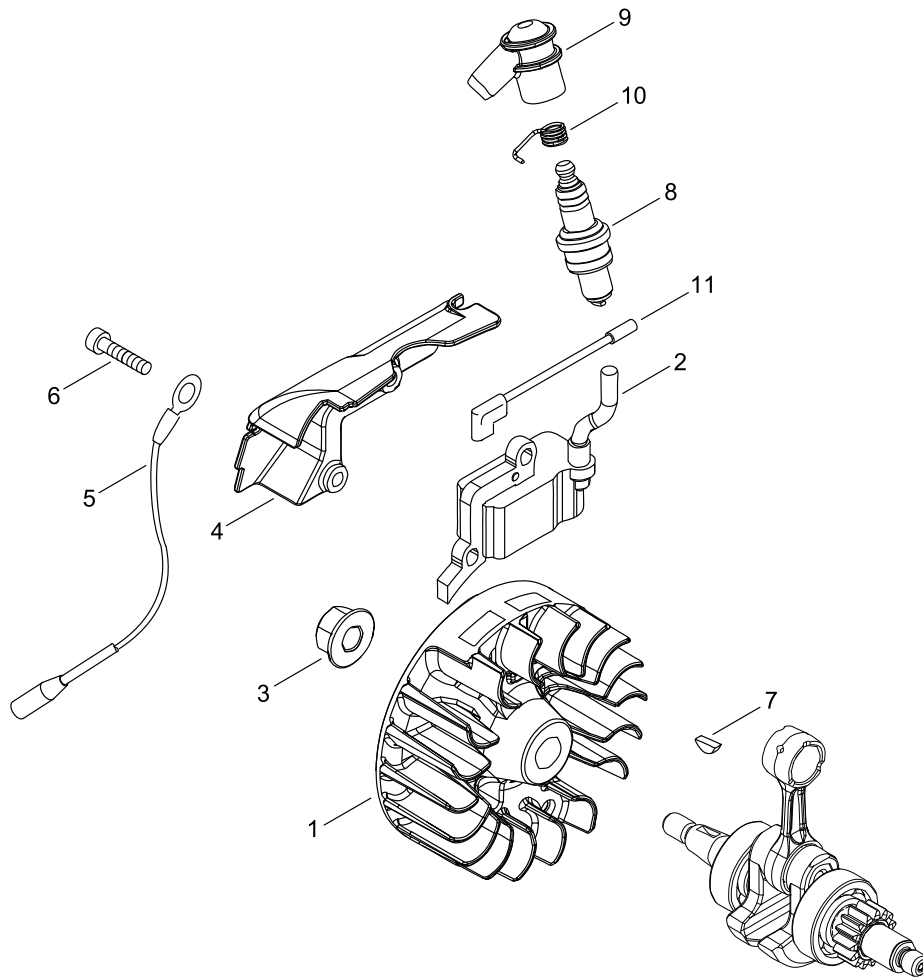

MAGNETO

KEY NO	LV(+)	Part No	Description	Qty	Standard	Comment
1		A409-001340	ROTOR, MAGNETO	1		
2		A411-001770	COIL, IGNITION	1		
3		900515-00008	NUT, FLANGE 8	1	8	
4		E106-000240	GUIDE,AIR	1		
5		V485-003020	LEAD	1		
6		V203-002400	BOLT,5	2		
7		93115-03010	KEY	1	3*10	
8		A425-000040	SPARKPLUG	1	NGK CMR5H	
9		A427-000190	CAP,SPARK PLUG	1		
10		A426-000010	TERMINAL,SPARKPLUG	1		
11		V485-003010	LEAD	1		

CLUTCH

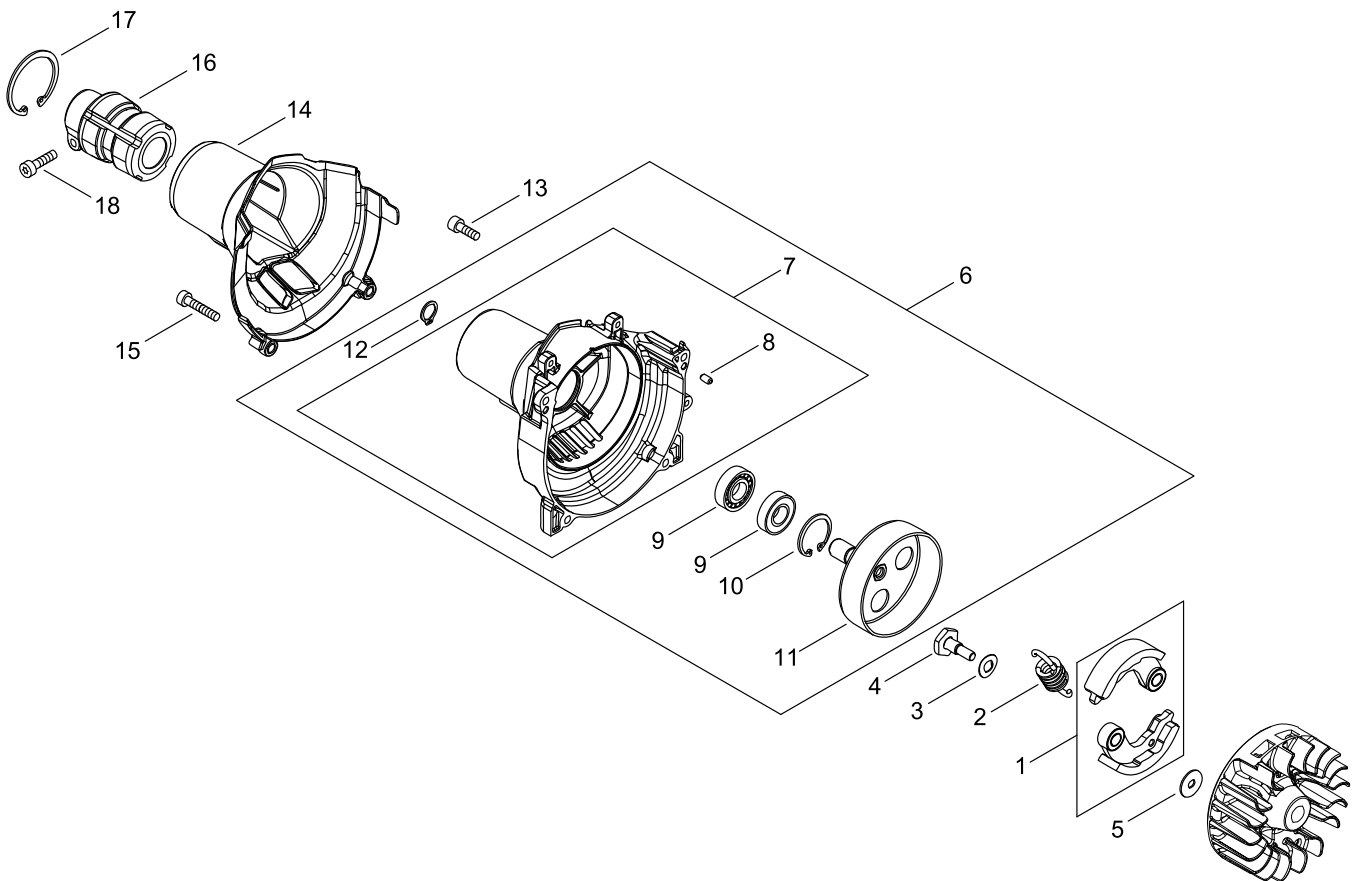

CLUTCH

KEY NO	LV(+)	Part No	Description	Qty	Standard	Comment
1		P021-046970	CLUTCH SHOE SET	1		
2		A566-000320	SPRING, CLUTCH	1		
3		175049-56030	WASHER	2	8.5*16*0.5	
4		A557-000150	SHAFT, CLUTCH	2		
5		175048-05530	WASHER (I)	2	6.2*19*1.0	
6		P100-004780	COVER ASY, FAN	1		
7	+	A172-003350	COVER,FAN	1		
8	++	900330-40080	PIN F 4*8	2	4*8	
9	+	94018-46001	BEARING, BALL	2		
10	+	92419-28000	C-RING	1		
11	+	A556-001810	DRUM, CLUTCH	1		
12	+	900701-00012	CIRCLIP 12	1	CS-12	
13		V805-000150	BOLT, TORX 5	2	TB-5*16 10.9	
14		A413-000100	BOOT	1		
15		V805-000170	BOLT, TORX 5	2	TB-5*25 10.9	
16		A575-000640	FIXTURE, MAIN PIPE	1		
17		92424-42000	SNAP RING	1	42MM C-RING	
18		V805-000170	BOLT, TORX 5	1	TB-5*25 10.9	

AIR CLEANER, CARBURETOR

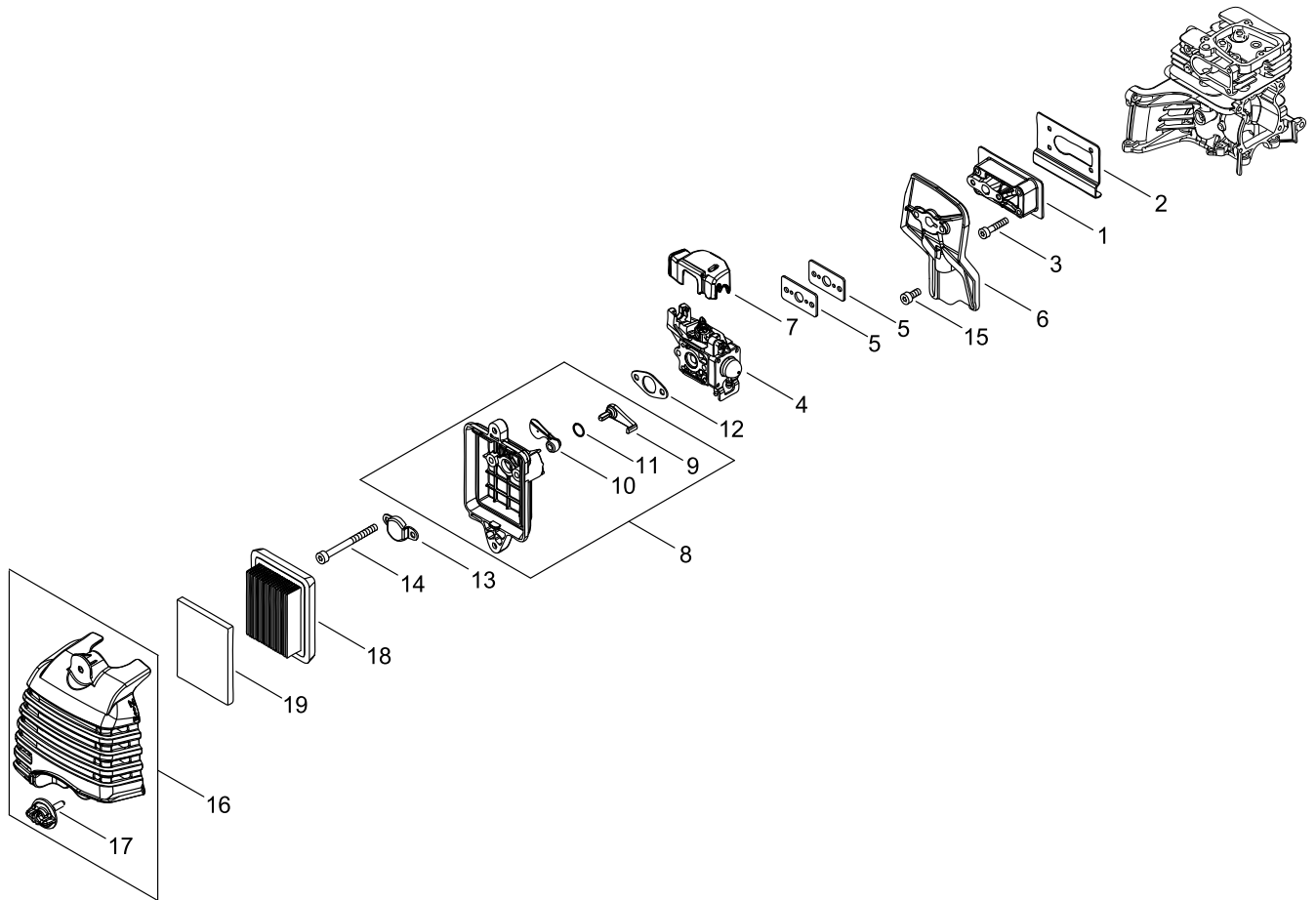

AIR CLEANER, CARBURETOR

KEY NO	LV(+)	Part No	Description	Qty	Standard	Comment
1		A200-001190	INSULATOR, INTAKE	1		
2		V103-001980	GASKET,INTAKE	1		
3		V804-000120	BOLT, TORX 4	4		
4		A021-004820	CARBURETOR, DIAPHRAGM	1		
5		V103-001990	GASKET,INTAKE	2		
6		A209-001070	PLATE, INSULATOR	1		
7		A127-000440	COVER,DUST	1		
8		A023-000360	CASE,CLEANER	1		
9	+	A242-000280	LEVER, CHOKE	1		
10	+	A243-000380	SHUTTER, CHOKE	1		
11	+	V581-000790	RING,O	1		
12		V103-001970	GASKET,INTAKE	1		
13		A244-000330	PLATE, PREVENT	1		
14		V805-000100	BOLT, TORX 5	2	TB-5*65 10.9	
15		V805-000140	BOLT, TORX 5	1	TB-5*12 10.9	
16		P100-004790	CLEANER COVER ASY	1		
17	+	A235-000450	KNOB,CLEANER LID	2		
18		A226-000361	ELEMENT, AIR FILTER	1	AFP-2010K-300	
19		A226-002200	ELEMENT, AIR FILTER	1		

CARBURETOR

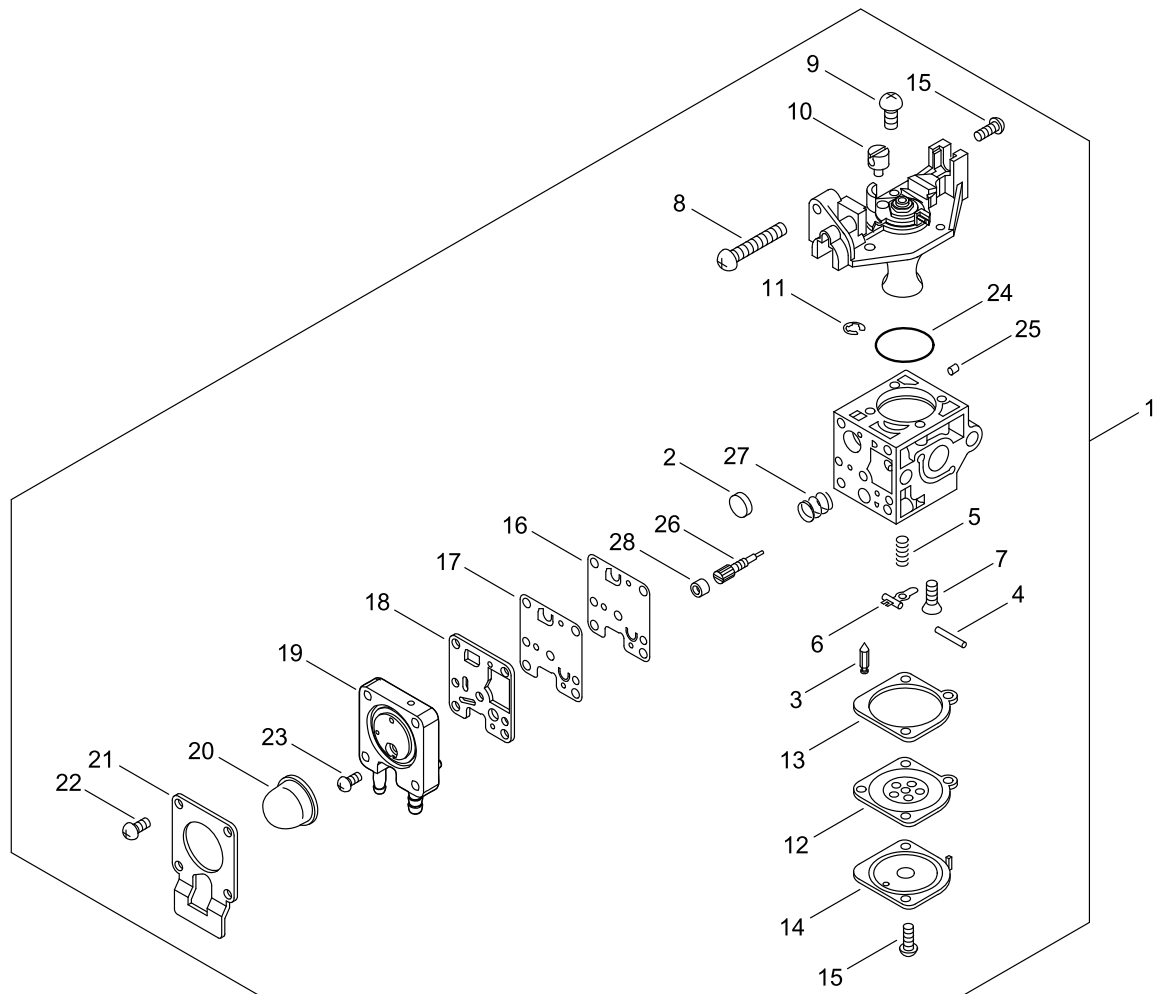

CARBURETOR

KEY NO	LV(+)	Part No	Description	Qty	Standard	Comment
1		A021-004820	CARBURETOR, DIAPHRAGM	1		
2	+	P005-000010	STRAINER	1		
3	+	125337-08260	VALVE, INLET NEEDLE	1		
4	+	125338-13930	PIN, METERING ARM	1		
5	+	125322-13930	SPRING, COIL	1		
6	+	125323-08260	ARM, VALVE	1		
7	+	125339-42030	SCREW	1		
8	+	P005-000100	SCREW, THROTTLEADJUST	1		
9	+	125344-13931	SCREW	3		
10	+	P005-001240	POST	1		
11	+	P005-000190	E-RING	1		
12	+	P005-003760	DIAPHRAGM ,METERING	1		
13	+	P005-000200	GASKET, METERING	1		
14	+	125342-52130	COVER, DIAPHRAGM	1		
15	+	125344-52130	SCREW	3		
16	+	P005-003930	DIAPHRAGM, PUMP	1		
17	+	P005-003940	DIAPHRAGM, PUMP	1		
18	+	P005-000520	GASKET, PUMP	1		
19	+	P005-004240	BASE, ASY PRIMER	1		
20	+	P005-003110	PUMP, PRIMER	1		
21	+	P005-000250	RETAINER	1		
22	+	P005-001900	SCREW	4		
23	+	P005-000270	SCREW	1		
24	+	P005-000280	O-RING	1		
25	+	P005-001000	ROLLER, GUIDE	1		
26	+	P005-003950	SCREW,MAIN MIXTURE	1		
27	+	P005-003960	SPRING, PUMP	1		
28	+	P005-001270	PLUG, H AJUST SCREW	1		

FUEL TANK

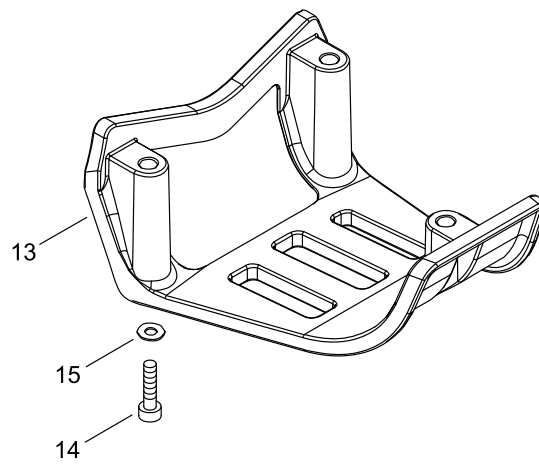
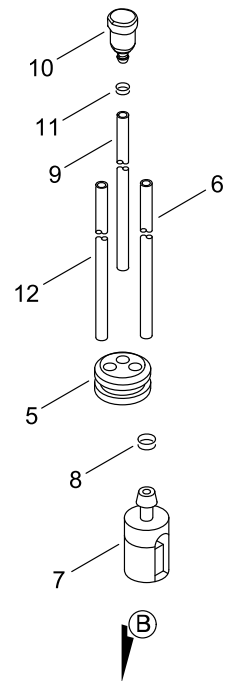
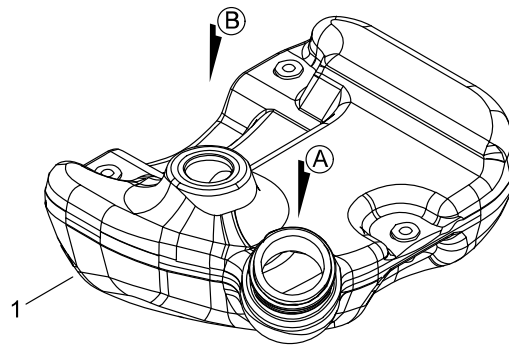
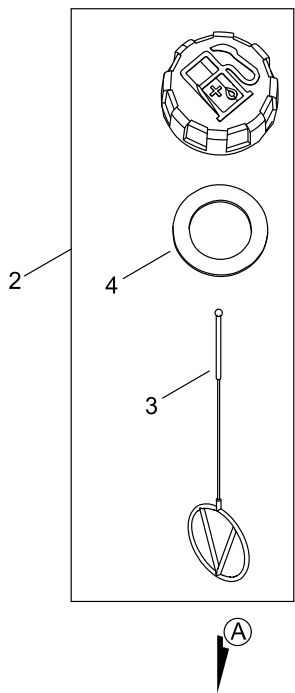

FUEL TANK

KEY NO	LV(+)	Part No	Description	Qty	Standard	Comment
1		A350-002460	TANK, FUEL	1		
2		P021-012210	CAP,FUEL ASY	1		
3	+	A365-000060	CONNECTOR,CAP	1	L=123	
4	+	131016-55830	GASKET, FUEL CAP	1		
5		132115-55930	GROMMET, FUEL	1		
6		V471-004170	PIPE	1	3*5*235	
7		A369-000420	STRAINER, FUEL	1	ES-16499	
8		V490-000500	CLIP	1		
9		V471-001500	PIPE	1	3*6*80	
10		A356-000050	VALVE,CHECK	1		
11		V490-000500	CLIP	1		
12		V471-005290	PIPE	1		
13		A175-000390	STAND	1		
14		V805-000170	BOLT, TORX 5	3	TB-5*25 10.9	
15		900603-00005	WASHER 5	3	5.5*12*0.8	

MUFFLER

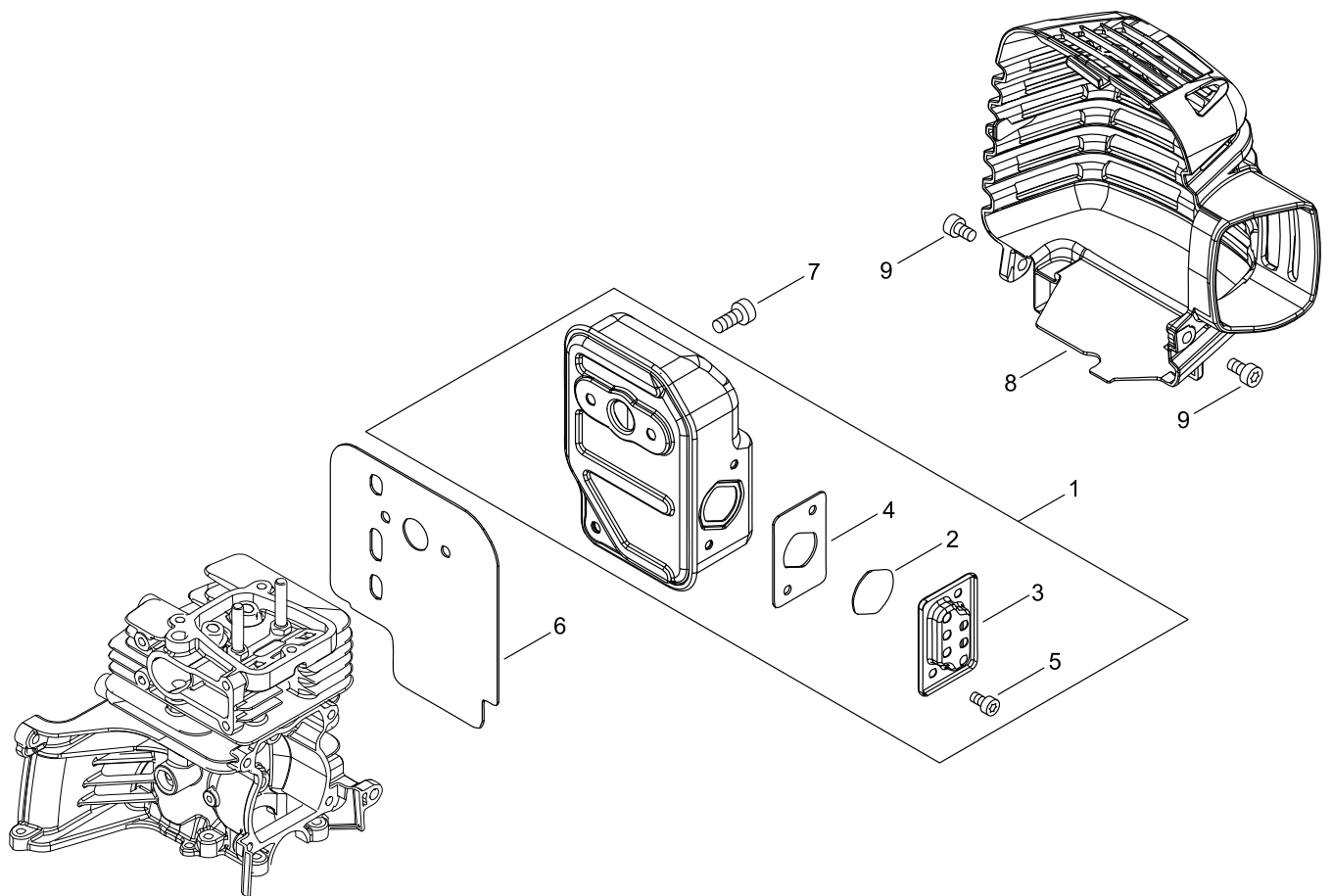

MUFFLER

KEY NO	LV(+)	Part No	Description	Qty	Standard	Comment
1		P100-004810	MUFFLER ASY	1		
2	+	A310-000520	SCREEN, ARRESTOR	1		
3	+	A313-002070	GUIDE, EXHAUST	1		
4	+	V104-002360	GASKET,EXHAUST	1		
5	+	V804-000030	BOLT, TORX 4	2	TB-4*8 10.9	
6		V104-002370	GASKET,EXHAUST	1		
7		V805-000250	BOLT, TORX 5	3	TB-5*16 12.9	
8		A320-001280	COVER,MUFFLER	1		
9		V805-000140	BOLT, TORX 5	2	TB-5*12 10.9	

RECOIL STARTER, PULLY

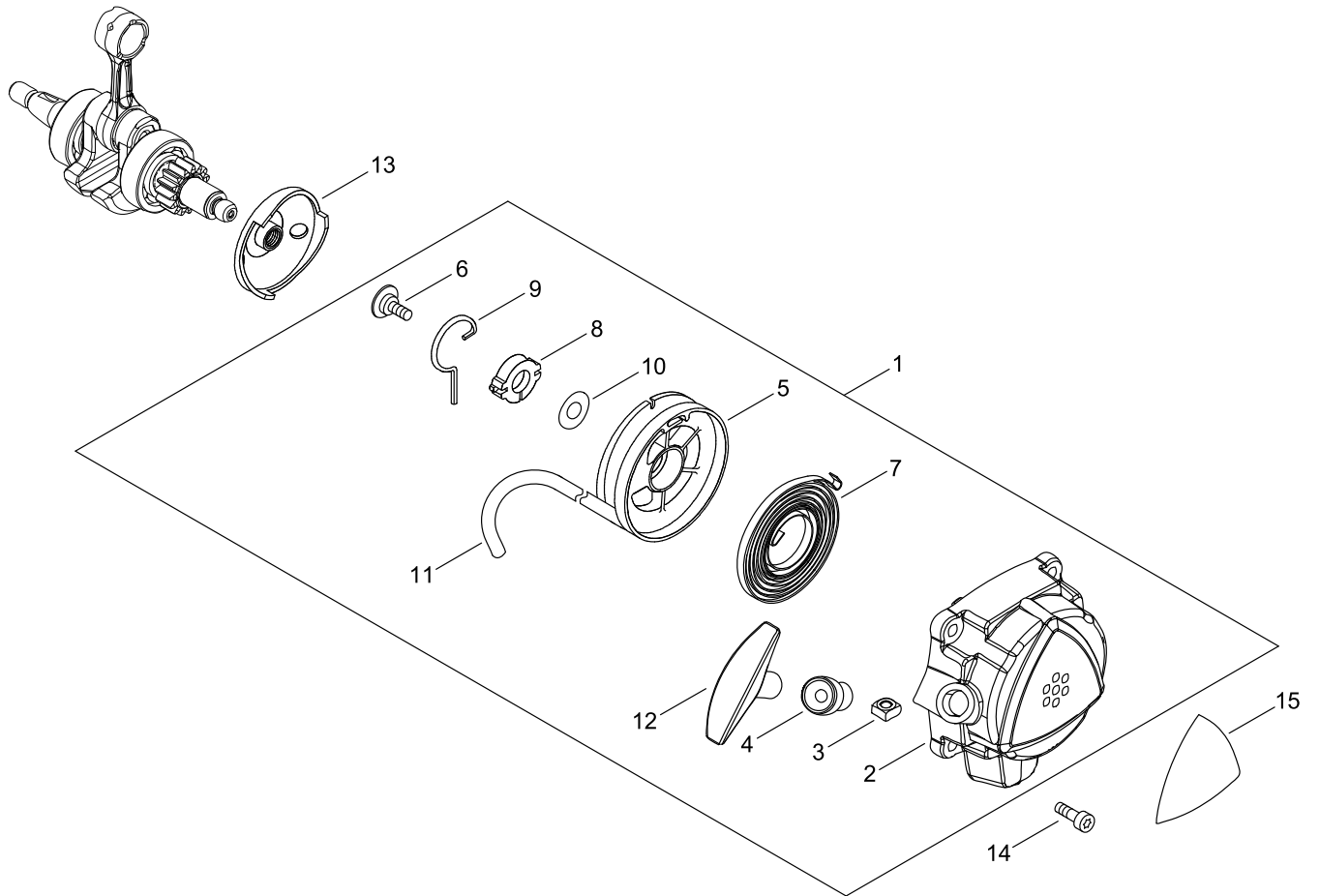

RECOIL STARTER, PULLY

KEY NO	LV(+)	Part No	Description	Qty	Standard	Comment
1		A051-003330	STARTER,RECOIL ASY	1		
2	+	P022-049760	CASE, STARTER	1		
3	+	P022-022010	NUT	1		
4	+	P022-045770	GUIDE, ROPE	1		
5	+	P022-049770	DRUM, STARTER	1		
6	+	177236-61830	SCREW	1		
7	+	177220-42030	SPRING, REWIND	1		
8	+	P022-049780	COLLAR	1		
9	+	P022-049790	SWING ARM	1		
10	+	177214-41030	WASHER	1		
11	+	P022-049800	ROPE, STARTER	1		
12	+	177228-44330	GRIP, STARTER	1		
13		A052-000300	STARTER PULLEY	1		
14		V805-000140	BOLT, TORX 5	4	TB-5*12 10.9	
15		X547-003280	LABEL,ECHO	1		

GEAR CASE, SHIELD

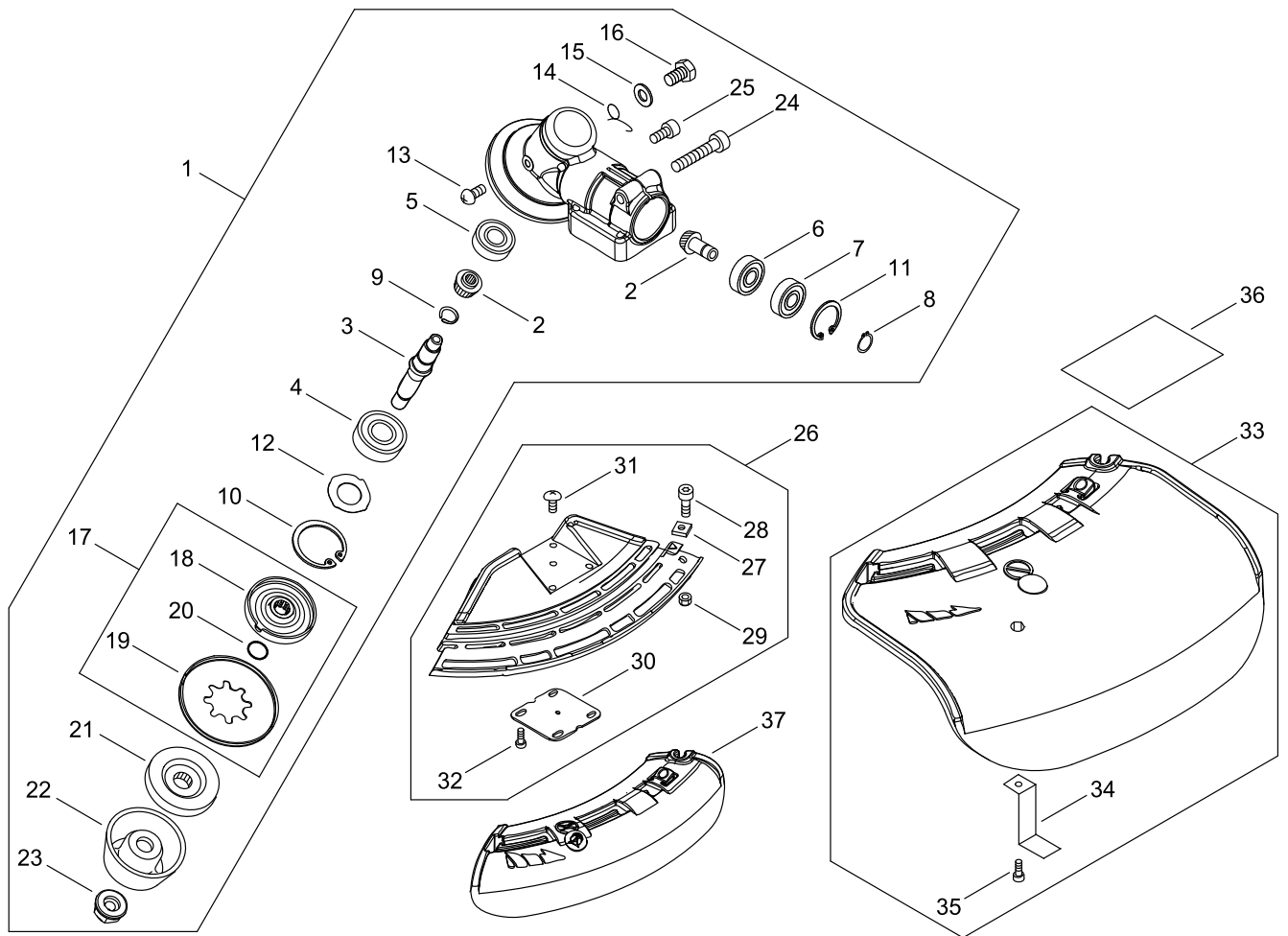

GEAR CASE, SHIELD

KEY NO	LV(+)	Part No	Description	Qty	Standard	Comment
1		P100-004840	CASE,GEAR ASY	1		
2	+	V000-000260	GEAR SET, BEVEL	1		
3	+	C534-001080	SHAFT, GEAR	1		
4	+	900812-06201	BEARING, BALL 6201	1	6201DDU(LLU)	
5	+	900810-00629	BEARING, BALL 629	1	629	
6	+	900800-00609	BEARING, BALL 609	1	609	
7	+	900803-00609	BEARING, BALL 609	1	609Z	
8	+	900701-00009	CIRCLIP 9	1	CS-9	
9	+	900706-00012	CIRCLIP 12	1	WR-12	
10	+	900702-00032	CIRCLIP 32	1	CR-32	
11	+	900702-00025	CIRCLIP 25	1	CR-25	
12	+	V340-000180	WASHER	1		
13	+	900220-04006	SCREW 4*6	1	4*6	
14	+	V452-001310	SPRING,TORSION	1		
15	+	900603-50008	WASHER	1	8.5*18*0.8T	
16	+	610434-50031	BOLT 8* 8	1	M8*8	
17	+	610313-52932	FIXTURE,BLADE	1		
18	++	610313-52132	FIXTURE,BLADE	1		
19	++	610352-56830	PLATE, CUP	1		
20	++	900720-00012	O-RING 12	1	P-12	
21	+	610314-52130	PLATE, ADAPTER (L)	1		
22	+	699229-56830	PLATE, COVER	1		
23	+	610320-52130	NUT 10	1		
24	+	V806-000020	BOLT, TORX 6	1	TB-6*25 10.9	
25	+	V805-000130	BOLT, TORX 5	1	TB-5*10 10.9	
26		P021-050810	SHIELD BLADE ASY	1		
27	+	900565-00005	NUT	1	5	
28	+	V805-000170	BOLT, TORX 5	1	TB-5*25 10.9	
29	+	900562-00005	NUT, LOCK	1	5	
30	+	C552-000200	PLATE, SHIELD	1		
31	+	91316-04010	SCREW	1	M4*10	
32	+	V805-000260	BOLT, TORX 5	4	TB5*25 10.9	
33		P021-043981	SHIELD ASY, BLADE	1		
34	+	C554-000001	KNIFE,CORD	1		
35	+	V805-000150	BOLT, TORX 5	1	TB-5*16 10.9	
36		X530-000560	LABEL,EYE CATCHER	1	HIGH TORQUE	
37		C550-000541	SHIELD, BLADE	1		

MAIN PIPE, HANDLE

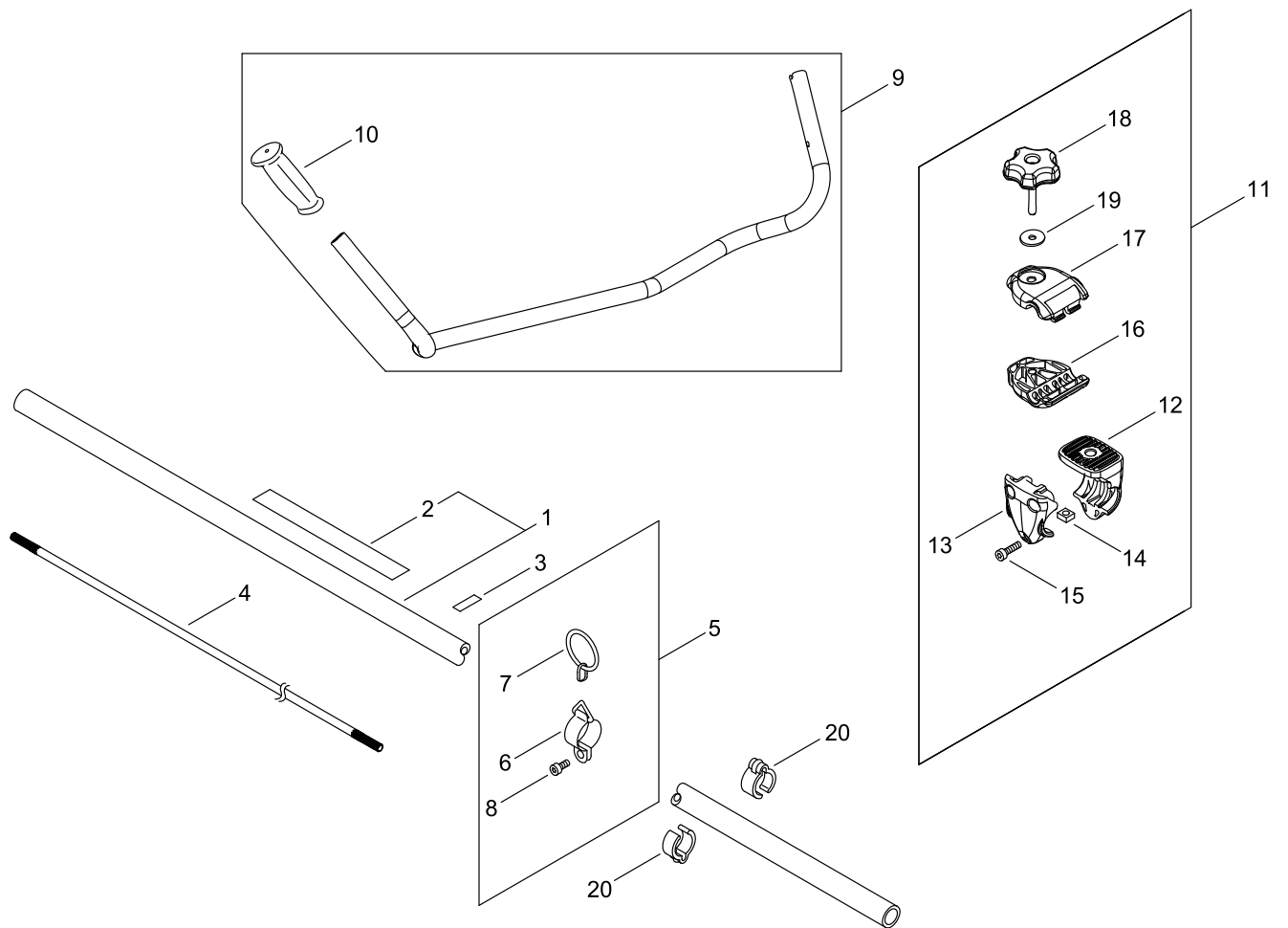

MAIN PIPE, HANDLE

KEY NO	LV(+)	Part No	Description	Qty	Standard	Comment
1		P021-049000	MAIN PIPE ASY	1		
2	+	890617-43130	LABEL,CAUTION	1		
3		890152-04930	LABEL, CAUTION	1		
4		610011-25530	SHAFT, DRIVE	1		
5		P021-016221	HOOK ASS'Y	1		
6	+	301205-21331	HOOK	1		
7	+	301015-05330	HOOK, BAND	1		
8	+	V805-000140	BOLT, TORX 5	1	TB-5*12 10.9	
9		P100-003860	HANDLE ASY	1		
10	+	C403-000031	GRIP,HANDLE	1		
11		P021-016232	FIXTURE,ASY HANDLE	1		
12	+	351312-52131	BRACKET, HANDLE (U)	1		
13	+	351313-52130	BRACKET, HANDLE (C)	1		
14	+	900565-50008	NUT	1	8*1.25	
15	+	V805-000170	BOLT, TORX 5	3	TB-5*25 10.9	
16	+	C423-000043	FIXTURE,HANDLE	1		
17	+	C423-000030	FIXTURE,HANDLE	1		
18	+	V299-000110	KNOB,FASTENER	1		
19	+	605014-54230	WASHER	1		
20		224924-52130	CLIP	2	25MM	

THROTTLE

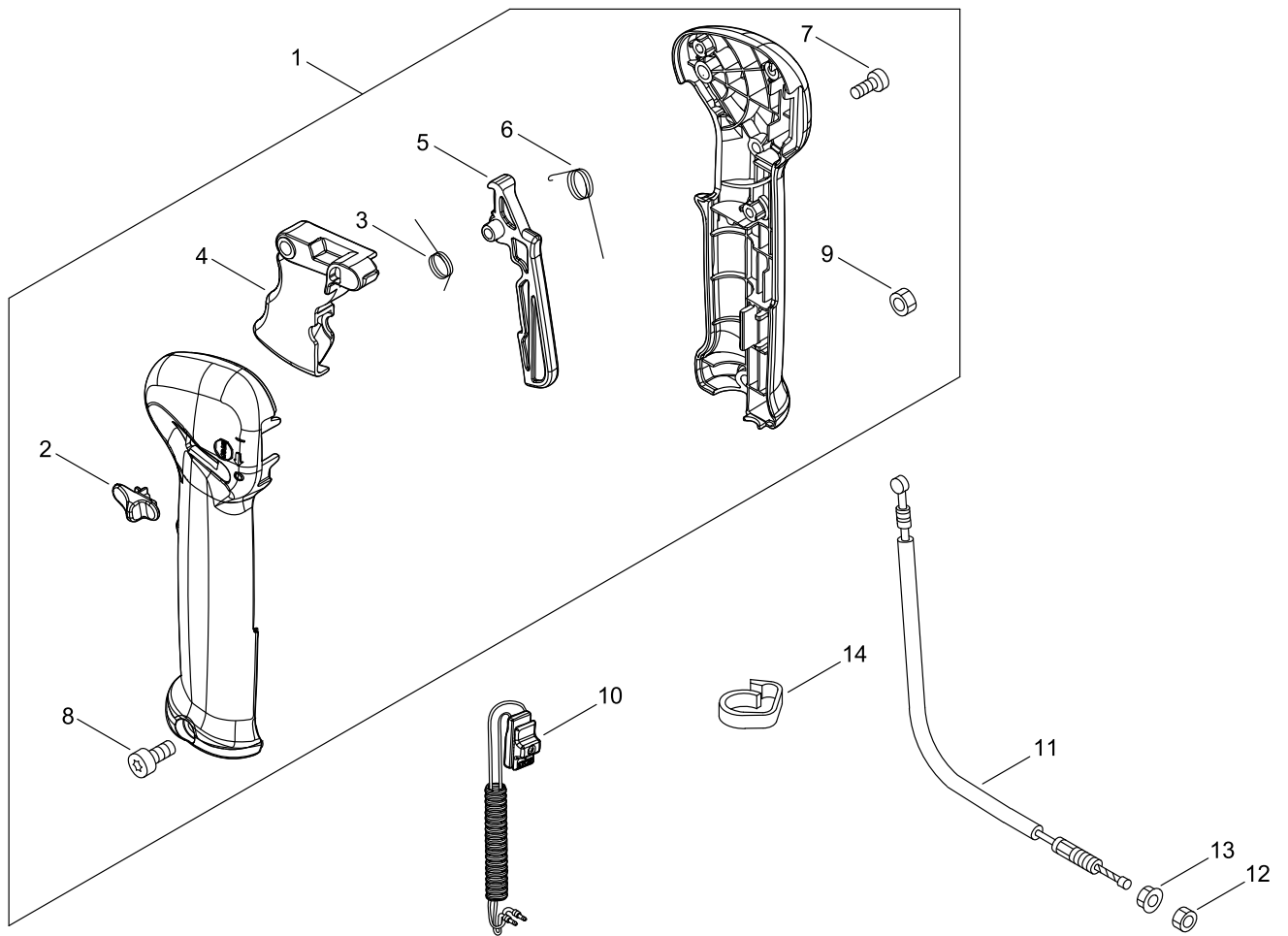

THROTTLE

KEY NO	LV(+)	Part No	Description	Qty	Standard	Comment
1		P100-004010	THROTTLE ASY	1		
2	+	C463-000020	KNOB, LATCH	1		
3	+	V452-000360	SPRING,TORSION	1		
4	+	C450-000270	CONTROL, THROTTLE	1		
5	+	C460-000111	LOCKOUT, THROTTLE	1	70MM	
6	+	V452-000350	SPRING,TORSION	1		
7	+	V804-000010	BOLT, TORX 4	3	TT-4*16 DG 10.9	
8	+	V805-000050	BOLT, TORX 5	1	TB-5*30 10.9	
9	+	900500-00005	NUT 5	1	5	
10		P100-004830	SWITCH,ON OFF	1		
11		V430-005140	CABLE,BOWDEN	1		
12		900502-00006	NUT 6 (3N)	1	3N6	
13		900518-00006	NUT, FLANGE	1	6	
14		159112-09961	CLIP	1		

ACCESSORIES

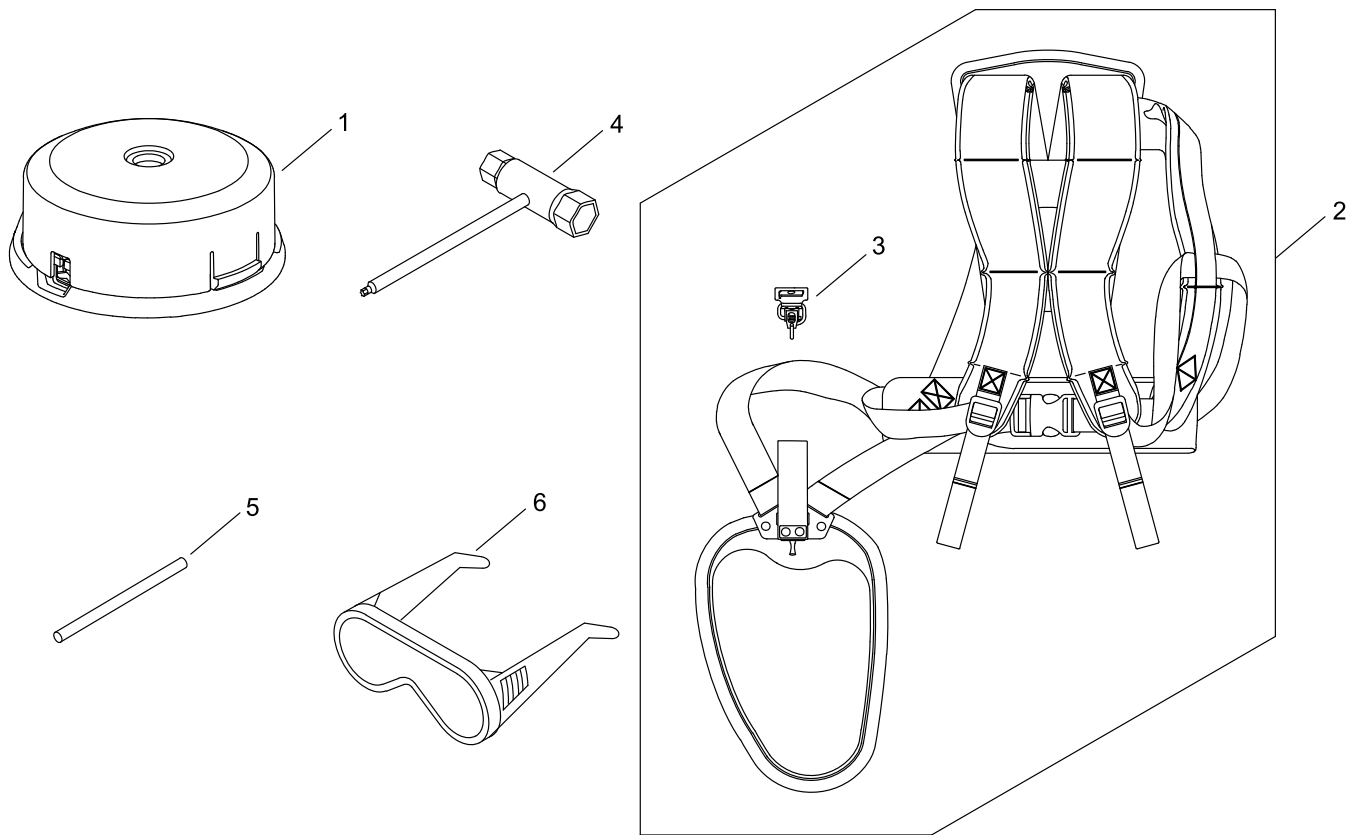

ACCESSORIES

KEY NO	LV(+)	Part No	Description	Qty	Standard	Comment
1		X047-001180	CUTTER,ASM LINE	1	Z-5/M10L	
2		C062-000511	HARNESS, SHOULDER	1		
3	+	P021-042910	HOOK ASSY	1		
4		X601-000020	TOOL,BOX SPANNER	1		
5		X606-000080	TOOL,BAR	1	5*120	
6		X690-000080	GOGGLE	1	SI CHINA, Z87.1	

NYLON LINE CUTTER

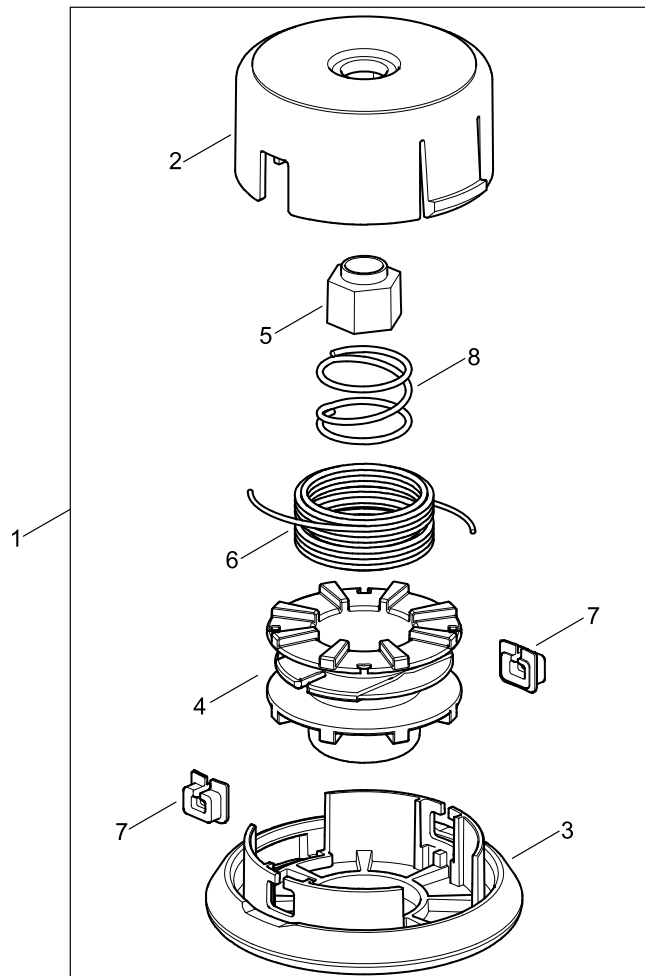

NYLON LINE CUTTER

KEY NO	LV(+)	Part No	Description	Qty	Standard	Comment
1		X047-001180	CUTTER,ASM LINE	1	Z-5/M10L	
2	+	P022-035000	HOUSING	1		
3	+	P022-010410	COVER	1		
4	+	P022-010400	BOBBIN	1		
5	+	P022-023180	NUT	1		
6	+	P022-010380	NYLON CODE	1		
7	+	P022-000710	EYELET	2	T4	
8	+	P022-010370	SPRING	1		

NUMERICAL PARTS INDEX

Part No	Part description	Page	Part No	Part description	Page	Part No	Part description	Page
125322-1-3930	SPRING, COIL	12	610313-5-2132	FIXTURE, BLADE	20	900702-0-0032	CIRCLIP 32	20
125323-0-8260	ARM, VALVE	12	610313-5-2932	FIXTURE, BLADE	20	900706-0-0012	CIRCLIP 12	20
125337-0-8260	VALVE, INLET NEEDLE	12	610314-5-2130	PLATE, ADAPTER (L)	20	900720-0-0012	O-RING 12	20
125338-1-3930	PIN, METERING ARM	12	610320-5-2130	NUT 10	20	900800-0-0609	BEARING, BALL 609	20
125339-4-2030	SCREW	12	610352-5-6830	PLATE, CUP	20	900803-0-0609	BEARING, BALL 609	20
125342-5-2130	COVER, DIAPHRAGM	12	610434-5-0031	BOLT 8* 8	20	900810-0-0629	BEARING, BALL 629	20
125344-1-3931	SCREW	12	699229-5-6830	PLATE, COVER	20	900812-0-6201	BEARING, BALL 6201	20
125344-5-2130	SCREW	12	890152-0-4930	LABEL, CAUTION	22	91316-04-010	SCREW	20
131016-5-5830	GASKET, FUEL CAP	14	890617-4-3130	LABEL, CAUTION	22	91341-03-006	SCREW SW	2
132115-5-5930	GROMMET, FUEL	14	900220-0-4006	SCREW 4*6	20	92419-28-000	C-RING	8
159112-0-9961	CLIP	24	900330-4-0080	PIN F 4*8	8	92424-42-000	SNAP RING	8
175048-0-5530	WASHER (I)	8	900330-5-0280	ROLLER	4	93115-03-010	KEY	6
175049-5-6030	WASHER	8	900500-0-0005	NUT 5	24	94018-46-001	BEARING, BALL	8
177214-4-1030	WASHER	18	900502-0-0006	NUT 6 (3N)	24	A011-00-1530	CRANKSHAFT, ASY	2
177220-4-2030	SPRING, REWIND	18	900515-0-0008	NUT, FLANGE 8	6	A021-00-4820	CARBURETOR, DIAPHRAGM	10
177228-4-4330	GRIP, STARTER	18	900518-0-0006	NUT, FLANGE	24	A021-00-4820	CARBURETOR, DIAPHRAGM	12
177236-6-1830	SCREW	18	900562-0-0005	NUT, LOCK	20	A023-00-0360	CASE, CLEANER	10
224924-5-2130	CLIP	22	900565-0-0005	NUT	20	A051-00-3330	STARTER, RECOIL ASY	18
301015-0-5330	HOOK, BAND	22	900565-5-0008	NUT	22	A052-00-0300	STARTER PULLEY	18
301205-2-1331	HOOK	22	900603-0-0005	WASHER 5	14	A101-00-0730	RING, PISTON	2
351312-5-2131	BRACKET, HANDLE (U)	22	900603-5-0008	WASHER	20	A127-00-0440	COVER, DUST	10
351313-5-2130	BRACKET, HANDLE (C)	22	900701-0-0009	CIRCLIP 9	20	A137-00-0040	COVER, ROCKER ARM	4
605014-5-4230	WASHER	22	900701-0-0012	CIRCLIP 12	8	A146-00-0020	WEIGHT, DECOMP	4
610011-2-5530	SHAFT, DRIVE	22	900702-0-0025	CIRCLIP 25	20	A160-00-3390	COVER, CYLINDER	2

NUMERICAL PARTS INDEX

Part No	Part description	Page	Part No	Part description	Page	Part No	Part description	Page
A160-00-3410	COVER,CYLINDER	2	A426-00-0010	TERMINAL, SPARKPLUG	6	C552-00-0200	PLATE, SHIELD	20
A172-00-3350	COVER,FAN	8	A427-00-0190	CAP,SPARK PLUG	6	C554-00-0001	KNIFE,CORD	20
A175-00-0390	STAND	14	A429-00-0220	COVER,CAP	2	C603-00-0240	PLATE	4
A200-00-1190	INSULATOR, INTAKE	10	A556-00-1810	DRUM, CLUTCH	8	E106-00-0240	GUIDE,AIR	6
A209-00-1070	PLATE, INSULATOR	10	A557-00-0150	SHAFT, CLUTCH	8	P005-00-0010	STRAINER	12
A211-00-0021	VALVE, REED	2	A566-00-0320	SPRING, CLUTCH	8	P005-00-0100	SCREW, THROTTLEADJUST	12
A212-00-0021	GUIDE, VALVE	2	A575-00-0640	FIXTURE, MAIN PIPE	8	P005-00-0190	E-RING	12
A226-00-0361	ELEMENT, AIR FILTER	10	A600-00-0020	LIFTER	4	P005-00-0200	GASKET, METERING	12
A226-00-2200	ELEMENT, AIR FILTER	10	A603-00-0090	VALVE	4	P005-00-0250	RETAINER	12
A235-00-0450	KNOB,CLEANER LID	10	A603-00-0100	VALVE	4	P005-00-0270	SCREW	12
A242-00-0280	LEVER, CHOKE	10	A604-00-0030	SPRING,VALVE	4	P005-00-0280	O-RING	12
A243-00-0380	SHUTTER, CHOKE	10	A606-00-0040	RETAINER	4	P005-00-0520	GASKET, PUMP	12
A244-00-0330	PLATE, PREVENT	10	A607-00-0030	ROD,PUSH	4	P005-00-1000	ROLLER, GUIDE	12
A310-00-0520	SCREEN, ARRESTOR	16	A610-00-0090	ARM,ROCKER	4	P005-00-1240	POST	12
A313-00-2070	GUIDE, EXHAUST	16	A622-00-0020	GEAR,CAM	4	P005-00-1270	PLUG, H AJUST SCREW	12
A320-00-1280	COVER,MUFFLER	16	C062-00-0511	HARNES, SHOULDER	26	P005-00-1900	SCREW	12
A350-00-2460	TANK, FUEL	14	C403-00-0031	GRIP,HANDLE	22	P005-00-3110	PUMP, PRIMER	12
A356-00-0050	VALVE,CHECK	14	C423-00-0030	FIXTURE,HANDLE	22	P005-00-3760	DIAPHRAGM , METERING	12
A365-00-0060	CONNECTOR,CAP	14	C423-00-0043	FIXTURE,HANDLE	22	P005-00-3930	DIAPHRAGM, PUMP	12
A369-00-0420	STRAINER, FUEL	14	C450-00-0270	CONTROL, THROTTLE	24	P005-00-3940	DIAPHRAGM, PUMP	12
A409-00-1340	ROTOR, MAGNETO	6	C460-00-0111	LOCKOUT, THROTTLE	24	P005-00-3950	SCREW,MAIN MIXTURE	12
A411-00-1770	COIL, IGNITION	6	C463-00-0020	KNOB, LATCH	24	P005-00-3960	SPRING, PUMP	12
A413-00-0100	BOOT	8	C534-00-1080	SHAFT, GEAR	20	P005-00-4240	BASE, ASY PRIMER	12
A425-00-0040	SPARKPLUG	6	C550-00-0541	SHIELD, BLADE	20	P021-01-2210	CAP,FUEL ASY	14

NUMERICAL PARTS INDEX

Part No	Part description	Page	Part No	Part description	Page	Part No	Part description	Page
P021-01-6221	HOOK ASS'Y	22	P100-00-4740	PISTON KIT	2	V392-00-0030	PLATE	4
P021-01-6232	FIXTURE,ASY HANDLE	22	P100-00-4750	CAM GEAR ASY	4	V430-00-5140	CABLE,BOWDEN	24
P021-04-2910	HOOK ASSY	26	P100-00-4760	COVER,CAM GEAR	4	V452-00-0350	SPRING,TORSION	24
P021-04-3981	SHIELD ASY, BLADE	20	P100-00-4780	COVER ASY, FAN	8	V452-00-0360	SPRING,TORSION	24
P021-04-6970	CLUTCH SHOE SET	8	P100-00-4790	CLEANER COVER ASY	10	V452-00-1310	SPRING,TORSION	20
P021-04-9000	MAIN PIPE ASY	22	P100-00-4810	MUFFLER ASY	16	V452-00-1800	SPRING,TORSION	4
P021-05-0810	SHIELD BLADE ASY	20	P100-00-4830	SWITCH,ON OFF	24	V471-00-1500	PIPE	14
P022-00-0710	EYELET	28	P100-00-4840	CASE,GEAR ASY	20	V471-00-4170	PIPE	14
P022-01-0370	SPRING	28	V000-00-0260	GEAR SET, BEVEL	20	V471-00-5290	PIPE	14
P022-01-0380	NYLON CODE	28	V103-00-1970	GASKET,INTAKE	10	V485-00-3010	LEAD	6
P022-01-0400	BOBBIN	28	V103-00-1980	GASKET,INTAKE	10	V485-00-3020	LEAD	6
P022-01-0410	COVER	28	V103-00-1990	GASKET,INTAKE	10	V490-00-0500	CLIP	14
P022-02-2010	NUT	18	V104-00-2360	GASKET,EXHAUST	16	V505-00-0011	SEAL,OIL 12	2
P022-02-3180	NUT	28	V104-00-2370	GASKET,EXHAUST	16	V505-00-0020	SEAL,OIL 12	2
P022-03-5000	HOUSING	28	V109-00-0040	GASKET	4	V555-00-0010	BEARING,NEEDLE 10	2
P022-04-5770	GUIDE, ROPE	18	V109-00-0340	GASKET	4	V580-00-0010	RING,END	2
P022-04-9760	CASE, STARTER	18	V203-00-2400	BOLT,5	6	V581-00-0790	RING,O	10
P022-04-9770	DRUM, STARTER	18	V252-00-0930	SCREW,4	4	V608-00-0000	PIN,ENG 10	2
P022-04-9780	COLLAR	18	V263-00-0500	NUT,5	4	V804-00-0010	BOLT, TORX 4	24
P022-04-9790	SWING ARM	18	V299-00-0110	KNOB,FASTENER	22	V804-00-0030	BOLT, TORX 4	16
P022-04-9800	ROPE, STARTER	18	V303-00-0220	WASHER	4	V804-00-0040	BOLT, TORX 4	4
P100-00-3860	HANDLE ASY	22	V307-00-0580	WASHER,CIRCULAR 10	2	V804-00-0050	BOLT, TORX 4	4
P100-00-4010	THROTTLE ASY	24	V340-00-0180	WASHER	20	V804-00-0120	BOLT, TORX 4	10
P100-00-4730	CYL. CRANKCASE SET	2	V353-00-0720	COLLAR,5	4	V805-00-0050	BOLT, TORX 5	24

NUMERICAL PARTS INDEX

Part No	Part description	Page	Part No	Part description	Page
V805-00-0100	BOLT, TORX 5	10	X606-00-0080	TOOL,BAR	26
V805-00-0130	BOLT, TORX 5	20	X690-00-0080	GOGGLE	26
V805-00-0140	BOLT, TORX 5	2			
V805-00-0140	BOLT, TORX 5	10			
V805-00-0140	BOLT, TORX 5	16			
V805-00-0140	BOLT, TORX 5	18			
V805-00-0140	BOLT, TORX 5	22			
V805-00-0150	BOLT, TORX 5	8			
V805-00-0150	BOLT, TORX 5	20			
V805-00-0170	BOLT, TORX 5	8			
V805-00-0170	BOLT, TORX 5	14			
V805-00-0170	BOLT, TORX 5	20			
V805-00-0170	BOLT, TORX 5	22			
V805-00-0250	BOLT, TORX 5	2			
V805-00-0250	BOLT, TORX 5	16			
V805-00-0260	BOLT, TORX 5	20			
V806-00-0020	BOLT, TORX 6	20			
X047-00-1180	CUTTER,ASM LINE	26			
X047-00-1180	CUTTER,ASM LINE	28			
X502-00-0390	LABEL,ECHO	2			
X530-00-0560	LABEL,EYE CATCHER	20			
X530-00-0590	LABEL,EYE CATCHER	2			
X547-00-3280	LABEL,ECHO	18			
X601-00-0020	TOOL,BOX SPANNER	26			