



PARTS CATALOG

GRASS-TRIMMER / BRUSHCUTTER

SRM-2015(SI)

SRM-2015(SI)

1. Cylinder, Crankcase, Piston, Fan Cover

No.1

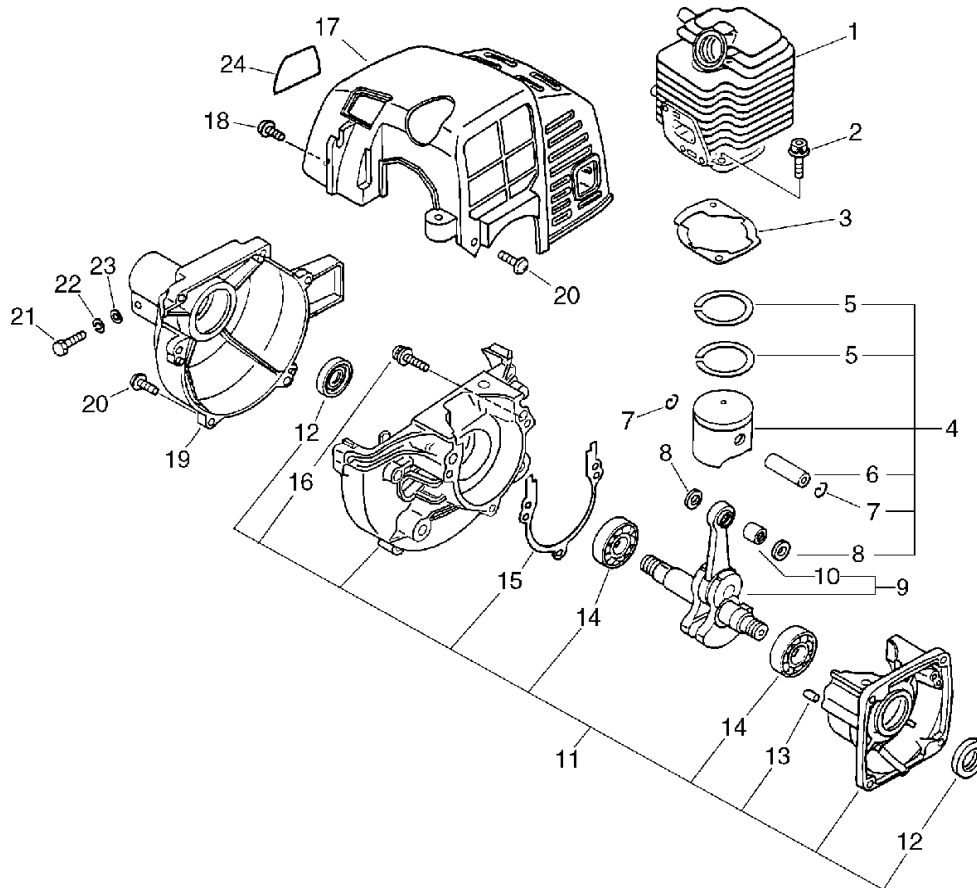

KEY	LV	PART NUMBER	Q'TY	DESCRIPTION	REMARKS	NOTE1	NOTE2
1		101011-06560	1	CYLINDER		Sus. by 101011-06562	
1		101011-06561	1	CYLINDER		Sus. by 101011-06562	
1		101011-06562	1	CYLINDER			
2		900162-05022	2	BOLT, H.S. 5*22	5*22 W,SW		
3		101010-44332	1	GASKET, CYL. BASE			
4		100000-48730	1	PISTON KIT		Sus. by 100000-48732	
4		100000-48731	1	PISTON KIT		Sus. by 100000-48732	
4		100000-48732	1	PISTON KIT			
5	+	100011-05330	2	RING, PISTON			
6	+	100013-11520	1	PIN, PISTON			
7	+	100015-04630	2	CIRCLIP, PISTON PIN			
8	+	100014-11520	2	SPACER, PISTON PIN			
9		100100-54130	1	CRANKSHAFT ASSY		Sus. by A011-000101	
9		100100-44732	1	CRANKSHAFT ASSY		Sus. by A011-000101	
9		100100-44733	1	CRANKSHAFT		Sus. by A011-000101	
9		A011-000101	1	CRANKSHAFT,ASM			
10	+	100012-51230	1	BEARING, NEEDLE	8*12*10	Sus. by V553-000010	

1. Cylinder, Crankcase, Piston, Fan Cover

No.1

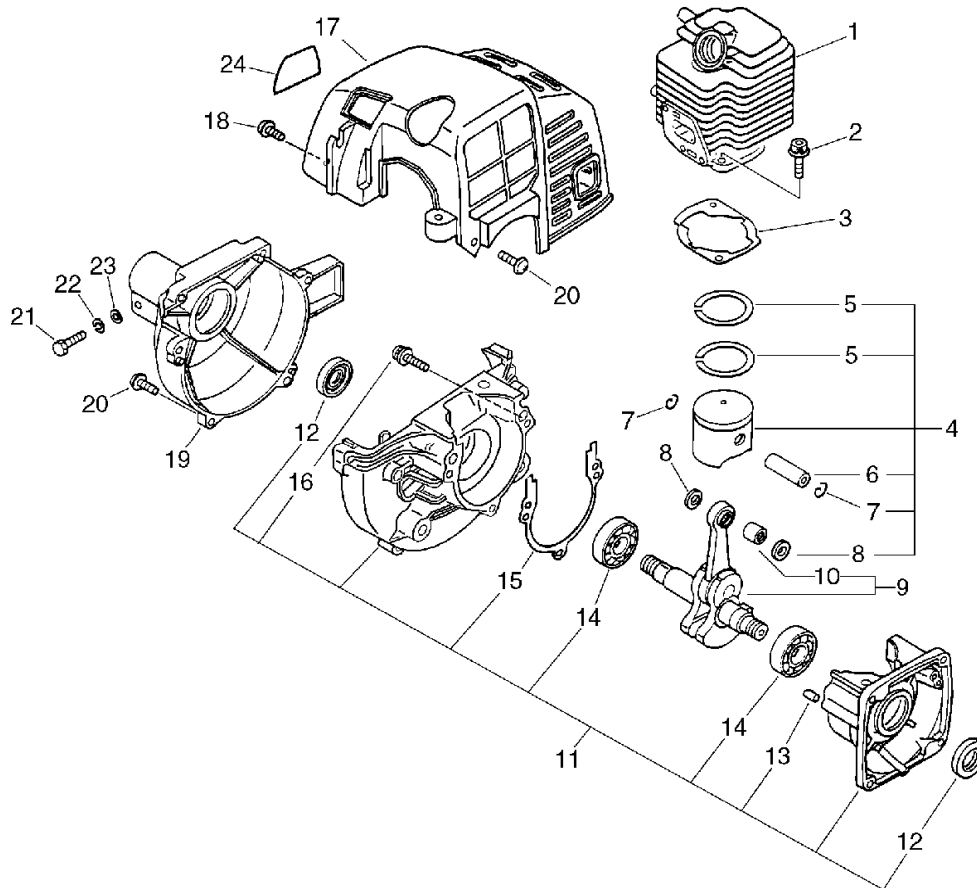

KEY	LV	PART NUMBER	Q'TY	DESCRIPTION	REMARKS	NOTE1	NOTE2
10	+	V553-000030	1	BEARING,NEEDLE 8		Sus. by V553-000010	
10	+	V553-000010	1	BEARING,NEEDLE 8	HK0810		
11		100204-52130	1	CRANKCASE KIT		Sus. by 100204-52132	
11		100204-52131	1	CRANKCASE KIT		Sus. by 100204-52132	
11		100204-52132	1	CRANKCASE KIT			
12	+	100212-42030	2	OILSEAL	ISCD12*22*4.5	Sus. by 100212-42031	
12	+	100212-42031	2	OILSEAL	ISCD 12*22*4.5		
13	+	100215-03930	2	PIN, DOWEL			
14	+	900810-36201	2	BEARING, BALL 6201	6201/C3	Sus. by 94035-36201	
14	+	94035-36201	2	BEARING BALL	6201X3JR2C3		
15	+	100242-42030	1	GASKET, CRANKCASE			
16	+	900162-05028	3	BOLT, H.S. 5*28	5*28 W,SW		
17		101514-44731	1	COVER, CYLINDER		Sus. by 101514-42031	
17		101514-42031	1	COVER, CYLINDER			
18		900238-04012	2	SCREW 4*12	4*12		
19		101511-44630	1	COVER, FAN (BS)			
20		900238-04016	6	SCREW 4*16	4*16		
21		900151-05025	1	BOLT 5*25	5*25 S45C		
22		900605-00005	1	WASHER, SPRING 5	5		

1. Cylinder, Crankcase, Piston, Fan Cover

No.1

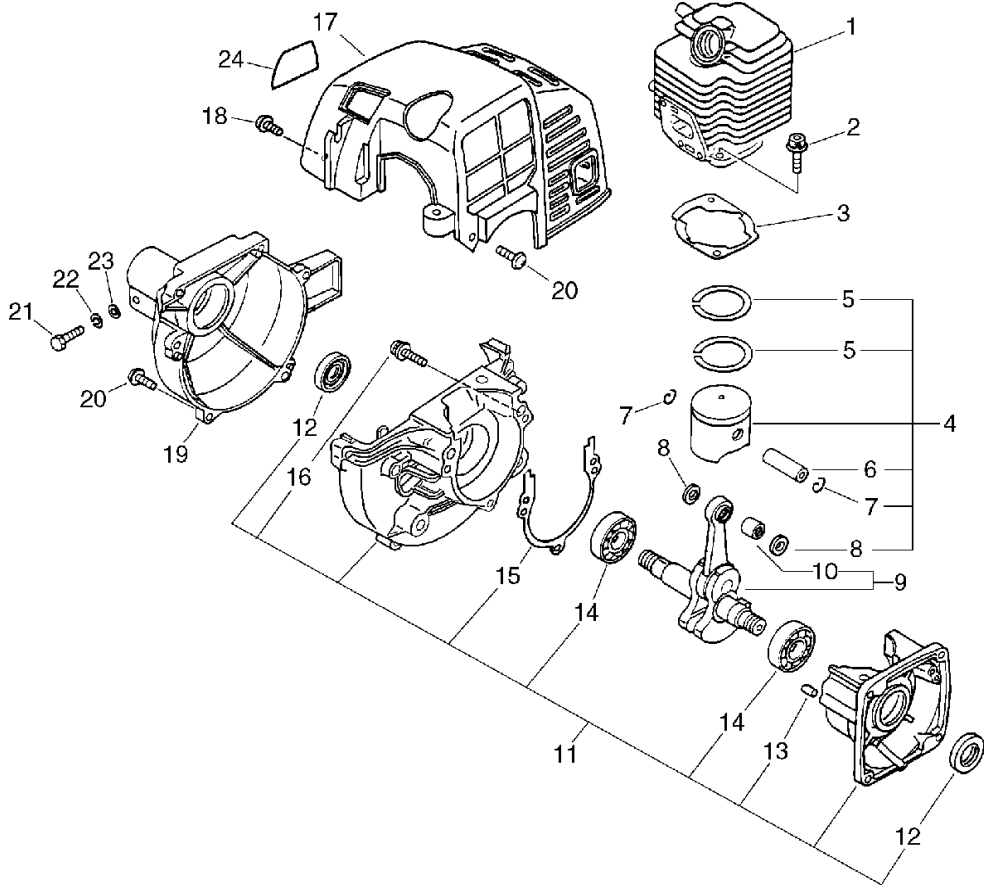

KEY	LV	PART NUMBER	Q'TY	DESCRIPTION	REMARKS	NOTE1	NOTE2
23		900600-00005	1	WASHER 5	5		
24		890611-46730	1	LABEL, MODEL		SRM-2015	
24		X543-000110	1	LABEL, MODEL	SRM-2015SI	SRM-2015S	

2. Magneto, Clutch

No.2

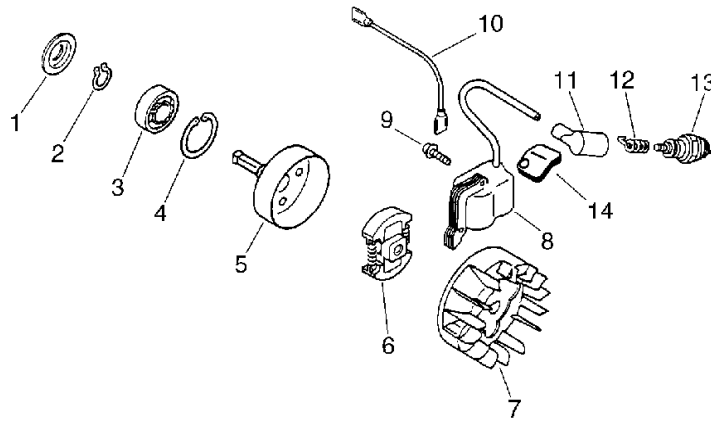

KEY	LV	PART NUMBER	Q'TY	DESCRIPTION	REMARKS	NOTE1	NOTE2
1		175053-04920	1	STOPPER			
2		900701-00012	1	CIRCLIP 12	CS-12		
3		900814-06201	1	BEARING, BALL 6201	6201ZZ		
4		900702-00032	1	CIRCLIP 32	CR-32		
5		175005-46730	1	DRUM, CLUTCH			
6		175000-52130	1	CLUTCH ASSY		Sus. by 175000-52131	
6		175000-52131	1	CLUTCH ASSEMBLY			
7		156801-44731	1	FLYWHEEL		Sus. by 156801-44731	
7		156801-12360	1	ROTOR, MAGNETO		Sus. by 156801-44731	
7		156801-44731	1	FLYWHEEL			
8		156601-52130	1	COIL, IGNITION			
9		900162-04022	2	BOLT, H.S. 4*22	4*22 W,SW		
10		162021-52130	1	LEAD	210L	Sus. by 162010-52830	
10		162010-52830	1	LEAD, GROUND			
11		159012-01620	1	CAP, SPARK PLUG			
12		159011-03432	1	COIL, SPARK PLUG			
13		159017-10230	1	PLUG, SPARK (RCJ-7Y)	RCJ-7Y	Sus. by 159010-10230	
13		159010-10230	1	PLUG, SPARK (BPMR-7A)	BPMR-7A		
14		150112-42030	1	BUSHING			

3. Starter(SRM-2015)

No.3

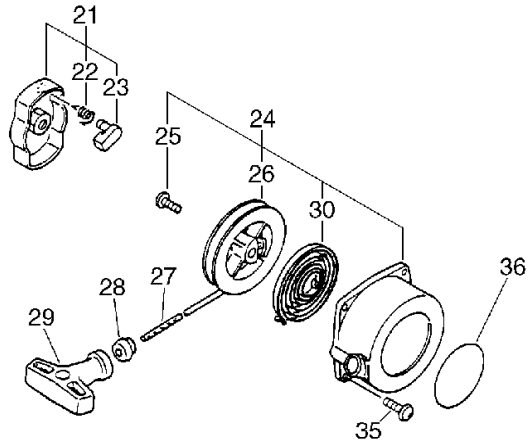

KEY	LV	PART NUMBER	Q'TY	DESCRIPTION	REMARKS	NOTE1	NOTE2
21		177202-44330	1	PAWL ASSY, STARTER		Sus. by 177202-44331	
21		177202-44331	1	PAWL ASM., STARTER		SRM-2015	
22	+	177234-42030	1	SPRING, RETURN		SRM-2015	
23	+	177218-44330	1	PAWL, STARTER	BLACK	SRM-2015	
24		177200-42033	1	STARTER ASSY		SRM-2015	
25	+	177236-44330	1	SCREW		SRM-2015	
26	+	177215-44430	1	DRUM, STARTER		SRM-2015	
27	+	177226-10120	1	ROPE, STARTER	3.0*1000	SRM-2015	
28	+	177227-42030	1	GUIDE, ROPE		SRM-2015	
29	+	177228-06530	1	GRIP, STARTER		SRM-2015	
30	+	177220-42030	1	SPRING, REWIND		SRM-2015	
35		900238-04016	2	SCREW 4*16	4*16	SRM-2015	
36		890118-49130	1	LABEL, ECHO		SRM-2015	

4. Starter(SRM-2015SI)

No.4

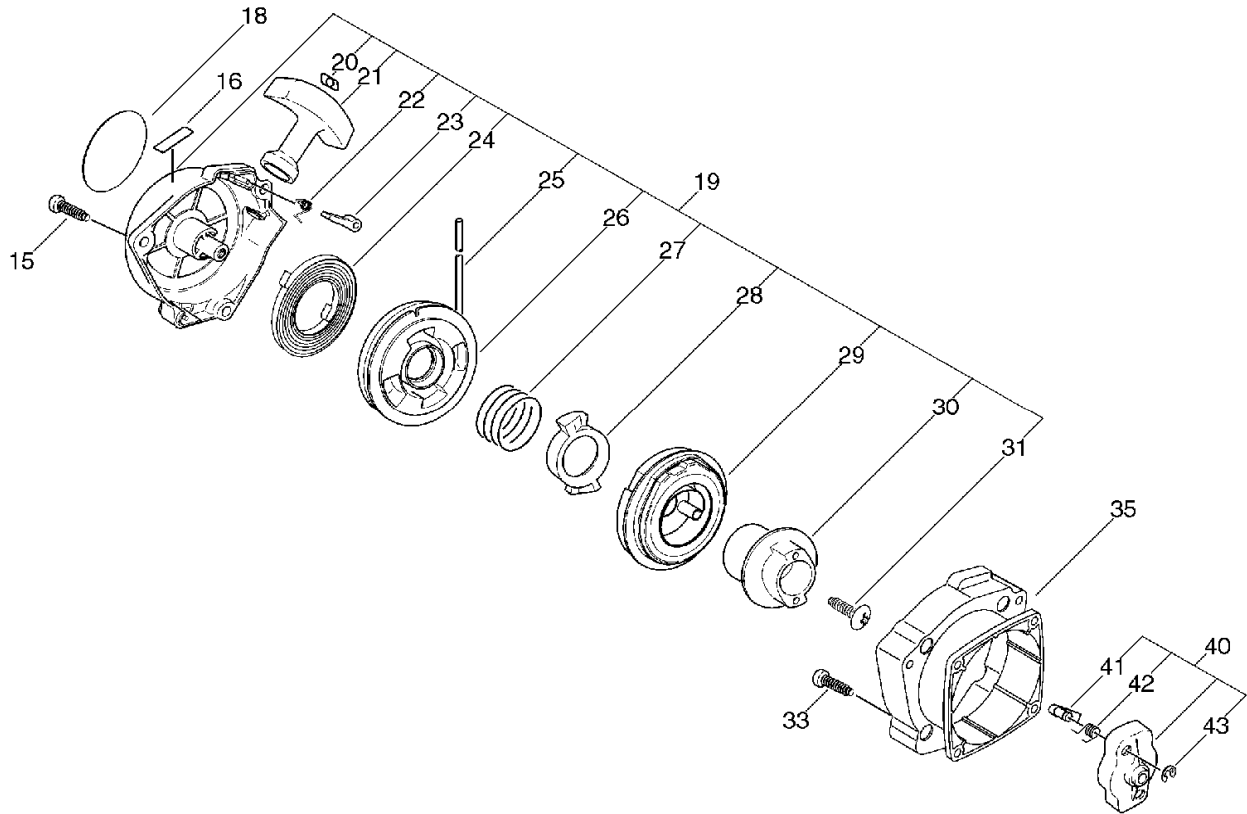

KEY	LV	PART NUMBER	Q'TY	DESCRIPTION	REMARKS	NOTE1	NOTE2
15		900253-05020	3	SCREW 5*20	5*20	SRM-2015SI	
16		X505-000620	1	LABEL,CAUTION		SRM-2015SI	
18		X502-000031	1	LABEL,ECHO		Sus. by X502-000032	
18		X502-000032	1	LABEL,ECHO		SRM-2015SI	
19		A051-000290	1	STARTER,RECOIL		Sus. by A051-000291	
19		A051-000291	1	STARTER,RECOIL		SRM-2015SI	
19		A051-000292	1	STARTER,RECOIL			
20	+	177246-11120	1	CLIP, STARTER ROPE		SRM-2015SI	
21	+	177228-27030	1	GRIP, STARTER		SRM-2015SI	
22	+	P022-004610	2	SPRING, RETURN		SRM-2015SI	
23	+	P022-004620	2	PAWL, STARTER		SRM-2015SI	
24	+	P022-004680	1	SPRING, SPIRAL		SRM-2015SI	
25	+	P022-004600	1	ROPE,STARTER	3.0*920	SRM-2015SI	
26	+	P022-004690	1	REEL,ROPE		SRM-2015SI	
27	+	P022-004660	1	SPRING, RETURN		SRM-2015SI	
28	+	P022-004670	1	PAWL, STARTER		SRM-2015SI	
29	+	P022-004650	1	COMPLETE,SPRING		Sus. by P022-005230	
29	+	P022-005230	1	COMPLETE,SPRING		SRM-2015SI	
30	+	P022-004640	1	PLATE,CAM		SRM-2015SI	
31	+	P022-004630	1	SCREW		SRM-2015SI	
33		900162-04016	2	BOLT, H.S. 4*16	4*16 W,SW	Sus. by 900238-04016	
33		900238-04016	2	SCREW 4*16	4*16	SRM-2015SI	

4. Starter(SRM-2015SI)

No.4

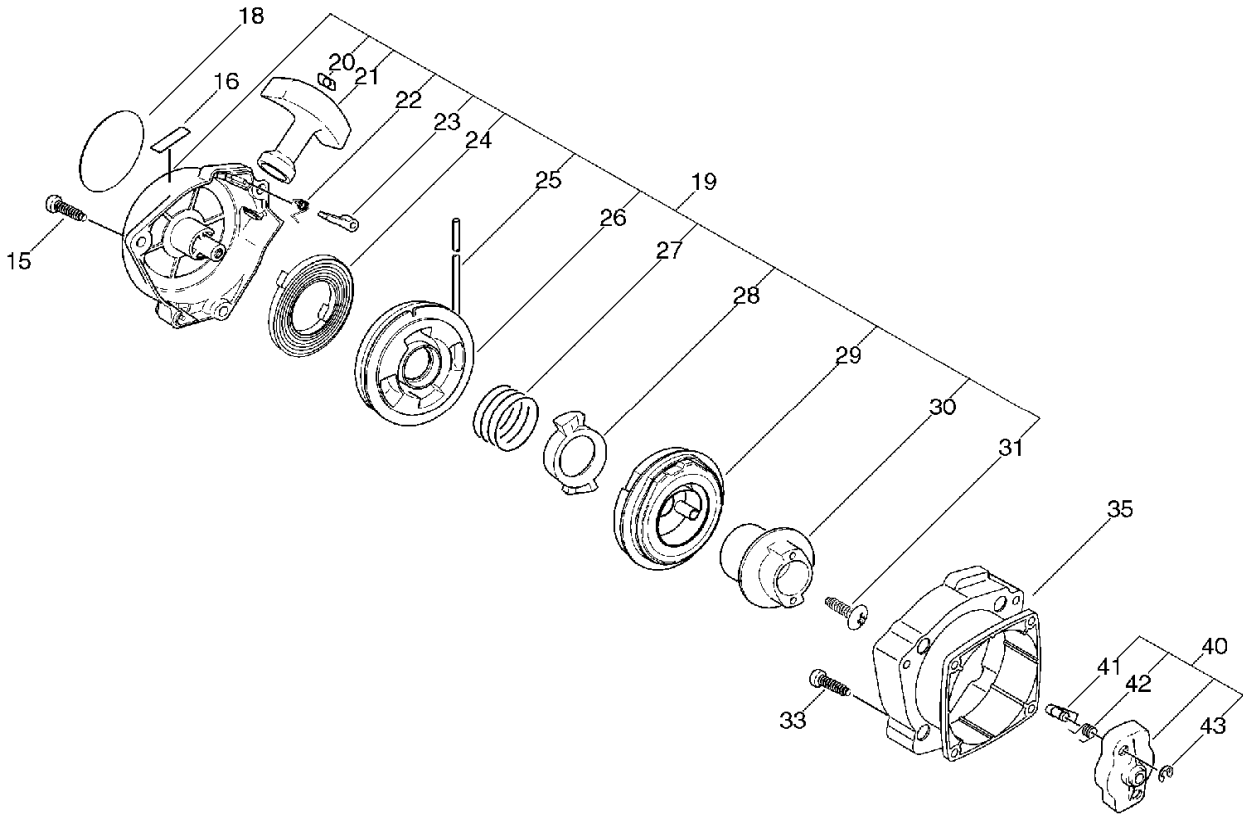

KEY	LV	PART NUMBER	Q'TY	DESCRIPTION	REMARKS	NOTE1	NOTE2
35		V376-000360	1	SPACER		Sus. by V376-000361	
35		V376-000361	1	SPACER		SRM-2015SI	
40		A052-000130	1	PULLEY,ASM STARTER		SRM-2015SI	
41	+	P022-004740	2	PAWL,STARTER		SRM-2015SI	
42	+	177234-42030	2	SPRING, RETURN		SRM-2015SI	
43	+	P022-002100	2	E-RING	4	SRM-2015SI	

5. Air Cleaner, Muffler

No.5

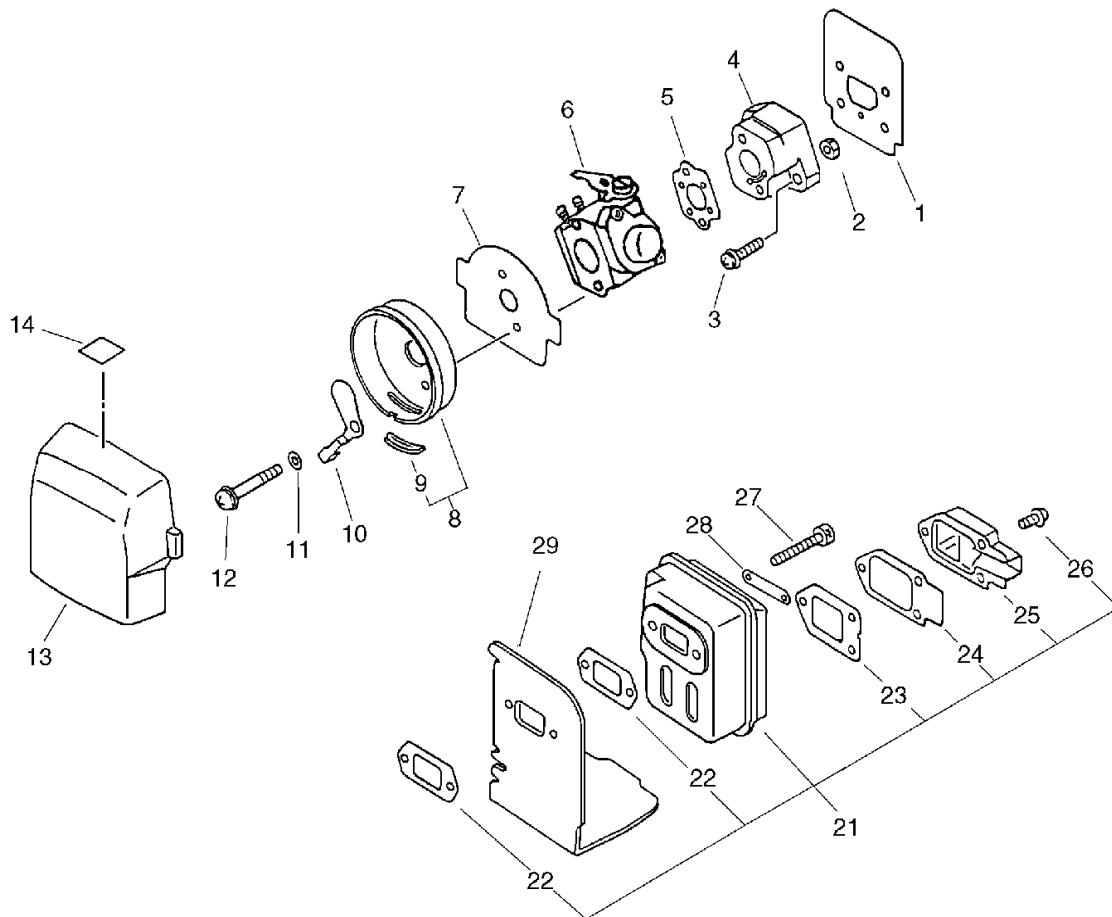

KEY	LV	PART NUMBER	Q'TY	DESCRIPTION	REMARKS	NOTE1	NOTE2
1		130010-42032	1	GASKET,INTAKE			
2		900500-00005	2	NUT 5	5		
3		900238-05020	2	SCREW 5*20	5*20		
4		130017-42031	1	INSULATOR, INTAKE			
5		130016-42031	1	GASKET, INTAKE			
6		125200-52430	1	CARBURETOR ASSY	C1U-K53	Sus. by 125200-52433	
6		125200-52431	1	CARBURETOR	C1U-K53	Sus. by 125200-52433	
6		125200-52432	1	CARBURETOR	C1U-K53A	Sus. by 125200-52433	
6		125200-52433	1	CARBURETOR	C1U-K53B		
7		130319-42030	1	FIXTURE,AIR CLEANER			
8		130301-42030	1	CASE, AIR CLEANER			
9	+	178810-42030	1	GROMMET, CHOKE			
10		178515-42030	1	SHUTTER, CHOKE		Sus.by 178515-46731	
10		178515-46731	1	SHUTTER, CHOKE	φ3.0		
11		178516-00830	2	SPACER	5.2*8*0.8T		
12		900242-05057	2	SCREW 5*57	5*57		
13		130310-46730	1	FILTER, AIR			
14		890169-47530	1	LABEL, ADJUSTING			
21		P021-000050	1	MUFFLER ASY			
22	+	145510-42031	2	GASKET, MUFFLER		Sus.by V104-000160	
22	+	V104-000160	2	GASKET,EXHAUST			

5. Air Cleaner, Muffler

No.5

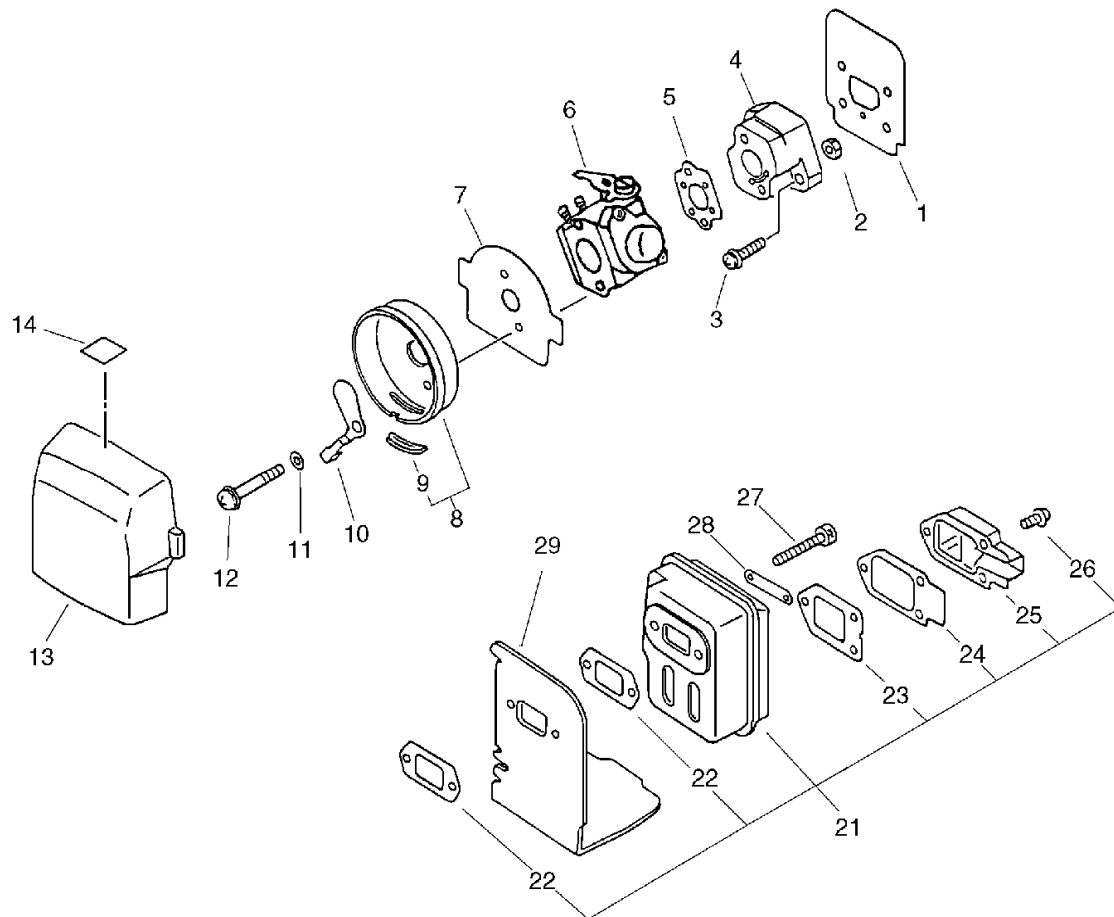

KEY	LV	PART NUMBER	Q'TY	DESCRIPTION	REMARKS	NOTE1	NOTE2
23	+	145866-42031	1	GASKET, MUFFLER LID			
24	+	145863-42030	1	HOLDER, SCREEN			
25	+	145876-42030	1	LID, MUFFLER (B)			
26	+	900242-04010	3	SCREW 4*10	4*10		
27		900105-05055	2	BOLT, H.S. 5*55	5*55		
28		900600-00005	2	WASHER 5	5	Sus. by 145642-04930	
28		145642-04930	1	WASHER			
29		145631-42030	1	COVER, MUFFLER		Sus. by A320-000251	
29		A320-000250	1	COVER, MUFFLER		Sus. by A320-000251	
29		A320-000251	1	COVER, MUFFLER			

6. Fuel Tank

No.6

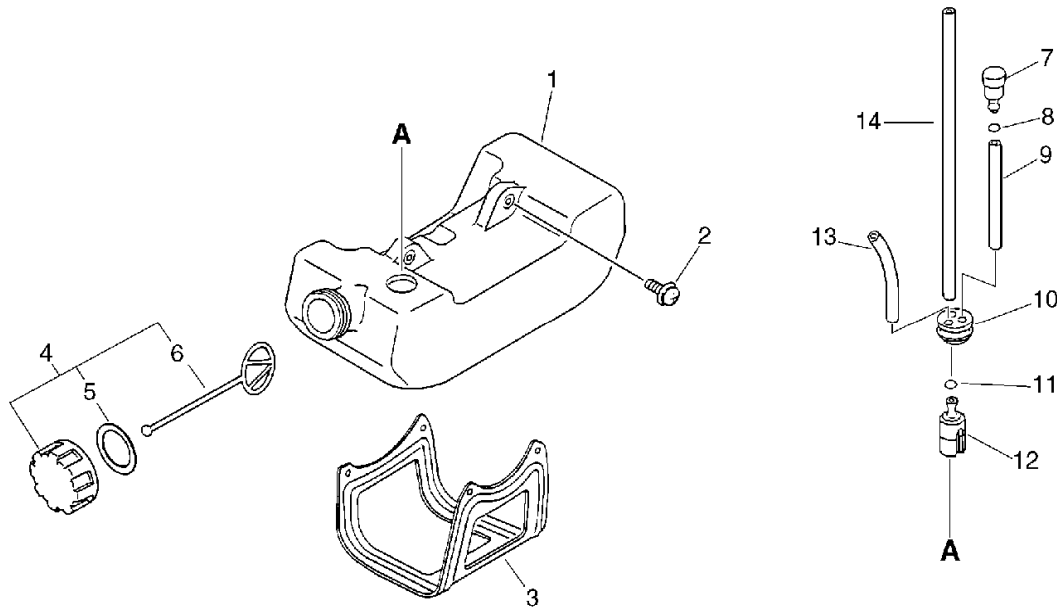

KEY	LV	PART NUMBER	Q'TY	DESCRIPTION	REMARKS	NOTE1	NOTE2
1		131005-44331	1	TANK, FUEL		Sus. by 131005-44332	
1		131005-44332	1	TANK, FUEL			
2		900243-05016	2	SCREW 5*16	5*16		
3		305110-42030	1	STAND (BL)			
4		131004-55530	1	CAP ASSY, FUEL TANK			
5	+	131016-55830	1	GASKET, FUEL CAP			
6	+	131051-56030	1	CLIP, FUEL CAP	100L		
7		131300-56430	1	VALVE, CHECK			
8		130111-00530	1	CLIP	5.5		
9		131312-44330	1	PIPE, 3*5*70L	3*5*70L NBR		
9		V471-001200	1	PIPE	3*5*70 NBR		
10		132115-46730	1	GROMMET, FUEL			
11		132013-09820	1	CLIP	6MM		
12		131205-07320	1	STRAINER, FUEL			
13		132010-56330	1	PIPE 3*6*90	3*6*90 YL		
14		132010-13930	1	PIPE, FUEL	3*5*180L NBR	Sus. by V471-001190	
14		V471-001190	1	PIPE	3*5*180 NBR		

7. Shield(Sr/Nr 035852 and before/SRM-2015)

No.7

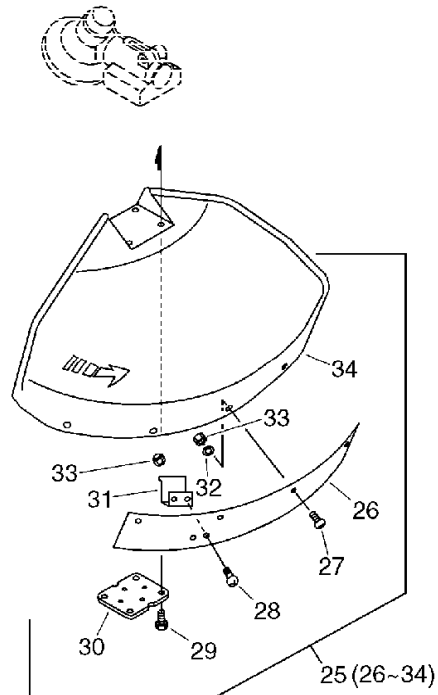

KEY	LV	PART NUMBER	Q'TY	DESCRIPTION	REMARKS	NOTE1	NOTE2
25		699000-52930	1	SHIELD ASSY		Sus. by 699000-52931	
25		699000-52931	1	SHIELD ASY		Sr/Nr 035852 and before/SRM-2015	
26	+	699013-52130	1	PLATE, SHIELD		Sr/Nr 035852 and before/SRM-2015	
27	+	900162-05018	4	BOLT, H.S. 5*18	5*18 W,SW	Sr/Nr 035852 and before/SRM-2015	
28	+	900162-05014	2	BOLT, H.S. 5*14	5*14 W,SW	Sr/Nr 035852 and before/SRM-2015	
29	+	900162-05025	4	BOLT, H.S. 5*25	5*25 W,SW		
30	+	699013-56830	1	PLATE, SHIELD			
31	+	699016-52130	1	KNIFE, CORD		Sus. by 699016-54530	
31	+	699016-54530	1	KNIFE		Sr/Nr 035852 and before/SRM-2015	
32	+	900603-00005	4	WASHER 5	5.5*12*0.8	Sr/Nr 035852 and before/SRM-2015	

7. Shield(Sr/Nr 035852 and before/SRM-2015)
 No.7

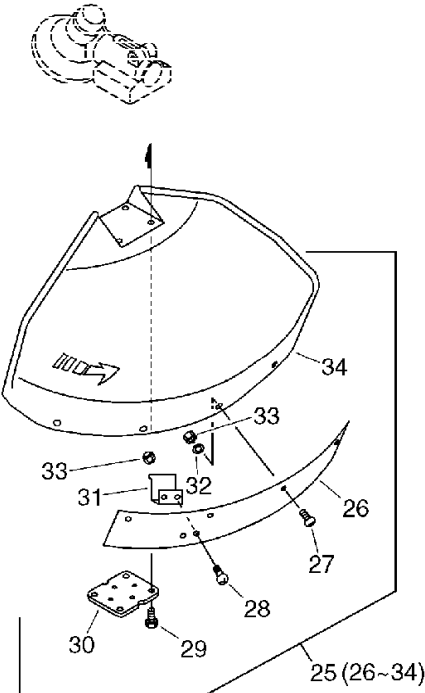

KEY	LV	PART NUMBER	Q'TY	DESCRIPTION	REMARKS	NOTE1	NOTE2
33	+	900500-00005	6	NUT 5	5	Sr/Nr 035852 and before/SRM-2015	
34	+	699010-52930	1	SHIELD, BLADE		Sus. by 699010-52931	
34	+	699010-52931	1	SHIELD,BLADE		Sr/Nr 035852 and before/SRM-2015	

8. Shield(Sr/Nr 035853 and after/SRM-2015,SRM-2015SI), Tools

No.8

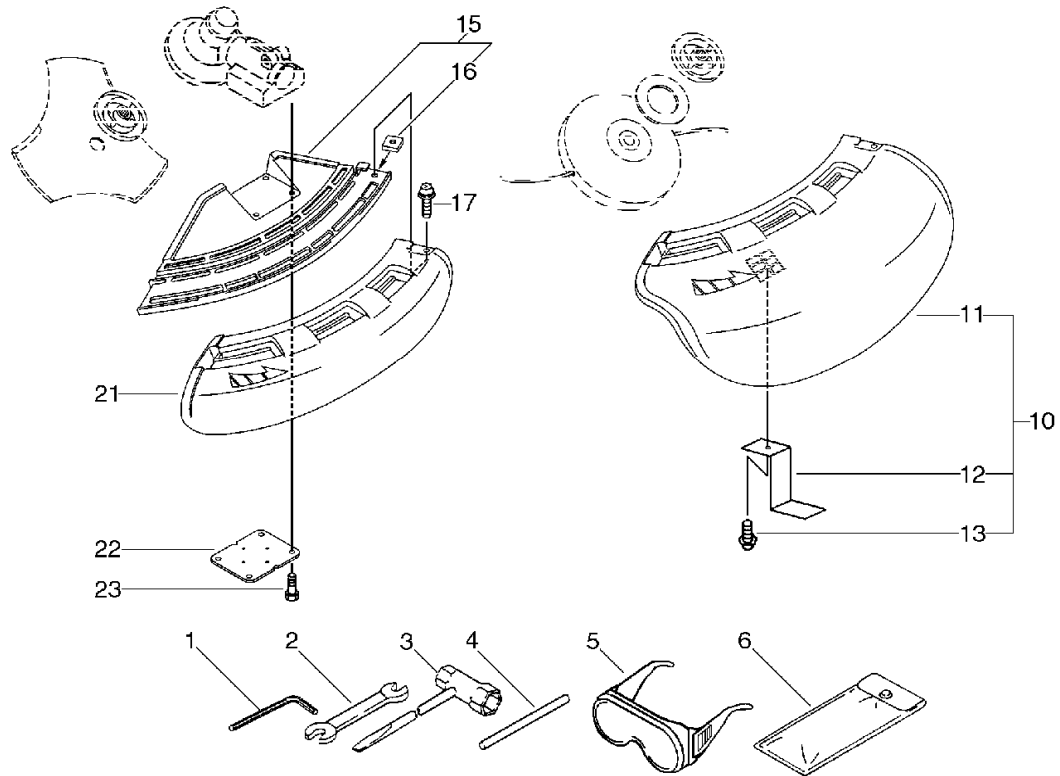

KEY	LV	PART NUMBER	Q'TY	DESCRIPTION	REMARKS	NOTE1	NOTE2
1		895610-00130	1	L-WRENCH (4MM)			
2		895112-00330	1	SPANNER 8*10			
3		895410-08030	1	WRENCH, W/S. DRIVER		Sus. by X602-000020	
3		X602-000020	1	TOOL,WRENCH	17*19 L200		
4		897518-01131	1	LOCKING TOOL			
5		899580-40930	1	GOGGLE		Sus. by P021-002861	
5		899580-68730	1	SAFETY GLASSES		Sus. by P021-002861	
5		X690-000030	1	GOGGLE		Sus. by P021-002861	
5		P021-002861	1	GOGGLES			
6		898510-39130	1	BAG, TOOL			
10		P021-002620	1	SHIELD,BLADE(W/KNIFE		Sr/Nr 035853 and after/SRM-2015	
10		P021-002620	1	SHIELD,BLADE(W/KNIFE		SRM-2015SI	
11	+	C550-000080	1	SHIELD,BLADE		Sr/Nr 035853 and after/SRM-2015	
11	+	C550-000080	1	SHIELD,BLADE		SRM-2015SI	
12	+	C554-000000	1	KNIFE,CORD		Sr/Nr 035853 and after/SRM-2015	
12	+	C554-000000	1	KNIFE,CORD		SRM-2015SI	

8. Shield(Sr/Nr 035853 and after/SRM-2015,SRM-2015SI), Tools

No.8

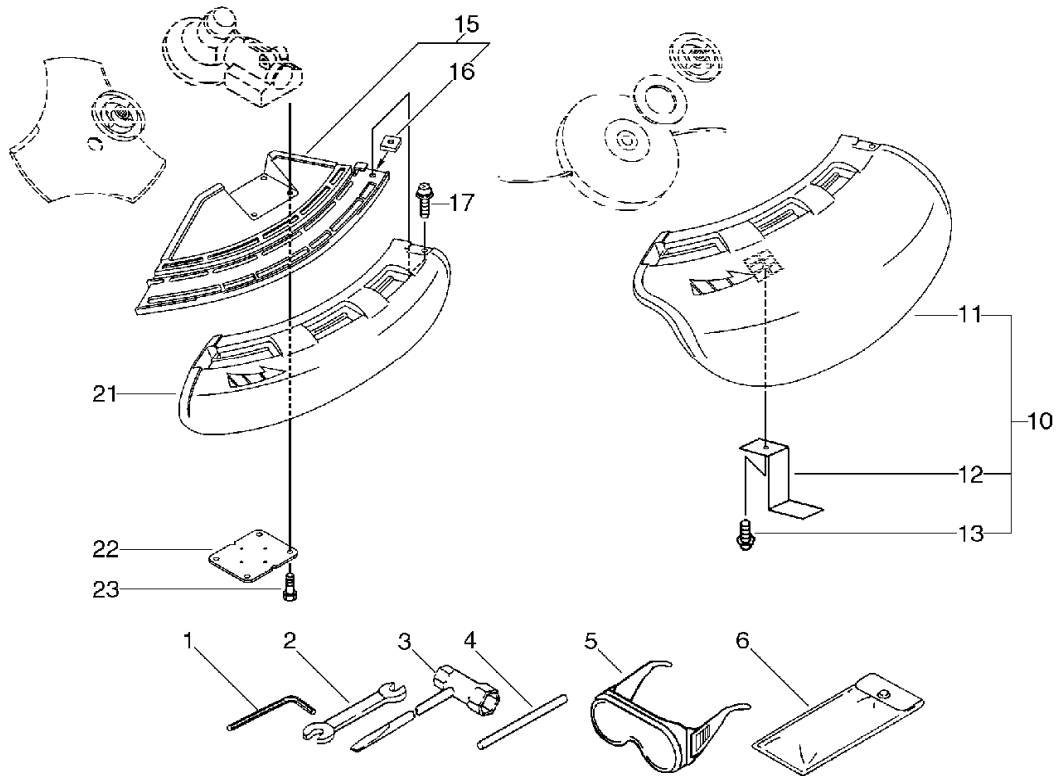

KEY	LV	PART NUMBER	Q'TY	DESCRIPTION	REMARKS	NOTE1	NOTE2
13	+	900252-05012	1	SCREW 5*12	5*12	Sr/Nr 035853 and after/SRM-2015	
13	+	900252-05012	1	SCREW 5*12	5*12	SRM-2015SI	
15		C550-000100	1	SHIELD,BLADE		Sr/Nr 035853 and after/SRM-2015	
15		C550-000100	1	SHIELD,BLADE		SRM-2015SI	
16	+	900565-00005	1	NUT	5	Sr/Nr 035853 and after/SRM-2015	
16	+	900565-00005	1	NUT	5	SRM-2015SI	
17		900242-05018	1	SCREW 5*18	5*18	Sr/Nr 035853 and after/SRM-2015	
17		900242-05018	1	SCREW 5*18	5*18	SRM-2015SI	
21		C550-000090	1	SHIELD,BLADE		Sr/Nr 035853 and after/SRM-2015	
21		C550-000090	1	SHIELD,BLADE		SRM-2015SI	
22		699013-56830	1	PLATE, SHIELD			
23		900162-05025	4	BOLT, H.S. 5*25	5*25 W,SW		

9. U-Handle

No.9

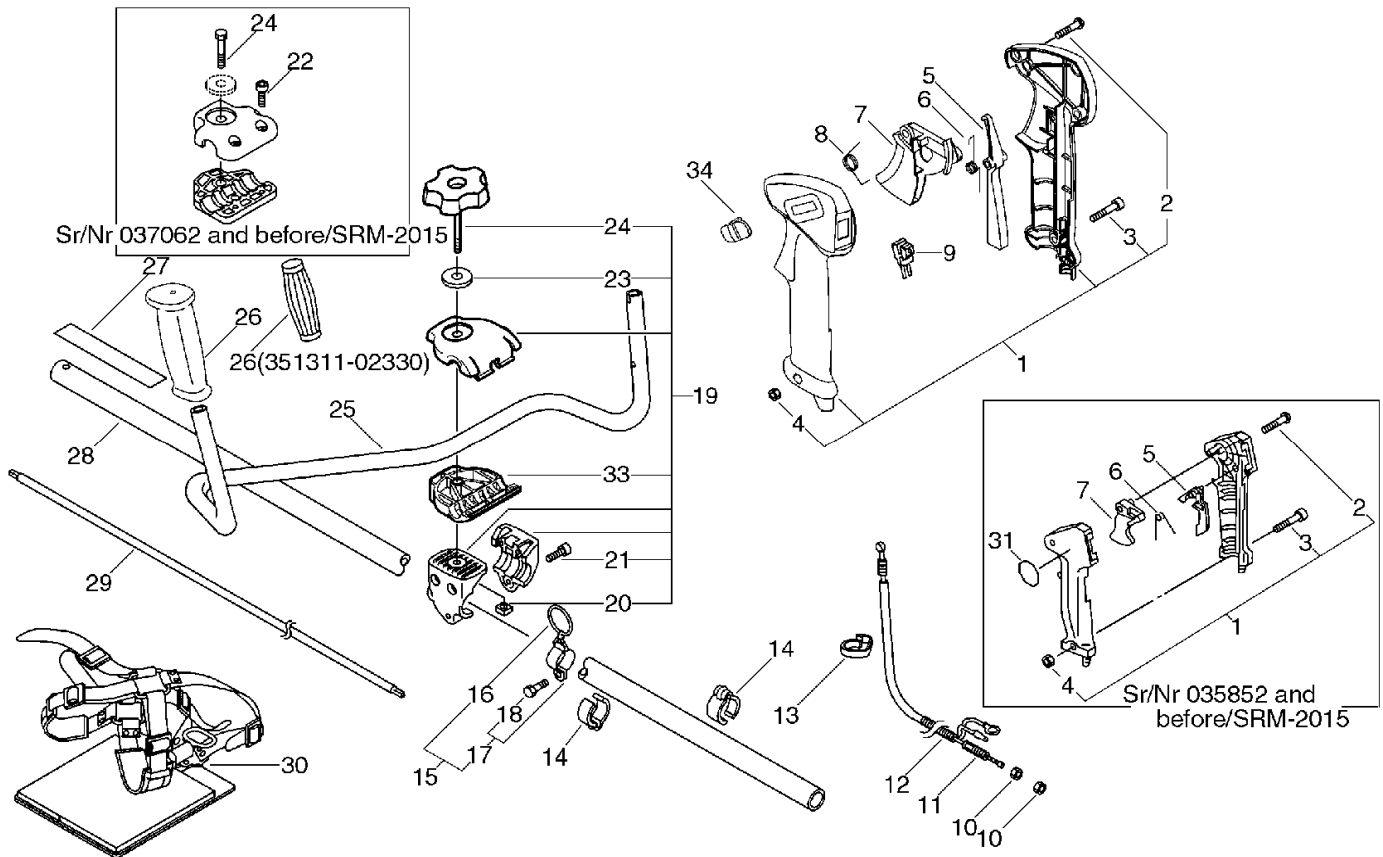

KEY	LV	PART NUMBER	Q'TY	DESCRIPTION	REMARKS	NOTE1	NOTE2
1		351102-47530	1	GRIP ASSY, F-HANDLE		Sr/Nr 035852 and before/SRM-2015	
1		P021-002610	1	GRIP ASY,F-HANDLE		Sr/Nr 035853 and after/SRM-2015 Sus. by P021-002612	
1		P021-002610	1	GRIP ASY,F-HANDLE		SRM-2015SI Sus. by P021-002612	
1		P021-002611	1	GRIP ASY,F-HANDLE		SRM-2015SI Sus. by P021-002612	
1		P021-002612	1	GRIP ASY,F-HANDLE			
2	+	900246-03025	4	SCREW 3*25	3*25	Sr/Nr 035852 and before/SRM-2015	
2	+	900246-04016	3	SCREW 4*16	4*16	Sus. by 900253-04016	
2	+	900253-04016	3	SCREW 4*16	4*16	Sr/Nr 035853 and after/SRM-2015	
2	+	900253-04016	3	SCREW 4*16	4*16	SRM-2015SI	
3	+	900220-05030	1	SCREW 5*30	5*30		
4	+	900500-00005	1	NUT 5	5		

9. U-Handle

No.9

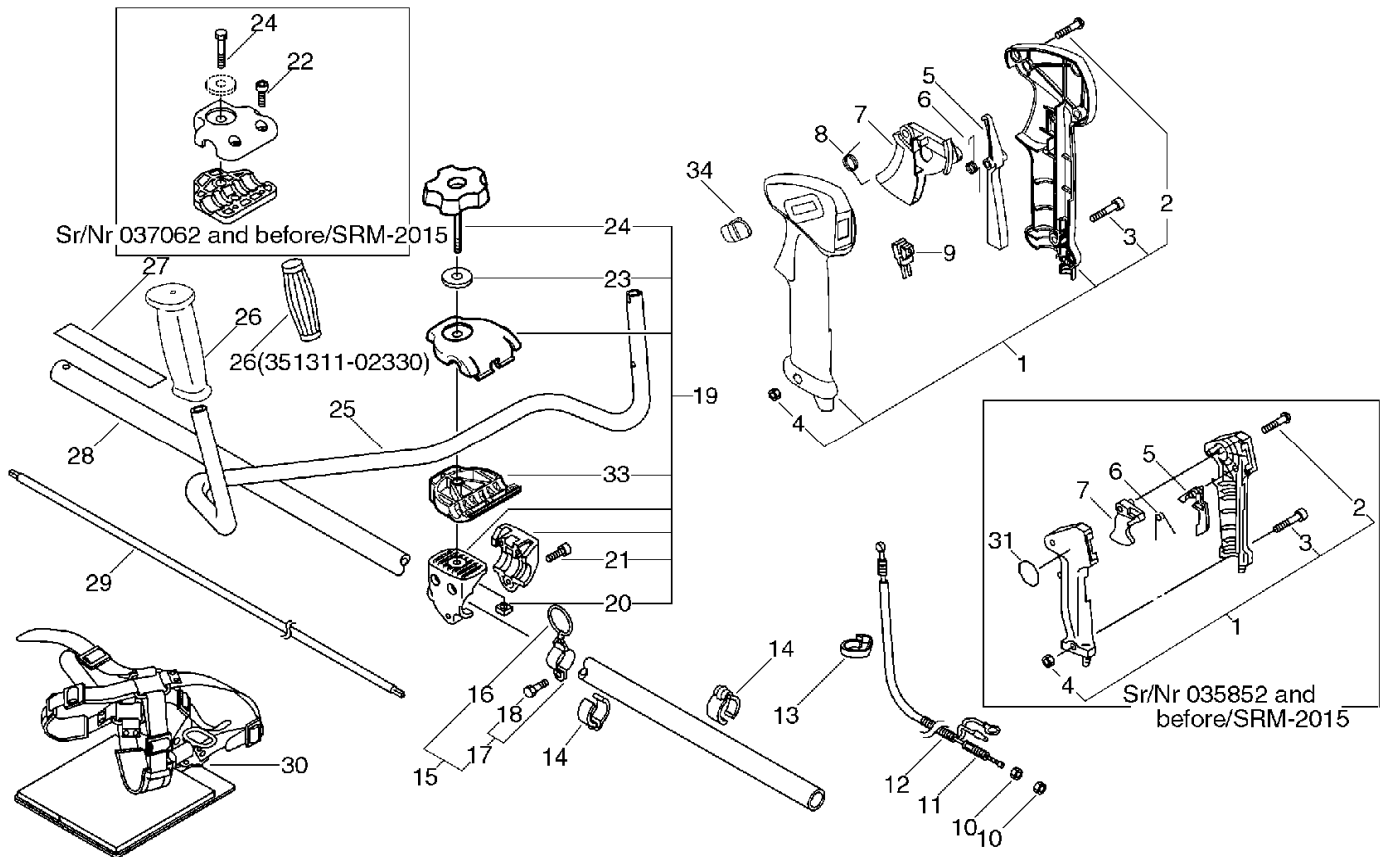

KEY	LV	PART NUMBER	Q'TY	DESCRIPTION	REMARKS	NOTE1	NOTE2
5		178012-05960	1	LOCKOUT, THROTTLE		Sr/Nr 035852 and before/SRM-2015	
5		C460-000010	1	LOCKOUT, THROTTLE		Sr/Nr 035853 and after/SRM-2015	
5		C460-000010	1	LOCKOUT, THROTTLE		Sus. by C460-000011	
5		C460-000011	1	LOCKOUT, THROTTLE		SRM-2015SI	
6		178013-35631	1	SPRING, THR. LOCK		Sr/Nr 035852 and before/SRM-2015	
6		V452-000050	1	SPRING, TORSION		Sr/Nr 035853 to 048224/SRM-2015	
6		V452-000050	1	SPRING, TORSION		Sr/Nr 35007346 and before/SRM-2015SI	
6		V452-000130	1	SPRING, TORSION		Sr/Nr 048225 and after/SRM-2015	
6		V452-000130	1	SPRING, TORSION		Sr/Nr 35007347 and after/SRM-2015SI	

9. U-Handle

No.9

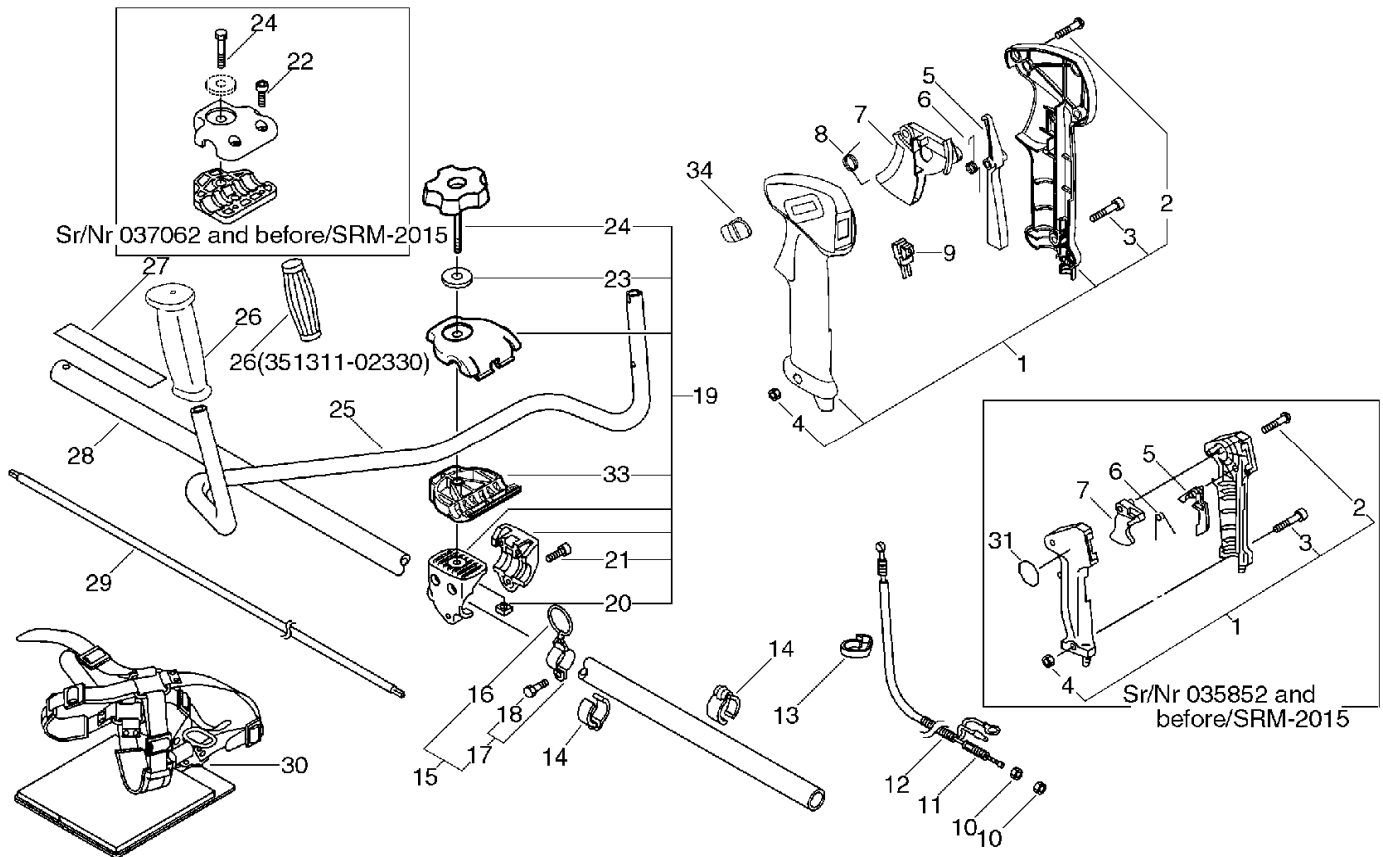

KEY	LV	PART NUMBER	Q'TY	DESCRIPTION	REMARKS	NOTE1	NOTE2
7		178010-05960	1	CONTROL, THROTTLE		Sr/Nr 035852 and before/SRM-2015	
7		C450-000020	1	TRIGGER, THROTTLE		Sr/Nr 035853 and after/SRM-2015 Sus. by C450-000022	
7		C450-000020	1	TRIGGER, THROTTLE		SRM-2015SI Sus. by C450-000022	
7		C450-000021	1	TRIGGER, THROTTLE		Sus. by C450-000022	
7		C450-000022	1	TRIGGER, THROTTLE			
8		V452-000060	1	SPRING, TORSION		Sr/Nr 035853 and after/SRM-2015	
8		V452-000060	1	SPRING, TORSION		SRM-2015SI	
9		163401-49230	1	SWITCH, IGNITION			
10		900502-00006	2	NUT 6 (3N)	3N6		
11		178001-47530	1	WIRE, THROTTLE		Sr/Nr 035852 and before/SRM-2015	
11		V430-000410	1	CABLE, BOWDEN		Sr/Nr 035853 and after/SRM-2015	
11		V430-000410	1	CABLE, BOWDEN		SRM-2015SI	

9. U-Handle

No.9

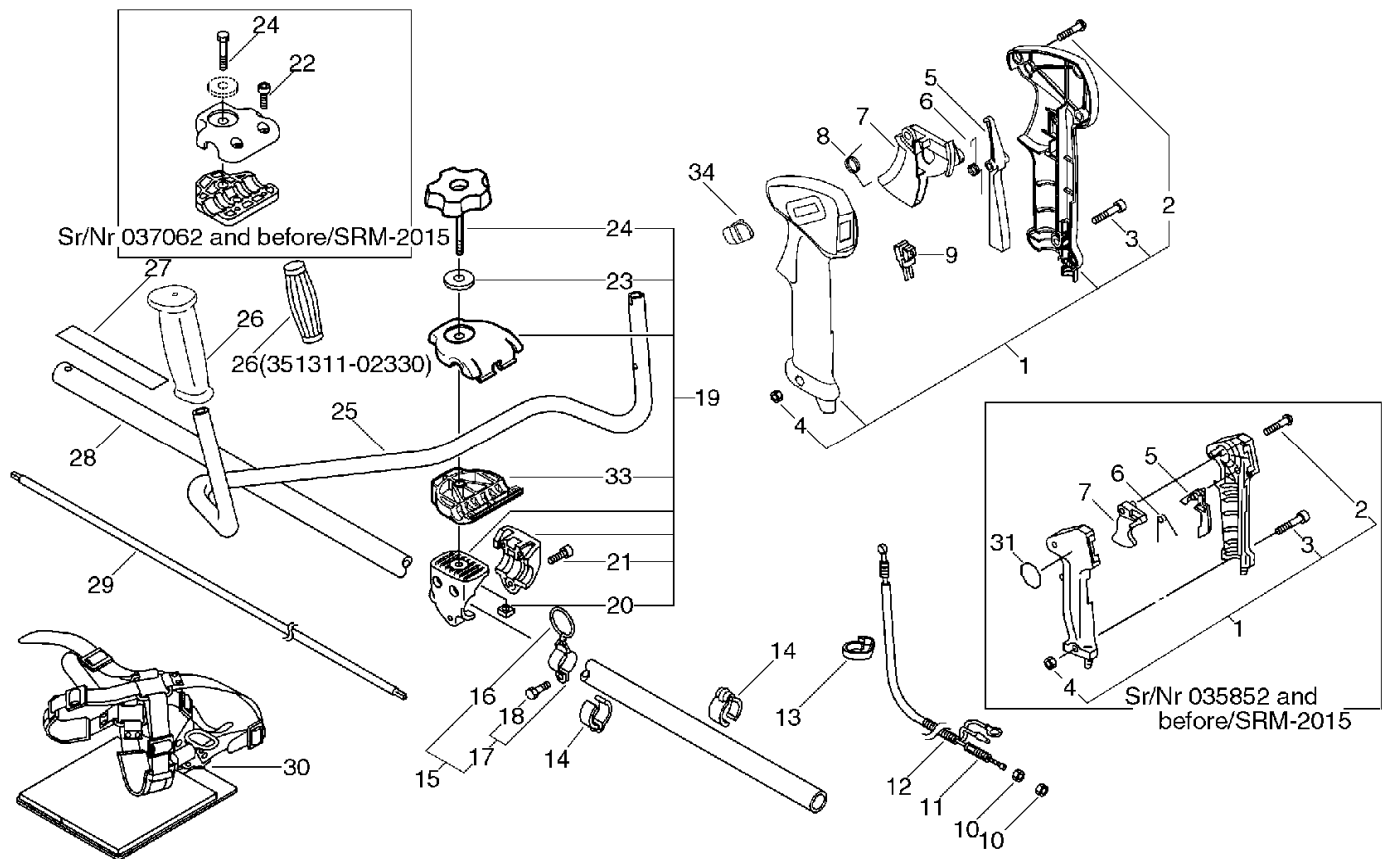

KEY	LV	PART NUMBER	Q'TY	DESCRIPTION	REMARKS	NOTE1	NOTE2
12		178127-47530	1	TUBE	7*10*760		
13		159112-09960	1	CLIP		Sus. by 159112-09961	
13		159112-09961	1	CLIP			
14		224924-52130	2	CLIP	25MM		
15		301200-21330	1	HOOK ASS'Y			
16	+	301015-05330	1	HOOK, BAND			
17	+	301205-21330	1	HOOK			
18	++	900105-05012	1	BOLT, H.S. 5*12	5*12		
19		351301-52130	1	BRACKET ASSY, HANDLE		Sr/Nr 037062 and before/SRM-2015	
19		P021-002750	1	BRACKET ASY, HANDLE		Sr/Nr 037063 and after/SRM-2015	
19		P021-002750	1	BRACKET ASY, HANDLE		Sus. by P021-002751	
19		P021-002751	1	BRACKET ASY, HANDLE		SRM-2015SI	
20	+	900565-50008	1	NUT	8*1.25		
21	+	900162-05030	3	BOLT, H.S. 5*30	5*30 W,SW		
22	+	900162-05020	2	BOLT, H.S. 5*20	5*20 W,SW	Sr/Nr 037062 and before/SRM-2015	
23	+	605014-54230	1	WASHER			

9. U-Handle

No.9

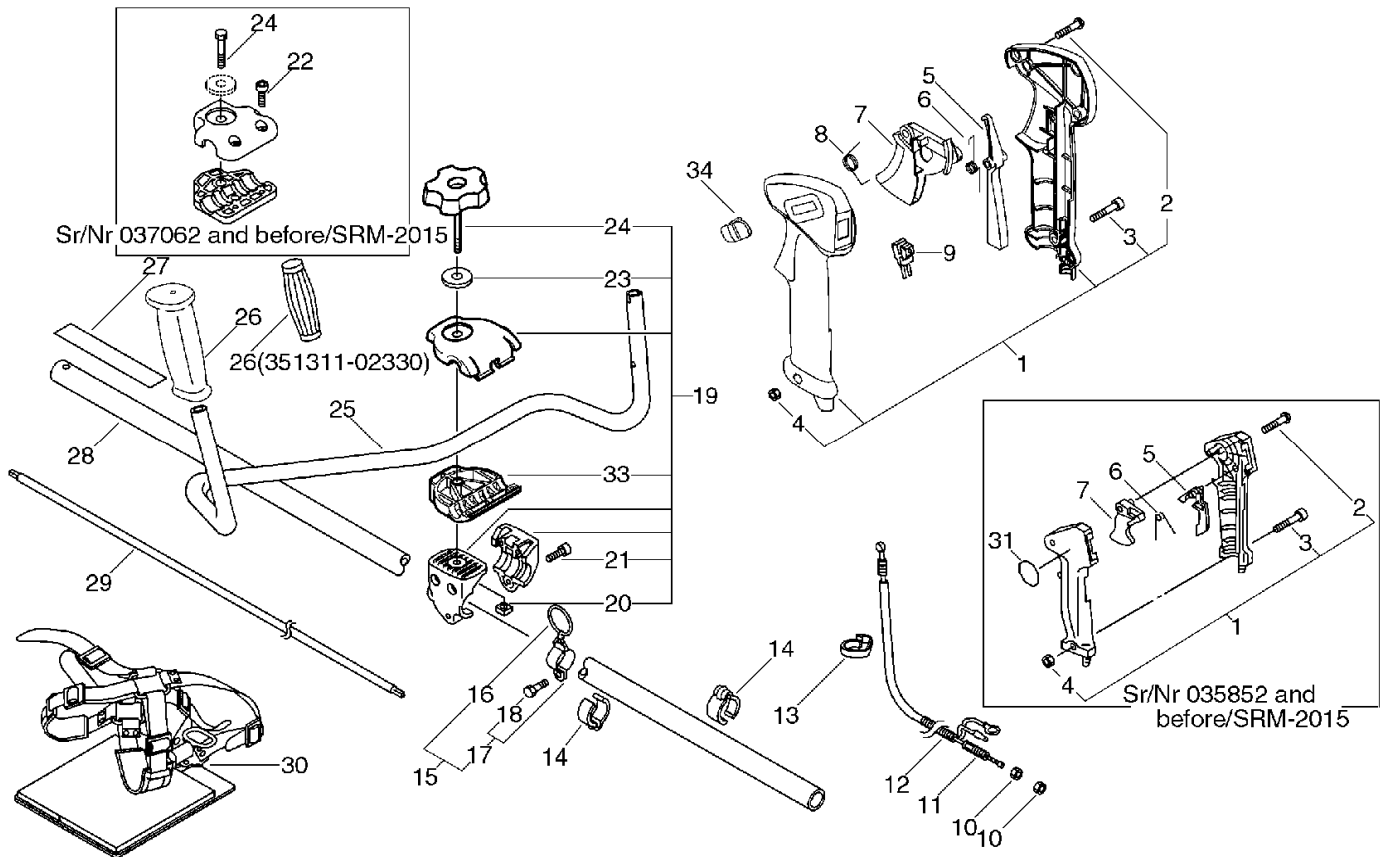

KEY	LV	PART NUMBER	Q'TY	DESCRIPTION	REMARKS	NOTE1	NOTE2
24	+	351421-52130	1	BOLT		Sr/Nr 037062 and before/SRM-2015	
24	+	V299-000110	1	KNOB,FASTENER		Sr/Nr 037063 and after/SRM-2015	
24	+	V299-000110	1	KNOB,FASTENER		SRM-2015SI	
33	+	C423-000041	1	FIXTURE,HANDLE			
25		351214-52130	1	HANDLE, FRONT		Sus. by C400-000000	
25		C400-000000	1	HANDLE,FRONT			
26		351311-02330	1	GRIP, HANDLE		Sr/Nr 035852 and before/SRM-2015	
26		C403-000030	1	GRIP,HANDLE		Sus. by C403-000031	
26		C403-000031	1	GRIP,HANDLE		Sr/Nr 035853 and after/SRM-2015	
26		C403-000030	1	GRIP,HANDLE		Sus. by C403-000031	
26		C403-000031	1	GRIP,HANDLE		SRM-2015SI	
27		890617-46830	1	LABEL, CAUTION		Sus. by 890617-43130	
27		890617-43130	1	LABEL,CAUTION			
28		610206-28230	1	HOUSING ASS'Y D,SFT.			

9. U-Handle

No.9

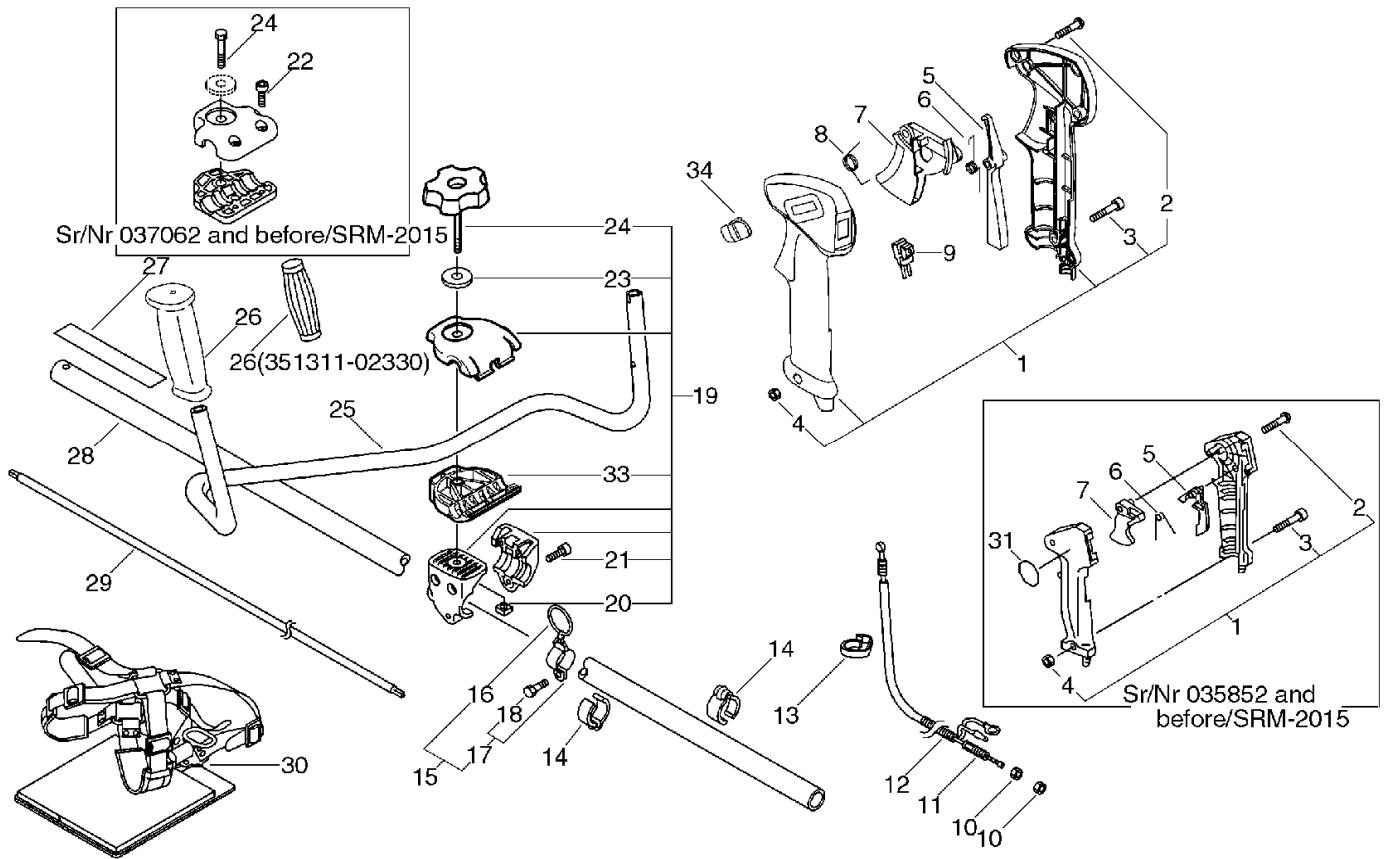

KEY	LV	PART NUMBER	Q'TY	DESCRIPTION	REMARKS	NOTE1	NOTE2
29		610018-27830	1	SHAFT, DRIVE			
30		301001-56830	1	HARNESS, SHOULDER		Sus. by 301001-56831	
30		301001-56831	1	HARNESS ASY, SHOULDER			
31		890157-39130	1	LABEL, SWITCH		Sr/Nr 035852 and before/SRM-2015	
34		C463-000000	1	KNOB, LATCH		Sr/Nr 048225 and after/SRM-2015	
34		C463-000000	1	KNOB, LATCH		Sr/Nr 35007347 and after/SRM-2015SI	

10. Gear Case(U-Handle Type), Blade No.10

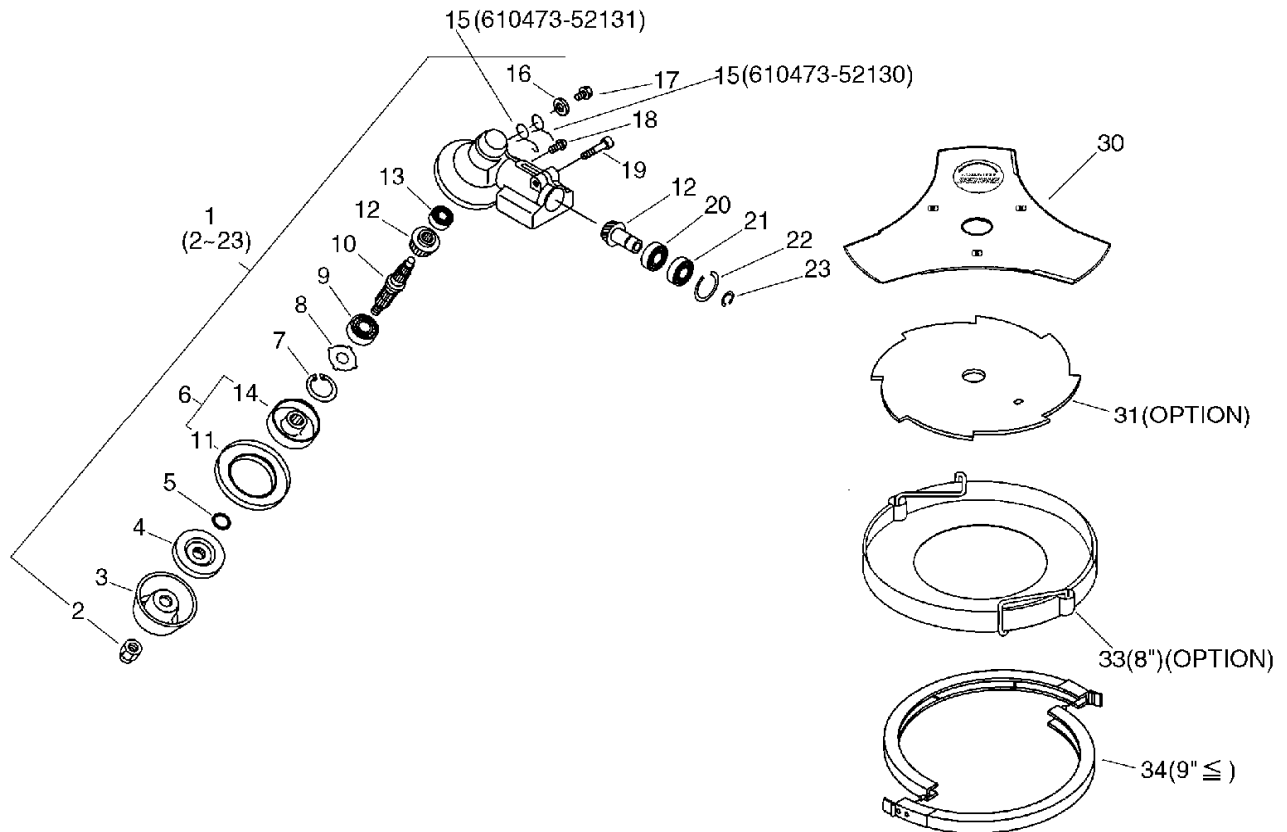

KEY	LV	PART NUMBER	Q'TY	DESCRIPTION	REMARKS	NOTE1	NOTE2
1		610400-56830	1	HOUSING ASSY, GEAR		Sus. by 610400-56832	
1		610400-56831	1	CASE ASY, GEAR		Sus. by 610400-56832	
1		610400-56832	1	CASE ASY, GEAR			
2	+	610320-52130	1	NUT 10			
3	+	699229-56830	1	PLATE, COVER			
4	+	610314-52130	1	PLATE, ADAPTER (L)			
5	+	900720-00012	1	O-RING 12	P-12		
6	+	610313-52930	1	PLATE, ADAPTER (U)		Sus. by C535-000001	
6	+	C535-000000	1	FIXTURE, BLADE		Sus. by C535-000001	
6	+	C535-000001	1	FIXTURE, BLADE			
11	++	610352-56830	1	PLATE, CUP			
14	++	C535-000010	1	FIXTURE, BLADE		Sus. by C535-000011	
14	++	C535-000011	1	FIXTURE, BLADE			
7	+	900702-00032	1	CIRCLIP 32	CR-32		
8	+	610444-56830	1	WASHER			
9	+	900812-06201	1	BEARING, BALL 6201	6201DDU(LLU)		
10	+	610310-56830	1	SHAFT, P.T.O.			
12	+	610300-40830	1	GEAR SET			
13	+	900810-00626	1	BEARING, BALL 626	626		

10. Gear Case(U-Handle Type), Blade No.10

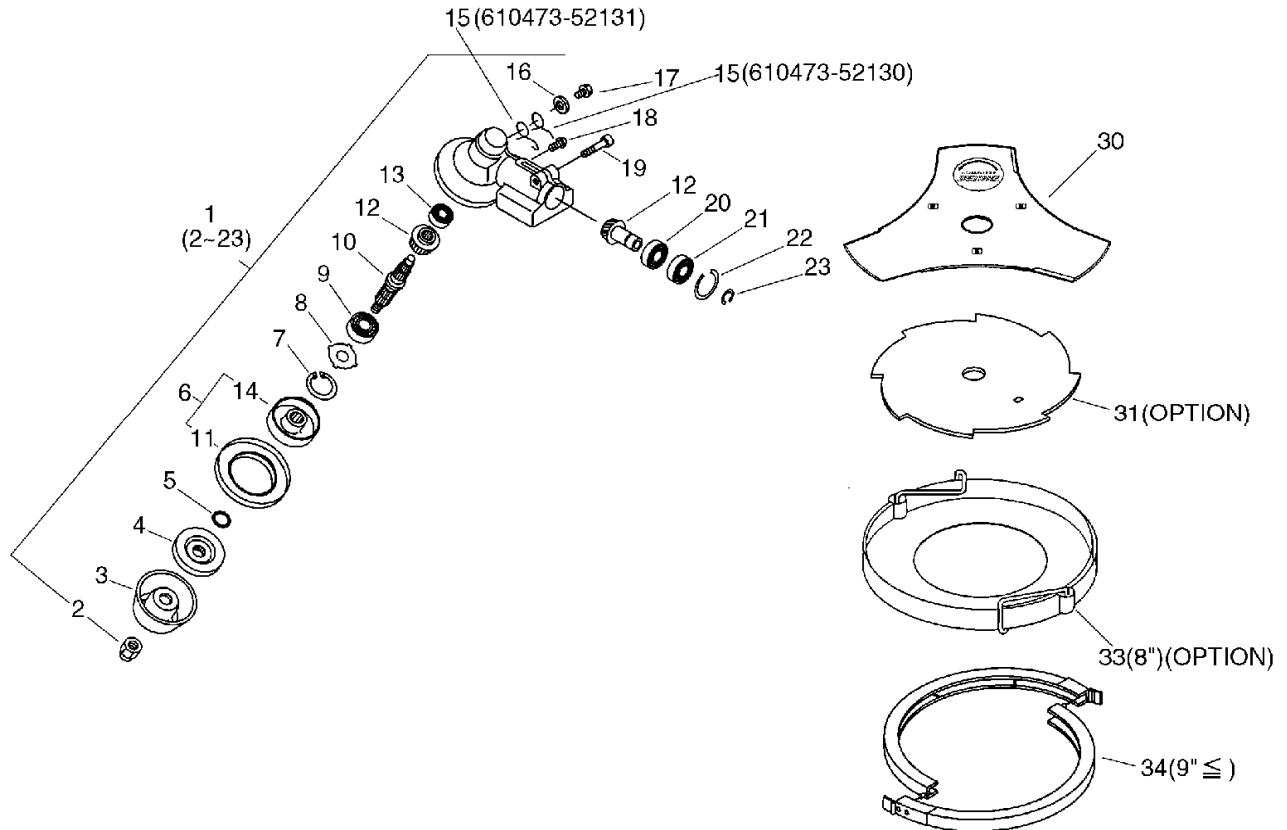

KEY	LV	PART NUMBER	Q'TY	DESCRIPTION	REMARKS	NOTE1	NOTE2
15	+	610473-52130	1	SPRING, TORSION		Can be used on the 610313-52930 only/SRM-2015	
15	+	610473-52131	1	SPRING		Can be used on the C535- 000000,000001 /SRM-2015 SRM-2015SI	
16	+	900603-50008	1	WASHER	8.5*18*0.8T		
17	+	610434-50030	1	BOLT 8* 6		Sus. by 610434- 50031	
17	+	610434-50031	1	BOLT 8* 8	M8*8		
18	+	900242-05010	1	SCREW 5*10	5*10		
19	+	900162-06025	1	BOLT, H.S. 6*25	6*25 W,SW		
20	+	900855-06900	1	BEARING, BALL 6900	6900		
21	+	900858-06900	1	BEARING, BALL 6900Z	6900Z		
22	+	900702-00022	1	CIRCLIP 22	CR-22		
23	+	900706-00010	1	CIRCLIP 10	WR-10		
30		X405-000010	1	SAW,BUSH CUTTER	3*230*25.4*T2.0	Sus. by X405- 000011	
30		X405-000011	1	SAW,BUSH CUTTER	3*230*25.4*T2.0		
34		898523-47130	1	SCABBARD, BLADE		Sus. by P021- 007470	
34		P021-007470	1	SCABBARD, BLADE			

10. Gear Case(U-Handle Type), Blade
No.10

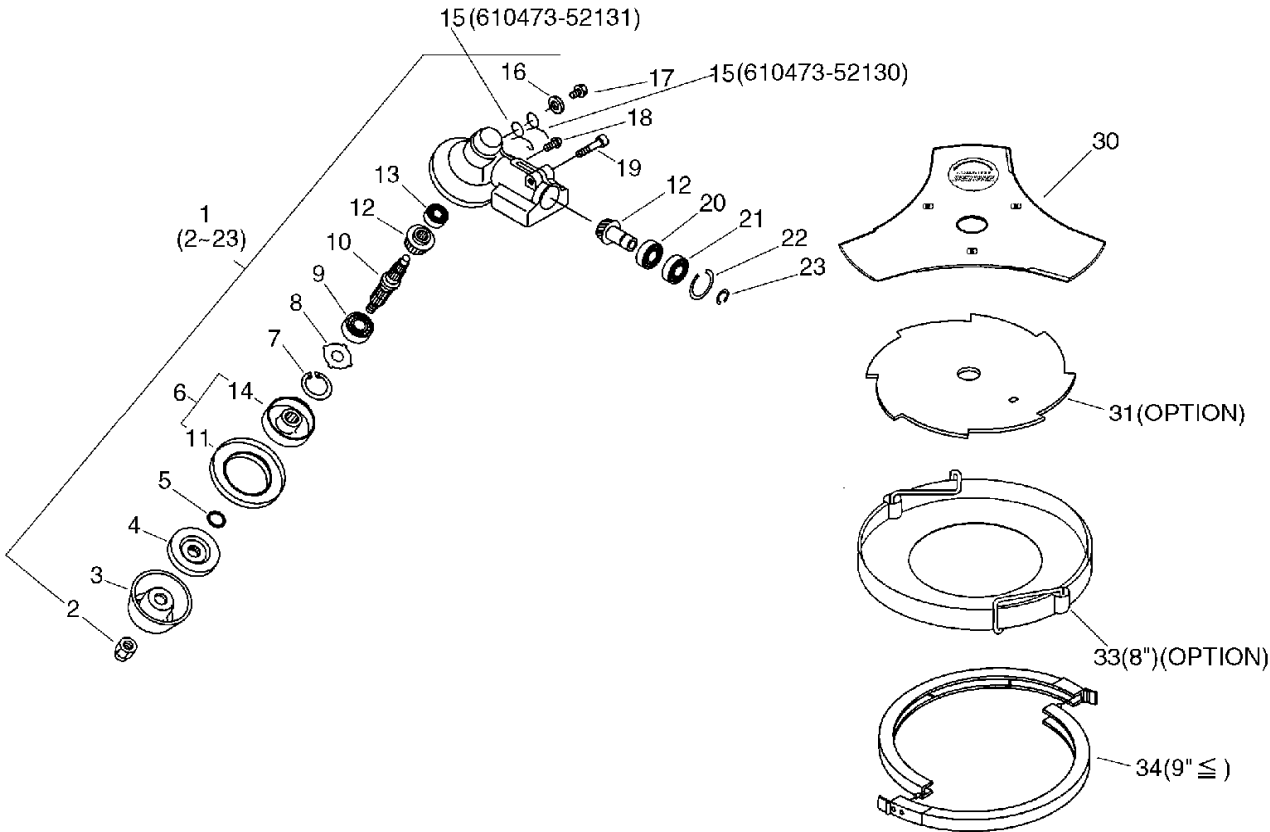

KEY	LV	PART NUMBER	Q'TY	DESCRIPTION	REMARKS	NOTE1	NOTE2
31		696001-48030	1	BLADE, 8-CUTTER		Sus. by 696001-48031	
31		696001-48031	1	BLADE, 8-CUTTER	200*8P*1.8 PD25	OPTION	
33		898503-08030	1	COVER SET, CUTTER		OPTION	

11. Loop Handle

No.11

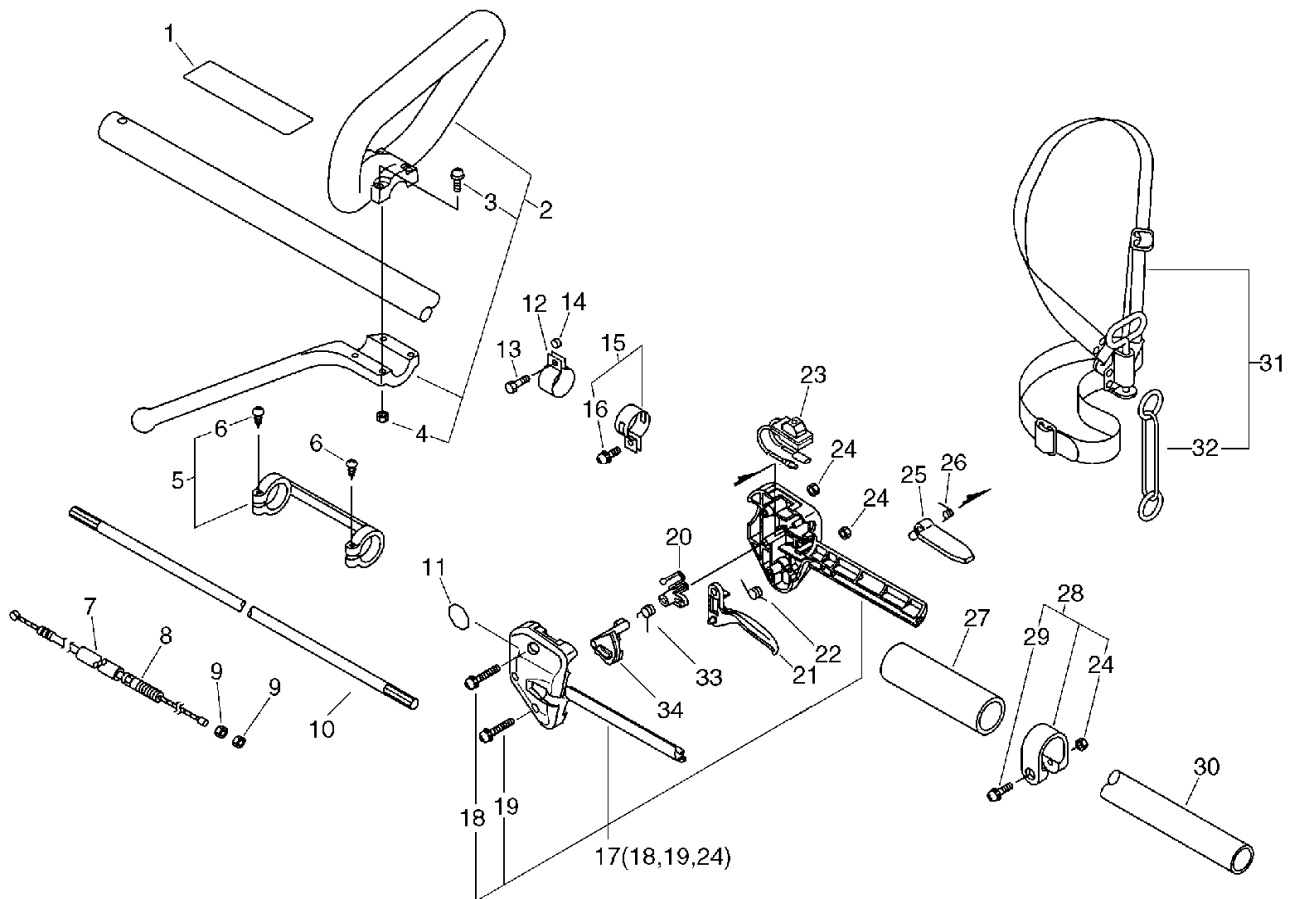

KEY	LV	PART NUMBER	Q'TY	DESCRIPTION	REMARKS	NOTE1	NOTE2
1		890177-46730	1	LABEL, CAUTION			Sus. by 890617-43130
1		890617-63630	1	LABEL, CAUTION			Sus. by 890617-43130
1		X505-000140	1	LABEL, CAUTION			Sus. by 890617-43130
1		890617-43130	1	LABEL, CAUTION			
2		351201-54130	1	HANDLE ASSY, LOOP			
3	+	900242-05035	4	SCREW 5*35	5*35		
4	+	900500-00005	4	NUT 5	5		
5		610281-54130	1	COLLER			
6	+	900253-04025	2	SCREW 4*25	4*25		
7		178127-54530	1	TUBE 7*10*130	7*10*130		
8		178001-51030	1	WIRE, THROTTLE			
9		900502-00006	2	NUT 6 (3N)	3N6		
10		610018-27830	1	SHAFT, DRIVE			
11		890157-39130	1	LABEL, SWITCH			Sr/Nr 047934 and before/SRM-2015
11		890157-39130	1	LABEL, SWITCH			Sr/Nr 35007352 and before/SRM-2015SI
12		301207-08930	1	HOOK			
13		900100-05018	1	BOLT 5*18	5*18		
14		699012-03330	1	SPACER			
15		301200-29430	1	BAND ASSY			

11. Loop Handle

No.11

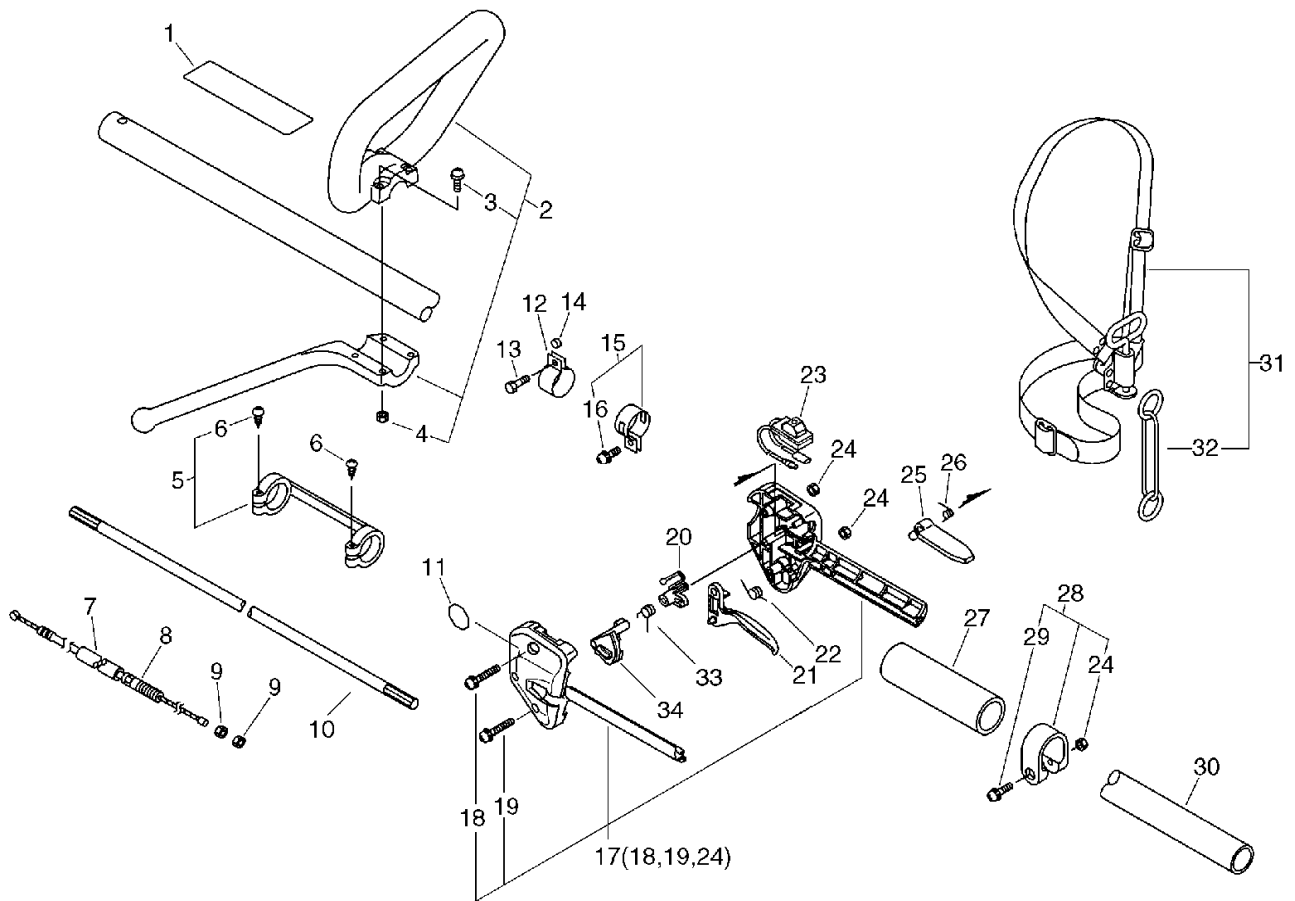

KEY	LV	PART NUMBER	Q'TY	DESCRIPTION	REMARKS	NOTE1	NOTE2
16	+	900242-05014	1	SCREW 5*14	5*14		
17		178003-52130	1	BRACKET SET,THROTTLE		Sr/Nr 047934 and before/SRM-2015	
17		178003-52130	1	BRACKET SET,THROTTLE		Sr/Nr 35007352 and before/SRM-2015SI	
17		P021-005850	1	BRACKET SET,THROTTLE		Sr/Nr 047935 and after/SRM-2015	
17		P021-005850	1	BRACKET SET,THROTTLE		Sr/Nr 35007353 and after/SRM-2015SI	
18	+	900242-05035	1	SCREW 5*35	5*35		
19	+	900242-05025	1	SCREW 5*25	5*25		
24	+	900500-00005	2	NUT 5	5		
20		178012-52630	1	LOCKOUT, THROTTLE		Sr/Nr 047934 and before/SRM-2015	
20		178012-52630	1	LOCKOUT, THROTTLE		Sr/Nr 35007352 and before/SRM-2015SI	
20		C461-000000	1	LATCH,THROTTLE		Sr/Nr 047935 and after/SRM-2015	

11. Loop Handle

No.11

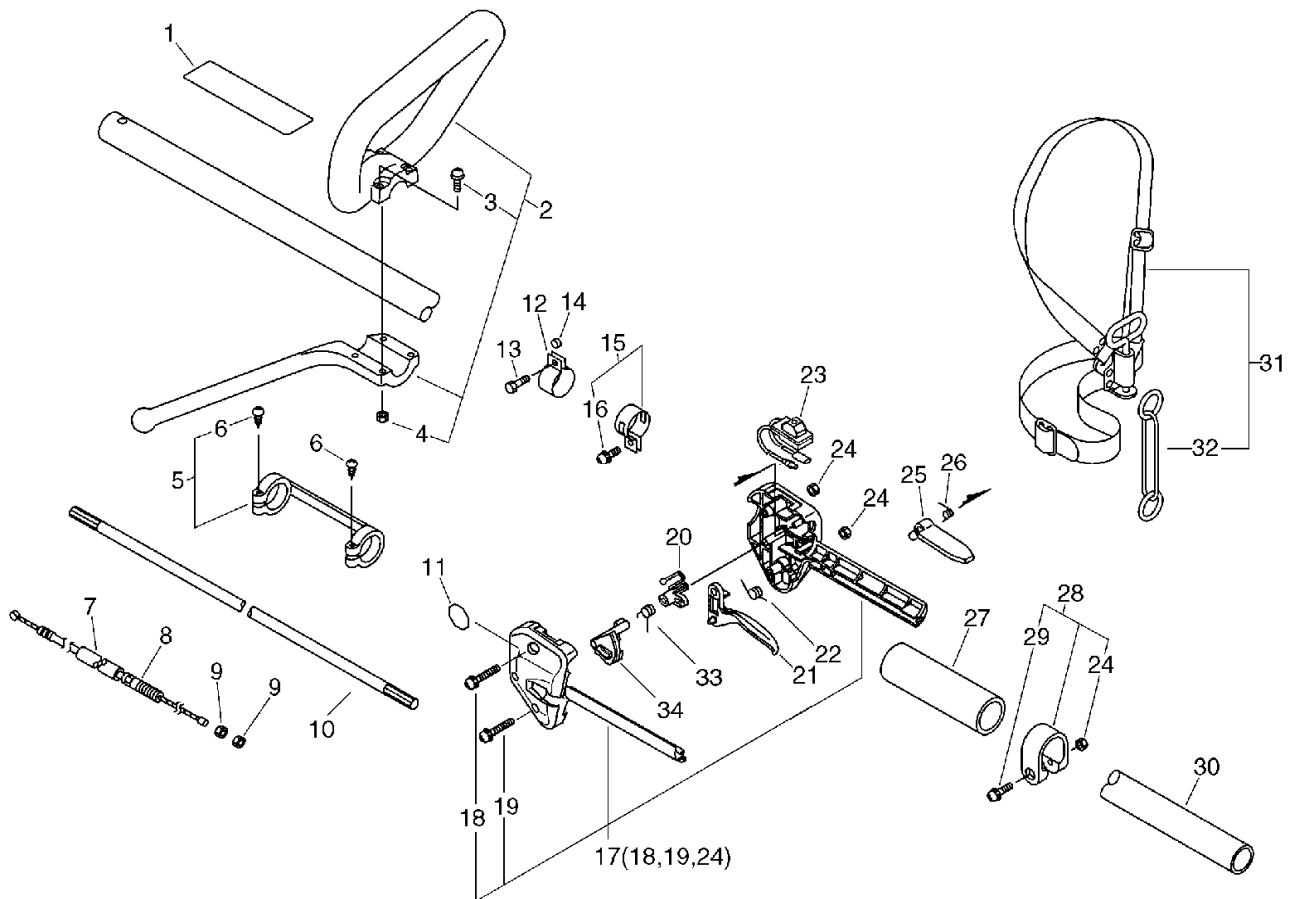

KEY	LV	PART NUMBER	Q'TY	DESCRIPTION	REMARKS	NOTE1	NOTE2
20		C461-000000	1	LATCH, THROTTLE		Sr/Nr 35007353 and after/SRM-2015SI	
21		178010-52130	1	CONTROL, THROTTLE		Sr/Nr 047934 and before/SRM-2015	
21		178010-52130	1	CONTROL, THROTTLE		Sr/Nr 35007352 and before/SRM-2015SI	
21		C450-000110	1	TRIGGER, THROTTLE		Sr/Nr 047935 and after/SRM-2015	
21		C450-000110	1	TRIGGER, THROTTLE		Sr/Nr 35007353 and after/SRM-2015SI	
22		178043-42230	1	SPRING, THR. RETURN			
23		163400-49230	1	SWITCH, IGNITION			
25		178090-52630	1	LOCKOUT, T. CONTROL		Sus. by 178090-52632	
25		178090-52631	1	LOCKOUT, T. CONTROL		Sus. by 178090-52632	
25		178090-52632	1	LOCKOUT, T. CONTROL			
26		178013-52630	1	SPRING, THR. LOCK			
27		351213-52130	1	GRIP		Sus. by C403-000140	
27		C403-000140	1	GRIP, HANDLE	L129.5*28		

11. Loop Handle

No.11

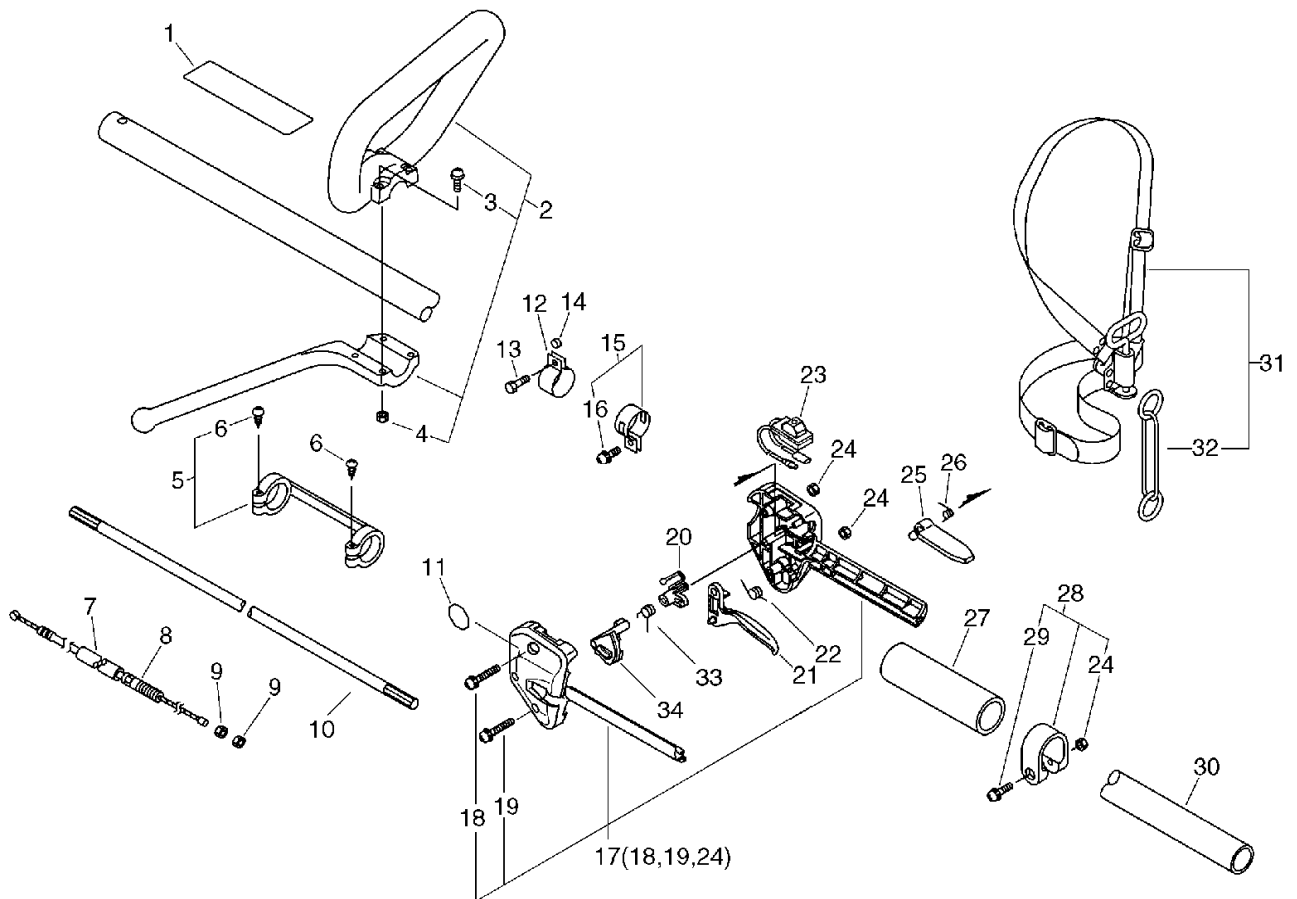

KEY	LV	PART NUMBER	Q'TY	DESCRIPTION	REMARKS	NOTE1	NOTE2
28		610272-52130	1	BAND			
24	+	900500-00005	1	NUT 5	5		
29	+	900242-05028	1	SCREW 5*28	5*28		
30		610206-28230	1	HOUSING ASSY D,SFT.			
31		301000-55230	1	HARNESS ASSY		Sus. by 301000-55231	
31		301000-55231	1	HARNESS ASY,SHOULDER			
32	+	301305-24330	1	LINK			
33		V452-000120	1	SPRING,TORSION		Sr/Nr 047935 and after/SRM-2015	
33		V452-000120	1	SPRING,TORSION		Sr/Nr 35007353 and after/SRM-2015SI	
34		C461-000010	1	LATCH,THROTTLE		Sr/Nr 047935 and after/SRM-2015	
34		C461-000010	1	LATCH,THROTTLE		Sr/Nr 35007353 and after/SRM-2015SI	

12. Gear Case(Loop Handle Type), Nylon Line Cutting Head

No.12

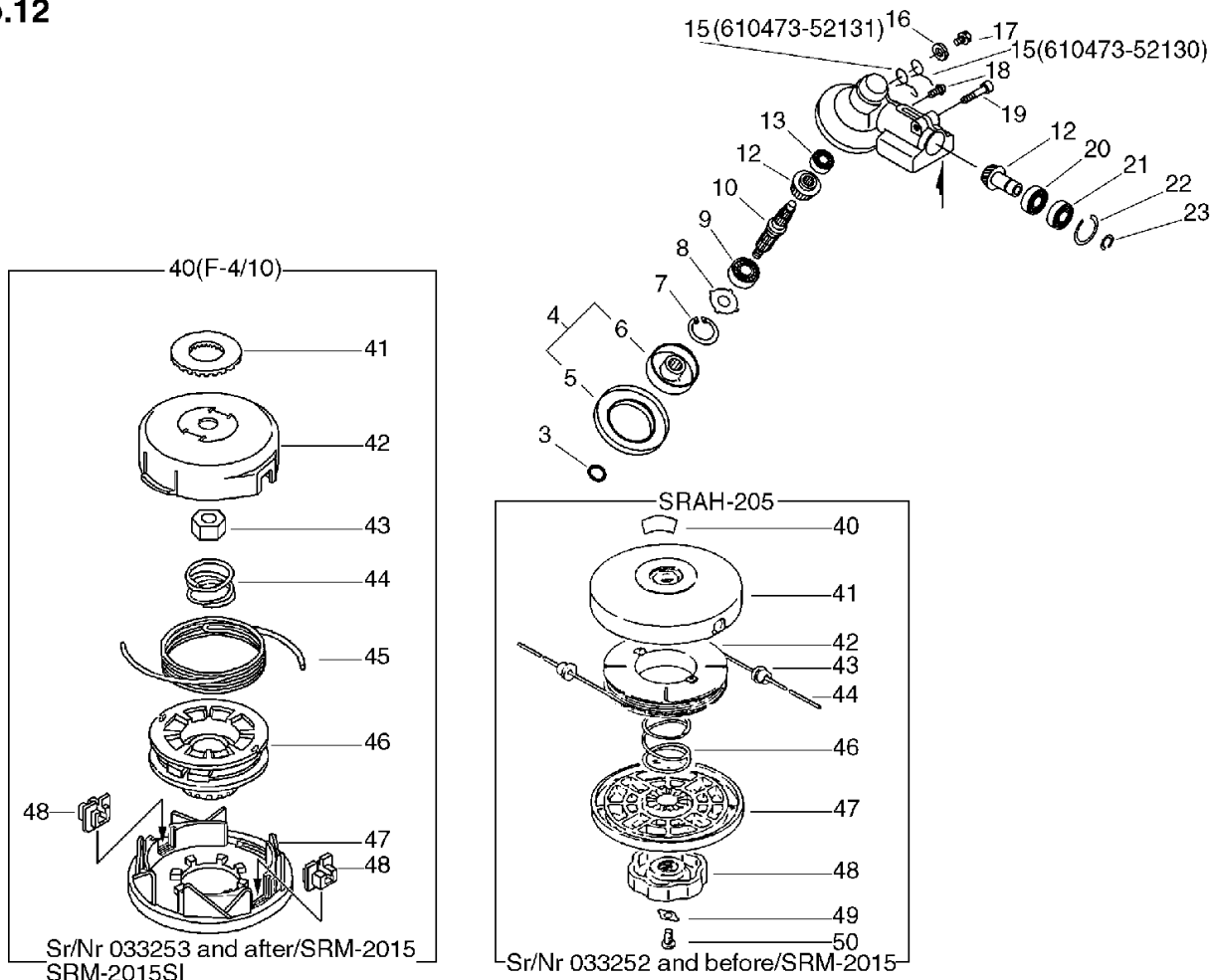

KEY	LV	PART NUMBER	Q'TY	DESCRIPTION	REMARKS	NOTE1	NOTE2
3		900720-00012	1	O-RING 12	P-12		
4		610313-52930	1	PLATE, ADAPTER (U)		Sus. by C535-000001	
4		C535-000000	1	FIXTURE, BLADE		Sus. by C535-000001	
4		C535-000001	1	FIXTURE, BLADE			
5	+	610352-56830	1	PLATE, CUP			
6	+	C535-000010	1	FIXTURE, BLADE		Sus. by C535-000011	
6	+	C535-000011	1	FIXTURE, BLADE			
7		900702-00032	1	CIRCLIP 32	CR-32		
8		610444-56830	1	WASHER			
9		900812-06201	1	BEARING, BALL 6201	6201DDU(LLU)		
10		610310-56830	1	SHAFT, P.T.O.			
12		610300-40830	1	GEAR SET			
13		900810-00626	1	BEARING, BALL 626	626		
15		610473-52130	1	SPRING, TORSION		Can be used on the 610313-52930 only/SRM-2015	
15		610473-52131	1	SPRING		Can be used on the C535-000000,000001 /SRM-2015	
15		610473-52131	1	SPRING		SRM-2015SI	
16		900603-50008	1	WASHER	8.5*18*0.8T		

12. Gear Case(Loop Handle Type), Nylon Line Cutting Head

No.12

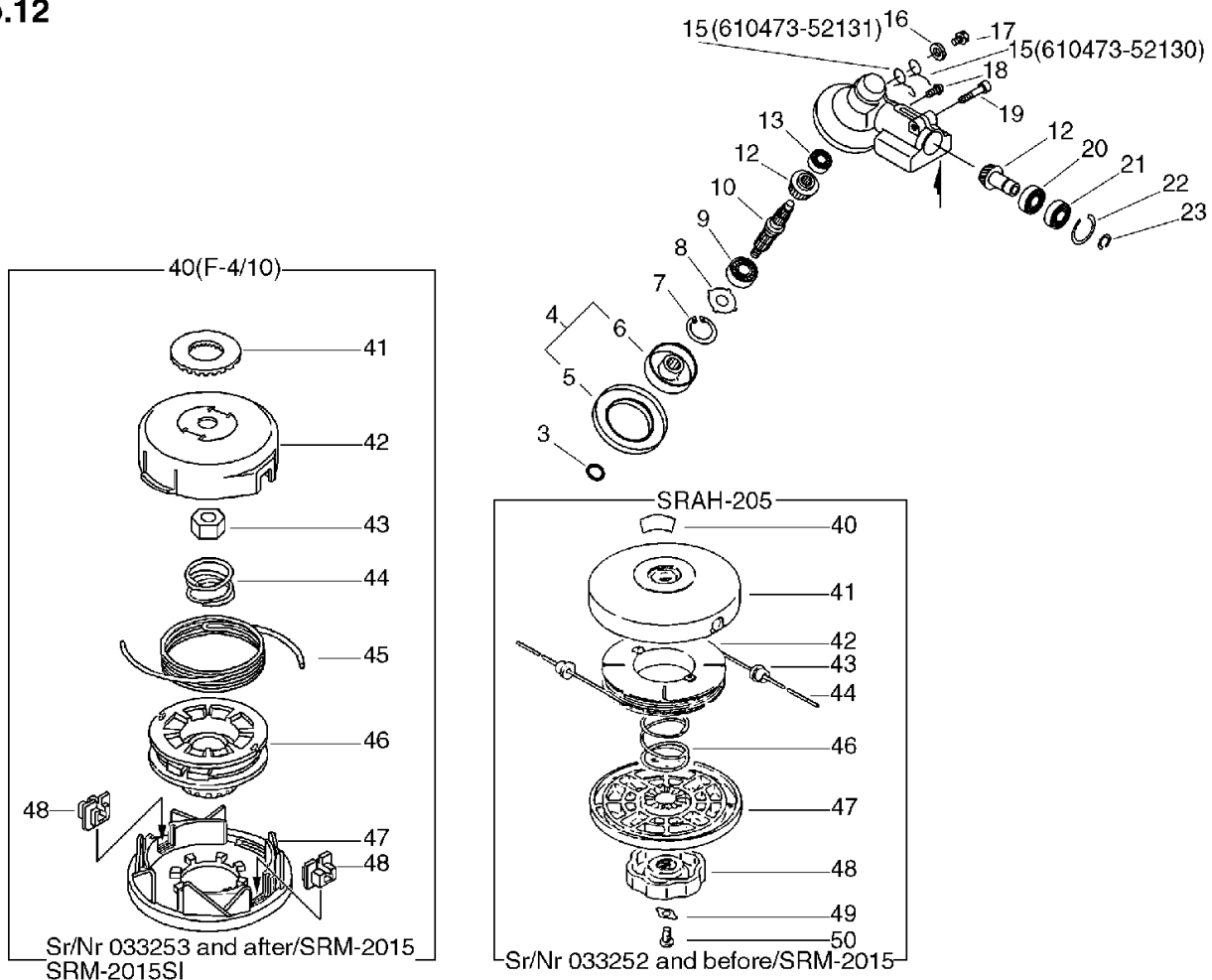

KEY	LV	PART NUMBER	Q'TY	DESCRIPTION	REMARKS	NOTE1	NOTE2
17		610434-50030	1	BOLT 8*6		Sus. by 610434-50031	
17		610434-50031	1	BOLT 8*8	M8*8		
18		900242-05010	1	SCREW 5*10	5*10		
19		900162-06025	1	BOLT, H.S. 6*25	6*25 W,SW		
20		900855-06900	1	BEARING, BALL 6900	6900		
21		900858-06900	1	BEARING, BALL 6900Z	6900Z		
22		900702-00022	1	CIRCLIP 22	CR-22		
23		900706-00010	1	CIRCLIP 10	WR-10		
40		890617-46730	1	LABEL, CAUTION		Sr/Nr 033252 and before/SRM-2015	
41		696210-56930	1	DRUM, REEL		Sr/Nr 033252 and before/SRM-2015	
42		696214-06830	1	REEL, CORD		Sr/Nr 033252 and before/SRM-2015	
43		696212-06032	2	EYELET		Sr/Nr 033252 and before/SRM-2015	
44		696215-22830	2	CORD, NYLON(2.4*2.5)		Sr/Nr 033252 and before/SRM-2015	

12. Gear Case(Loop Handle Type), Nylon Line Cutting Head

No.12

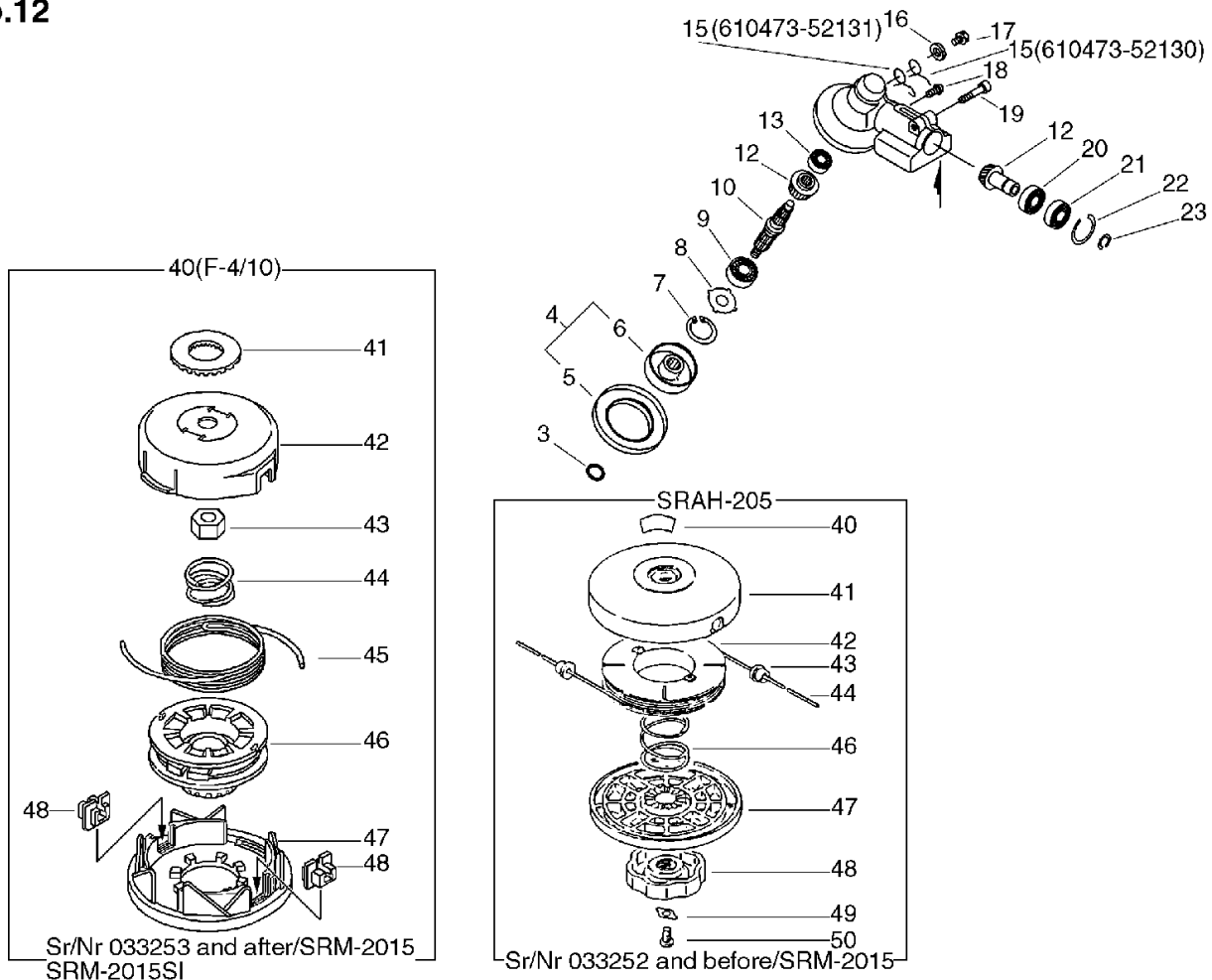

KEY	LV	PART NUMBER	Q'TY	DESCRIPTION	REMARKS	NOTE1	NOTE2
46		696216-06030	1	SPRING		Sr/Nr 033252 and before/SRM-2015	
47		696206-28232	1	COVER, DRUM (BL)		Sr/Nr 033252 and before/SRM-2015	
48		696219-28231	1	NUT (BL)		Sr/Nr 033252 and before/SRM-2015	
49		696220-06030	1	STOPPER, NUT		Sr/Nr 033252 and before/SRM-2015	
50		900220-06010	1	SCREW 6*10	6*10	Sr/Nr 033252 and before/SRM-2015	
40		X047-000050	1	CUTTER,ASM LINE	DS-3/10	Sus. by X047-000260	
40		X047-000150	1	CUTTER,ASM LINE	F4/10 M10L	Sus. by X047-000260	
40		X047-000151	1	CUTTER,ASM LINE	F4/10 M10L	Sus. by X047-000260	
40		X047-000260	1	CUTTER,ASM LINE	F4/10 M10L	Sr/Nr 033253 and after	
41	+	V332-000000	1	WASHER,CIRCULAR 24		Sr/Nr 033253 and after/SRM-2015	

12. Gear Case(Loop Handle Type), Nylon Line Cutting Head

No.12

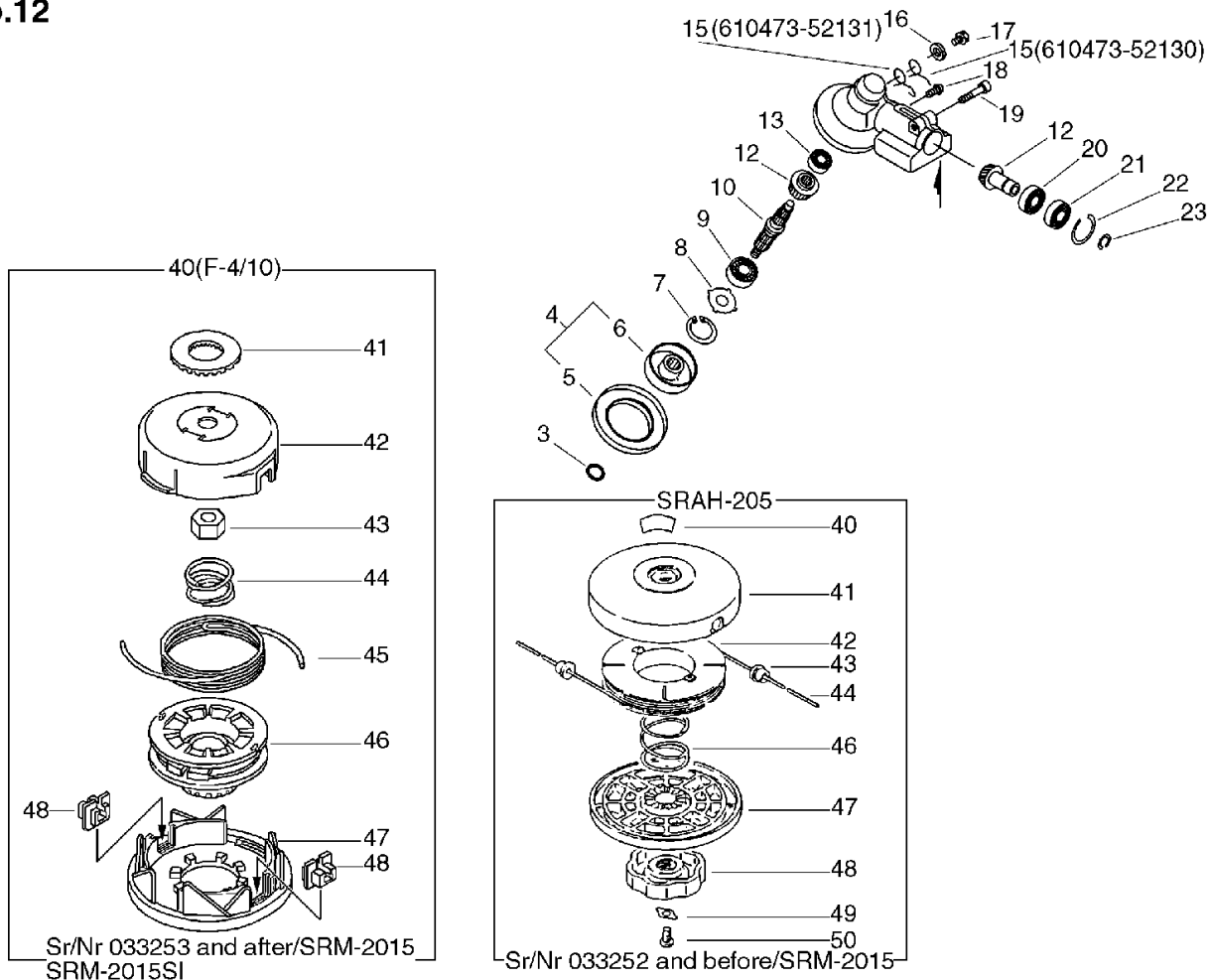

KEY	LV	PART NUMBER	Q'TY	DESCRIPTION	REMARKS	NOTE1	NOTE2
41	+	V332-000000	1	WASHER,CIRCULAR 24		SRM-2015SI	
42	+	X470-000020	1	DRUM,REEL		Sus. by P022-003310	
42	+	P022-002890	1	HOUSING		Sus. by P022-003310	
42	+	P022-003310	1	HOUSING		Sr/Nr 033253 and after/SRM-2015	
42	+	P022-003310	1	HOUSING		SRM-2015SI	
43	+	P022-001220	1	NUT		Sr/Nr 033253 and after/SRM-2015	
43	+	P022-001220	1	NUT		SRM-2015SI	
44	+	P022-001250	1	SPRING	DS-3/10	Sr/Nr 033253 and after/SRM-2015	
44	+	P022-001250	1	SPRING	DS-3/10	SRM-2015SI	
45	+	P022-001230	1	NYLON CODE		Sus. by P022-006190	
45	+	P022-006190	1	NYLON CODE	3.0*2M	Sr/Nr 033253 and after	
46	+	P022-001260	1	BOBBIN	DS-3/10	Sr/Nr 033253 and after/SRM-2015	
46	+	P022-001260	1	BOBBIN	DS-3/10	SRM-2015SI	

12. Gear Case(Loop Handle Type), Nylon Line Cutting Head

No.12

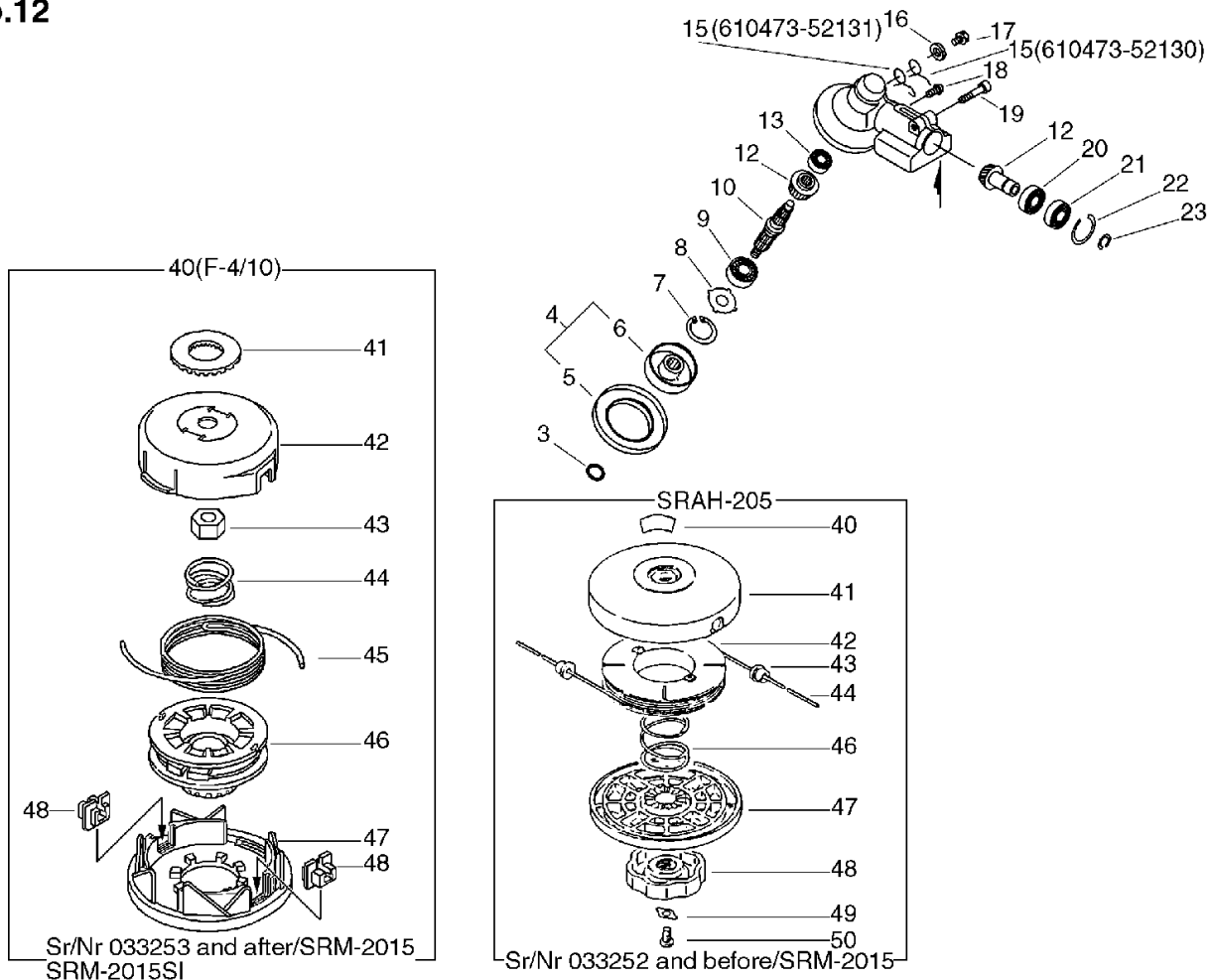

KEY	LV	PART NUMBER	Q'TY	DESCRIPTION	REMARKS	NOTE1	NOTE2
47	+	P022-001240	1	COVER	DS-3/10	Sus. by P022-003330	
47	+	P022-002860	1	COVER		Sus. by P022-003330	
47	+	P022-003330	1	COVER		Sr/Nr 033253 and after/SRM-2015	
47	+	P022-003330	1	COVER		SRM-2015SI	
48	+	P022-000710	2	EYELET	T4	Sr/Nr 033253 and after/SRM-2015	
48	+	P022-000710	2	EYELET	T4	SRM-2015SI	

13. Carburetor

No.13

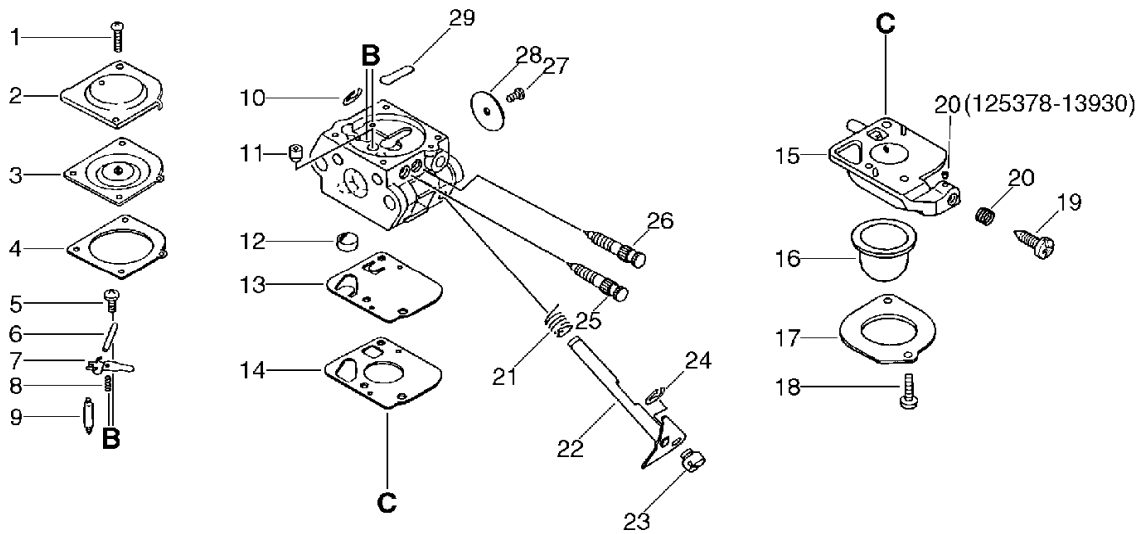

KEY	LV	PART NUMBER	Q'TY	DESCRIPTION	REMARKS	NOTE1	NOTE2
		125200-52430	1	CARBURETOR ASSY	C1U-K53	Sus. by 125200-52433	
		125200-52431	1	CARBURETOR	C1U-K53	Sus. by 125200-52433	
		125200-52432	1	CARBURETOR	C1U-K53A	Sus. by 125200-52433	
		125200-52433	1	CARBURETOR	C1U-K53B		
1	+	125344-52130	2	SCREW			
2	+	125342-13210	1	COVER, DIAPHRAGM		Sus. by 125342-52130	
2	+	125342-52130	1	COVER, DIAPHRAGM			
3	+	125341-49030	1	DIAPHRAGM			
4	+	125340-51030	1	GASKET, DIAPHRAGM			
5	+	125339-42030	1	SCREW			
6	+	125338-13930	1	PIN, METERING ARM			
7	+	125323-42030	1	LEVER, METERING			
8	+	125322-42030	1	SPRING, COIL		Sus. by 125322-11520	
8	+	125322-11520	1	SPRING, COIL			
9	+	125337-06960	1	VALVE, INLET NEEDLE			
10	+	125327-15130	1	CLIP			
11	+	125376-49030	1	NOZZLE, CHACK VALVE		Sus. by P005-001050	
11	+	P005-001050	1	NOZZLE, CHECK VALVE			
12	+	125326-42030	1	STRAINER			
13	+	125312-12820	1	DIAPHRAGM, FUEL PUMP			

13. Carburetor

No.13

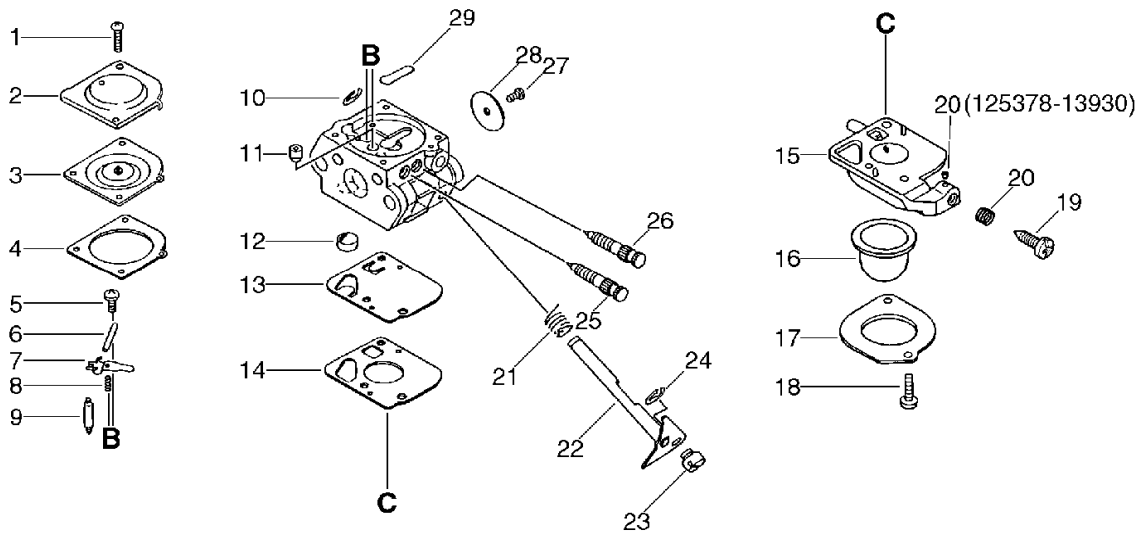

KEY	LV	PART NUMBER	Q'TY	DESCRIPTION	REMARKS	NOTE1	NOTE2
14	+	125325-13310	1	GASKET, PUMP			
15	+	125324-11610	1	COVER, PUMP		Sus. by P005-000590	
15	+	125383-13310	1	BASE, PRIMER		Sus. by P005-000590	
15	+	P005-000590	1	BASE,ASY PRIMER			
16	+	125381-08660	1	PUMP, PRIMING			
17	+	125363-11610	1	RING			
18	+	125310-11610	2	SCREW			
19	+	125334-13930	1	SCREW, IDLE ADJUST		Sr/Nr 012002 and before/SRM-2015	
19	+	125334-06960	1	SCREW, THROTTLE ADJUST		Sr/Nr 012003 and after /SRM-2015	
19	+	125334-06960	1	SCREW, THROTTLE ADJUST		SRM-2015SI	
20	+	125378-13930	1	PIECE, FRICTION		Sr/Nr 012002 and before/SRM-2015	
20	+	125333-06960	1	SPRING, IDLE ADJUSTER		Sr/Nr 012003 and after /SRM-2015	
20	+	125333-06960	1	SPRING, IDLE ADJUSTER		SRM-2015SI	
21	+	125313-42030	1	SPRING, THRT. RETURN			
22	+	125317-49030	1	SHAFT, THROTTLE		Sus. by P005-000390	

13. Carburetor

No.13

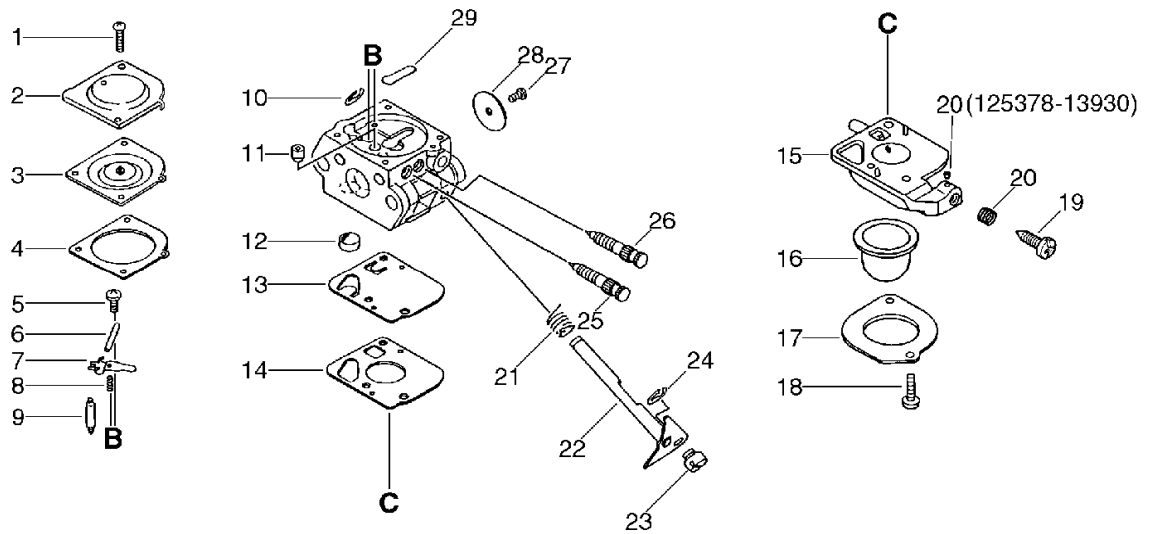

KEY	LV	PART NUMBER	Q'TY	DESCRIPTION	REMARKS	NOTE1	NOTE2
22	+	P005-000390	1	SHAFT, THROTTLE			
23	+	125372-42030	1	SWIVEL			
24	+	125327-13930	1	CLIP			
25	+	125320-52430	1	NEEDLE, HIGH SPEED		Can be used on 125200- 52431,52432	
25	+	P005-001710	1	SCREW,MAINN MIXTURE		Can be used on 125200-52433	
26	+	125318-52430	1	NEEDLE, IDLE			
27	+	125314-13930	1	SCREW	3*4		
28	+	125316-49030	1	VALVE, THROTTLE			
29	+	125345-15130	1	PLUG, WELCH			

14. Repair Kit

KEY	LV	PART NUMBER	Q'TY	DESCRIPTION	REMARKS	NOTE1	NOTE2
		125303-13310	1	DIAPHRAGM/GASKET KIT			
10-3	+	125341-49030	1	DIAPHRAGM			
10-4	+	125340-51030	1	GASKET, DIAPHRAGM			
10-13	+	125312-12820	1	DIAPHRAGM, FUEL PUMP			
10-14	+	125325-13310	1	GASKET, PUMP			
		125300-13310	1	REBUILD KIT		Sus. by P005-001810	
		P005-001810	1	REBUILD KIT			
10-3	+	125341-49030	1	DIAPHRAGM			
10-4	+	125340-51030	1	GASKET, DIAPHRAGM			
10-6	+	125338-13930	1	PIN, METERING ARM			
10-7	+	125323-42030	1	LEVER, METERING			
10-8	+	125322-42030	1	SPRING, COIL		Sus. by 125322-11520	
10-8	+	125322-11520	1	SPRING, COIL			
10-9	+	125337-06960	1	VALVE, INLET NEEDLE			
10-12	+	125326-42030	1	STRAINER			
10-13	+	125312-12820	1	DIAPHRAGM, FUEL PUMP			
10-14	+	125325-13310	1	GASKET, PUMP			
10-29	+	125345-15130	1	PLUG, WELCH			

Index

Patrs Number	Key No.	Patrs Number	Key No.	Patrs Number	Key No.
100000-48730	1 - 4	125323-42030	13 - 7	131205-07320	6 - 12
100000-48731	1 - 4	125323-42030	14 - 10- 7	131300-56430	6 - 7
100000-48732	1 - 4	125324-11610	13 - 15	131312-44330	6 - 9
100011-05330	1 - 5	125325-13310	13 - 14	132010-13930	6 - 14
100012-51230	1 - 10	125325-13310	14 - 10-14	132010-56330	6 - 13
100013-11520	1 - 6	125325-13310	14 - 10-14	132013-09820	6 - 11
100014-11520	1 - 8	125326-42030	13 - 12	132115-46730	6 - 10
100015-04630	1 - 7	125326-42030	14 - 10-12	145510-42031	5 - 22
100100-44732	1 - 9	125327-13930	13 - 24	145631-42030	5 - 29
100100-44733	1 - 9	125327-15130	13 - 10	145642-04930	5 - 28
100100-54130	1 - 9	125333-06960	13 - 20	145863-42030	5 - 24
100204-52130	1 - 11	125333-06960	13 - 20	145866-42031	5 - 23
100204-52131	1 - 11	125334-06960	13 - 19	145876-42030	5 - 25
100204-52132	1 - 11	125334-06960	13 - 19	150112-42030	2 - 14
100212-42030	1 - 12	125334-13930	13 - 19	156601-52130	2 - 8
100212-42031	1 - 12	125337-06960	13 - 9	156801-12360	2 - 7
100215-03930	1 - 13	125337-06960	14 - 10- 9	156801-44731	2 - 7
100242-42030	1 - 15	125338-13930	13 - 6	156801-44731	2 - 7
101010-44332	1 - 3	125338-13930	14 - 10- 6	159010-10230	2 - 13
101011-06560	1 - 1	125339-42030	13 - 5	159011-03432	2 - 12
101011-06561	1 - 1	125340-51030	13 - 4	159012-01620	2 - 11
101011-06562	1 - 1	125340-51030	14 - 10- 4	159017-10230	2 - 13
101511-44630	1 - 19	125340-51030	14 - 10- 4	159112-09960	9 - 13
101514-42031	1 - 17	125341-49030	13 - 3	159112-09961	9 - 13
101514-44731	1 - 17	125341-49030	14 - 10- 3	162010-52830	2 - 10
125200-52430	13 -	125341-49030	14 - 10- 3	162021-52130	2 - 10
125200-52430	5 - 6	125342-13210	13 - 2	163400-49230	11 - 23
125200-52431	13 -	125342-52130	13 - 2	163401-49230	9 - 9
125200-52431	5 - 6	125344-52130	13 - 1	175000-52130	2 - 6
125200-52432	13 -	125345-15130	13 - 29	175000-52131	2 - 6
125200-52432	5 - 6	125345-15130	14 - 10-29	175005-46730	2 - 5
125200-52433	13 -	125363-11610	13 - 17	175053-04920	2 - 1
125200-52433	5 - 6	125372-42030	13 - 23	177200-42033	3 - 24
125300-13310	14 -	125376-49030	13 - 11	177202-44330	3 - 21
125303-13310	14 -	125378-13930	13 - 20	177202-44331	3 - 21
125310-11610	13 - 18	125381-08660	13 - 16	177215-44430	3 - 26
125312-12820	13 - 13	125383-13310	13 - 15	177218-44330	3 - 23
125312-12820	14 - 10-13	130010-42032	5 - 1	177220-42030	3 - 30
125312-12820	14 - 10-13	130016-42031	5 - 5	177226-10120	3 - 27
125313-42030	13 - 21	130017-42031	5 - 4	177227-42030	3 - 28
125314-13930	13 - 27	130111-00530	6 - 8	177228-06530	3 - 29
125316-49030	13 - 28	130301-42030	5 - 8	177228-27030	4 - 21
125317-49030	13 - 22	130310-46730	5 - 13	177234-42030	3 - 22
125318-52430	13 - 26	130319-42030	5 - 7	177234-42030	4 - 42
125320-52430	13 - 25	131004-55530	6 - 4	177236-44330	3 - 25
125322-11520	13 - 8	131005-44331	6 - 1	177246-11120	4 - 20
125322-11520	14 - 10- 8	131005-44332	6 - 1	178001-47530	9 - 11
125322-42030	13 - 8	131016-55830	6 - 5	178001-51030	11 - 8
125322-42030	14 - 10- 8	131051-56030	6 - 6	178003-52130	11 - 17

Index

Patrs Number	Key No.	Patrs Number	Key No.	Patrs Number	Key No.
178003-52130	11 - 17	610313-52930	10 - 6	890617-43130	11 - 1
178010-05960	9 - 7	610313-52930	12 - 4	890617-43130	9 - 27
178010-52130	11 - 21	610314-52130	10 - 4	890617-46730	12 - 40
178010-52130	11 - 21	610320-52130	10 - 2	890617-46830	9 - 27
178012-05960	9 - 5	610352-56830	10 - 11	890617-63630	11 - 1
178012-52630	11 - 20	610352-56830	12 - 5	895112-00330	8 - 2
178012-52630	11 - 20	610400-56830	10 - 1	895410-08030	8 - 3
178013-35631	9 - 6	610400-56831	10 - 1	895610-00130	8 - 1
178013-52630	11 - 26	610400-56832	10 - 1	897518-01131	8 - 4
178043-42230	11 - 22	610434-50030	10 - 17	898503-08030	10 - 33
178090-52630	11 - 25	610434-50030	12 - 17	898510-39130	8 - 6
178090-52631	11 - 25	610434-50031	10 - 17	898523-47130	10 - 34
178090-52632	11 - 25	610434-50031	12 - 17	899580-40930	8 - 5
178127-47530	9 - 12	610444-56830	10 - 8	899580-68730	8 - 5
178127-54530	11 - 7	610444-56830	12 - 8	900100-05018	11 - 13
178515-42030	5 - 10	610473-52130	10 - 15	900105-05012	9 - 18
178515-46731	5 - 10	610473-52130	12 - 15	900105-05055	5 - 27
178516-00830	5 - 11	610473-52131	10 - 15	900151-05025	1 - 21
178810-42030	5 - 9	610473-52131	10 - 15	900162-04016	4 - 33
224924-52130	9 - 14	610473-52131	12 - 15	900162-04022	2 - 9
301000-55230	11 - 31	610473-52131	12 - 15	900162-05014	7 - 28
301000-55231	11 - 31	696001-48030	10 - 31	900162-05018	7 - 27
301001-56830	9 - 30	696001-48031	10 - 31	900162-05020	9 - 22
301001-56831	9 - 30	696206-28232	12 - 47	900162-05022	1 - 2
301015-05330	9 - 16	696210-56930	12 - 41	900162-05025	7 - 29
301200-21330	9 - 15	696212-06032	12 - 43	900162-05025	8 - 23
301200-29430	11 - 15	696214-06830	12 - 42	900162-05028	1 - 16
301205-21330	9 - 17	696215-22830	12 - 44	900162-05030	9 - 21
301207-08930	11 - 12	696216-06030	12 - 46	900162-06025	10 - 19
301305-24330	11 - 32	696219-28231	12 - 48	900162-06025	12 - 19
305110-42030	6 - 3	696220-06030	12 - 49	900220-05030	9 - 3
351102-47530	9 - 1	699000-52930	7 - 25	900220-06010	12 - 50
351201-54130	11 - 2	699000-52931	7 - 25	900238-04012	1 - 18
351213-52130	11 - 27	699010-52930	7 - 34	900238-04016	1 - 20
351214-52130	9 - 25	699010-52931	7 - 34	900238-04016	3 - 35
351301-52130	9 - 19	699012-03330	11 - 14	900238-04016	4 - 33
351311-02330	9 - 26	699013-52130	7 - 26	900238-05020	5 - 3
351421-52130	9 - 24	699013-56830	7 - 30	900242-04010	5 - 26
605014-54230	9 - 23	699013-56830	8 - 22	900242-05010	10 - 18
610018-27830	11 - 10	699016-52130	7 - 31	900242-05010	12 - 18
610018-27830	9 - 29	699016-54530	7 - 31	900242-05014	11 - 16
610206-28230	11 - 30	699229-56830	10 - 3	900242-05018	8 - 17
610206-28230	9 - 28	890118-49130	3 - 36	900242-05018	8 - 17
610272-52130	11 - 28	890157-39130	11 - 11	900242-05025	11 - 19
610281-54130	11 - 5	890157-39130	11 - 11	900242-05028	11 - 29
610300-40830	10 - 12	890157-39130	9 - 31	900242-05035	11 - 3
610300-40830	12 - 12	890169-47530	5 - 14	900242-05035	11 - 18
610310-56830	10 - 10	890177-46730	11 - 1	900242-05057	5 - 12
610310-56830	12 - 10	890611-46730	1 - 24	900243-05016	6 - 2

Index

Patrs Number	Key No.	Patrs Number	Key No.	Patrs Number	Key No.
900246-03025	9 - 2	A051-000292	4 - 19	P021-002610	9 - 1
900246-04016	9 - 2	A052-000130	4 - 40	P021-002611	9 - 1
900252-05012	8 - 13	A320-000250	5 - 29	P021-002612	9 - 1
900252-05012	8 - 13	A320-000251	5 - 29	P021-002620	8 - 10
900253-04016	9 - 2	C400-000000	9 - 25	P021-002620	8 - 10
900253-04016	9 - 2	C403-000030	9 - 26	P021-002750	9 - 19
900253-04025	11 - 6	C403-000030	9 - 26	P021-002750	9 - 19
900253-05020	4 - 15	C403-000031	9 - 26	P021-002751	9 - 19
900500-00005	11 - 4	C403-000031	9 - 26	P021-002861	8 - 5
900500-00005	11 - 24	C403-000140	11 - 27	P021-005850	11 - 17
900500-00005	11 - 24	C423-000041	9 - 33	P021-005850	11 - 17
900500-00005	5 - 2	C450-000020	9 - 7	P021-007470	10 - 34
900500-00005	7 - 33	C450-000020	9 - 7	P022-000710	12 - 48
900500-00005	9 - 4	C450-000021	9 - 7	P022-000710	12 - 48
900502-00006	11 - 9	C450-000022	9 - 7	P022-001220	12 - 43
900502-00006	9 - 10	C450-000110	11 - 21	P022-001220	12 - 43
900565-00005	8 - 16	C450-000110	11 - 21	P022-001230	12 - 45
900565-00005	8 - 16	C460-000010	9 - 5	P022-001240	12 - 47
900565-50008	9 - 20	C460-000010	9 - 5	P022-001250	12 - 44
900600-00005	1 - 23	C460-000011	9 - 5	P022-001250	12 - 44
900600-00005	5 - 28	C461-000000	11 - 20	P022-001260	12 - 46
900603-00005	7 - 32	C461-000000	11 - 20	P022-001260	12 - 46
900603-50008	10 - 16	C461-000010	11 - 34	P022-002100	4 - 43
900603-50008	12 - 16	C461-000010	11 - 34	P022-002860	12 - 47
900605-00005	1 - 22	C463-000000	9 - 34	P022-002890	12 - 42
900701-00012	2 - 2	C463-000000	9 - 34	P022-003310	12 - 42
900702-00022	10 - 22	C535-000000	10 - 6	P022-003310	12 - 42
900702-00022	12 - 22	C535-000000	12 - 4	P022-003330	12 - 47
900702-00032	10 - 7	C535-000001	10 - 6	P022-003330	12 - 47
900702-00032	12 - 7	C535-000001	12 - 4	P022-004600	4 - 25
900702-00032	2 - 4	C535-000010	10 - 14	P022-004610	4 - 22
900706-00010	10 - 23	C535-000010	12 - 6	P022-004620	4 - 23
900706-00010	12 - 23	C535-000011	10 - 14	P022-004630	4 - 31
900720-00012	10 - 5	C535-000011	12 - 6	P022-004640	4 - 30
900720-00012	12 - 3	C550-000080	8 - 11	P022-004650	4 - 29
900810-00626	10 - 13	C550-000080	8 - 11	P022-004660	4 - 27
900810-00626	12 - 13	C550-000090	8 - 21	P022-004670	4 - 28
900810-36201	1 - 14	C550-000090	8 - 21	P022-004680	4 - 24
900812-06201	10 - 9	C550-000100	8 - 15	P022-004690	4 - 26
900812-06201	12 - 9	C550-000100	8 - 15	P022-004740	4 - 41
900814-06201	2 - 3	C554-000000	8 - 12	P022-005230	4 - 29
900855-06900	10 - 20	C554-000000	8 - 12	P022-006190	12 - 45
900855-06900	12 - 20	P005-000390	13 - 22	V104-000160	5 - 22
900858-06900	10 - 21	P005-000590	13 - 15	V299-000110	9 - 24
900858-06900	12 - 21	P005-001050	13 - 11	V299-000110	9 - 24
94035-36201	1 - 14	P005-001710	13 - 25	V332-000000	12 - 41
A011-000101	1 - 9	P005-001810	14 -	V332-000000	12 - 41
A051-000290	4 - 19	P021-000050	5 - 21	V376-000360	4 - 35
A051-000291	4 - 19	P021-002610	9 - 1	V376-000361	4 - 35

Index

Patrs Number	Key No.	Patrs Number	Key No.	Patrs Number	Key No.
V430-000410	9 - 11				
V430-000410	9 - 11				
V452-000050	9 - 6				
V452-000050	9 - 6				
V452-000060	9 - 8				
V452-000060	9 - 8				
V452-000120	11 - 33				
V452-000120	11 - 33				
V452-000130	9 - 6				
V452-000130	9 - 6				
V471-001190	6 - 14				
V471-001200	6 - 9				
V553-000010	1 - 10				
V553-000030	1 - 10				
X047-000050	12 - 40				
X047-000150	12 - 40				
X047-000151	12 - 40				
X047-000260	12 - 40				
X405-000010	10 - 30				
X405-000011	10 - 30				
X470-000020	12 - 42				
X502-000031	4 - 18				
X502-000032	4 - 18				
X505-000140	11 - 1				
X505-000620	4 - 16				
X543-000110	1 - 24				
X602-000020	8 - 3				
X690-000030	8 - 5				

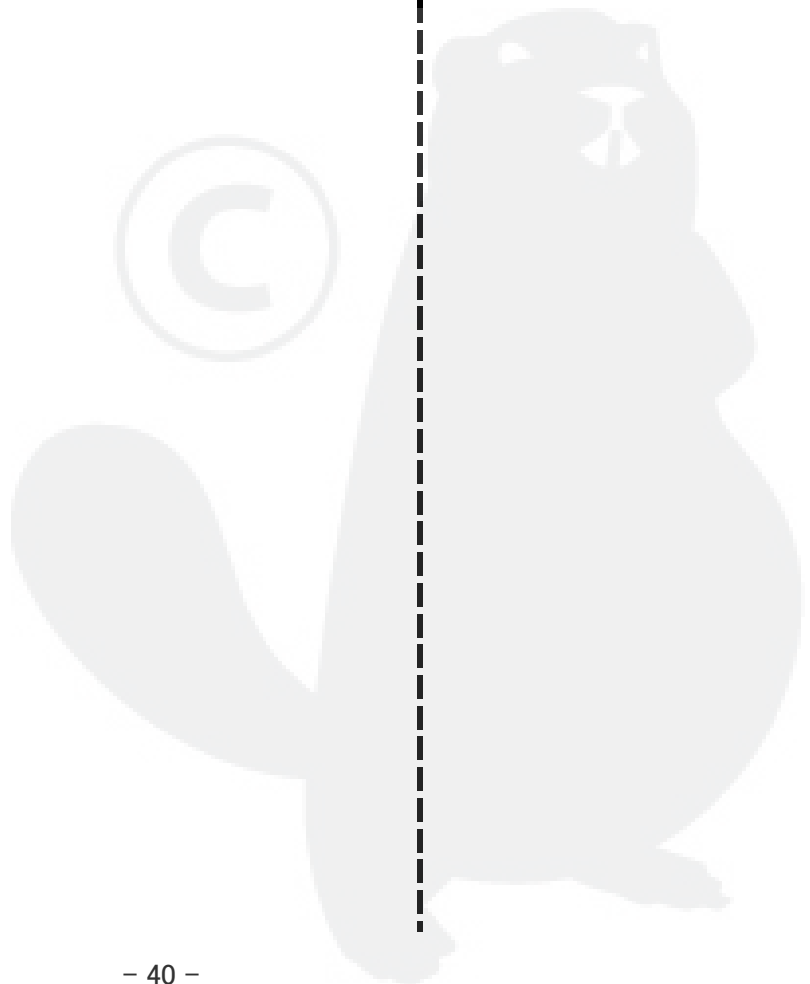
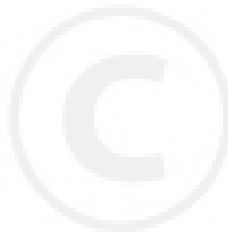

YAMABIKO CORPORATION

7-2 SUEHIROCHO 1-CHOME, OHME, TOKYO 198-8760, JAPAN
PHONE: 81-428-32-6118. FAX: 81-428-32-6145.

ECHO®

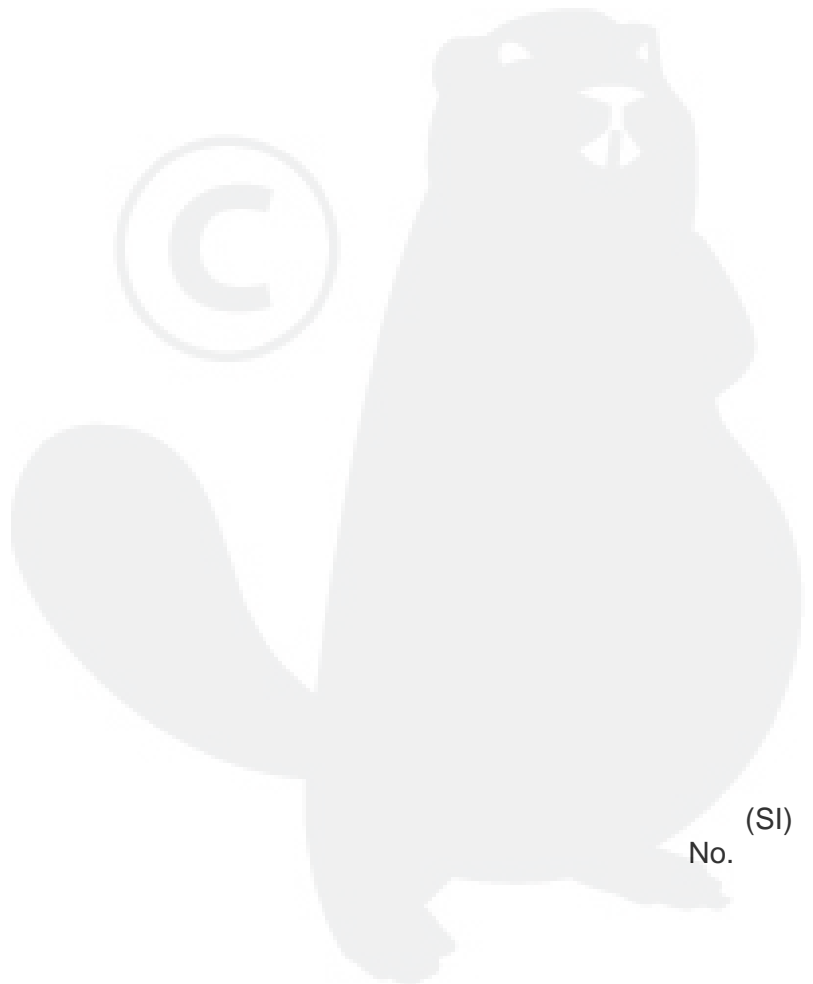
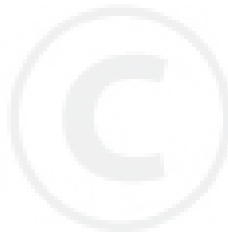

(SI)
No.