



PARTS CATALOG

DUSTER / MIST BLOWER

DM-4610 (36)

36002733 -

P014-000190-10Hb

1. CYLINDER, CRANKCASE, PISTON

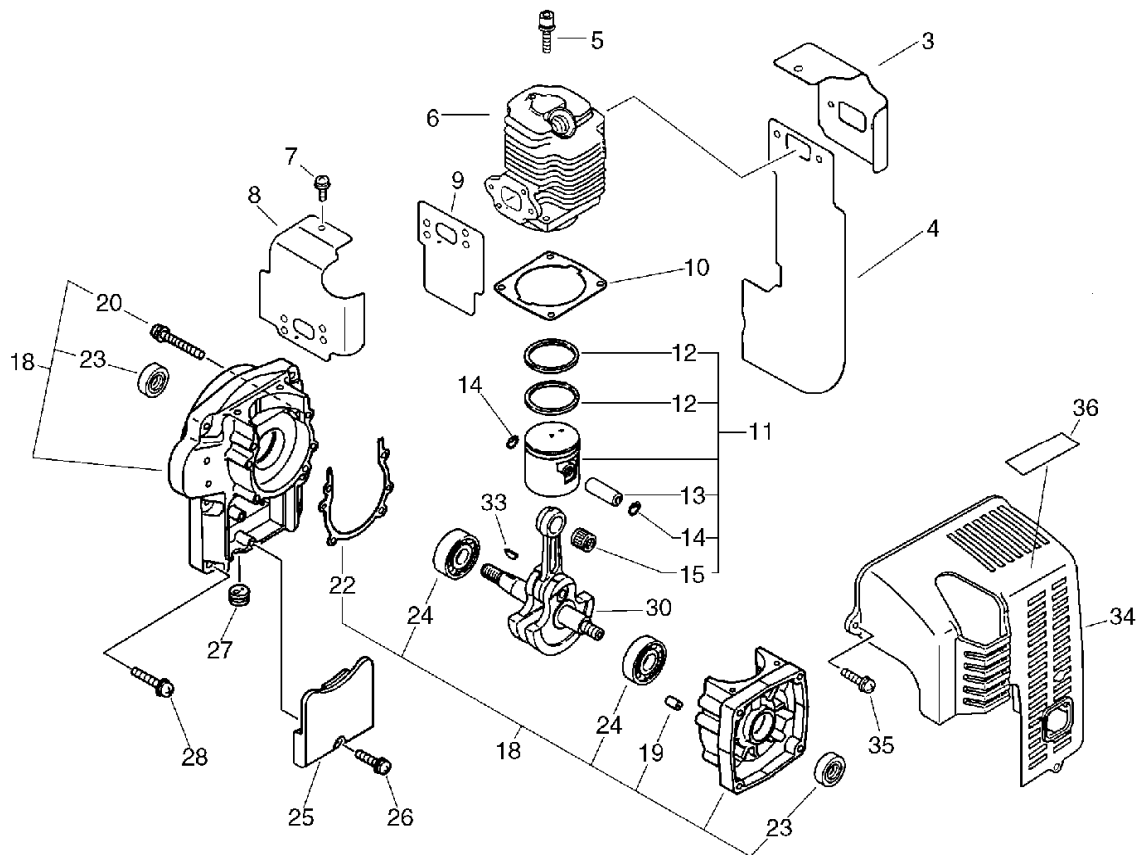

KEY	LV	PART NUMBER	Q'TY	DESCRIPTION	REMARKS	NOTE1	NOTE2
3		101514-06210	1	COVER, CYLINDER			
4		145512-06211	1	GASKET, MUFFLER			
5		900162-05022	4	BOLT, H.S. 5*22	5*22 W,SW		
6		A130-000210	1	CYLINDER			
7		900242-05010	1	SCREW 5*10			
8		A160-000680	1	COVER, CYLINDER			
9		130016-06211	1	GASKET, INTAKE			
10		101010-10722	1	GASKET, CYL. BASE			
11		P021-002540	1	PISTON KIT			
12	+	100011-10530	2	RING, PISTON			
13	+	100013-00410	1	PIN, PISTON	6*10*29.8		
14	+	100015-00120	2	CIRCLIP, PISTON PIN			
14	+	V580-000010	2	RING, END	φ0.8		
15	+	100012-12330	1	BEARING, NEEDLE			
18		100204-08261	1	CRANKCASE KIT			
19	+	100215-03930	2	PIN, DOWEL			
20	+	900242-05040	4	SCREW 5*40	5*40		
22	+	100242-10721	1	GASKET, CRANKCASE			
23	+	100213-00310	2	OILSEAL	ISCD 15 25 7		
24	+	900810-36202	2	BEARING, BALL 6202	6202/C3		
25		159129-08261	1	COVER, DUST			
26		900238-05018	1	SCREW 5*18	5*18		
27		150112-00310	1	BUSHING			
28		900292-05025	6	SCREW 5*25	5*25 SUS		
30		100100-06210	1	CRANKSHAFT ASSY			
33		900323-03014	1	KEY WOODRUFF	3*14		

1. CYLINDER, CRANKCASE, PISTON

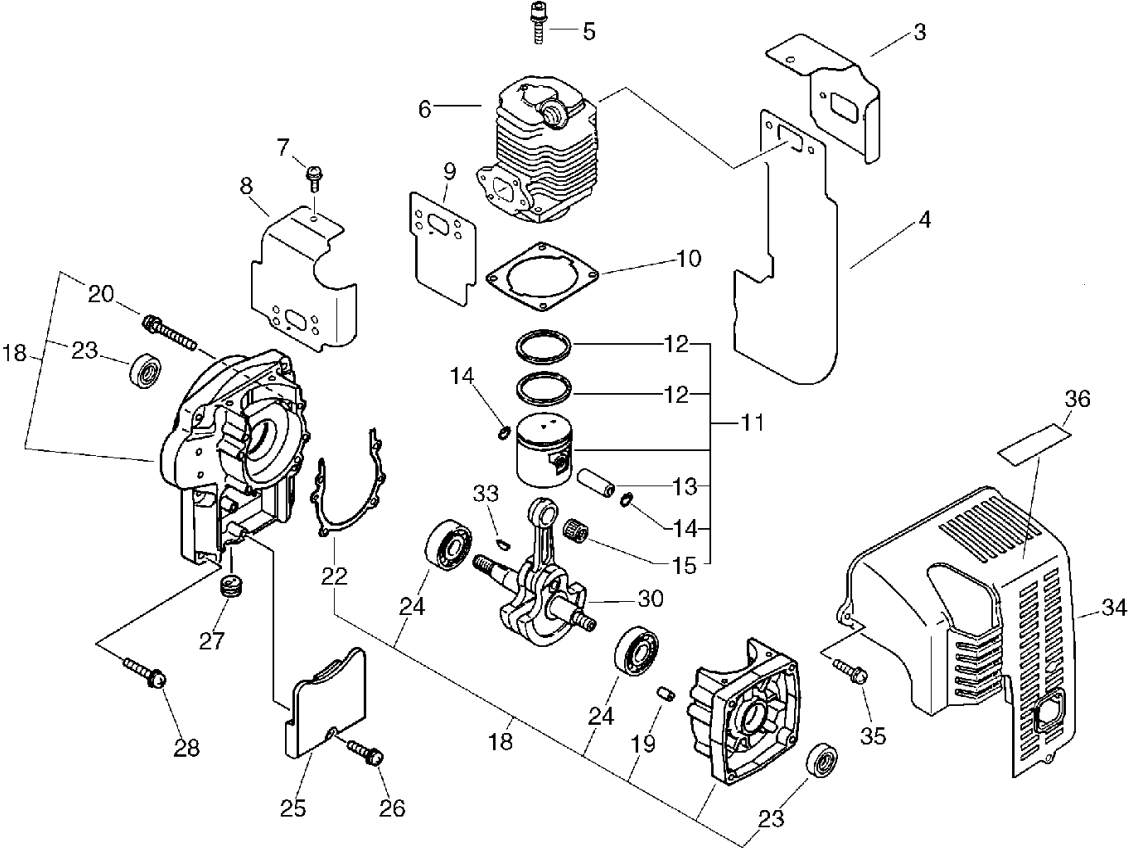

KEY	LV	PART NUMBER	Q'TY	DESCRIPTION	REMARKS	NOTE1	NOTE2
34		104016-06410	1	COVER, ENGINE			
35		900292-05020	3	SCREW 5*20	5*20 SUS		
36		X505-002310	1	LABEL, CAUTION	HOT CAUTION		

2. AIR CLEANER, FUEL TANK

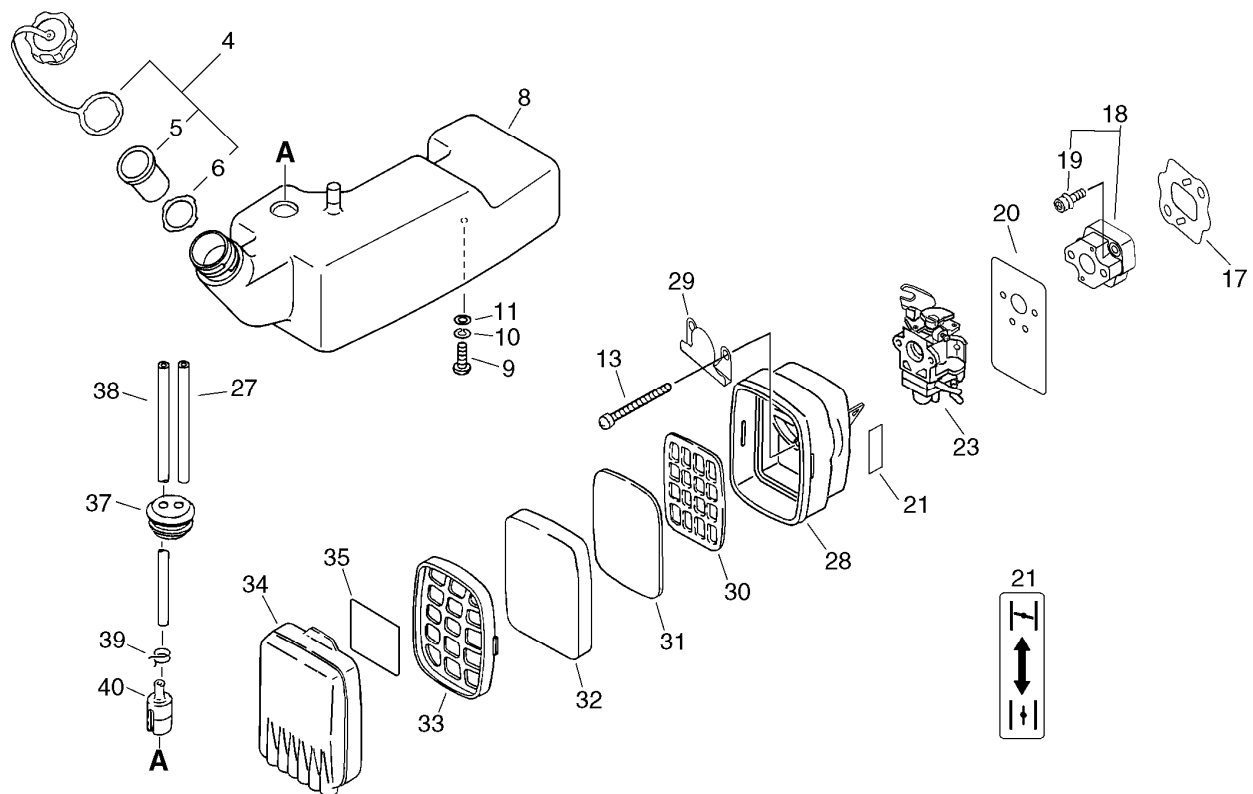

KEY	LV	PART NUMBER	Q'TY	DESCRIPTION	REMARKS	NOTE1	NOTE2
4		131600-21060	1	CAP ASSY, FUEL TANK			
5		131003-05330	1	CUP SET, VENT			
6	+	131016-21060	1	GASKET, FUEL CAP			
8		A350-000341	1	TANK,FUEL			
8		A350-000342	1	TANK,FUEL			
9		900220-06014	2	SCREW +-SR 6*14	6*14		
10		900605-00006	2	WASHER, SPRING 6	6		
11		145642-00760	2	WASHER 6.5*18*1.6	6.5*18*1.6		
13		91331-05060	2	SCREW	SR 5*60ZM		
17		V103-000000	1	GASKET,INTAKE			
18		P021-010210	1	INSULATOR,INTAKE KIT			
19	+	900106-05030	2	BOLT, H.S.H. 5*30	5*30		
20		V103-000221	1	GASKET,INTAKE	ASK NO.4750		
21		890121-65830	1	LABEL, CHOKE			
23		A021-001040	1	CARBURETOR,DIAPHRAGM	WYK-200		
27		V471-000550	1	PIPE	3*6*145		
28		P021-008620	1	CLEANER CASE ASY			
29		A244-000040	1	PLATE,PREVENT			
30		130319-03710	1	GRID, AIR CLEANER			
31		130317-03710	1	FILTER, AIR			
32		130310-02910	1	FILTER, AIR			
33		130311-03710	1	GRID, AIR CLEANER			
34		130313-03710	1	COVER, AIR CLEANER			
35		890187-03710	1	LABEL, CLEANER			
37		132115-56230	1	GROMMET, FUEL			
38		V471-000770	1	PIPE			

2. AIR CLEANER, FUEL TANK

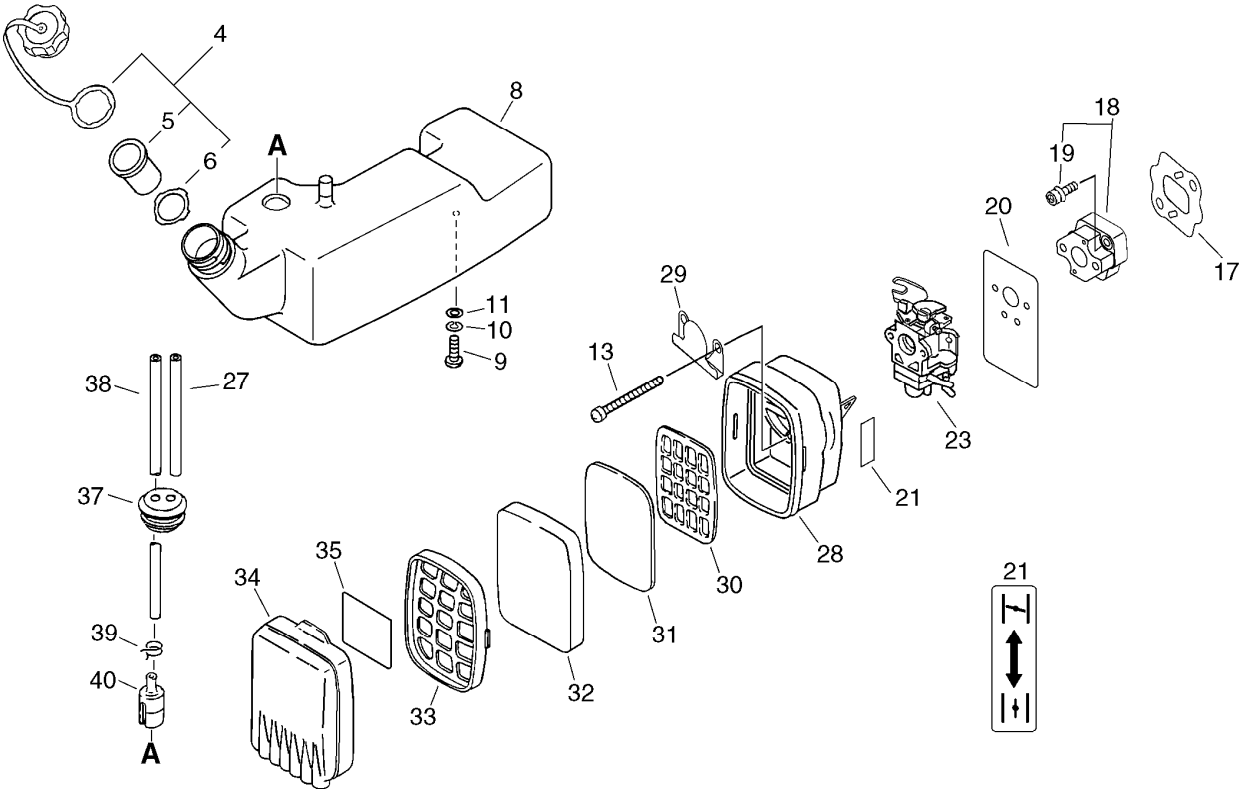

KEY	LV	PART NUMBER	Q'TY	DESCRIPTION	REMARKS	NOTE1	NOTE2
39		132013-26630	1	CLIP	6.5MM		
40		131205-19831	1	STRAINER, FUEL			

3. STARTER, MAGNETO, MUFFLER

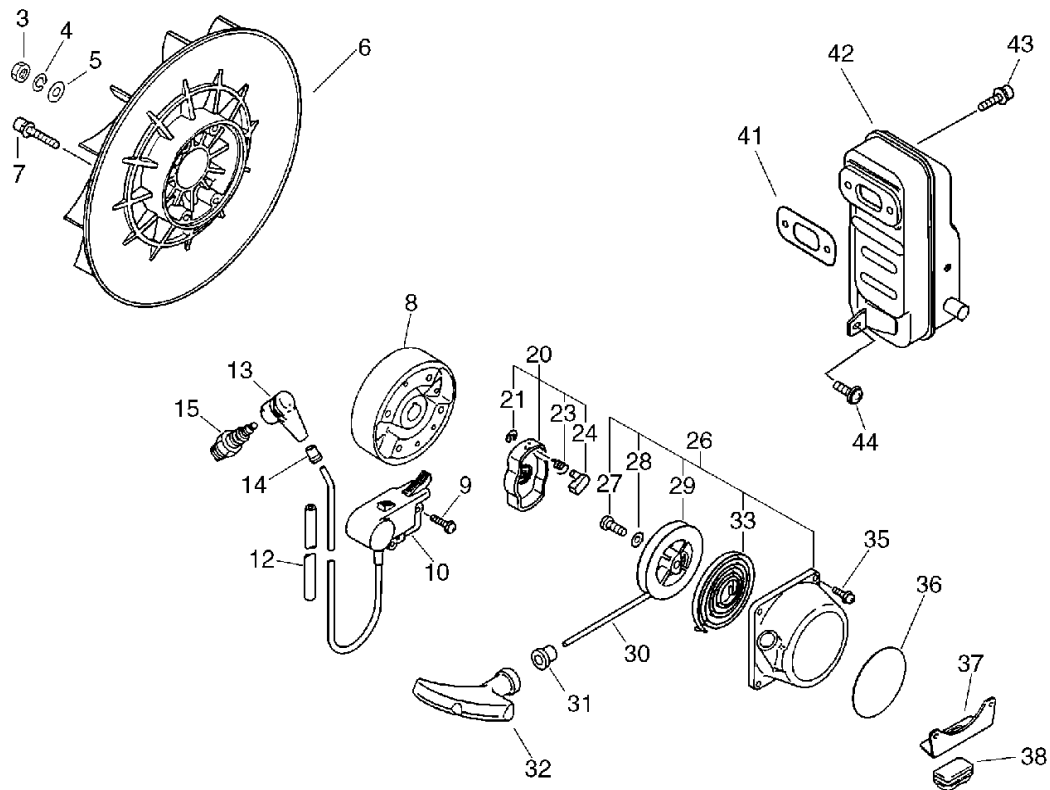

KEY	LV	PART NUMBER	Q'TY	DESCRIPTION	REMARKS	NOTE1	NOTE2
3		900501-00010	1	NUT 10*1.25	10*P1.25		
4		900605-00010	1	WASHER, SPRING 10	10		
5		900602-00010	1	WASHER 10(10.5*21*2)	10.5*21*2		
6		200005-06210	1	FAN			
7		900148-05035	4	BOLT 5*35	5*35		
8		156800-06161	1	ROTOR, MAGNETO			
9		900238-05018	2	SCREW 5*18	5*18		
10		156601-06211	1	C.D. IGNITION MODULE			
12		156611-04260	1	TUBE	6*8*340		
13		159012-10230	1	CAP, SPARK PLUG			
14		159016-05330	1	ADAPTER, PLUG CAP			
15		159010-10230	1	PLUG, SPARK (BPMR-7A)	BPMR-7A		
20		177202-06210	1	PAWL ASSY, STARTER			
21	+	900700-00004	1	E-RING 4	CE-4		
23	+	177234-40630	1	SPRING, RETURN			
24	+	177218-40630	1	PAWL, STARTER	WHITE		
26		177200-06210	1	STARTER ASSY			
27	+	177236-40630	1	SCREW			
28	+	177214-40630	1	WASHER			
29	+	177215-11120	1	DRUM, STARTER			
30	+	177226-11120	1	ROPE, STARTER	3.8*1400		
31	+	177227-42030	1	GUIDE, ROPE			
32	+	177228-11120	1	GRIP, STARTER			
33	+	177220-11120	1	REWIND SPRING			
35		900292-04018	4	SCREW 4*18	4*18 SUS		
36		X502-000410	1	LABEL,ECHO			

3. STARTER, MAGNETO, MUFFLER

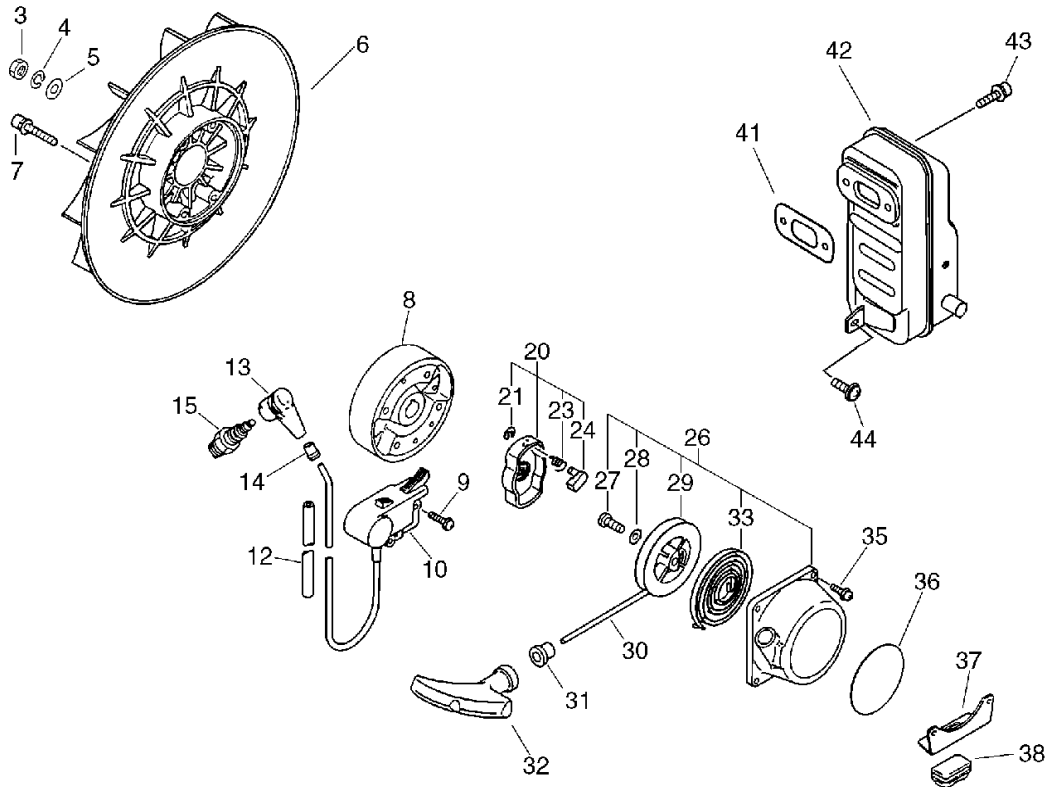

KEY	LV	PART NUMBER	Q'TY	DESCRIPTION	REMARKS	NOTE1	NOTE2
37		300029-06210	1	PLATE, ANGLE			
38		305117-03360	1	CUSHION			
41		145510-06211	1	GASKET, MUFFLER			
42		P021-008630	1	MUFFLER ASY			
43		900105-06020	2	BOLT, H.S. 6*20	6*20		
44		900242-05014	1	SCREW 5*14			

4. FAN CASE

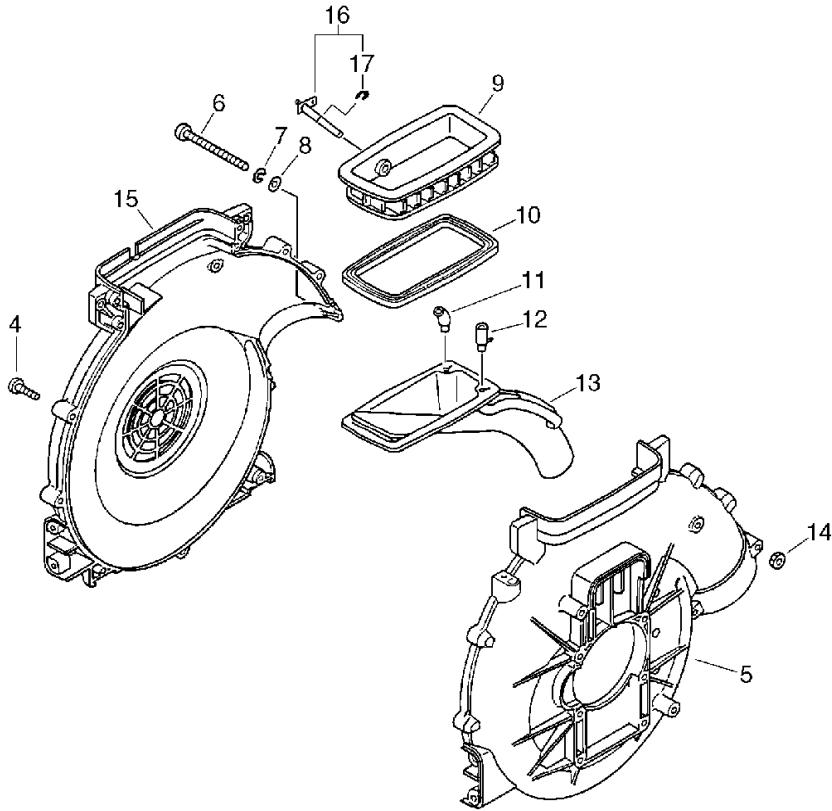

KEY	LV	PART NUMBER	Q'TY	DESCRIPTION	REMARKS	NOTE1	NOTE2
4		900286-05025	11	SCREW 5*25 SUS	5*25 SUS		
5		200107-07711	1	CASE, FAN			
5		200107-07712	1	CASE, FAN			
6		210425-04110	2	BOLT			
7		900609-00005	2	WASHER, SPRING 5 SUS	5 SUS		
8		900604-00005	2	WASHER 5 SUS	5 SUS		
9		270010-06211	1	TANK, LOWER			
10		270018-06210	1	PACKING			
11		370321-06210	1	PLATE			
12		370316-06210	1	GUIDE, AIR			
13		370301-06211	1	PIPE, DUST OUTLET			
14		900504-00005	2	NUT 5B	5B		
15		200105-07711	1	CASE, FAN			
15		200105-07712	1	CASE, FAN			
16		701033-06211	1	PIN, STRAIGHT 10			
17	+	900703-00008	1	E-RING 8 SUS	CE-8 SUS		

5. BACKPACK HARNESS

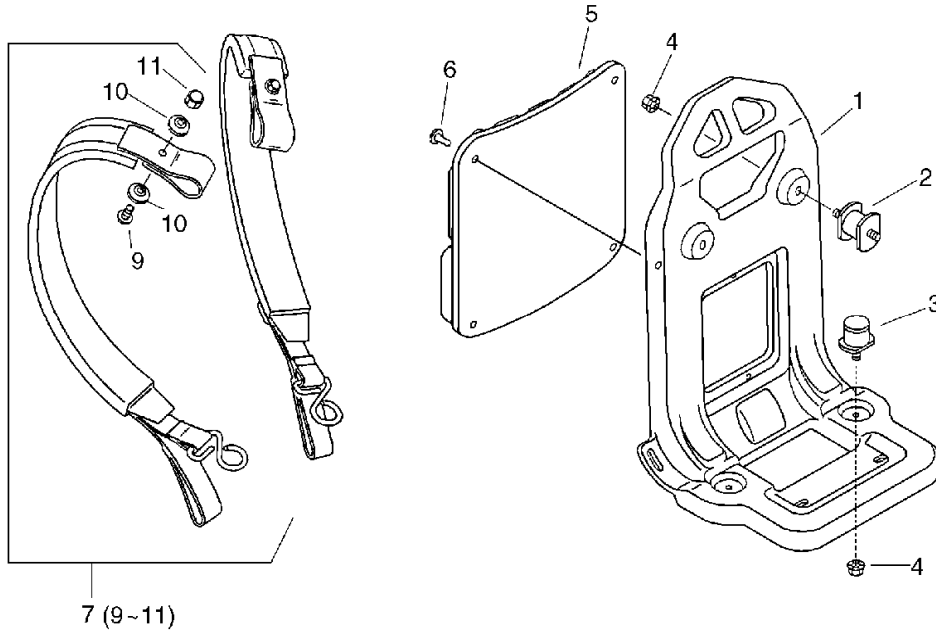

KEY	LV	PART NUMBER	Q'TY	DESCRIPTION	REMARKS	NOTE1	NOTE2
1		300010-07311	1	FRAME, BACKPACK			
2		200910-06210	2	CUSHION			
3		200916-03210	2	CUSHION			
4		250916-06210	4	NUT			
5		300111-14010	1	CUSHION, KNAPSACK			
6		300333-06160	4	CLIP			
7		300302-07410	1	HARNESS, W/PAD			
9	+	900216-05016	2	SCREW, 5*16	5*16		
10	+	300328-03210	4	WASHER, HARNESS			
11	+	900560-00005	2	NUT, LOCK 5	5		

6. THROTTLE

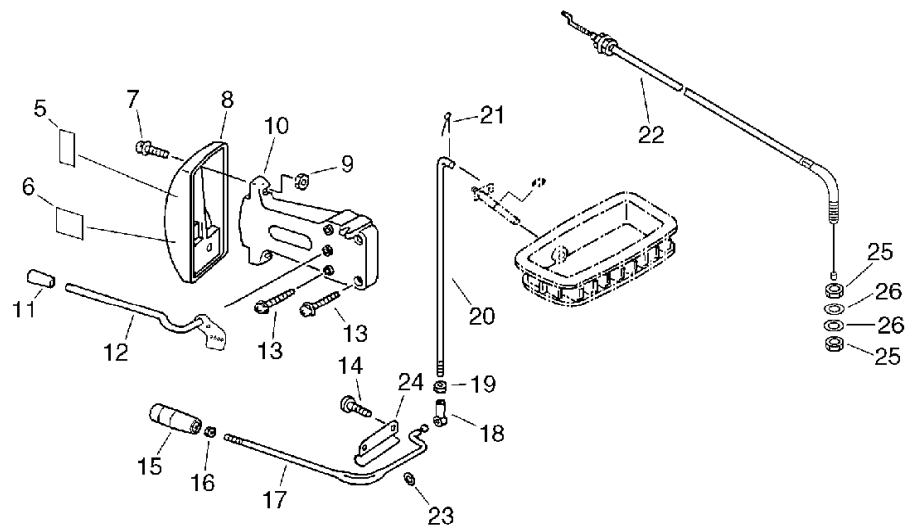

KEY	LV	PART NUMBER	Q'TY	DESCRIPTION	REMARKS	NOTE1	NOTE2
5		890348-05060	1	LABEL, SPEED			
6		890157-39130	1	LABEL, SWITCH			
7		900292-05025	2	SCREW 5*25	5*25 SUS		
8		701111-06212	1	DIAL			
8		701111-06213	1	DIAL			
9		900504-00005	2	NUT 5B	5B		
10		701112-06411	1	BRACKET, DIAL			
10		701112-06412	1	BRACKET, DIAL			
11		701021-02910	1	KNOB, LEVER			
12		C453-000130	1	LEVER, THROTTLE			
13		900286-05025	4	SCREW 5*25 SUS	5*25 SUS		
14		900292-05014	2	SCREW 5*14	5*14 SUS		
15		701007-06610	1	KNOB, LEVER			
16		900502-00006	1	NUT 6 (3N)	3N6		
17		701010-06610	1	LEVER, CONTROL			
18		701020-05510	1	CONNECTOR			
19		900500-00005	1	NUT 5	5		
20		701014-06510	1	ROD, CONTROL LEVER			
21		605612-06510	1	PIN, SNAP			
22		V430-001330	1	CABLE, BOWDEN			
23		900600-00008	1	WASHER 8	8		
24		701028-06210	1	HOLDER, STOPPER			
25		900503-00006	2	NUT (3N 6*0.75)	3N 6*0.75		
26		900600-00006	2	WASHER 6	6		

7. CHEMICAL TANK

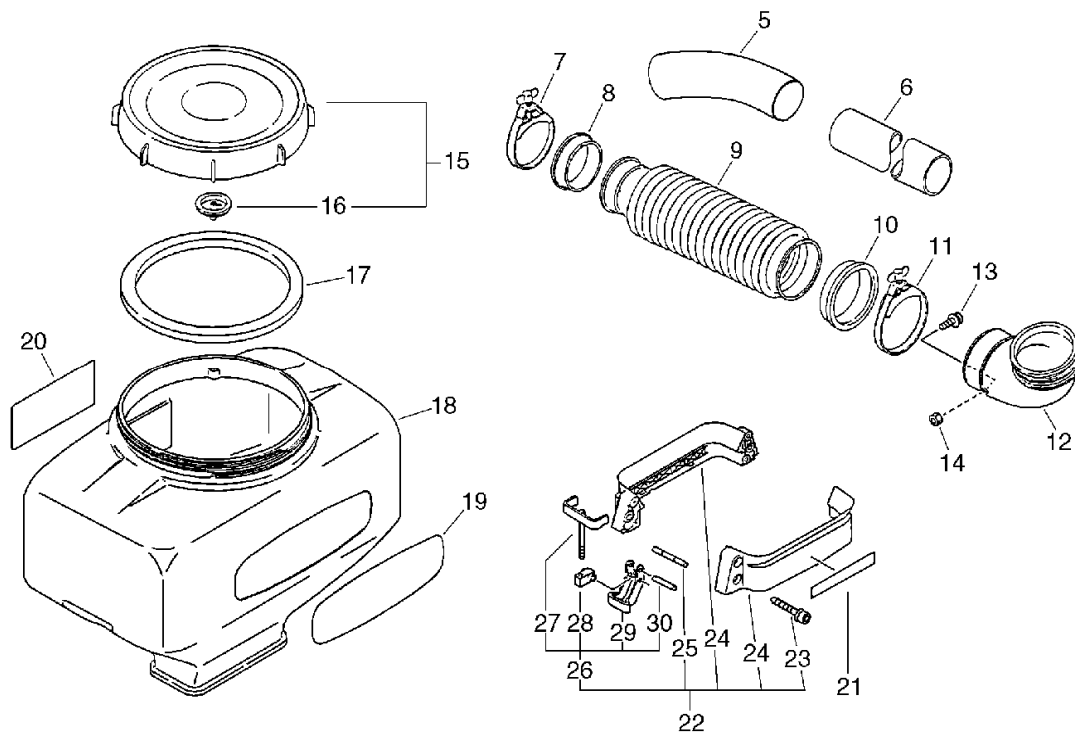

KEY	LV	PART NUMBER	Q'TY	DESCRIPTION	REMARKS	NOTE1	NOTE2
5		210023-00210	1	PIPE, CURVED (GY)			
6		210014-01610	1	PIPE, STRAIGHT			
7		210407-01110	1	CLAMP, FLEXIBLE PIPE			
7		V495-001170	1	BAND			
8		210032-04110	1	PACKING, FLX. PIPE			
9		210013-04111	1	PIPE, FLEXIBLE			
10		210036-04110	1	GASKET, FLX. PIPE			
11		210407-04110	1	CLAMP, FLEXIBLE PIPE			
11		V495-001200	1	BAND			
12		210011-05510	1	ELBOW, BLOWING			
13		900500-00005	1	NUT 5	5		
14		900242-05014	1	SCREW 5*14			
15		250001-05610	1	CAP, CHEMICAL TANK			
16	+	250013-00310	1	CAP, INSIDE			
17		250011-02011	1	PACKING			
18		250017-08012	1	TANK, CHEMICAL	23L EU (MIST)		
19		X502-000440	1	LABEL,ECHO			
20		890160-09461	1	LABEL, CAUTION			
21		X503-008350	1	LABEL,MODEL	DM-4610		
23	+	91148-05035	4	BOLT HS FL TAPP	M5*35		
24	+	250910-06310	2	HOLDER, C. TANK			
25	+	250914-06210	2	PIN, TANK HOLDER			
26		250902-06310	1	BRACKET ASSY, C.TANK			
27	++	250915-06310	2	BOLT, TANK HOLDER			
28	++	250930-06210	2	CONNECTOR, BRACKET			

7. CHEMICAL TANK

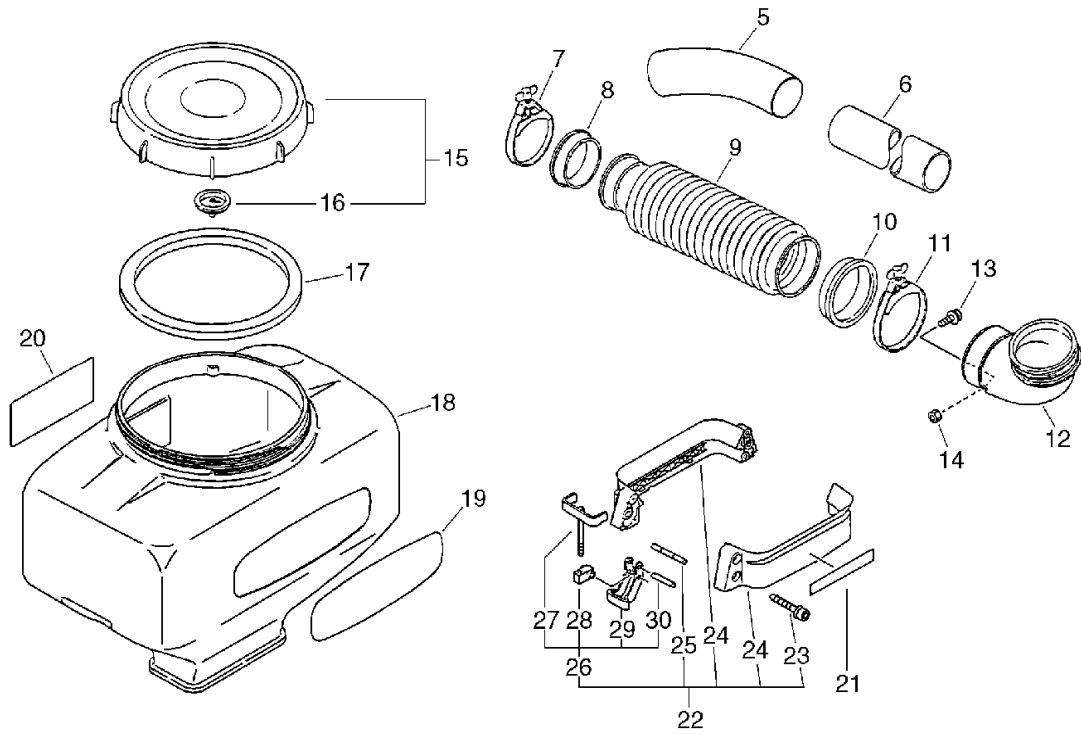

KEY	LV	PART NUMBER	Q'TY	DESCRIPTION	REMARKS	NOTE1	NOTE2
29	++	250932-06210	2	BRACKET, TANK			
30	++	900333-70380	2	PIN, STRAIGHT			

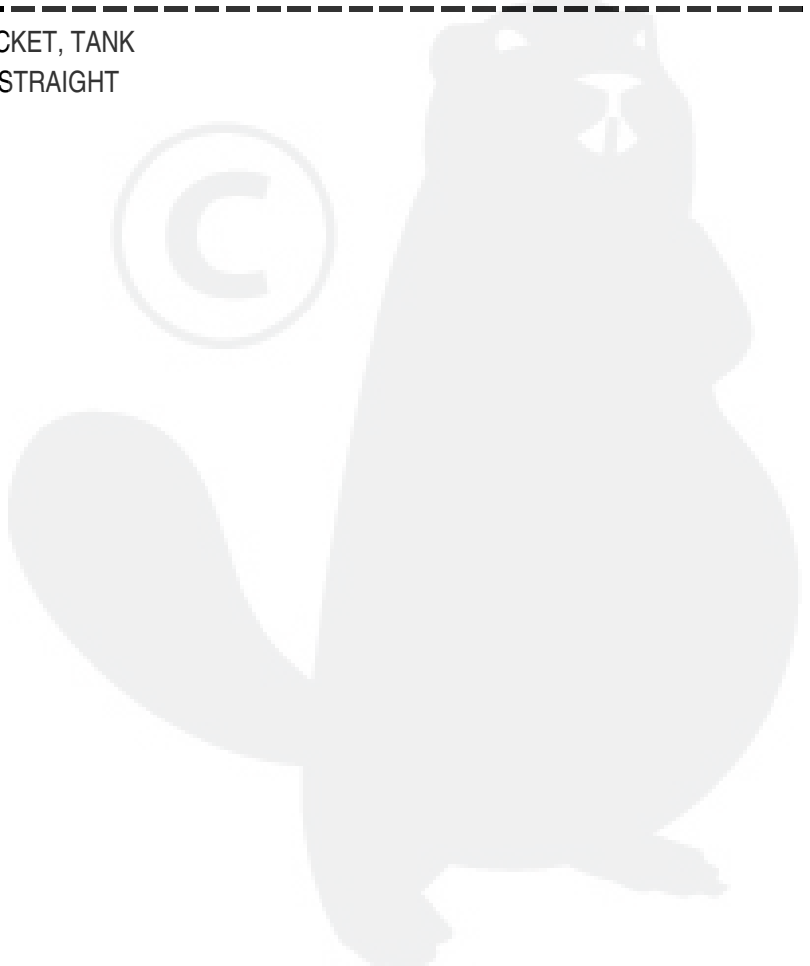
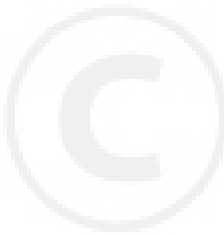

8. MIST BLOWER

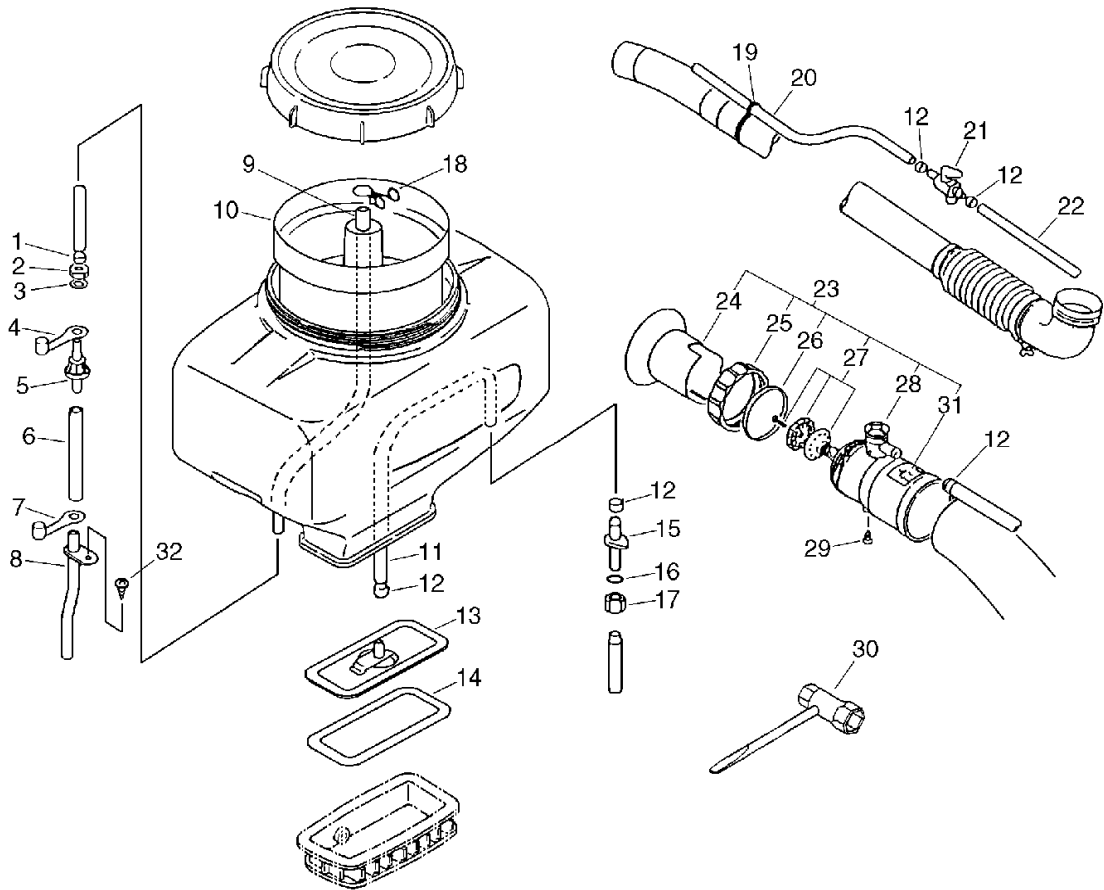

KEY	LV	PART NUMBER	Q'TY	DESCRIPTION	REMARKS	NOTE1	NOTE2
1		132013-14010	1	BAND	10.5MM		
2		363019-00310	1	NUT, CONNECTOR			
3		363018-00310	1	WASHER			
4		363022-00510	1	PLUG			
5		363017-00310	1	CONNECTOR, PIPE			
6		363011-00210	1	PIPE, AIR (OUTER)			
7		363021-01110	1	PLUG			
8		E105-000000	1	PIPE,AIR			
9		363014-03210	1	PIPE (INNER)	7*11*500BL		
10		254210-03210	1	FILTER			
11		382011-01110	1	PIPE (9*13)	9*13*350		
12		V495-000310	5	BAND			
13		253010-08010	1	PLATE, TANK BOTTOM			
14		270119-06210	1	GASKET, SHUTTER			
15		357010-01110	1	NIPPLE, OUTLET			
16		357014-01110	1	O-RING	3*13		
17		357015-01110	1	NUT, HOLLOW			
18		363023-01110	1	CLIP			
19		357911-00111	1	CLIP, PIPE			
20		357011-02410	1	PIPE (L-650)	9*13*650L		
21		358100-01111	1	COCK,LIQUID			
21		358100-01111	1	COCK,LIQUID			
22		357032-01110	1	PIPE (L-720)	9*13*720		
23		212500-01111	1	NOZZLE ASS'Y, MISTBL			
24	+	212515-01110	1	COLLAR, NOZZLE			
25	+	212514-01110	1	NUT, MISTING NOZZLE			

8. MIST BLOWER

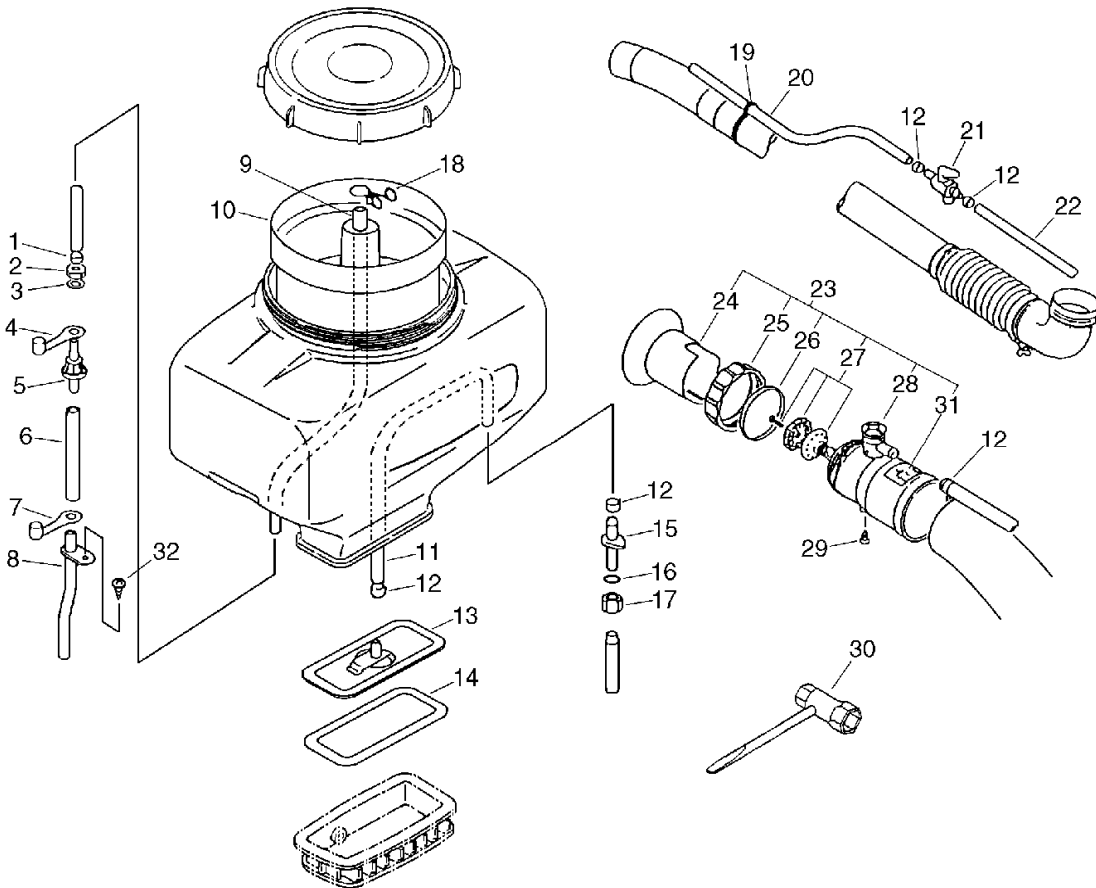

KEY	LV	PART NUMBER	Q'TY	DESCRIPTION	REMARKS	NOTE1	NOTE2
26	+	212513-01110	1	RING, MISTING NOZZLE			
27	+	222000-01110	1	NOZZLE			
28	+	212501-01111	1	HEAD, NOZZLE BL	BL		
29	++	900246-05012	1	SCREW 5*12	5*12		
31	+	890031-01110	1	LABEL, MIST			
30		X602-000020	1	TOOL, WRENCH	17*19 L200		
32		900286-05016	1	SCREW 5*16 SUS	5*16 SUS		

9. CARBURETOR

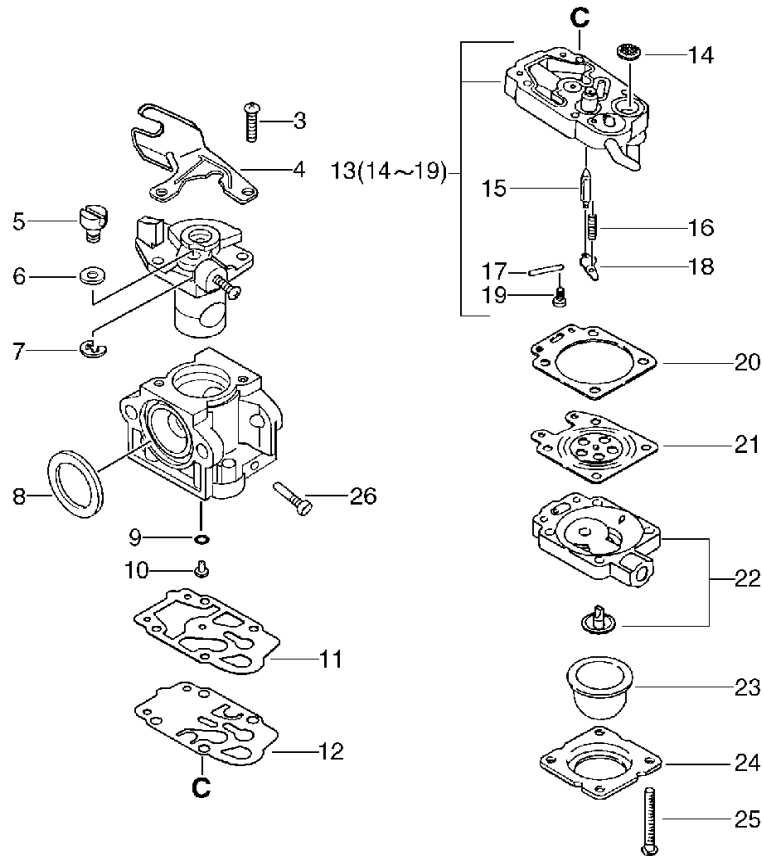

KEY	LV	PART NUMBER	Q'TY	DESCRIPTION	REMARKS	NOTE1	NOTE2
		A021-000980	1	CARBURETOR,DIAPHRAGM	WYK-JX-3746		
		A021-001040	1	CARBURETOR,DIAPHRAGM	WYK-200		
		A021-000990	1	CARBURETOR,DIAPHRAGM	WYK-201		
3	+	123114-40630	2	SCREW			
4	+	P003-000180	1	BRACKET CABLE			
5	+	123172-45130	1	SWIVEL			
6	+	123149-54230	1	WASHER			
7	+	123173-07930	1	CLIP			
8	+	123143-12110	1	RING, PACKING			
9	+	123183-40630	1	O-RING			
10	+	P003-000990	1	JET			
11	+	123125-40630	1	GASKET, PUMP			
12	+	123112-40630	1	DIAPHRAGM, PUMP			
13	+	123179-05560	1	BODY ASSY, PUMP			
14	++	123126-10631	1	SCREEN, INLET			
15	++	123137-19830	1	VALVE, INLET NEEDLE			
16	++	123122-05560	1	SPRING, METER. LEVER			
17	++	123138-03930	1	PIN, METERING LEVER			
18	++	123123-03930	1	LEVER, METERING			
19	++	123139-05560	1	SCREW, M. LEVER PIN			
20	+	123140-05560	1	GASKET, M. DIAPHRAGM			
21	+	P003-000090	1	METERING, DIAPHRAGM			
22	+	123180-05560	1	BODY, AIR PURGE			
23	+	123181-40630	1	PUMP, PRIMER			
24	+	123142-05560	1	COVER, PRIMER PUMP			
25	+	123110-05560	4	SCREW, PUMP COVER			

9. CARBURETOR

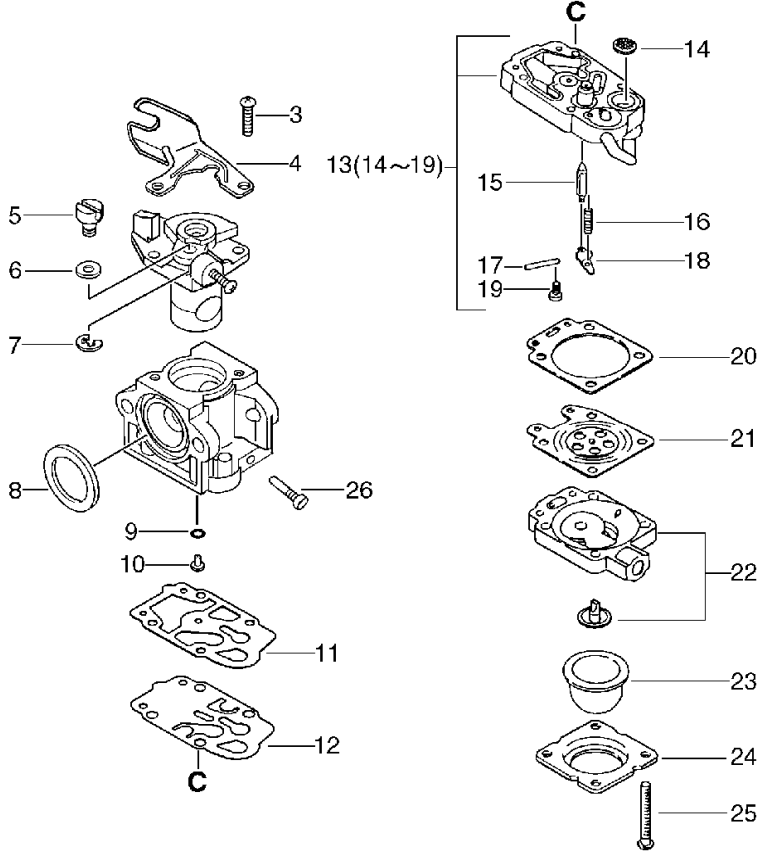

KEY	LV	PART NUMBER	Q'TY	DESCRIPTION	REMARKS	NOTE1	NOTE2
26	+	P003-001130	1	NEEDLE, HIGH SPEED			



10. DUST ATTACHMENT

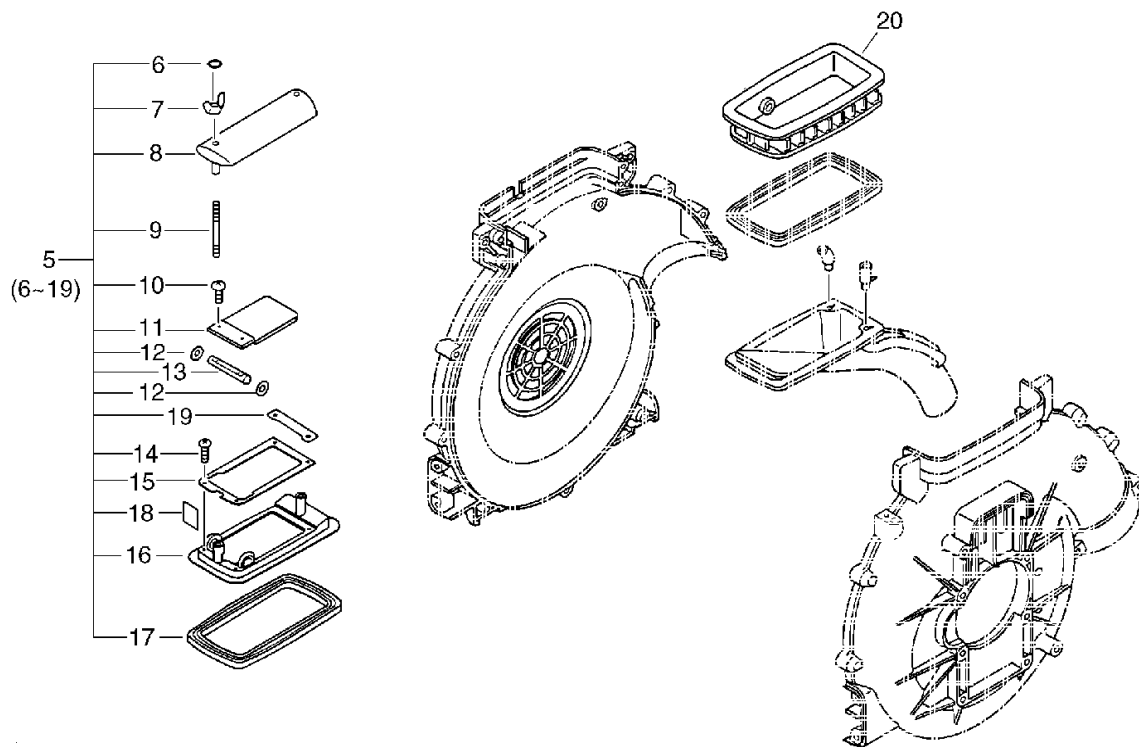

KEY	LV	PART NUMBER	Q'TY	DESCRIPTION	REMARKS	NOTE1	NOTE2
5		275100-06212	1	SHUTTER ASSY			
6	+	900720-00004	1	O-RING (P-4)	P-4		
7	+	900539-00005	1	NUT, WING 5	5		
8	+	250110-06212	1	STABILIZER			
9	+	270015-06211	1	BOLT, STUD	5*50		
10	+	900226-04010	2	SCREW, 4*10	4*10 SUS		
11	+	270145-06210	1	SHUTTER			
12	+	275123-05510	2	SPACER 10*19.5*0.3	10*19.5*0.3		
13	+	270153-06210	1	SHAFT, SHUTTER			
14	+	900295-04014	4	SCREW 4*14	4*14 SUS		
15	+	270110-06210	1	SHUTTER			
16	+	270112-06211	1	SHUTTER, METERING			
17	+	270119-06210	1	GASKET, SHUTTER			
18	+	210035-06310	1	PACKING, DUST			
19	+	270122-06211	1	PLATE, EYE			
20		270010-06211	1	TANK, LOWER			

11. DUST ATTACHMENT

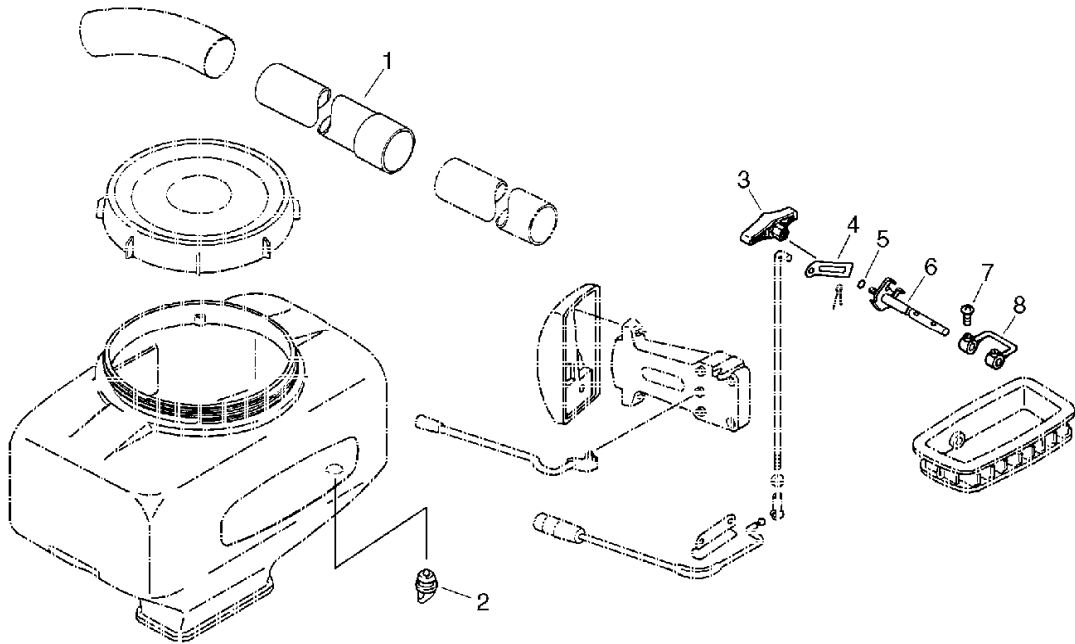

KEY	LV	PART NUMBER	Q'TY	DESCRIPTION	REMARKS	NOTE1	NOTE2
1		210015-01110	1	PIPE, STRAIGHT (GY)			
2		250016-01110	1	PLUG			
3		270207-04310	1	NUT (BS)			
4		270212-06410	1	ARM, SHUTTER			
5		900720-00007	1	O-RING 7	P-7		
6		270205-06411	1	SHAFT, SHUTTER			
7		900292-04014	2	SCREW 4*14	4*14 SUS		
8		270216-06210	1	ARM			

Index

Patrs Number	Key No.	Patrs Number	Key No.	Patrs Number	Key No.
100011-10530	1 - 12	156601-06211	3 - 10	250910-06310	7 - 24
100012-12330	1 - 15	156611-04260	3 - 12	250914-06210	7 - 25
100013-00410	1 - 13	156800-06161	3 - 8	250915-06310	7 - 27
100015-00120	1 - 14	159010-10230	3 - 15	250916-06210	5 - 4
100100-06210	1 - 30	159012-10230	3 - 13	250930-06210	7 - 28
100204-08261	1 - 18	159016-05330	3 - 14	250932-06210	7 - 29
100213-00310	1 - 23	159129-08261	1 - 25	253010-08010	8 - 13
100215-03930	1 - 19	177200-06210	3 - 26	254210-03210	8 - 10
100242-10721	1 - 22	177202-06210	3 - 20	270010-06211	4 - 9
101010-10722	1 - 10	177214-40630	3 - 28	270010-06211	10 - 20
101514-06210	1 - 3	177215-11120	3 - 29	270015-06211	10 - 9
104016-06410	1 - 34	177218-40630	3 - 24	270018-06210	4 - 10
123110-05560	9 - 25	177220-11120	3 - 33	270110-06210	10 - 15
123112-40630	9 - 12	177226-11120	3 - 30	270112-06211	10 - 16
123114-40630	9 - 3	177227-42030	3 - 31	270119-06210	8 - 14
123122-05560	9 - 16	177228-11120	3 - 32	270119-06210	10 - 17
123123-03930	9 - 18	177234-40630	3 - 23	270122-06211	10 - 19
123125-40630	9 - 11	177236-40630	3 - 27	270145-06210	10 - 11
123126-10631	9 - 14	200005-06210	3 - 6	270153-06210	10 - 13
123137-19830	9 - 15	200105-07711	4 - 15	270205-06411	11 - 6
123138-03930	9 - 17	200105-07712	4 - 15	270207-04310	11 - 3
123139-05560	9 - 19	200107-07711	4 - 5	270212-06410	11 - 4
123140-05560	9 - 20	200107-07712	4 - 5	270216-06210	11 - 8
123142-05560	9 - 24	200910-06210	5 - 2	275100-06212	10 - 5
123143-12110	9 - 8	200916-03210	5 - 3	275123-05510	10 - 12
123149-54230	9 - 6	210011-05510	7 - 12	300010-07311	5 - 1
123172-45130	9 - 5	210013-04111	7 - 9	300029-06210	3 - 37
123173-07930	9 - 7	210014-01610	7 - 6	300111-14010	5 - 5
123179-05560	9 - 13	210015-01110	11 - 1	300302-07410	5 - 7
123180-05560	9 - 22	210023-00210	7 - 5	300328-03210	5 - 10
123181-40630	9 - 23	210032-04110	7 - 8	300333-06160	5 - 6
123183-40630	9 - 9	210035-06310	10 - 18	305117-03360	3 - 38
130016-06211	1 - 9	210036-04110	7 - 10	357010-01110	8 - 15
130310-02910	2 - 32	210407-01110	7 - 7	357011-02410	8 - 20
130311-03710	2 - 33	210407-04110	7 - 11	357014-01110	8 - 16
130313-03710	2 - 34	210425-04110	4 - 6	357015-01110	8 - 17
130317-03710	2 - 31	212500-01111	8 - 23	357032-01110	8 - 22
130319-03710	2 - 30	212501-01111	8 - 28	357911-00111	8 - 19
131003-05330	2 - 5	212513-01110	8 - 26	358100-01111	8 - 21
131016-21060	2 - 6	212514-01110	8 - 25	358100-01111	8 - 21
131205-19831	2 - 40	212515-01110	8 - 24	363011-00210	8 - 6
131600-21060	2 - 4	222000-01110	8 - 27	363014-03210	8 - 9
132013-14010	8 - 1	250001-05610	7 - 15	363017-00310	8 - 5
132013-26630	2 - 39	250011-02011	7 - 17	363018-00310	8 - 3
132115-56230	2 - 37	250013-00310	7 - 16	363019-00310	8 - 2
145510-06211	3 - 41	250016-01110	11 - 2	363021-01110	8 - 7
145512-06211	1 - 4	250017-08012	7 - 18	363022-00510	8 - 4
145642-00760	2 - 11	250110-06212	10 - 8	363023-01110	8 - 18
150112-00310	1 - 27	250902-06310	7 - 26	370301-06211	4 - 13

Index

Patrs Number	Key No.	Patrs Number	Key No.	Patrs Number	Key No.
370316-06210	4 - 12	900501-00010	3 - 3	X502-000410	3 - 36
370321-06210	4 - 11	900502-00006	6 - 16	X502-000440	7 - 19
382011-01110	8 - 11	900503-00006	6 - 25	X503-008350	7 - 21
605612-06510	6 - 21	900504-00005	4 - 14	X505-002310	1 - 36
701007-06610	6 - 15	900504-00005	6 - 9	X602-000020	8 - 30
701010-06610	6 - 17	900539-00005	10 - 7		
701014-06510	6 - 20	900560-00005	5 - 11		
701020-05510	6 - 18	900600-00006	6 - 26		
701021-02910	6 - 11	900600-00008	6 - 23		
701028-06210	6 - 24	900602-00010	3 - 5		
701033-06211	4 - 16	900604-00005	4 - 8		
701111-06212	6 - 8	900605-00006	2 - 10		
701111-06213	6 - 8	900605-00010	3 - 4		
701112-06411	6 - 10	900609-00005	4 - 7		
701112-06412	6 - 10	900700-00004	3 - 21		
890031-01110	8 - 31	900703-00008	4 - 17		
890121-65830	2 - 21	900720-00004	10 - 6		
890157-39130	6 - 6	900720-00007	11 - 5		
890160-09461	7 - 20	900810-36202	1 - 24		
890187-03710	2 - 35	91148-05035	7 - 23		
890348-05060	6 - 5	91331-05060	2 - 13		
900105-06020	3 - 43	A021-000980	9 -		
900106-05030	2 - 19	A021-000990	9 -		
900148-05035	3 - 7	A021-001040	2 - 23		
900162-05022	1 - 5	A021-001040	9 -		
900216-05016	5 - 9	A130-000210	1 - 6		
900220-06014	2 - 9	A160-000680	1 - 8		
900226-04010	10 - 10	A244-000040	2 - 29		
900238-05018	1 - 26	A350-000341	2 - 8		
900238-05018	3 - 9	A350-000342	2 - 8		
900242-05010	1 - 7	C453-000130	6 - 12		
900242-05014	3 - 44	E105-000000	8 - 8		
900242-05014	7 - 14	P003-000090	9 - 21		
900242-05040	1 - 20	P003-000180	9 - 4		
900246-05012	8 - 29	P003-000990	9 - 10		
900286-05016	8 - 32	P003-001130	9 - 26		
900286-05025	4 - 4	P021-002540	1 - 11		
900286-05025	6 - 13	P021-008620	2 - 28		
900292-04014	11 - 7	P021-008630	3 - 42		
900292-04018	3 - 35	P021-010210	2 - 18		
900292-05014	6 - 14	V103-000000	2 - 17		
900292-05020	1 - 35	V103-000221	2 - 20		
900292-05025	1 - 28	V430-001330	6 - 22		
900292-05025	6 - 7	V471-000550	2 - 27		
900295-04014	10 - 14	V471-000770	2 - 38		
900323-03014	1 - 33	V495-000310	8 - 12		
900333-70380	7 - 30	V495-001170	7 - 7		
900500-00005	6 - 19	V495-001200	7 - 11		
900500-00005	7 - 13	V580-000010	1 - 14		

YAMABIKO CORPORATION

7-2 SUEHIROCHO 1-CHOME, OHME, TOKYO 198-8760, JAPAN
PHONE: 81-428-32-6118. FAX: 81-428-32-6145.

ECHO®

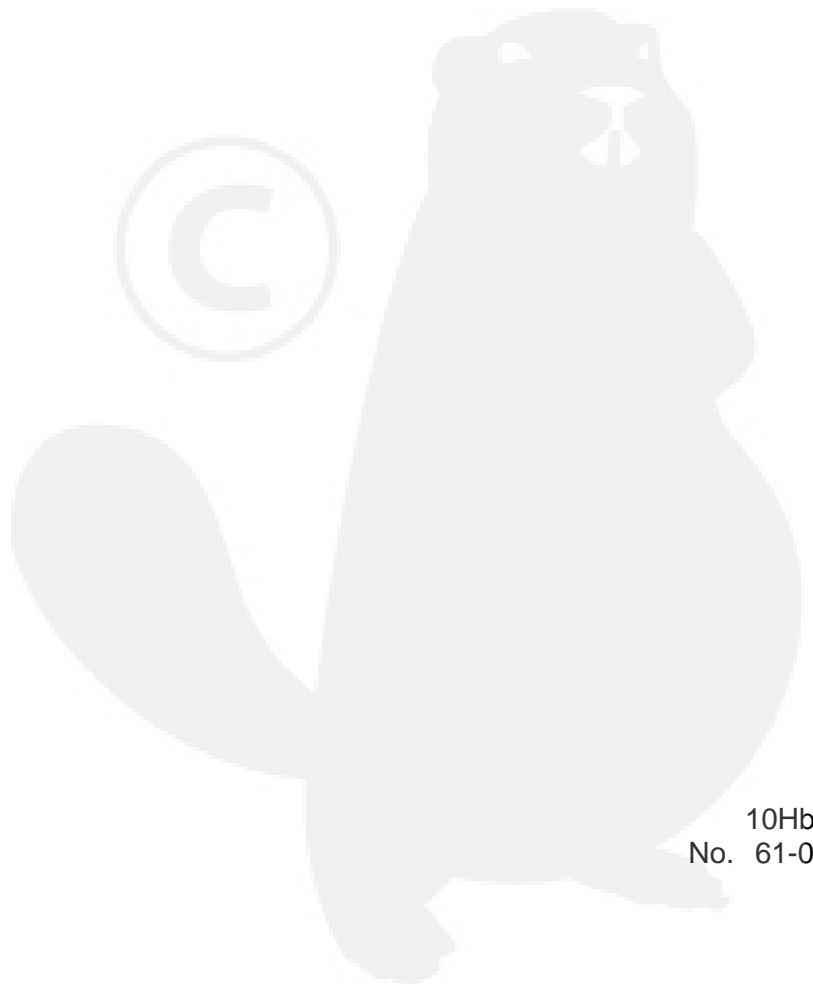
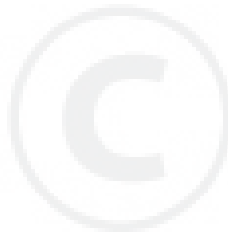

10Hb
No. 61-093