

DLM-310/46P

Serial Number

U61035000001-U61035999999

Last updated date

01/Oct/2021

TABLE OF CONTENTS

BODY	1
COVER	3

BODY

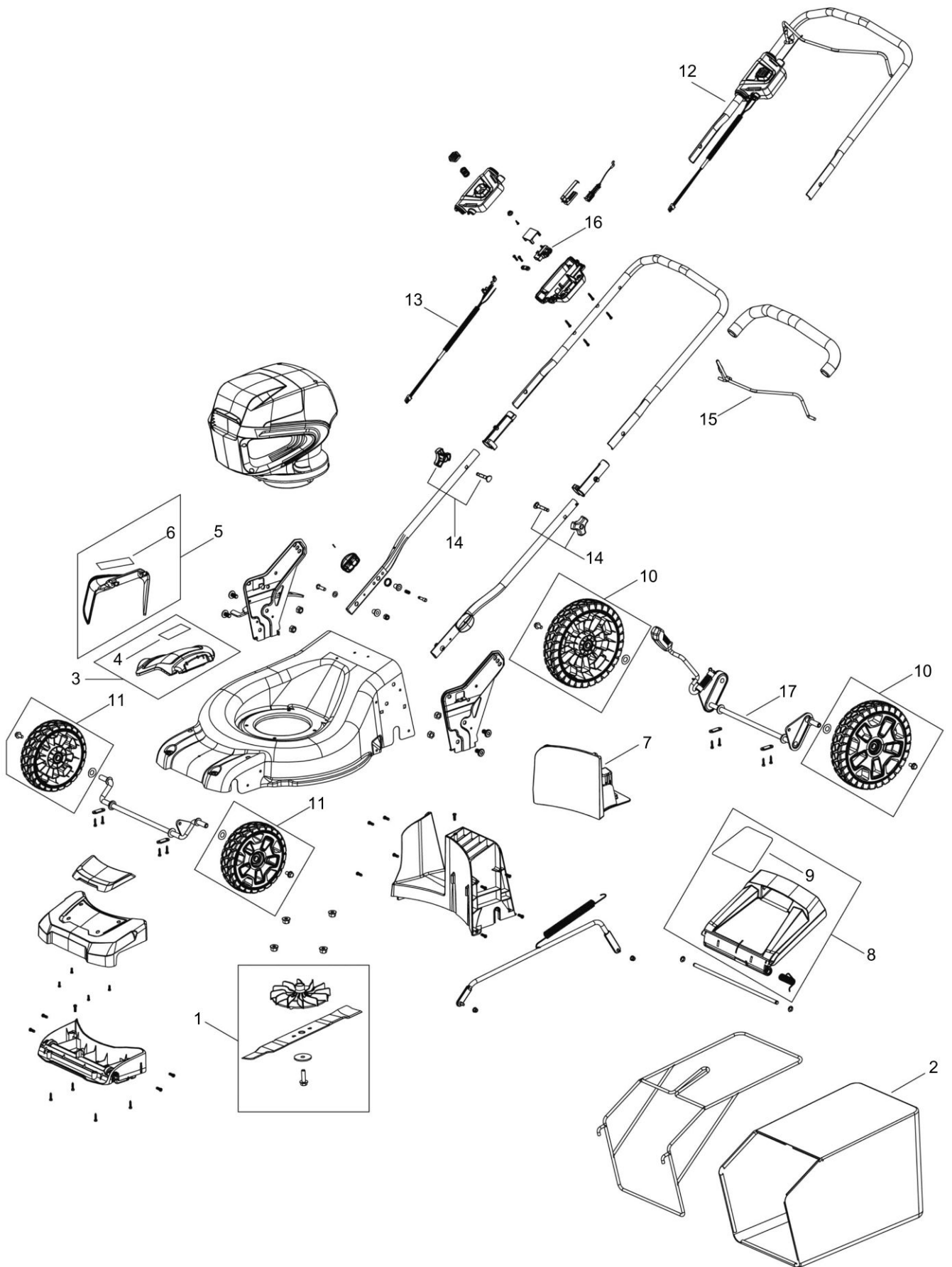

BODY

Key No.	LV (+)	Parts Number	Parts Description	Qty	Standard	Class
1		P022-061290	KIT, BLADE	1		A
2		P022-061300	BAG,DUST	1		D
3		P022-061310	DOOR,SIDE	1		C
4	+	P022-061320	LABEL, CAUTION	1		D
5		P022-061330	SIDE DISCHARGE CHUTE	1		C
6	+	P022-061320	LABEL, CAUTION	1		D
7		P022-061150	PLAG	1		C
8		P022-061160	DOOR	1		C
9	+	P022-061170	LABEL, CAUTION	1		D
10		P022-061180	WHEEL,REAR KIT	2		A
11		P022-061350	WHEEL,FRONT KIT	2		A
12		P022-061200	HANDLE,ASY UPPER	1		C
13		P022-061370	HARNESS, WIRE	1		B
14		P022-061220	KNOB KIT	2		C
15		P022-061230	LEVER, SWITCH	1		C
16		P022-061240	SWITCH	1		B
17		P022-061250	LEVER,ADJUST	1		C

Class : Consumable class

A:Fast moving parts B:Semi-fast moving parts C:Slow moving parts D:Order only as needed

COVER

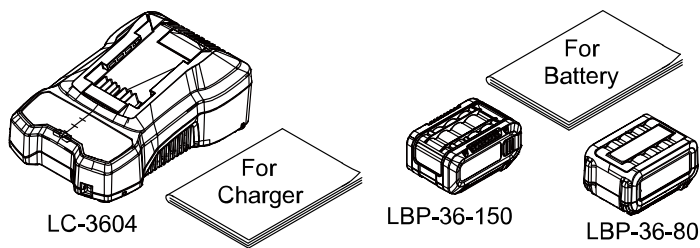
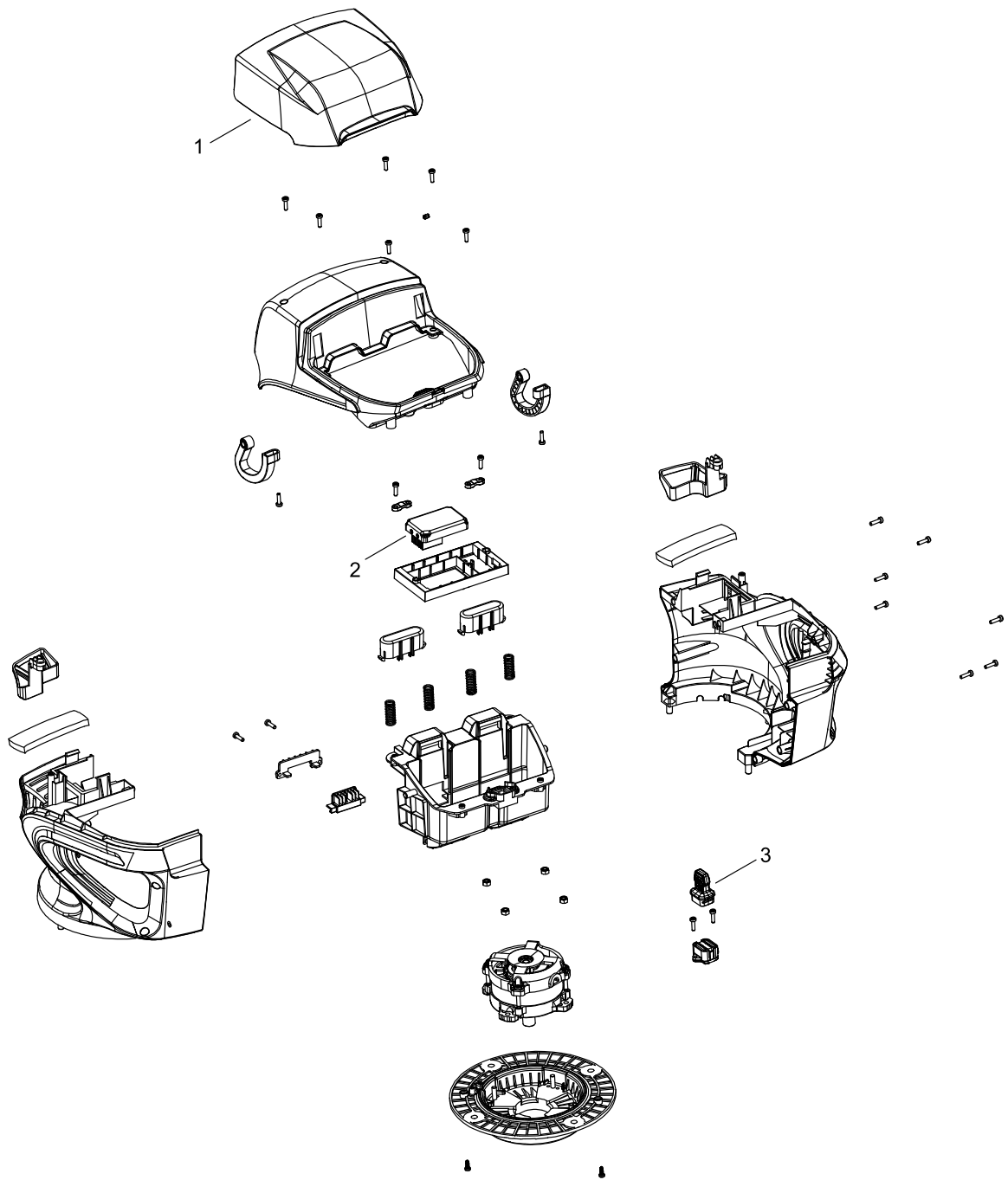

* Batteries and charger are handled as accessories instead of spare parts.
Please place an order of batteries and charger at the same time as unit order.

COVER

Key No.	LV (+)	Parts Number	Parts Description	Qty	Standard	Class
1		P022-061260	COVER	1		C
2		P022-061270	BOARD,ASM CONTROL	1		D
3		P022-061280	KEY,SWITCH	1		D

Class : Consumable class

A:Fast moving parts B:Semi-fast moving parts C:Slow moving parts D:Order only as needed

NUMERICAL PARTS INDEX

Part No	Part description	Page
P022-061150	PLAG	2
P022-061160	DOOR	2
P022-061170	LABEL, CAUTION	2
P022-061180	WHEEL, REAR KIT	2
P022-061200	HANDLE, ASY UPPER	2
P022-061220	KNOB KIT	2
P022-061230	LEVER, SWITCH	2
P022-061240	SWITCH	2
P022-061250	LEVER, ADJUST	2
P022-061260	COVER	4
P022-061270	BOARD, ASM CONTROL	4
P022-061280	KEY, SWITCH	4
P022-061290	KIT, BLADE	2
P022-061300	BAG, DUST	2
P022-061310	DOOR, SIDE	2
P022-061320	LABEL, CAUTION	2
P022-061330	SIDE DISCHARGE CHUTE	2
P022-061350	WHEEL, FRONT KIT	2
P022-061370	HARNES, WIRE	2