

English.....1
Français.....FR_1
Italiano.....IT_1

SHINDAIWA OWNER'S/OPERATOR'S MANUAL

M2510 MULTIPURPOSE TOOL CARRIER



WARNING!

- Read this manual and the manuals provided with the Shindaiwa Splitboom Attachment series and familiarize yourself with its contents.
- Do not operate or service this machine unless you clearly understand this manual.
- This machine is designed for cutting branches, grass, weeds and brush. Use only for designated purpose.
- Minimize the risk of injury to yourself and others.
- Always wear eye protection and a safety helmet when operating this machine.
- Keep this manual available at all times so that you can reference it whenever you have a question about the use of this unit.

shindaiwa®

Part Number 65040-94310 Rev. 2/08

Introduction

The Shindaiwa 2510-series hand held power equipment has been designed and built to deliver superior performance and reliability without compromise to quality, comfort, safety or durability.

Shindaiwa engines represent the leading edge of high-performance engine technology, delivering exceptionally high power with remarkably low displacement and weight. As an owner/operator, you'll soon discover for yourself why Shindaiwa is simply in a class by itself!

IMPORTANT!

The information contained in this owner's/operator's manual describes M2510 Multipurpose Tool Carrier available at the time of publication.

Shindaiwa Inc. reserves the right to make changes to products without prior notice, and without obligation to make alterations to units previously manufactured.

Attention Statements

Throughout this manual are special "attention statements".



WARNING!

A statement preceded by the triangular attention symbol and the word "WARNING" contains information that should be acted upon to prevent serious bodily injury.

CAUTION!

A statement preceded by the word "CAUTION" contains information that should be acted upon to prevent mechanical damage.

IMPORTANT!

A statement preceded by the word "IMPORTANT" is one that possesses special significance.

NOTE:

A statement preceded by the word "NOTE" contains information that is handy to know and may make your job easier.



Read and follow this manual, make sure anyone using the trimmer does likewise. Failure to do so could result in serious personal injury or machine failure. Keep this manual for future reference.



Always wear a hard hat to reduce the risk of head injuries during operation of this machine. In addition, always wear eye and hearing protection. Shindaiwa recommends wearing a face shield as additional face and eye protection.

Wear heavy duty, non-slip gloves. Safety tip shoes or boots with non-slip sole should be worn.



Never operate power equipment of any kind if you are tired or if you are under the influence of alcohol, drugs, medication or any other substance that could affect your ability or judgement.



Sound Power Level (measured in accordance with 2000/14/EC)

Contents

PAGE

Attention Statements.....	2
Safety Instructions	3
Product Description.....	4
Specifications.....	4
Assembly.....	5
Installing a Tool Attachment.....	5
Removing a Tool Attachment.....	5
Mixing Fuel.....	6
Filling the Fuel Tank.....	6
Starting the Engine	7
Stopping the Engine.....	8
Maintenance	9
Long Term Storage	11
Troubleshooting Guide	12
Declaration of Conformity.....	15

IMPORTANT!

The operational procedures described in this manual are intended to help you get the most from this unit as well as to protect you and others from harm. These procedures are guidelines for safe operation under most conditions, and are not intended to replace any safety rules and/or laws that may be in force in your area. If you have questions regarding your 2510-series hand held power equipment, or if you do not understand something in this manual, your Shindaiwa dealer will be glad to assist you. You may also contact Shindaiwa, Inc. at the address printed on the back of this Manual.

Safety Instructions



WARNING!

Never operate power equipment of any kind if you are tired or if you are under the influence of alcohol, drugs, medication or any other substance that could affect your ability or judgement.



Attachments for the Multipurpose Tool Carrier operate at very high speeds and can do serious damage or injury if they are misused or abused. *Never allow a person without training or instruction to operate this unit!*

Stay Alert

You must be physically and mentally fit to operate this unit safely.



WARNING!

Never make unauthorized attachment installations. Do not use attachments not approved by Shindaiwa for use on this unit.



WARNING!

Use Good Judgement

ALWAYS wear eye protection to shield against thrown objects.

ALWAYS wear hearing protection devices when operating this unit.

NEVER operate the engine when transporting the unit. Make sure cutter safety guards are in place when transporting this unit.

NEVER operate the engine indoors! Make sure there is always good ventilation. Fumes from engine exhaust can cause serious injury or death.

ALWAYS make sure there are no missing or loose fasteners and that the stop switch and throttle controls are working properly.

ALWAYS use the proper cutting tool for the job.

ALWAYS clear your work area of trash or hidden debris that could be thrown back at you or toward a bystander.

ALWAYS make sure the cutting attachment tool is properly installed and firmly tightened before operation.

NEVER use a cracked or warped cutting attachment: replace it with a serviceable one and make sure it fits properly.

ALWAYS stop the engine immediately if it suddenly begins to vibrate or shake. Inspect for broken, missing or improperly installed parts or attachments.

ALWAYS keep the unit as clean as practical. Keep it free of loose vegetation, mud, etc.

NEVER extend trimming line beyond the length specified for your unit.

ALWAYS hold the unit firmly with both hands when cutting or trimming, and maintain control at all times.

ALWAYS keep the handles clean.

ALWAYS disconnect the spark plug wire before performing any maintenance work.

BEFORE starting the engine make sure the cutting attachment is not contacting anything.

ALWAYS stop the engine immediately and check for damage if you strike a foreign object or if the unit becomes tangled. Do not operate with broken or damaged equipment.

ALWAYS maintain the Multipurpose Engine according to this owner's manual and follow the recommended scheduled maintenance.

NEVER allow the engine to run at high RPM without a load. Doing so could damage the engine.

ALWAYS use genuine Shindaiwa parts and accessories when repairing or maintaining this unit.

NEVER modify or disable any of the unit's devices. Use only Shindaiwa genuine parts for repairs and maintenance.

WHEN transporting the unit in a vehicle, tie it down securely to prevent damage and fuel spillage.

NEVER permit a person without training or instruction to repair or operate this machine.

Safety Labels

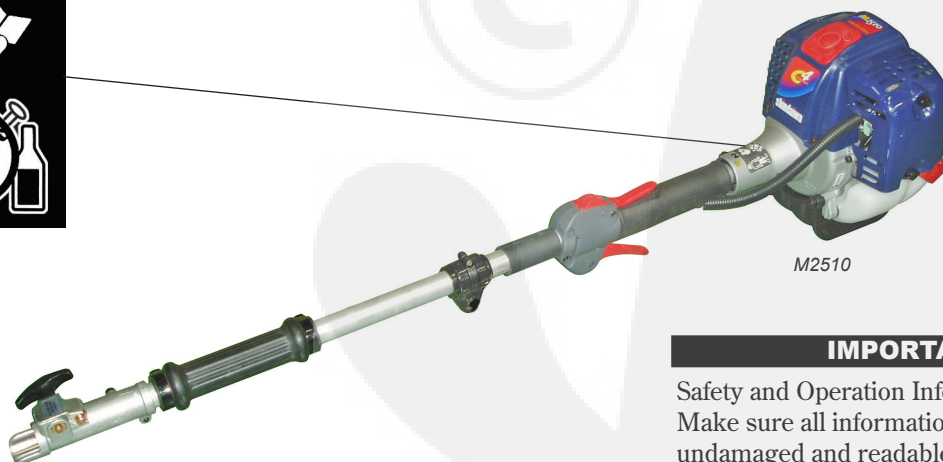

M2510

IMPORTANT!

Safety and Operation Information Labels: Make sure all information labels are undamaged and readable. Immediately replace damaged or missing information labels. New labels are available from your local authorized Shindaiwa dealer.

Figure 1

Product Description

Using the accompanying illustrations as a guide, familiarize yourself with this unit and its various components. See Figure 2. Understanding your unit helps ensure top performance, long service life and safer operation.

WARNING! Do not make unauthorized modifications or alterations to any of these units or their components.

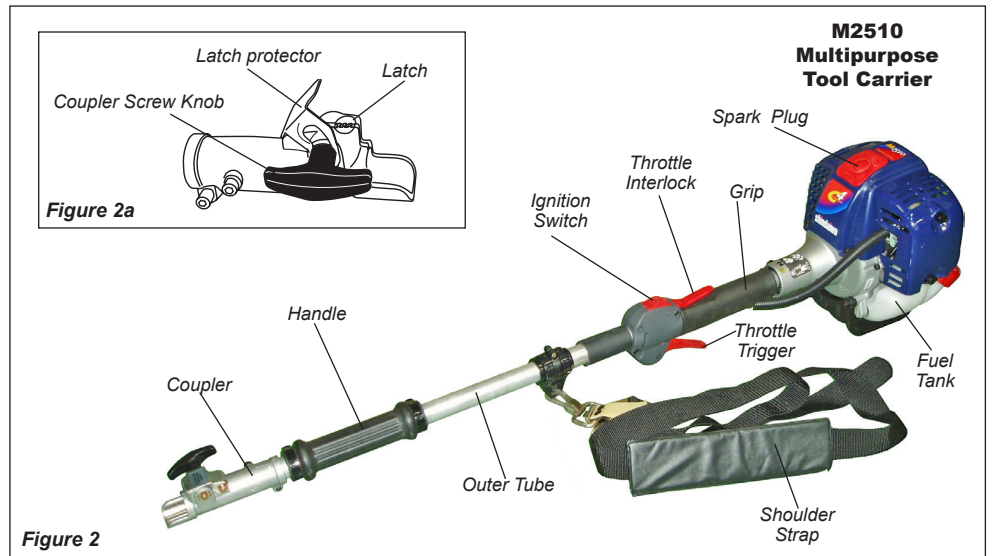

Specifications

Engine Name	M2510/EC2	Fuel tank capacity	600 cm ³
Engine model.....	SF2510EC2	Fuel/oil ratio.....	50:1 with ISO-L-EGD or JASO FC class 2-cycle mixing oil*
Engine type.....	4-cycle, vertical cylinder, air cooled	Carburetor	Walbro WYL diaphragm-type
Dry weight (less attachments)	4.3 kg	Ignition	Fully electronic, program controlled
Dimensions (L xHxW)	1038 mm x 213 mm x 250 mm	Spark plug.....	NGK CMR5H
Displacement	24.5 cm ³	Air filter	Dry element
Bore x stroke.....	34 x 27 mm	Starting method	Recoil
Engine Speed at Maximum Power Output	8,000 min ⁻¹	Stopping method	Slide switch
Maximum power output.....	0.8 kW	Cooling system	Forced air
Engine speed at idling	3,000 min ⁻¹	Transmission type	Automatic, centrifugal clutch with bevel gear
Maximum engine speed	10,500 min ⁻¹		

With Shindaiwa SBA-TX24 Splitboom Attachment

Sound Pressure Level *(average data between at Idling and at WOT) Note 1.....	92 dB (A)
Sound Power Level ** (average data between at Idling and at WOT) Note 1	101 dB (A)
Vibration Level** (Idling [Front/Rear]) Note 1.....	4.0/1.1 m/s ²
(WOT [Front/Rear]).....	5.1/8.0 m/s ²
Sound Pressure Level *(average data between at Idling and at WOT) Note 2.....	95 dB (A)
Sound Power Level ** (average data between at Idling and at WOT) Note 2.....	105 dB (A)
Vibration Level*** (Idling [Front/Rear]) Note 2.....	1.0/1.2 m/s ²
(WOT [Front/Rear]) Note 2	3.7/6.0 m/s ²

Specifications are subject to change without notice.

*Sound Pressure Level: In accordance with EN ISO 11806 and ISO 22868 (average data between Idling and a WOT)

**Sound Power Level: In accordance with EN ISO 11806 and ISO 22868 (average data between at Idling and at WOT)
 ***Vibration Level: In accordance with EN ISO 11806 and ISO 22867.

Note 1: 8-tooth blade equipped
 Note 2: Trimmer head equipped

With Shindaiwa SBA-P24 Splitboom Attachment (254 mm Guide Bar Equipped)

Sound Pressure Level *(Idling).....	70 dB (A)
(WOT).....	95 dB (A)
Sound Power Level ** (Idling)	84 dB (A)
(WOT).....	106 dB (A)
Vibration Level*** (Idling [Front/Rear])	1.0/1.2 m/s ²
(WOT [Front/Rear]).....	4.1/7.5 m/s ²

Specifications are subject to change without notice.

*Sound Pressure Level: In accordance with ISO 11680-1

**Sound Power Level: In accordance with ISO 11680-1
 ***Vibration Level: In accordance with ISO 11680-1

With Shindaiwa SBA-AH2422 Splitboom Attachment

Sound Pressure Level *(Idling).....	71 dB (A)
(WOT).....	90 dB (A)
Sound Power Level ** (Idling)	84 dB (A)
(WOT).....	104 dB (A)
Vibration Level*** (Idling [Front/Rear])	0.9/1.5 m/s ²
(WOT [Front/Rear]).....	5.8/8.3 m/s ²

Specifications are subject to change without notice.

*Sound Pressure Level: In accordance with ISO 11680-1

**Sound Power Level: In accordance with ISO 11680-1
 ***Vibration Level: In accordance with ISO 11680-1

Assembly

Prior to Assembly

Before assembling, make sure you have all the components required for a complete unit:

- Engine/Outer tube assembly
- Strap

■ Kit containing this owner/operator's manual and tool kit for routine maintenance. Tool kits vary by model and may include a hex wrench set, a spark plug/screwdriver combination wrench, and a spanner.

IMPORTANT!

The terms "left", "left-hand", and "LH"; "right", "right-hand", and "RH"; "front" and "rear" refer to directions as viewed by the operator during normal operation.

Installing a Tool Attachment

1. Place the M2510 Multipurpose Tool Carrier and the Tool Assembly on a clean, flat surface so that both assemblies fit end to end.

The M2510 assembly should be facing up and the tool assembly should be positioned with the locking hole in the tube end facing up. See Figure 3.

CAUTION!

Keep the open ends of the tubes clean and free of impurities!

2. Slip off the protective covers from the ends of both tubes, and loosen the coupler screw knob.
3. Insert the tool assembly into the coupler, with the tool decal facing up, until the line of the decal is flush with the end of the coupler.
4. Twist the tool assembly back and forth until you are sure it snaps in place by the coupler latch. See Figure 3.
5. When the two tube halves are locked together, press down on the spring-loaded latch protector and tighten the coupler screw knob. See Figure 4.

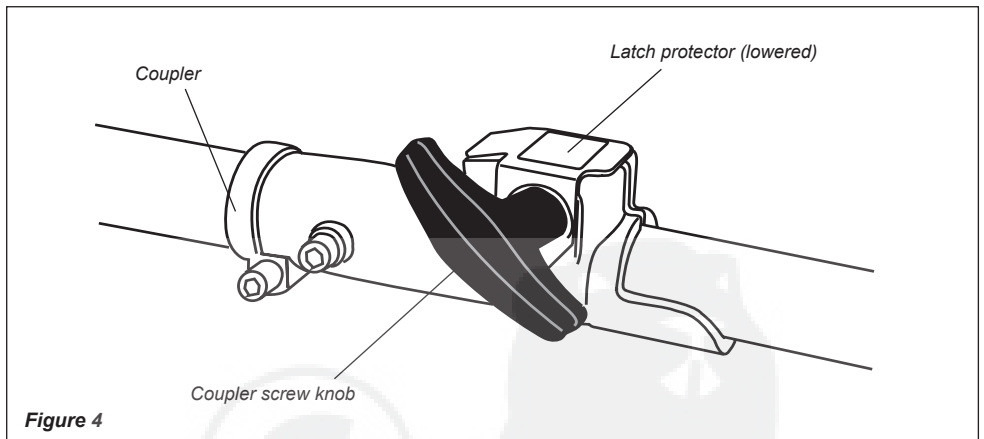
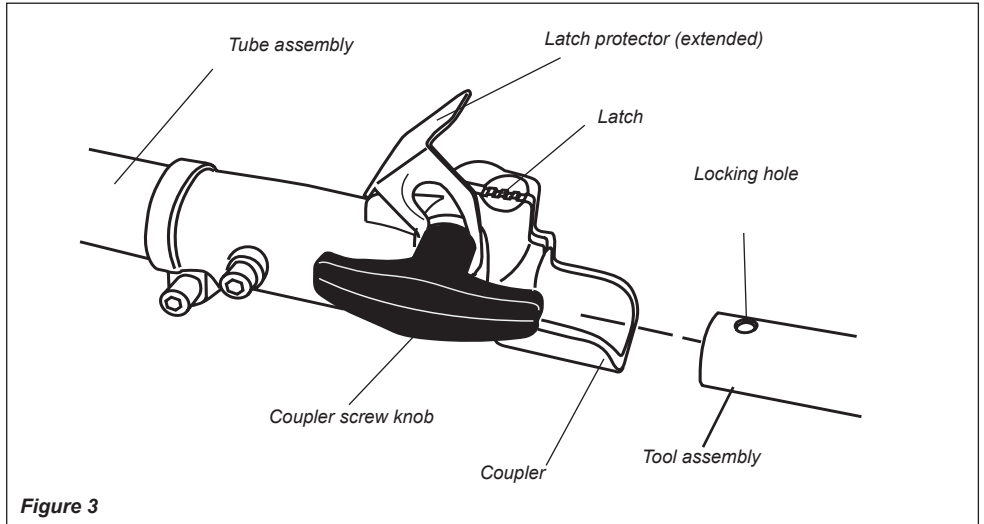

Removing a Tool Attachment

1. With the unit on a clean, flat surface, loosen the coupler screw. The spring-loaded coupler protector should pop up.
2. Press down on the latch with your finger or thumb. This releases the coupler lock. See Figure 5.
3. Pull the tool assembly out of the coupler.

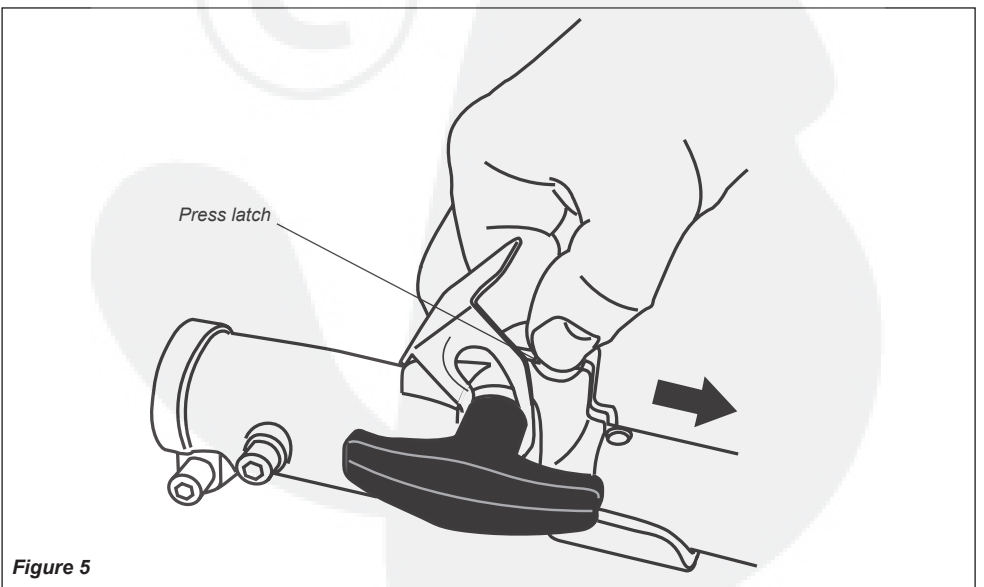

Mixing Fuel

CAUTION!

Never use any type of gasoline containing more than 10% alcohol by volume! Some types of gasoline contain alcohol as an oxygenate. Oxygenated gasoline may cause increased operating temperatures. Under certain conditions, alcohol-based gasoline may also reduce the lubricating qualities of some 2-cycle mixing oils. Generic oils and some outboard oils may not be intended for use in high-performance C4 type engines, and should never be used in your Shindaiwa engine.

- Use only fresh, clean unleaded gasoline with a pump octane of 87 or higher.
- Mix all fuel with a 2-cycle air-cooled mixing oil that meets or exceeds ISO-L-EGD and/or JASO FC classified oils at 50:1 gasoline/oil ratio.

CAUTION!

This engine is designed to operate on a 50:1 mixture consisting of unleaded gasoline and ISO-L-EGD or JASO FC class 2-cycle mixing oil only. Use of non-approved mixing oils can lead to excessive carbon deposits.

Examples of 50:1 mixing quantities

Gasoline liters	2-cycle engine oil milliliters
2.5 - 1	50 ml
5 - 1	100 ml
10 - 1	200 ml
20 - 1	400 ml

IMPORTANT!

Mix only enough fuel for your immediate needs! If fuel must be stored longer than 30 days and  oil with fuel stabilizer is not used, it should first be treated with a fuel stabilizer such as StaBil™.

shindaiwa

 is a registered JASO FC classified oil and also meets or exceeds ISO-L-EGD performance requirements. Shindaiwa One is recommended for use in all Shindaiwa low emissions engines. Shindaiwa One also includes a fuel stabilizer.

Filling the Fuel Tank



WARNING! Minimize the risk of fire!

- STOP engine before refueling.
- ALWAYS allow the engine to cool completely before refueling.
- Wipe all spilled fuel and move the engine at least 10 feet (3 meters) from the fueling point and source before restarting.
- NEVER start or operate this unit if there is a fuel leak.
- NEVER start or operate this unit if the carburetor, fuel lines, fuel tank and/or fuel tank cap are damaged.
- NEVER smoke or light any fires near the engine or fuel source.
- NEVER place any flammable material near the engine muffler.
- NEVER operate the engine without the muffler and spark arrester in good working condition.

1. Place the unit on a flat, level surface.
2. Clear any dirt or other debris from around the fuel filler cap.
3. Remove the fuel cap, and fill the tank with clean, fresh fuel.
4. Reinstall the fuel filler cap and tighten firmly.

Starting the Engine



WARNING!

The cutting attachment may rotate when the engine is started!



WARNING!

Never start the engine without the tool assembly and cutting attachments installed to the engine. Failure to do so could damage the engine and increase unexpected risk to the operator and any bystander.



WARNING!

Never start the engine from the operating position.

IMPORTANT!

Engine ignition is controlled by a two position switch mounted on the throttle housing labeled, "I" for ON or START and "O" for OFF or STOP.

1. Slide the ignition switch to the "ON" position. See Figure 6.

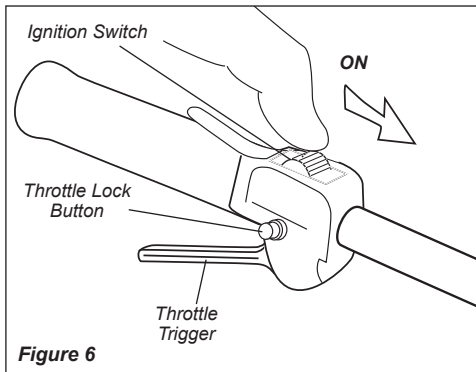

2. Set the throttle lever to the "fast idle";
 - a. Squeeze the throttle lever toward the hand grip on the shaft tube.
 - b. Depress and hold the throttle lock button.
 - c. While depressing the throttle lock button, release the throttle lever. See Figure 6.
3. Press the primer bulb until fuel can be seen flowing in the transparent return tube.

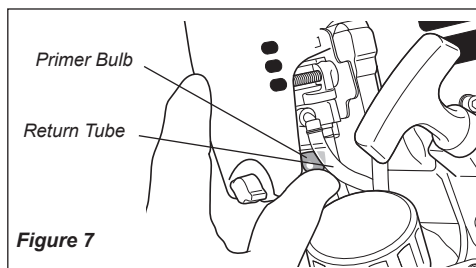

IMPORTANT!

The primer system only pushes fuel through the carburetor. Repeatedly pressing the primer bulb will not flood the engine with fuel.

4. Set the choke lever to the "CLOSED" position if engine is cold.

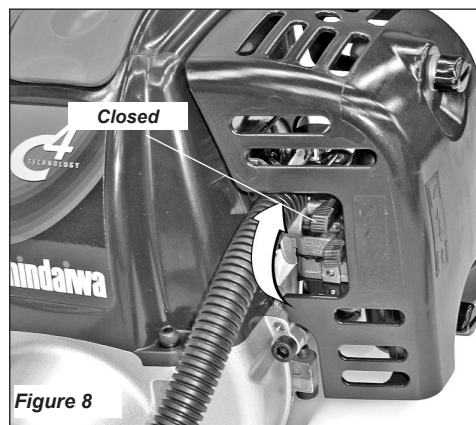

5. While holding the outer tube firmly with your left hand, use your other hand to slowly pull the recoil starter handle until resistance is felt, then pull quickly to start the engine.

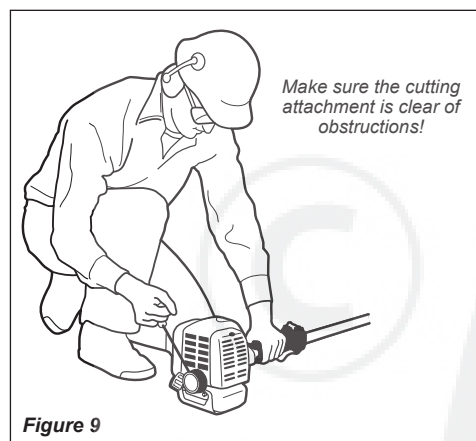

CAUTION!

Do not pull the recoil starter to the end of the rope travel. Pulling the recoil starter to the end of the rope travel can damage the starter.

6. When the engine starts, slowly move the choke lever to the "OPEN" position. See Figure 10. (If the engine stops after the initial start, close the choke and restart.)

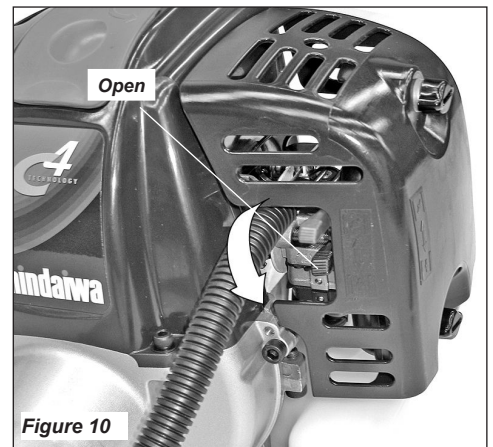

IMPORTANT!

If the engine fails to start after several attempts with the choke in the closed position, the engine may be flooded with fuel. If flooding is suspected, move the choke lever to open position and repeatedly pull the recoil starter to remove the excess fuel and start the engine. If the engine still fails to start, See the section "Starting a Flooded Engine" for instructions.

When the Engine Starts...

- After the engine starts, allow the engine to warm up at idle 2 or 3 minutes before operating the unit.
- After the engine is warm, pick up the unit and clip on the shoulder strap.
- Advancing the throttle makes the cutting attachment turn faster; releasing the throttle permits the attachment to stop turning. If the cutting attachment continues to rotate when the engine returns to idle, carburetor idle speed should be adjusted (see "Adjusting Engine Idle").

Starting A Flooded Engine

1. Slide the ignition switch to the "O" (STOP) position.
2. Disconnect the spark plug lead and use the spark plug wrench to remove the spark plug (turn counter clockwise to remove). If the spark plug is fouled or soaked with fuel, clean the plug as necessary.
3. Open the choke and fully depress the throttle lever with your left hand, then pull the starter handle rapidly with your right hand to clear excess fuel from the combustion chamber.
4. Reinstall the spark plug and tighten it firmly. If a torque wrench is available, torque the spark plug to 170–190 kg/cm.
5. Repeat the starting procedure .
6. If the engine still fails to start, refer to the troubleshooting section near the end of this manual.

Stopping the Engine

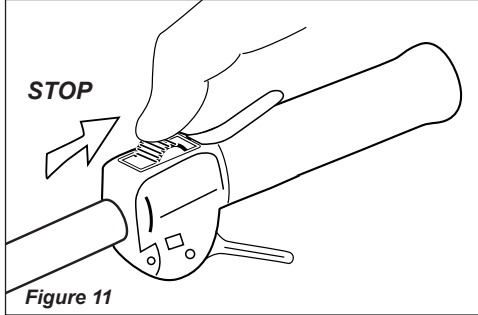

Idle the engine briefly before stopping (about 2 minutes), then slide the ignition switch to the "O" (STOP Engine) position.

Adjusting Engine Idle

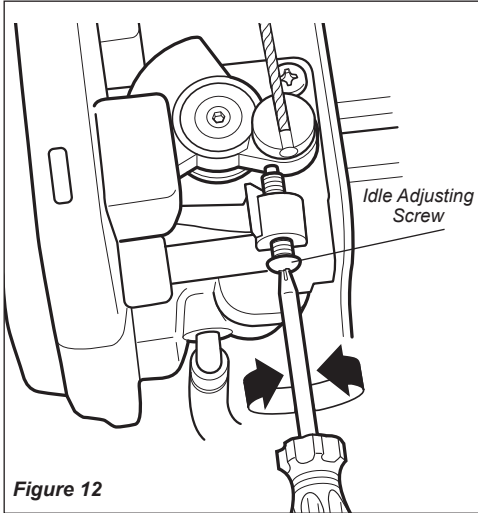

The engine must return to idle speed whenever the throttle lever is released. Idle speed is adjustable, and must be set low enough to permit the engine clutch to disengage the cutting attachment.

Idle Speed Adjustment

1. Place the trimmer on the ground, then start the engine, and then allow it to idle 2-3 minutes until warm.
2. If the attachment rotates when the engine is at idle, reduce the idle speed by turning the idle adjustment screw counter-clockwise. See Figure 12.

If a tachometer is available, the engine idle speed should be final adjusted to 3,000 (± 300) min^{-1} .

IMPORTANT

Carburetor fuel mixture adjustments are preset at factory and cannot be serviced in the field.



WARNING!

The cutting attachment must NEVER rotate at engine idle! If the idle speed cannot be adjusted by the procedure described here, return the unit machine to your Shindaiwa dealer for inspection.

Attaching the Shoulder Strap

To Wear the Shoulder Strap

1. Hook the strap hook to the hanger on the outer tube.
2. Wear the shoulder strap so that the hook stays at your right hand side.
3. Adjust the length of the shoulder strap so that you can hold and operate the machine comfortably.

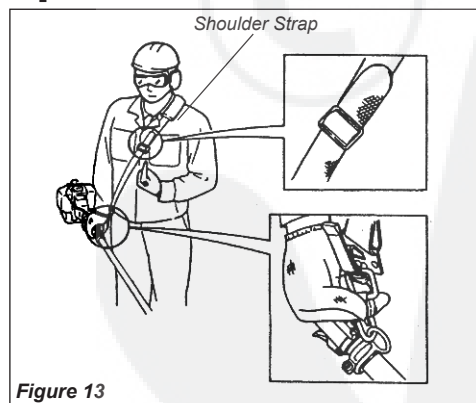

Emergency Release

In case of emergency, strongly pull the white tab at the hook. The machine will be released from the strap.

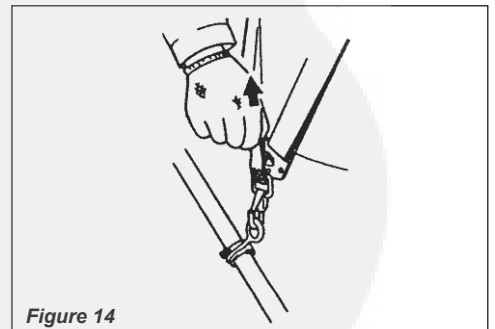

General Maintenance

IMPORTANT!

MAINTENANCE, REPLACEMENT, OR REPAIR OF EMISSION CONTROL DEVICES AND SYSTEM MAY BE PERFORMED BY ANY REPAIR ESTABLISHMENT OR INDIVIDUAL. HOWEVER, WARRANTY REPAIRS MUST BE PERFORMED BY A DEALER OR SERVICE CENTER AUTHORIZED BY SHINDAIWA CORPORATION AND USE OF PARTS THAT ARE NOT EQUIVALENT IN PERFORMANCE AND DURABILITY TO AUTHORIZED PARTS MAY IMPAIR THE EFFECTIVENESS OF THE EMISSION CONTROL SYSTEM AND MAY HAVE A BEARING ON THE OUTCOME OF THE WARRANTY CLAIM.



WARNING!

Before performing any maintenance, repair or cleaning work on the unit, make sure the engine and cutting attachment are completely stopped. Disconnect the spark plug wire before performing service or maintenance work.



WARNING!

Non-standard parts may not operate properly with your unit and may cause damage and lead to personal injury.

Muffler

This unit must never be operated with a faulty or missing spark arrester or muffler. Make sure the muffler is well secured and in good condition. A worn or damaged muffler is a fire hazard and may also cause hearing loss.

Spark Plug

Keep the spark plug and wire connections tight and clean.

Fasteners

Make sure nuts, bolts, and screws (except carburetor adjusting screws) are tight.

Daily Maintenance

Prior to each work day, perform the following:

- Remove dirt or debris from the engine, check the cooling fins and air cleaner for clogging and clean them as necessary.
- Carefully remove any accumulation of dirt or debris from the muffler or the fuel tank. Dirt build-up in these areas could cause engine overheating, induce premature wear, or create a fire hazard.

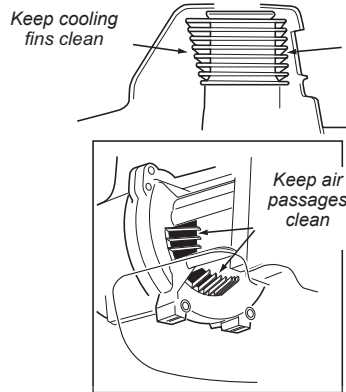

Figure 15

- Check for loose or missing screws or components. Make sure the cutting attachment is securely fastened.
- Check the entire unit for leaking fuel or grease.

10-Hour Maintenance

(More frequently in dusty conditions)

1. Remove the air cleaner cover by loosening the two thumbscrews. See Figure 16A.
2. Remove and inspect the pre-filter. If the pre-filter is torn or otherwise damaged, replace it with a new one. See Figure 16B.
3. Clean the pre-filter with soap and water. Let dry before reinstalling.
4. Inspect the air cleaner element. If the element is damaged or distorted, replace it with a new one.
5. Tap filter gently on a hard surface to dislodge debris from element or use compressed air from the inside to blow debris out and away from the air filter element.

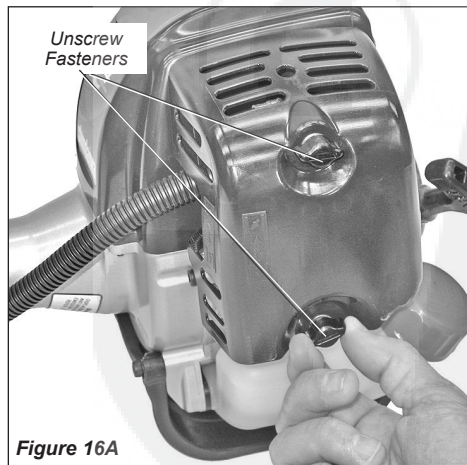

Figure 16A

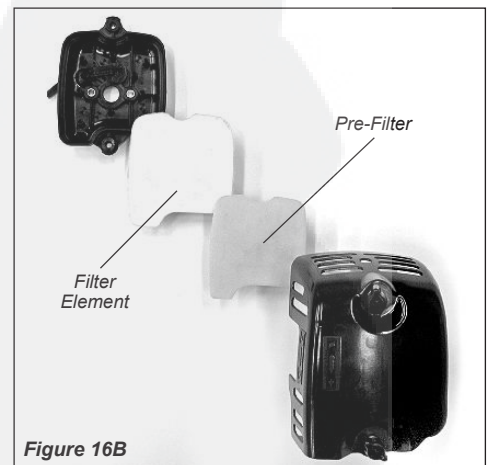

Figure 16B

6. Install the filter element, pre-filter and cover in the reverse order of removal.

IMPORTANT!

Direct the air stream at the inside face of the filter only!

CAUTION!

Never operate the unit if the air cleaner assembly is damaged or missing!

10/15-Hour Maintenance

Every 10 to 15 hours of operation:

- Remove and clean the spark plug. Adjust the spark plug electrode gap to 0.6 - 0.7 mm.

If the spark plug must be replaced, use only an NGK CMR5H or equivalent resistor type spark plug of the correct heat range. See Figure 17.

CAUTION!

Before removing the spark plug, clean the area around the plug to prevent dirt and debris from getting into the engine's internal parts.

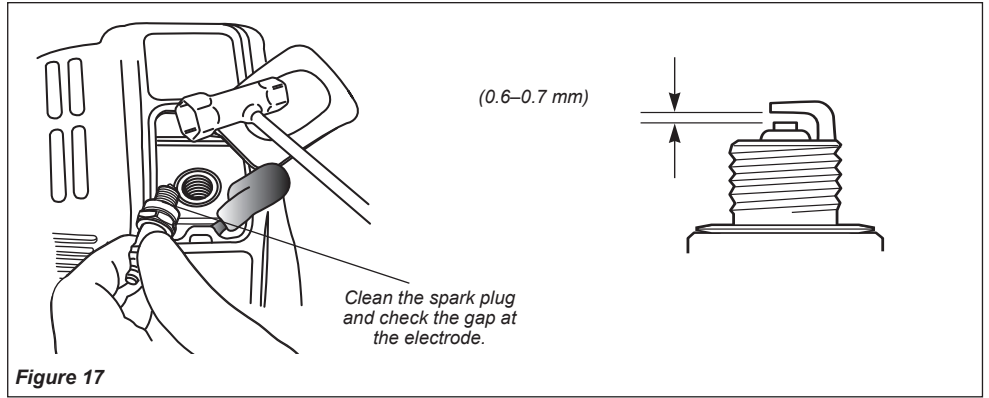

Figure 17

50-hour Maintenance

Every 50 hours of operation (more frequently in dusty or dirty conditions):

- Remove and clean the cylinder cover and clean grass and dirt from the cylinder fins.
- Use a hooked wire to extract the fuel filter from inside the fuel tank. See Figure 18. Remove and replace the filter element.

CAUTION!

Make sure you do not pierce the fuel line with the end of the hooked wire. The line is delicate and can be damaged easily.

- Before reinstalling the new filter element, inspect the condition of all the fuel system components (fuel pick-up line, fuel return line, tank vent line, tank vent, fuel cap and fuel tank).

If damage, splitting or deterioration is noted, the unit should be removed from service until it can be inspected or repaired by a Shindaiwa-trained service technician.

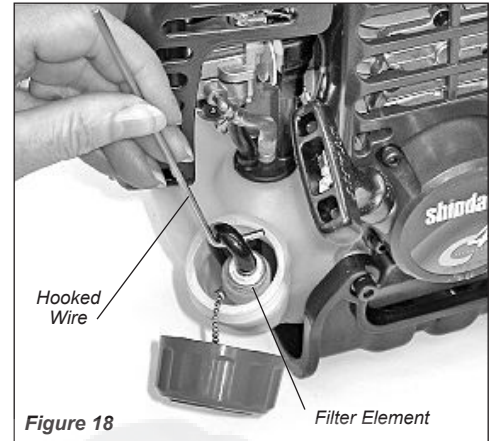

Figure 18

139-150 Hour Maintenance

After first 139 hours, then every 150 hours thereafter:

- Combustion chamber should be decarbonized, and the valve clearance should be adjusted. It is highly recommended that this is done by a Shindaiwa-trained service technician.
- Replace the spark plug annually: Use only NGK CMR5H or equivalent resistor type spark plug of the correct heat range. Set spark plug electrode gap to 0.6 - 0.7 mm.

Muffler Maintenance

If the engine becomes sluggish and low on power, check and clean the spark arrester screen.



WARNING!

Never operate the unit with a damage or missing muffler or spark arrester! Operating with a missing or damaged spark arrester is a fire hazard and could also damage your hearing.

1. With a 3 mm hex wrench remove the 4 engine cover screws and the engine cover. See Figure 19.
2. With a 4 mm hex wrench remove the 3 muffler bolts and the muffler. See Figure 19.
3. With a small flat bladed screwdriver remove the 2 screws holding the spark arrester screen and cover to the muffler. See Figure 19.
4. Remove the screen and clean it with a stiff bristle brush.

Long Term Storage

Whenever the unit will not be used for 30 days or longer, use the following procedures to prepare it for storage:

- Clean external parts thoroughly and apply a light coating of oil to all metal surfaces.
- Drain all the fuel from the fuel tank.

IMPORTANT!

All stored fuels should be stabilized with a fuel stabilizer such as STA-BIL™, if  oil with fuel stabilizer is not used.

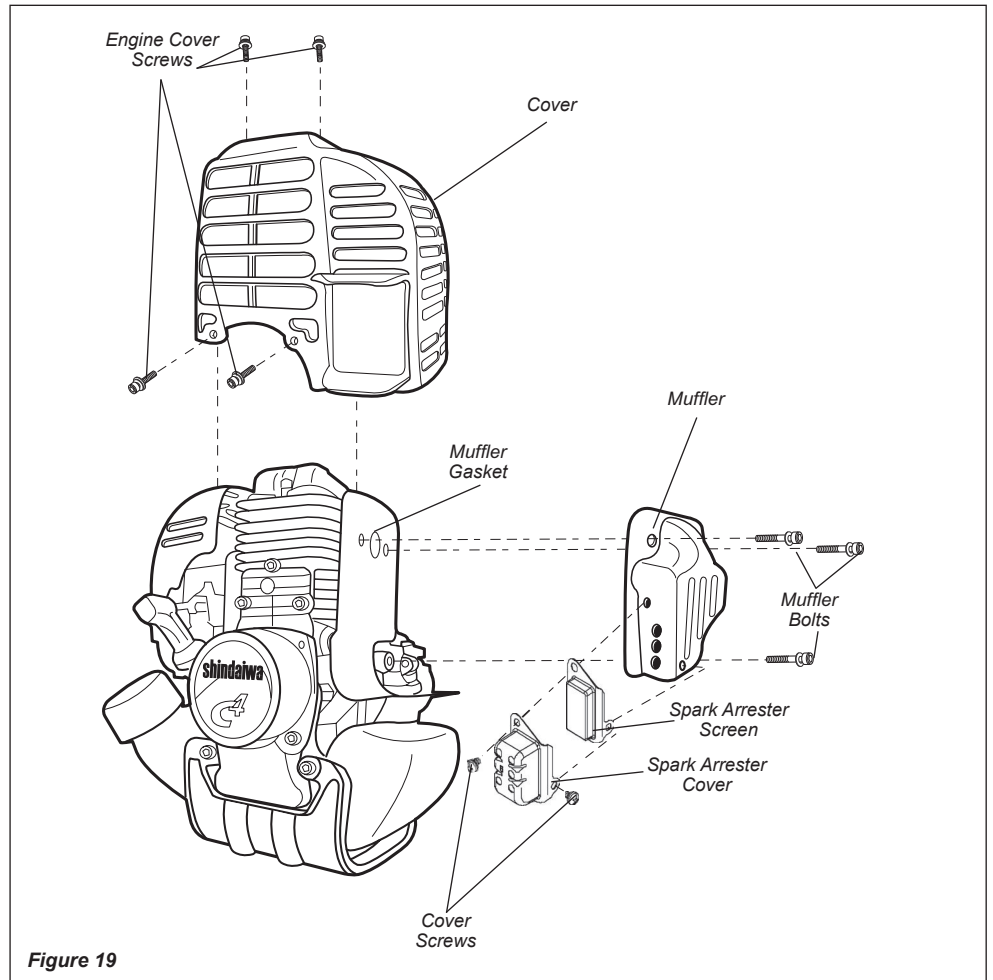

Figure 19

5. Inspect the cylinder exhaust port for any carbon buildup.
6. Reassemble the spark arrester, muffler and engine cover in the reverse order of disassembly.

IMPORTANT!

If you note excessive carbon buildup, consult with an authorized Shindaiwa servicing dealer.

CAUTION!

Gasoline stored in the carburetor for extended periods can cause hard starting and could also lead to increased service and maintenance cost.

Remove the remaining fuel from the fuel lines and carburetor.

1. Prime the primer bulb until no more fuel is passing through.
2. Start and run the engine until stops running.
3. Repeat steps 1 and 2 until the engine will no longer start.

- Remove the spark plug and pour about 1/4 ounce of 2-cycle mixing oil into the cylinder through the spark plug hole. Slowly pull the recoil starter 2 or 3 times so oil will evenly coat the interior of the engine. Reinstall the spark plug.
- Before storing the unit, repair or replace any worn or damaged parts.
- Remove the air cleaner element from the carburetor and clean it thoroughly with soap and water. Let dry and reassemble the element.
- Store the unit in a clean, dust-free area.

What To Check	Possible Cause	Remedy
<p>Does the engine crank?</p> <p>NO →</p> <p>YES ↓</p>	<p>Faulty recoil starter.</p> <p>Fluid in the crankcase.</p> <p>Internal damage.</p>	<p>Consult with an authorized servicing dealer.</p>
<p>Good compression?</p> <p>NO →</p> <p>YES ↓</p>	<p>Loose spark plug.</p> <p>Excess wear on cylinder, piston, rings.</p> <p>Valves not seating.</p>	<p>Tighten and re-test.</p> <p>Consult with an authorized servicing dealer.</p>
<p>Does the tank contain fresh fuel of the proper grade?</p> <p>NO →</p> <p>YES ↓</p>	<p>Fuel incorrect, stale, or contaminated; mixture incorrect.</p>	<p>Refill with fresh, clean unleaded gasoline with a pump octane of 87 or higher mixed with 50:1 Shindaiwa Premium 2-cycle mixing oil or with an equivalent high quality 2-cycle mixing oil.</p>
<p>Is fuel visible and moving in the return line when priming?</p> <p>NO →</p> <p>YES ↓</p>	<p>Check for clogged fuel filter and/or vent.</p>	<p>Replace fuel filter or vent as required. Restart.</p>
<p>Is there spark at the spark plug wire terminal?</p> <p>NO →</p> <p>YES ↓</p>	<p>The ignition switch is in "O" (OFF) position.</p> <p>Shorted ignition ground.</p> <p>Faulty ignition unit.</p>	<p>Move switch to "I" (ON) position and restart.</p> <p>Consult with an authorized servicing dealer.</p>
<p>Check the spark plug.</p>	<p>If the plug is wet, excess fuel may be in the cylinder.</p> <p>The plug is fouled or improperly gapped.</p> <p>The plug is damaged internally or of the wrong size.</p>	<p>Crank the engine with the plug removed, reinstall the plug, and restart.</p> <p>Clean and regap the plug to 0.6mm-0.7mm. Restart.</p> <p>Replace the spark plug. Check the unit Specifications page for the proper spark plug for your unit. Restart.</p>

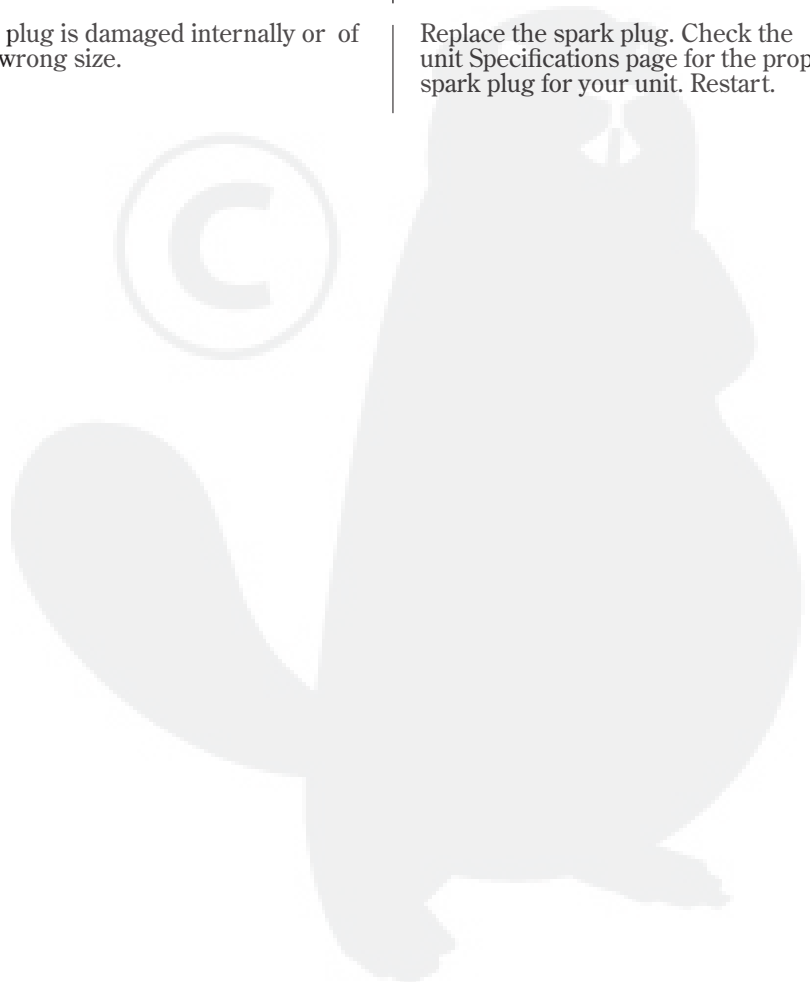
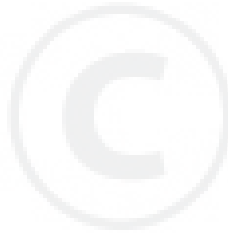

Troubleshooting Guide (continued)

LOW POWER

What To Check	Possible Cause	Remedy
<p>Is the engine overheating?</p>	<p>Operator is overworking the unit.</p> <p>Carburetor mixture is too lean.</p> <p>Improper fuel ratio.</p> <p>Fan, fan cover, cylinder fins dirty or damaged</p>	<p>Cut at slower rate.</p> <p>Consult with an authorized servicing dealer.</p> <p>Refill with clean fresh unleaded gasoline with a pump octane of 87 or higher, mixed with Premium 2-cycle mixing oil at a 50:1 gasoline/oil ratio.</p> <p>Clean, repair or replace as necessary.</p>
<p>Engine is rough at all speeds. May also have black smoke and/or unburned fuel at the exhaust.</p>	<p>Carbon deposits on the piston or in the muffler.</p> <p>Clogged air cleaner element.</p> <p>Loose or damaged spark plug.</p> <p>Air leakage or clogged fuel line.</p> <p>Water in the fuel.</p> <p>Piston seizure.</p> <p>Faulty carburetor and/or diaphragm</p> <p>Valve clearance set incorrectly.</p>	<p>Consult with an authorized servicing dealer</p> <p>Clean or replace the air filter</p> <p>Tighten or replace the spark plug. Restart. Check the "Specifications" page in this manual for the correct spark plug for this unit.</p> <p>Repair or replace fuel filter and/or fuel line.</p> <p>Refill with fresh fuel/oil mixture.</p> <p>Consult with an authorized servicing dealer.</p>
<p>Engine is knocking.</p>	<p>Overheating condition.</p> <p>Improper fuel.</p> <p>Carbon deposits in the combustion chamber.</p> <p>Valve clearance set incorrectly.</p>	<p>Consult with an authorized servicing dealer.</p> <p>Check fuel octane rating; check for presence of alcohol in the fuel. Refuel as necessary.</p> <p>Consult with an authorized servicing dealer.</p>

Troubleshooting Guide (continued)

ADDITIONAL PROBLEMS

What To Check	Possible Cause	Remedy
<p>Poor acceleration.</p>	<p>Clogged air filter. Clogged fuel filter. Lean fuel/air mixture. Idle speed set too low.</p>	<p>Clean or replace the air filter. Replace the fuel filter. Consult with an authorized servicing dealer. Adjust: 3,000 (±300) min⁻¹.</p>
<p>Engine stops abruptly.</p>	<p>Switch turned off. Fuel tank empty. Clogged fuel filter. Water in the fuel. Shorted spark plug or loose terminal. Ignition failure. Piston seizure.</p>	<p>Reset the switch and re-start. Refuel. See "Filling the Fuel Tank" section of manual. Replace fuel filter. Drain; replace with clean fuel. See "Filling the Fuel Tank" section of manual. Clean or replace spark plug. Check the "Specifications" page in this manual for the proper spark plug for your unit. Tighten the terminal. Replace the ignition unit. Consult with an authorized servicing dealer</p>
<p>Engine difficult to shut off.</p>	<p>Ground (stop) wire is disconnected or switch is defective Overheating due to incorrect spark plug Overheated engine.</p>	<p>Test and replace as required. Replace the spark plug. Check the Specifications page in this manual for the proper spark plug for your unit. Idle engine until cool.</p>
<p>Cutting attachment moves at engine idle.</p>	<p>Engine idle too high. Broken clutch spring or worn clutch spring boss. Loose attachment holder.</p>	<p>Set idle: 3,000 (±300) min⁻¹. Replace spring/shoes as required, check idle speed. Inspect and re-tighten holders securely.</p>
<p>Excessive vibration.</p>	<p>Warped or damaged attachment. Loose gearcase. Bent main shaft/worn or damaged bushings.</p>	<p>Inspect and replace attachment as required. Tighten gearcase securely. Inspect and replace as necessary.</p>
<p>Attachment will not rotate.</p>	<p>Shaft not installed in powerhead or gearcase. Broken shaft. Damaged gearcase.</p>	<p>Inspect and reinstall as required. Consult with a authorized servicing dealer.</p>
<p>Top of engine is getting dirty and oily.</p>	<p>Valve cover is leaking.</p>	<p>Consult with an authorized servicing dealer.</p>

DECLARATION OF CONFORMITY

We hereby declare the Shindaiwa Pole Pruner, Model SBA-P24 (SBA-P24/EU with M2510/EC2), meets the following respective requirements.

Council Directives:
2004/108/EC as amended
98/37/EC as amended
2000/14/EC as amended
2004/26/EC as amended

Standard taken:
ISO 12100 - 1&2
ISO 11680 - 1
CISPR 12

Measured sound power level: 107dB(A)

Guaranteed sound power level: 108dB(A)

Serial number: All

Authorized representative in the European community:

Mr. Phil Williams
Worldwide Corporate Advisors LLP
8-10 Hallam Street, Suite 405
London W1W 6JE
TEL: +44 20 3008 8910, FAX: +44 20 3008 8911

Technical documentation is kept by:
K. Maeda DIV. Manager
Engineering Research and Development DIV.

Shindaiwa Corporation

Head office : 6-2-11, Ozuka-Nishi, Asaminami-Ku,
Hiroshima, 731-3167, Japan
TEL: 81-82-849-2003, FAX: 81-82-849-2482

26th December, 2007



T. Yoshitomi
DIV. Manager
Quality Assurance DIV.

Shindaiwa Corporation

Head office : 6-2-11, Ozuka-Nishi, Asaminami-Ku,
Hiroshima, 731-3167, Japan
TEL: 81-82-849-2206, FAX: 81-82-849-2481

DECLARATION OF CONFORMITY

We hereby declare the Shindaiwa Brushcutter, Model SBA-TX24 (SBA-TX24/EU with M2510/EC2), meets the following respective requirements.

Council Directives:	Standard taken:
2004/108/EC as amended	ISO 12100 - 1&2
98/37/EC as amended	ISO 11806
2000/14/EC as amended	CISPR 12
2004/26/EC as amended	

Measured sound power level: 108dB(A)

Guaranteed sound power level: 109dB(A)

Serial number: All

Authorized representative in the European community:

Mr. Phil Williams

Worldwide Corporate Advisors LLP

8-10 Hallam Street, Suite 405

London W1W 6JE

TEL: +44 20 3008 8910, FAX: +44 20 3008 8911

Technical documentation is kept by:

K. Maeda DIV. Manager

Engineering Research and Development DIV.

Shindaiwa Corporation

Head office : 6-2-11, Ozuka-Nishi, Asaminami-Ku,
Hiroshima, 731-3167, Japan

TEL: 81-82-849-2003, FAX: 81-82-849-2482

26th December, 2007



T. Yoshitomi

DIV. Manager

Quality Assurance DIV.

Shindaiwa Corporation

Head office : 6-2-11, Ozuka-Nishi, Asaminami-Ku,
Hiroshima, 731-3167, Japan

TEL: 81-82-849-2206, FAX: 81-82-849-2481

DECLARATION OF CONFORMITY

We hereby declare the Shindaiwa Articulated Hedge trimmer, Model SBA-AH2422 (SBA-AH2422/EU with M2510/EC2), meets the following respective requirements.

Council Directives:
2004/108/EC as amended
98/37/EC as amended
2000/14/EC as amended
2004/26/EC as amended

Standard taken:
ISO 12100 - 1&2
ISO 11680 - 1
CISPR 12

Measured sound power level: 104dB(A)

Guaranteed sound power level: 105dB(A)

Serial number: All

Authorized representative in the European community:

Mr. Phil Williams

Worldwide Corporate Advisors LLP

8-10 Hallam Street, Suite 405

London W1W 6JE

TEL: +44 20 3008 8910, FAX: +44 20 3008 8911

Technical documentation is kept by:

K. Maeda DIV. Manager

Engineering Research and Development DIV.

26th December, 2007



T. Yoshitomi

DIV. Manager

Quality Assurance DIV.



Shindaiwa Corporation

Head office : 6-2-11, Ozuka-Nishi, Asaminami-Ku,
Hiroshima, 731-3167, Japan

TEL: 81-82-849-2003, FAX: 81-82-849-2482

Shindaiwa Corporation

Head office : 6-2-11, Ozuka-Nishi, Asaminami-Ku,
Hiroshima, 731-3167, Japan

TEL: 81-82-849-2206, FAX: 81-82-849-2481

