

22TON VERTICAL LOG SPLITTER

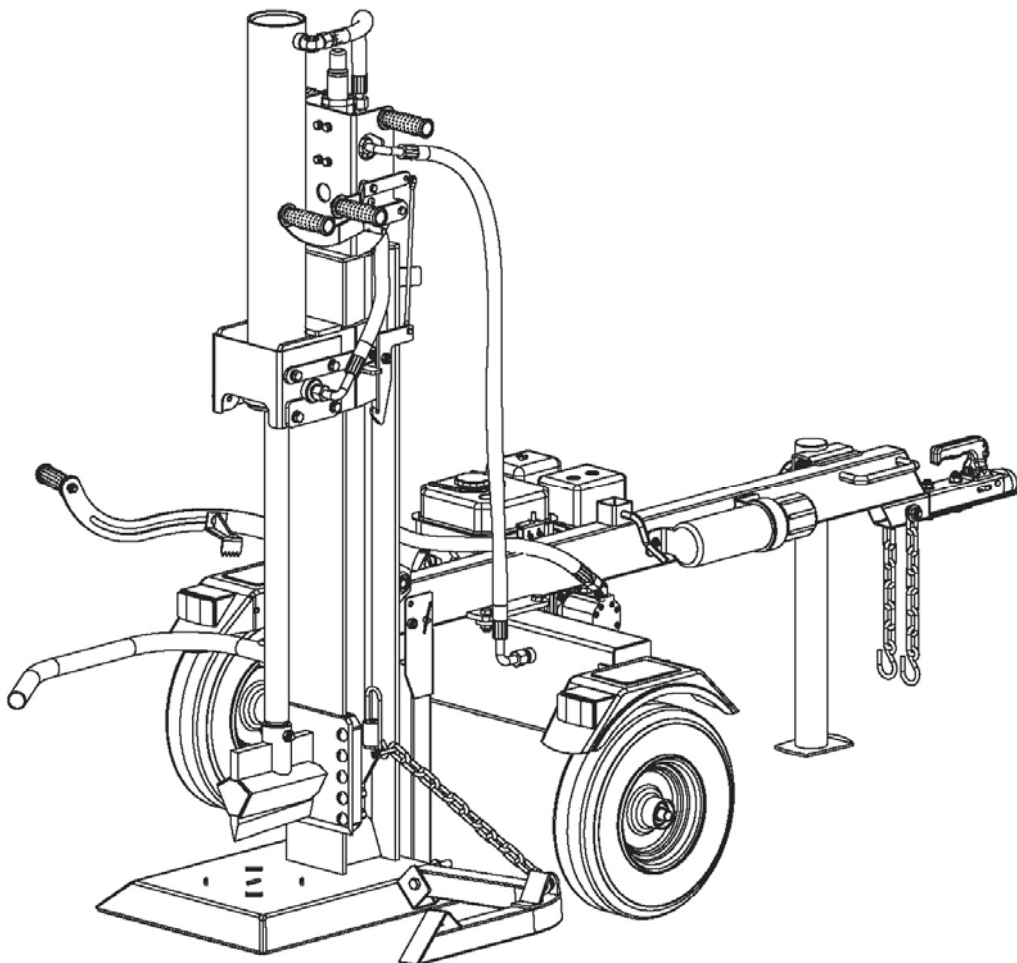

Instruction & Assembly

SAVE THESE INSTRUCTIONS FOR FUTURE REFERENCE

Table of Contents

General Warnings and Rules	3
Hazard Signal Word Definitions.....	4
Controls and Features Identification.....	5
Assembly Instructions	7
Operation Instructions	12
Maintenance and Storage	18
Troubleshooting.....	19
Specification	20
Parts Drawing & Parts List	21

GENERAL WARNINGS

READ and UNDERSTAND this manual completely before using 22 Ton Log Splitter.

Operator must read and understand all safety and warning information, operating instructions, maintenance and storage instructions before operating this equipment. Failure to properly operate and maintain the log splitter could result in serious injury to the operator or bystanders.

Operation Warnings

- Do not at any time carry passengers, sit or stand on the log splitter.
- Do not allow children to play on, stand upon or climb on the log splitter.
- Always inspect the log splitter before using to assure it is in good working condition.
- Replace or repair damaged or worn parts immediately.
- Always check and tighten hardware and assembled parts before operation.
- Do not exceed equipment maximum load capacity of 22 tons.
- Avoid large holes and ditches when towing the equipment.
- Always operate the log splitter on clear and level ground.
- Do not operate the log splitter at night, only during daylight hours.
- Always tow at reduce speed in rough terrain, along creeks, ditches and on hillsides.
- To avoid personal injury and/or equipment damage **DO NOT EXCEED 45 MPH.**
- Always refer to the vehicle owner's manual for proper towing.
- Always secure and lock the log splitter to the vehicle hitch before towing.

Crush and Cut Hazards

- Always keep hands and feet clear from moving parts while operating the equipment.
- Always clear and keep work area clean and free of debris when operating.
- Always wear safety gear, eye protection, gloves and work boots when operating the log splitter.





WARNING

The warnings, cautions, and instructions outlined in this instruction manual cannot cover all possible conditions or situations that may occur. It must be understood by the operator that common sense and caution are factors which cannot be built into this product and must be supplied by the operator.

Assembly Is Required

This product requires assembly before use. See "Assembly" section for instructions. Because of the weight and/or size of the log splitter, it is recommended that another adult be present to assist with the assembly. **INSPECT ALL COMPONENTS** closely upon receipt to make sure no components are missing or damaged.

Hazard Signal Word Definitions

	<p>This is the safety alert symbol. It is used to alert you to potential personal injury hazards. Obey all safety messages that follow this symbol to avoid possible injury or death.</p>
	<p>DANGER indicates an imminently hazardous situation which, if not avoided, will result in death or serious injury.</p>
	<p>WARNING indicates a potentially hazardous situation which, if not avoided, could result in death or serious injury.</p>
	<p>CAUTION indicates a potentially hazardous situation which, if not avoided, may result in minor or moderate injury.</p>
	<p>CAUTION used without the safety alert symbol indicates a potentially hazardous situation which, if not avoided, may result in property damage.</p>

ABOUT YOUR 22 TON LOG SPLITTER

This hydraulic log splitter has a heavy-duty steel construction and 22 tons of ram force. When there's work to be done, you need outdoor power equipment you can rely on, this log splitter will get the job done fast. It is designed to work in vertical position only. It is easy to tow, easy to use and maintain. Never exceed the rated capacity of 22 tons when operating the log splitter.

Technical specifications on the log splitter are provided in the "Specifications" section of this manual.

Controls and Features Identification

Read this owner's manual before operating the equipment. Familiarize yourself with the location and function of the controls and features. Save this manual for future reference.

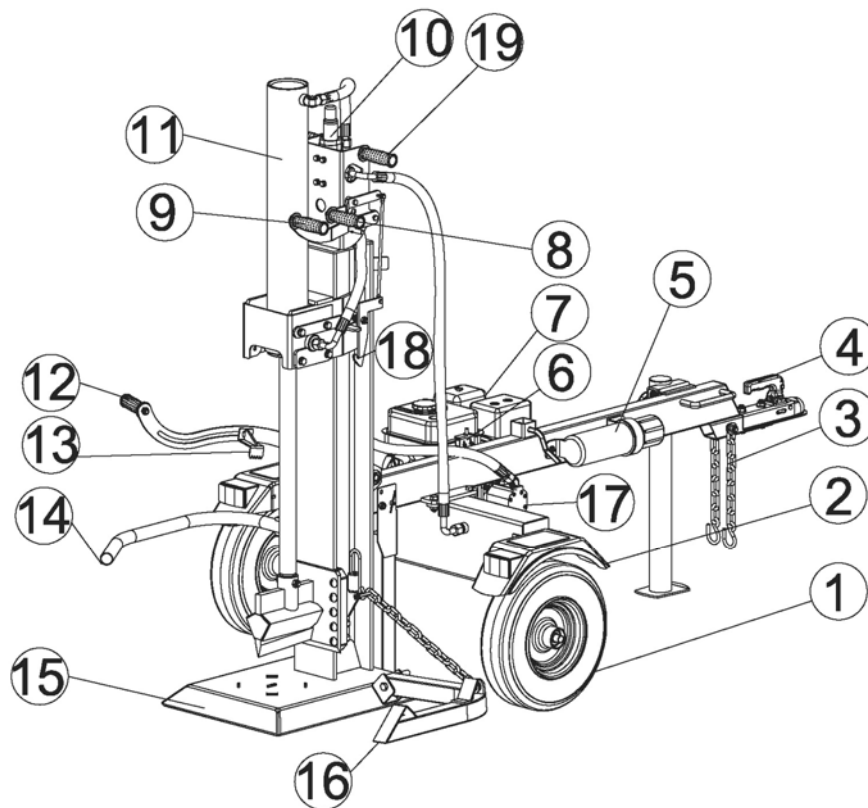

- 1) **Tire / Wheel Assembly** - Maximum rated towing speed is 45 MPH.
- 2) **Fenders**
- 3) **Safety Chains** - Safety feature to prevent loss of log splitter while towing.
- 4) **50mm Coupler** - Attaches the log splitter to the 50mm ball.
- 5) **Manual Canister** - Put the Instruction manual in this Canister.
- 6) **Switch** - Switch off the power supply of Engine when the beam is horizontal, so the log splitter can't be operated when horizontal.
- 7) **Engine** - Air cooled 208cc engine powers the hydraulic pump.
- 8) **Lifting Bracket Release Handle C** - Push down this handle can release the hook on the Chain of No.16 Lifting Bracket, then the No.16 Lifting Bracket can get down.
NOTE: Just needs to push down this handle shortly. Don't need to push it any more when the hook is released.
- 9) **Split Control Handle A** - push down it together with No.12 Split Control Handle B can down the Wedge to split the log, and push up this handle can lift the Wedge and No.16 Lifting Bracket together. NOTE: Push up this handle only can lift the Wedge if you haven't downed the No.16 Lifting Bracket.
- 10) **Control Valve** - Control operation.
- 11) **Cylinder** - 4" bore and 23-1/4" stroke, rated to 3600 psi.
- 12) **Split Control Handle B** - Push down it together with No.9 Split Control Handle A can down the Wedge to split the log.

- 13) **Log Fixture** - Fix it on the log to avoid the log creep down when user is splitting the log.
- 14) **Log Cradle**
- 15) **Beam**
- 16) **Lifting Bracket** - Lift log.
- 17) **Gear Pump**
- 18) **Hook**
- 19) **Rotate Handle** - Hold it when turn over the beam.



CAUTION

Read and follow all instructions for assembly and operation. Failure to properly assemble this equipment could result in serious injury to the user or bystanders, or cause equipment damage.



Engine Shipped Without Oil.

Before starting engine, fill with SAE 10W-30 motor oil. See engine manual for engine oil capacity.

Hydraulic Reservoir is Shipped Without Oil.

When adding oil verify the oil level using the Oil filter/Dip Stick on the top of hydraulic reservoir if marking is not shown fill to the L line.

Inspect all Log Splitter Components.

If you have damaged components: Contact the freight company that delivered the log splitter and file a claim.

22 TON LOG SPLITTER ASSEMBLY

Set the shipping crate on a solid flat surface and carefully remove the lid. Use two people and take all parts out of the shipping crate and inspect the components to ensure there are no missing pieces before starting to assemble the log splitter follow steps 1 through 9.

TOOLS REQUIRED

- Rubber or Wooden Hammer
- 13mm, 16mm, 17mm, 18mm, 19mm, 24mm, 27mm Wrenches
- Large Adjustable Wrench
- Phillips Screwdriver
- Pliers

Assembly Instructions

STEP 1: Wheel Assembly

1. Attach the wheels (#4) to the wheel stand secure using flat washer $\text{\O}20$ (#6), thin hex slotted nut M20x1.5 (#8) and cotter pin $\text{\O}4$ x36 (#5). Install the axle cap (#7) on the end using rubber hammer.

NOTE: Use a black plastic bushing to fix the axle cap (#7) like below picture. Please cover the black bushing onto the axle cap, and use rubber/wooden hammer knocking the end of the plastic bushing and make the axle cap fixed on wheel.

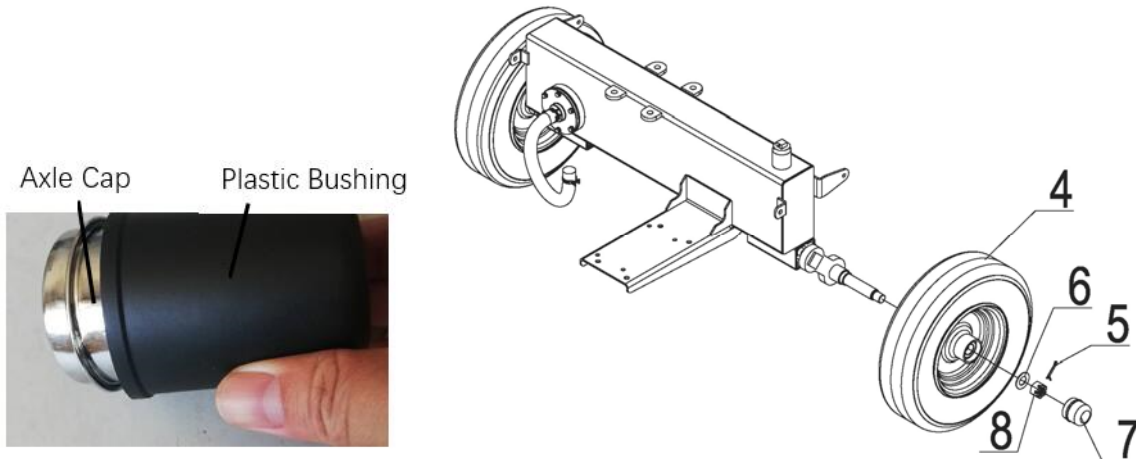

STEP 2: Attach Tow Bar and Fender

1. Attach the tow bar (#2) to the hydraulic reservoir using hex bolt M12x35 (#35), flat washer $\text{\O}12$ (#20) and hex lock nut M12 (#25).

2. Attach fenders (#89 & #90) to the hydraulic reservoir using hex bolt M8x25 (#69), flat washer $\text{\O}8$ (#37), lock washer $\text{\O}8$ (#57) and hex lock nut M8 (#38). Attach rubber washer (#131) between fender and hydraulic reservoir.

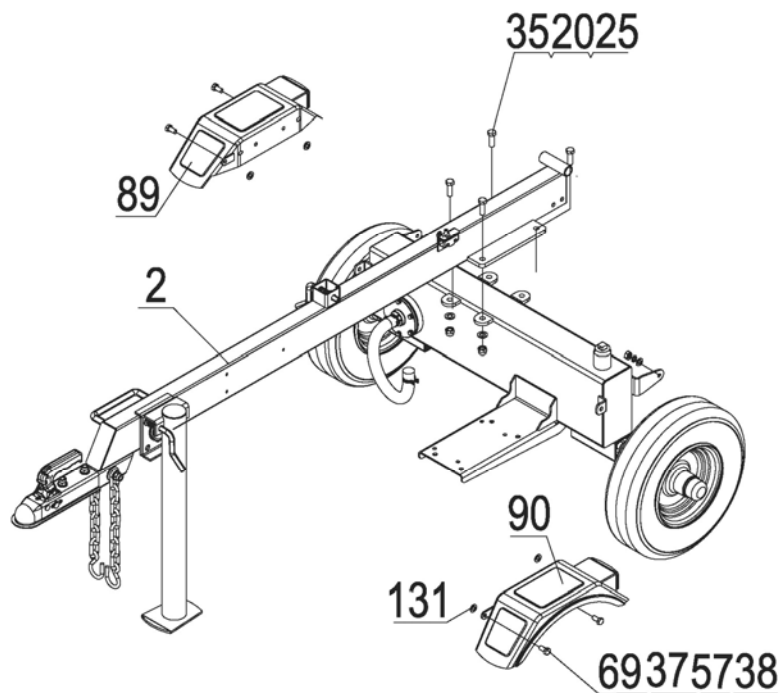

STEP 3: Attach Beam and Manual Canister

1. Attach the beam to the tow bar using Hitch Pin (#50) and R Pin (#71).
2. Attach rear support leg (#85) to the tow bar using hex bolt M10x70(#137) and hex lock nut M10 (#114). When standing, secure the beam with a pull handle (#82) and an R pin (#71).
3. Remove hex bolt M6x65 (#104), large flat washer $\varnothing 6$ (#105) and nylon lock nut M6 (#102) from tow bar, secure manual canister (#101) to the tow bar by items #104, #105 and #102.
4. Attach three plastic handles (#14) to the control handle and two plastic handles (#14) to the beam control valve mounting plate by hex lock nut M10 (#114).

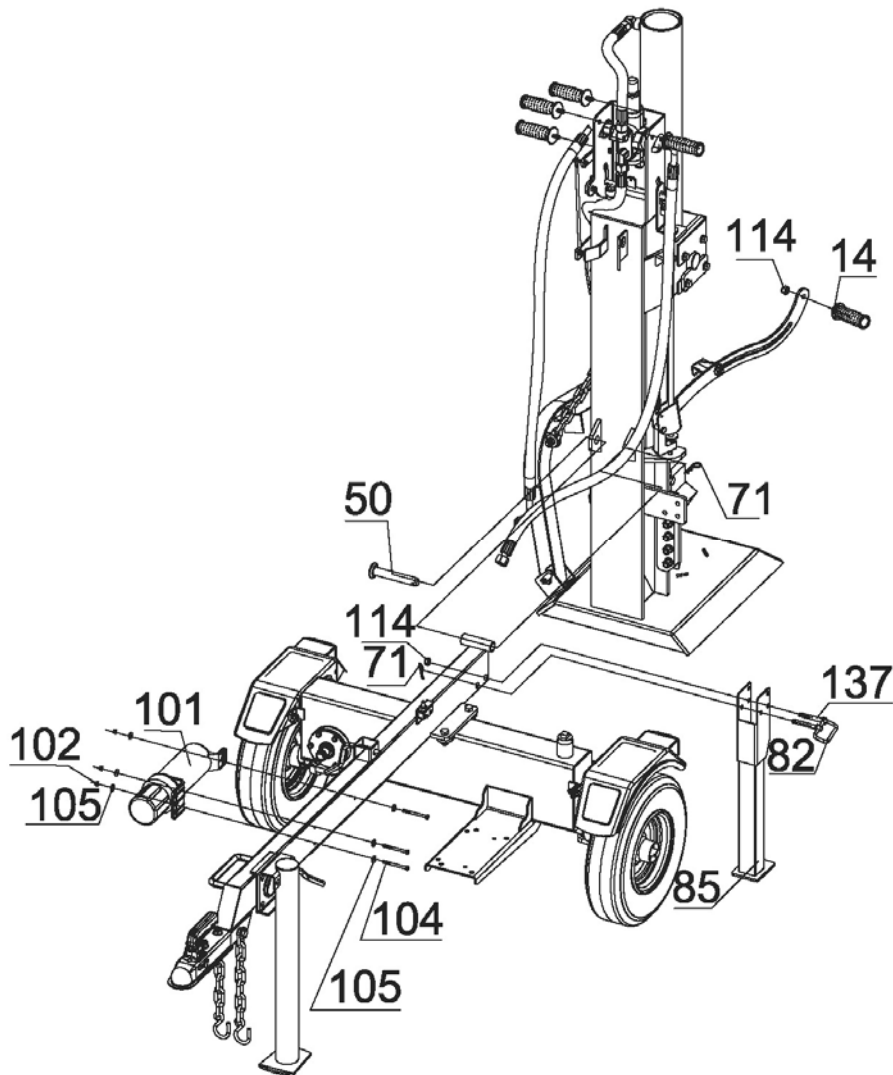

STEP 4: Attach Engine and the Oil Pipe

1. Attach the engine (#11) to the wheel stand using polyurethane block (#12) and large flat washer $\varnothing 10$ (#58), hex bolt M8x65 (#36), flat washer $\varnothing 8$ (#37), lock washer $\varnothing 8$ (#57), hex lock nut M8 (#38).
2. Attach the clear oil pipe (#43) to the gear pump oil inlet connector, positioning by clamp (#44).
3. Attach the high pressure oil pipe (#39) to the gear pump oil outlet connector, sealing with O ring $\varnothing 11.2 \times 2.4$ (#32).
4. Attach hydraulic hose (#42) to hydraulic reservoir connector, sealing with O ring $\varnothing 11.2 \times 2.4$ (#32).

Note: Tighten hydraulic hose connector between torque of 80-90N · m. Adjust the hydraulic hose to a non-kinked state and the connector should be upright.

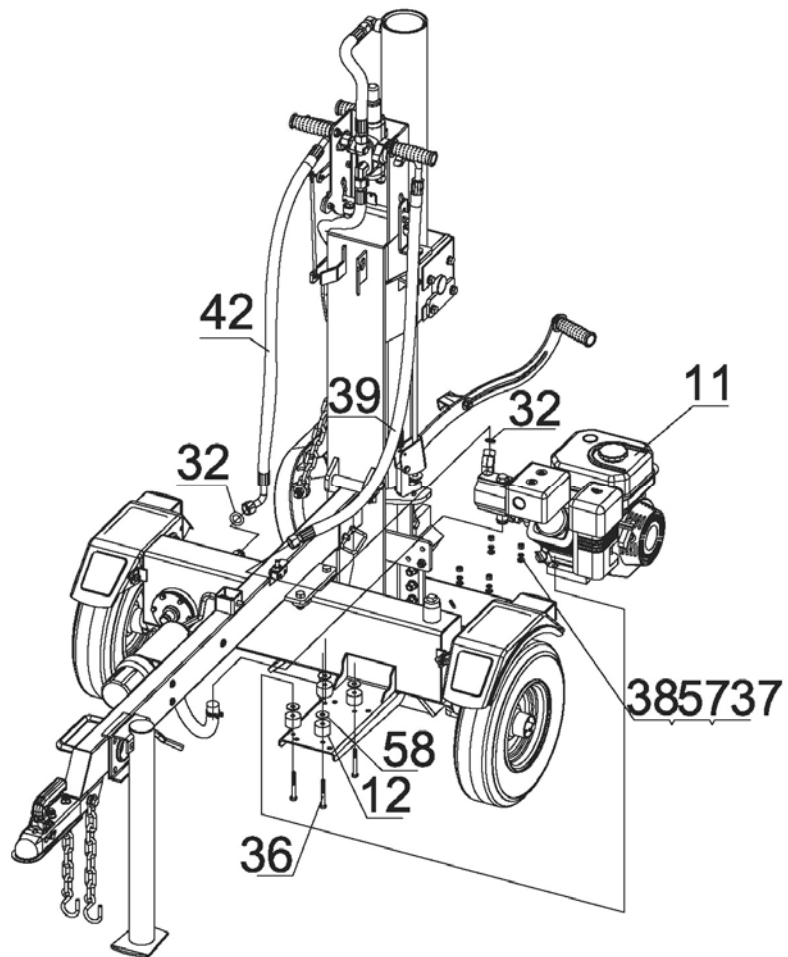

STEP 5: Electric Breaking Switch

1. Connect the wires of engine and electric breaking switch using quick connector.

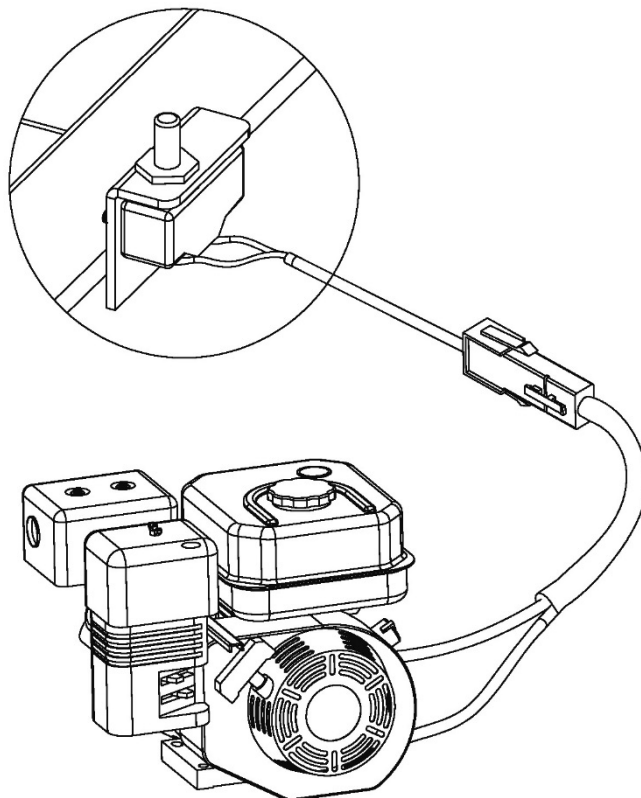

STEP 6: Attach the Log Cradle

1. Attach log cradle (#53) to the beam using hex bolt M10x35 (#129) and hex lock nut M10 (#114). The tightness is appropriate for log cradle rotation.

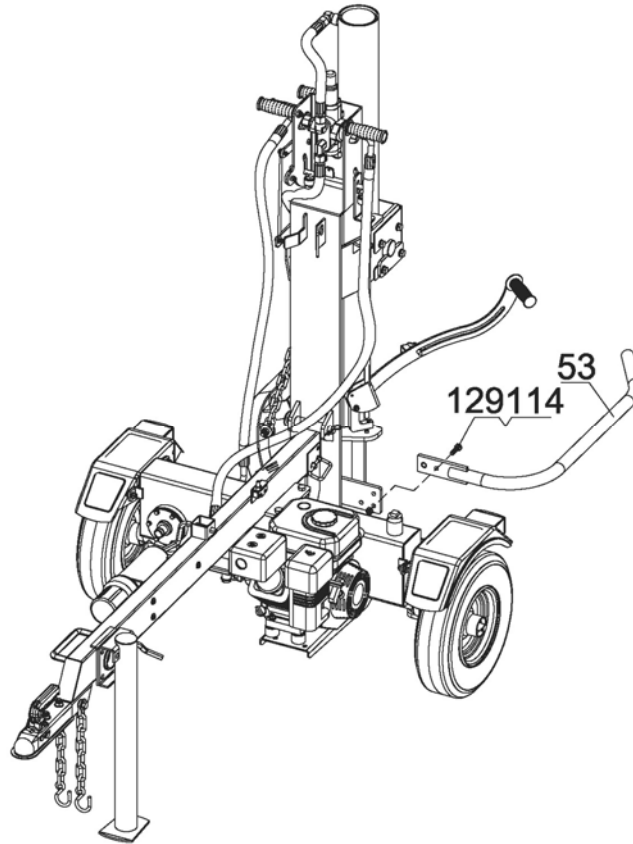

STEP 7: Add Engine Oil

1. Make sure the log splitter is on a level surface.
2. Remove oil fill cap/dipstick to add oil.
3. Refer to the separate owner's engine manual for the amount needed of SAE10W-30 engine oil; replace oil fill cap/dipstick.
4. Check engine oil level daily and add as needed.

NOTE: During the break-in period check the engine oil level often.



CAUTION

DO NOT attempt to crank or start the engine before it has been properly filled with the recommended type and amount of oil. Damage to the log splitter as a result of failure to follow these instructions will void your warranty.

STEP 8: Add Gasoline to the Engine

1. Use only clean, fresh, regular unleaded fuel with a minimum 86 octane rating.
2. DO NOT mix oil with fuel.
3. Remove the fuel cap and slowly add fuel to the tank. DO NOT overfill allow approximately $\frac{1}{4}$ inch of space for fuel expansion.
4. Screw on the fuel cap and wipe away any spilled fuel.

 **DANGER**

Log splitter engine exhaust contains carbon monoxide, a colorless, odorless, poison gas. Breathing carbon monoxide will cause nausea, dizziness, fainting or death. If you start to feel dizzy or weak, get to fresh air immediately.

Operate log splitter outdoors only in a well ventilated area.

DO NOT operate the log splitter inside any building, enclosure or compartment.

DO NOT allow exhaust fumes to enter a confined area through windows, doors, vents or other openings.

DANGER CARBON MONOXIDE, using a log splitter indoors **CAN KILL YOU IN MINUTES**.

 **CAUTION**

Fuel and fuel vapors are highly flammable and extremely explosive.

Fire or explosion can cause severe burns or death.

Unintentional startup can result in entanglement, traumatic amputation or laceration.

Only use regular unleaded gasoline with a minimum 86 octane rating.

DO NOT mix oil and gasoline together.

Fill tank approximately ¼" below the top of the tank to allow for fuel expansion.

DO NOT fill fuel tank indoors or when the engine is running or hot.

DO NOT light cigarettes or smoke when filling the fuel tank.

STEP 9: Add Hydraulic Oil

1. The log splitter needs to be on a flat, level surface before adding the hydraulic oil.
2. Remove the oil cap from the hydraulic reservoir.
3. Add 3 gallons of hydraulic oil AW32, AW46 & universal hydraulic oil are all acceptable types of fluid. **Automatic transmission fluid should be used when operating in temperatures below 32 degrees** (all units are tested and have excess oil in the ram).
4. Check the hydraulic oil level.
5. Start engine and use the control lever to extend and retract wedge several times to remove air from the lines.
6. With the wedge retracted, check hydraulic oil level again and fill if necessary.

 **WARNING**

DO NOT remove the hydraulic oil fill cap when the engine is running or hot. Hot oil can escape causing severe burns. Always allow the log splitter to cool completely before removing the hydraulic oil cap.

High fluid pressure and temperatures are created in the hydraulic log splitters. Hydraulic fluid will escape through a pin-size hole opening and can puncture skin and cause severe blood poisoning.

Inspect hydraulic system regularly for possible leaks. **Never check for leaks with your hand while the system is pressurized. Seek medical attention immediately if injured by escaping fluid.**

Make sure all fittings are tight and secure before applying pressure. Relieve system pressure before servicing.

Make sure the hydraulic hoses do not touch any hot surfaces or cutting areas.

Hoses need to be positioned where they are clear from the engine and cutting wedge. To avoid serious bodily injury always inspect the hoses before operating the log splitter.

Operation Instructions

WARNING

Before operating or using the log splitter, review the instructions below and all safety information. Failure to follow these instructions may result in property damage or injury to the operator or bystanders.

USING YOUR LOG SPLITTER

STEP 1: Press split control handle A and split control handle B at the same time, and take the lifting bracket release handle C with slightly (it can be released after the lifting rack comes down). Do not touch the lifting control hand if you don't want to release the lifting rack.

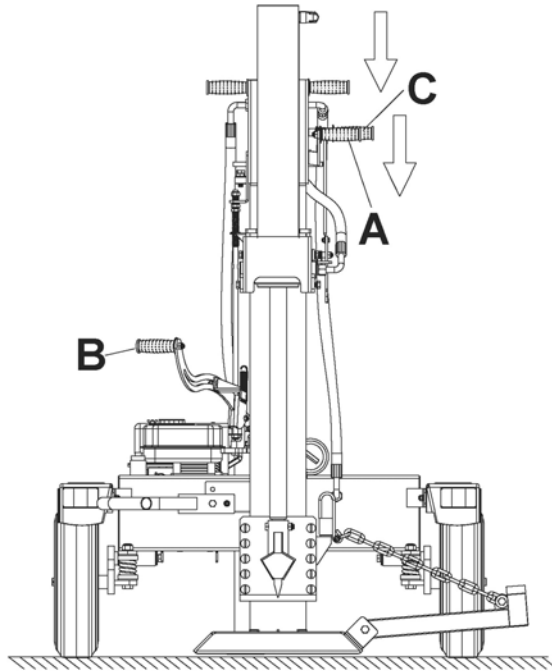

STEP 2: Put the wood on the lifting bracket, then push the split control handle A upward. The wood will be lifted slowly along with the cylinder.

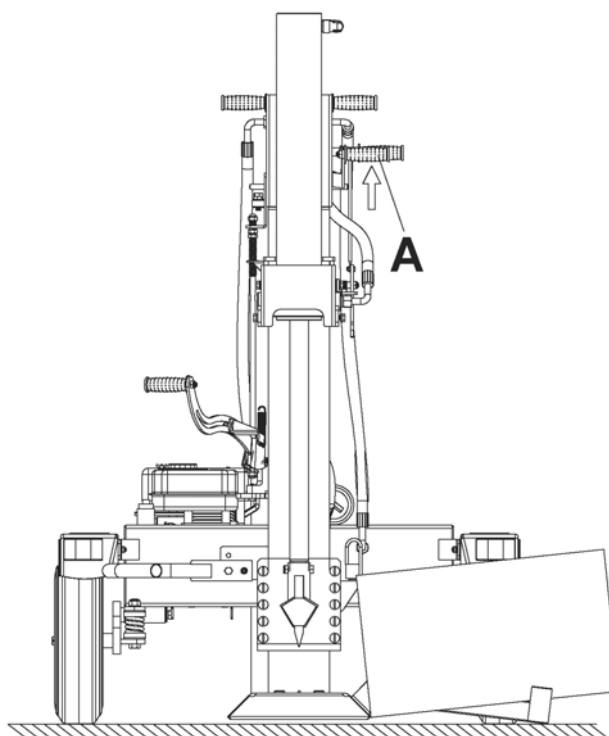

STEP 3: When the wood is lifted in place, place the wood in the center of the wedge, and press split control handle A and split control handle B to split wood.

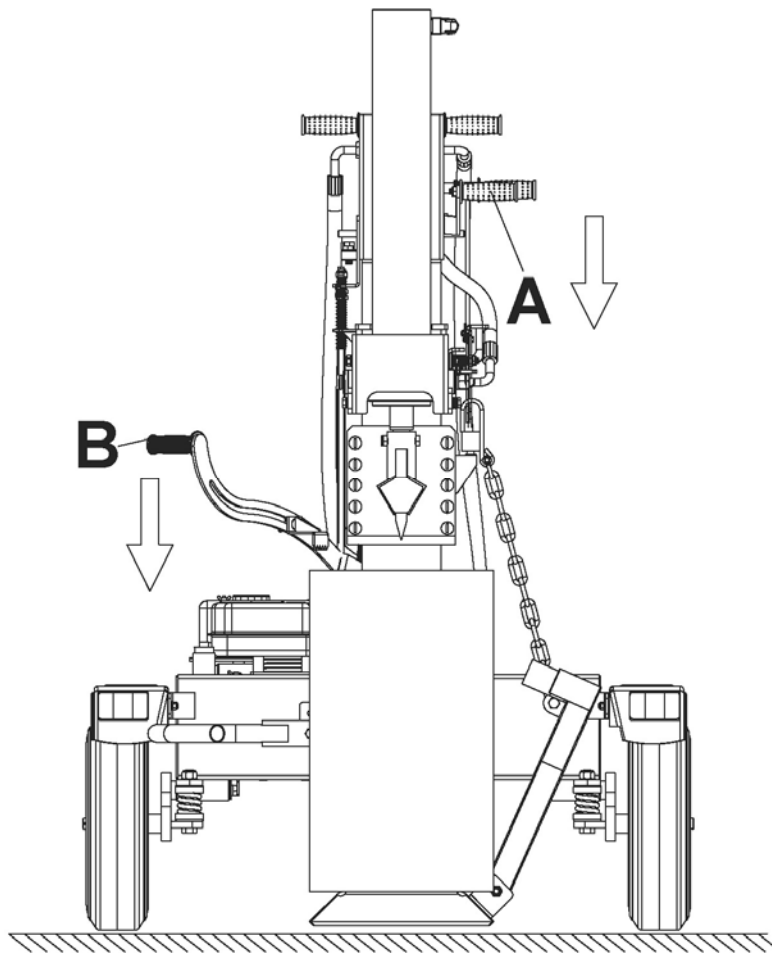

⚠ WARNING

ALWAYS use the log splitter for its intended use.
ONLY use the log splitter to split wood logs, length wise with the grain.
NEVER modify, alter or change the log splitter in anyway, modifications will void the warranty.
NEVER attach a rope, cable or other device to the control lever on the log splitter.
ONLY operate the log splitter in daylight.
NEVER leave the log splitter unattended while the engine is running.
DO NOT change the splitting position with the engine running. Contact with the muffler can cause serious burns.
ALWAYS make sure the beam is in the locked position.
DO NOT let the beam drop as it could crush fingers or cause damage to the log splitter.
NEVER operate or let anyone else operate, the log splitter while under the influence of alcohol, drugs, or medication.
DO NOT put feet in the range of wedge activity during the operating.
STOP engine if the wood catches the wedge and cannot be split or the wood follows the wedge up.
DO NOT close to the lifting bracket when movement.

1. DO NOT at any time carry passengers, sit or stand on the log splitter.
2. Check the hydraulic oil level and visually inspect all hoses and attachments for problems.
3. Inspect the engine and make sure the engine oil level is correct.

4. Before towing the log splitter the tires need to be fully inflated.

TIRE WARNING

DO NOT over inflate tires. Serious injury can result if tires explode
DO NOT tow the log splitter if the tires are worn or will not hold air.
DO NOT exceed the maximum 45 MPH towing speed.

5. Refer to the vehicle owner's manual for proper safety and towing instructions.

TOWING WARNING

Serious injury or death can occur if towing safety rules are not followed.
Always check the ball coupler and wheels to make sure all hardware is secure before towing.
Before towing a long distance check to make sure the axle nuts and pins are tight and securely in place.
Always use safety chains, secure and lock the log splitter to the vehicle hitch before moving.
Drive safely. Be aware of the added length of the log splitter.
Never exceed the maximum travel speed of 45 mph.
Never ride or transport cargo on the log splitter.
Turn off the vehicle before leaving the log splitter unattended.
Block the log splitter wheels to prevent unintended movement.

6. The log splitter must have at least seven feet of clearance from combustible material. It needs to be on a dry and level surface with good footing. Do not work on mud, ice, brush or snow. When using the log splitter the work zone must be maintained at all times.

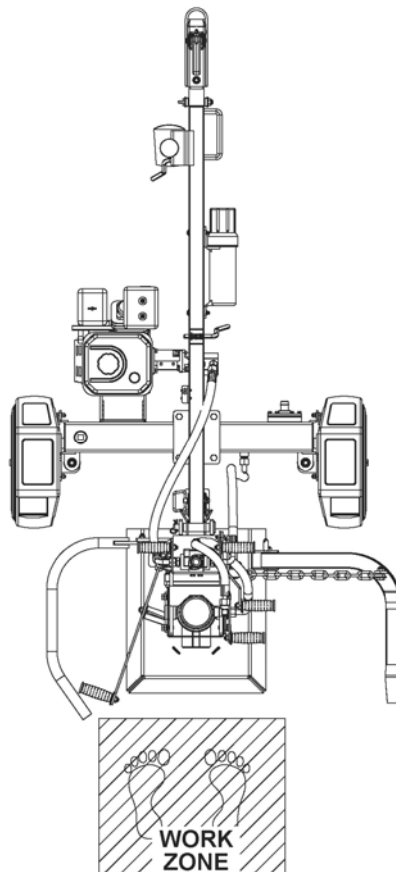

NOTE: Serious accidents can happen when other people are allowed inside the work zone. Keep everyone else outside the work zone while operating the control lever.

7. Always wear safety gear, eye protection, gloves and work boots when operating the log splitter
8. Start the engine and make sure the log splitter is on level ground before operating.

NOTE: The hydraulic oil needs to be above 10°F (-12C°) before starting the engine. Cold hydraulic oil can damage the hydraulic pump. If outdoor air temperature is below 32°F (0C°) allow the log splitter to warm up by extending and returning the wedge several times before splitting wood.

9. Put both support legs in the down position to prevent the log splitter from moving during operation and block both tires.
10. Load a log onto the beam against the endplate (Max Log Length-25")

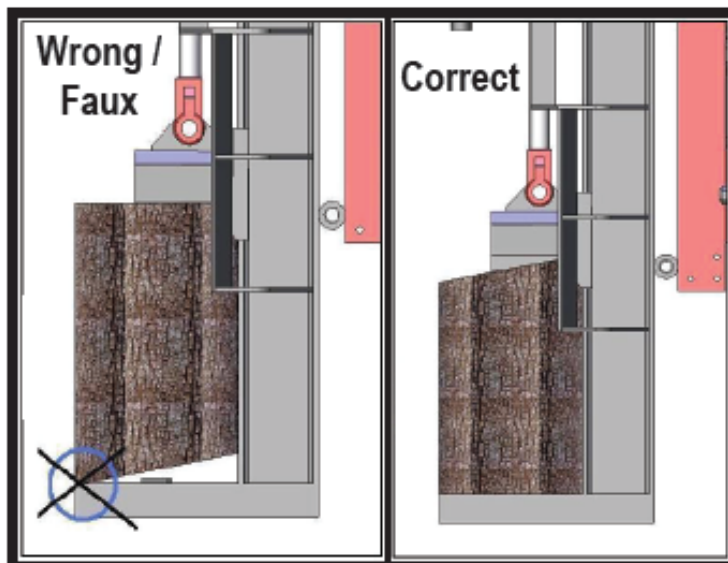

11. Make sure hands are clear from the wedge and crush hazard areas.

⚠ CRUSH WARNING

Wedge can cut through skin and break bones. Keep both hands away from wedge and beam slide. Serious accidents can happen when other people are allowed inside the work zone. Keep everyone else out of the work zone while operating control lever.

DO NOT wear loose clothing. It can get tangled in moving parts of log splitter. Only use the log splitter in daylight so you can see what you are doing.



CAUTION

If a log gets stuck, embedded or will not split completely, push the control lever in the reverse direction and allow the splitter to strip the log from the wedge.

If the log still remains stuck, embedded or will not split, turn the machine off and use a sledge hammer and crow bar to remove the log.

ALWAYS keep hands clear of the log and wedge while it is retracting.

12. Always keep work zone clean and free of split wood and debris.

FOR VEHICLE TOWING

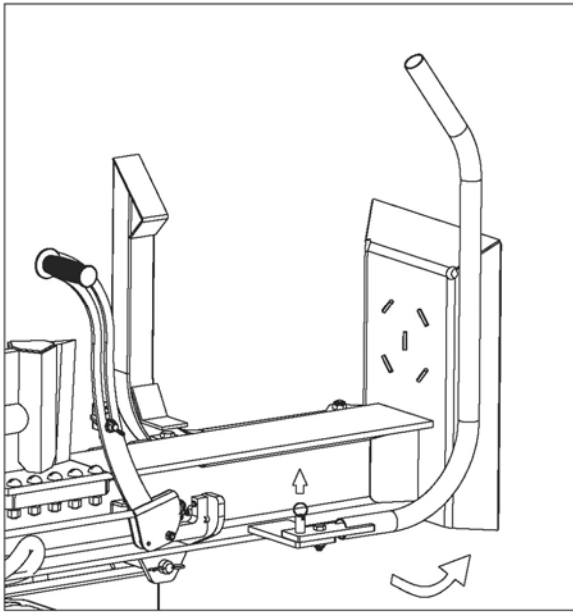

When vehicle towing, pull the log cradle back in the direction of the arrow, and stick the spring pin. Stick the spring pin when using.

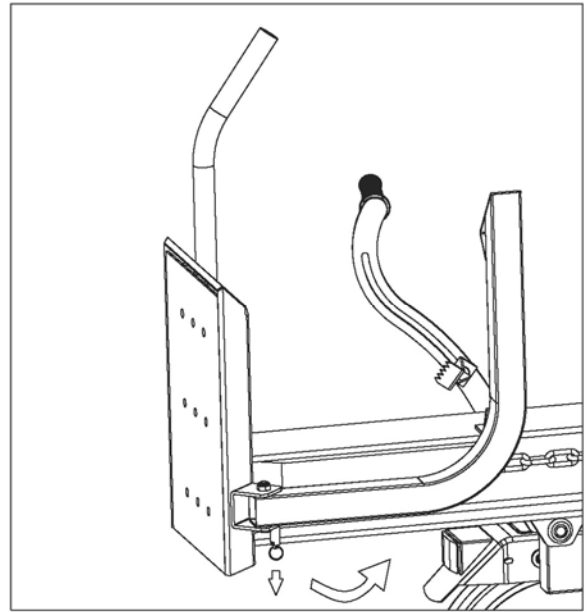

When vehicle towing, pull the lifting bracket back in the direction of the arrow, and stick the spring pin. Loose the spring pin when using. Just separate the lifting bracket from the pin hole.

NO HORIZONTAL USE

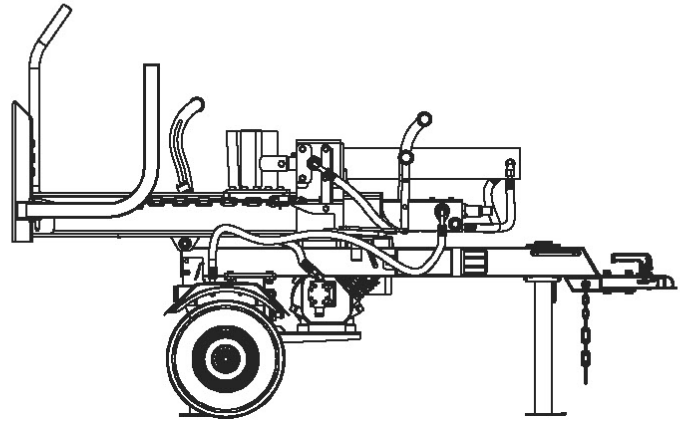

Note: Do not remove the Electric Breaking Swith without permission.

VERTICAL POSITION OPERATING ONLY

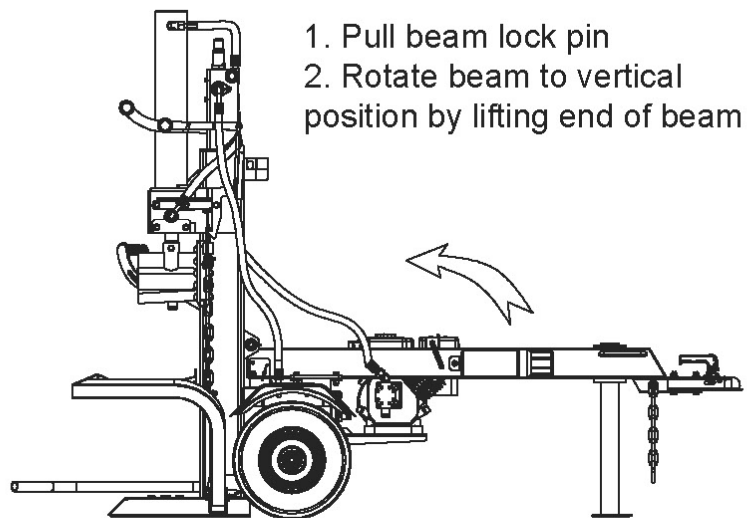

FOR VEHICLE TOWING

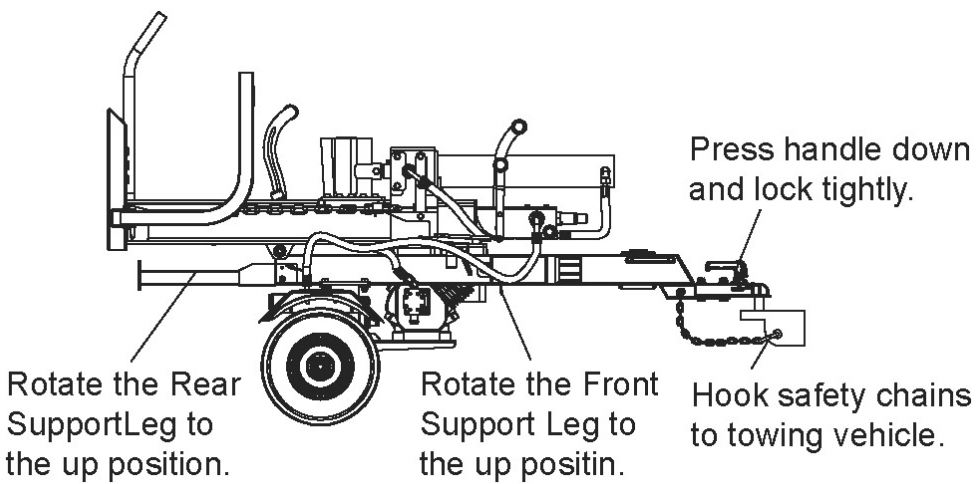

Maintenance and Storage



WARNING

Improper maintenance and storage of the log splitter may void your warranty.

MAINTENANCE

- Before performing maintenance, the log splitter must be placed in maintenance mode. Turn off the engine and move the control lever forward and backwards to relieve the hydraulic pressure.
- After performing any maintenance, make sure all guards, shields and safety features are put back in place before operating the log splitter.
- Before operating make sure the tires have the **RECOMMENDED TIRE PRESSURE**.
- Regularly grease axle and wheel bearing area or when needed.
- After the wheel bearings have been greased make sure the axle nuts and pins are in place and secure.
- Periodically check all fasteners and hoses for tightness and leaks.
- Annually clean and lightly lubricate all moving parts or when needed.
- Use a glossy enamel spray paint to touch up scratched or worn painted metal surfaces.
- Never exceed load capacity rating of 22 tons it will damage the log splitter.

What	When	How
Hoses	Each Use	Inspect hoses for exposed wire mesh and leaks. Replace all worn or damaged hoses before starting the engine.
Hydraulic Fittings	Each Use	Inspect fittings for cracks and leaks. Replace all damaged fittings before starting the engine.
Nuts and Bolts	Each Use	Check for loose bolts, tighten before operating.
Beam	Each Use	Apply grease to beam surface.
Moving Parts	Each Use	Clear debris from log splitter.

Refer to the Engine Owner's Manual for engine maintenance.

IMPORTANT:

If a part needs replacement, only use parts that meet the manufacturer's specifications. Replacement parts that do not meet specifications may result in a safety hazard or poor operations.

STORAGE

- Before storing make sure the log splitter is clean and dry for years of trouble free service.
- Lightly lubricate all log splitter surfaces and moving parts to prevent rust.
- Store indoors or protected area during severe weather and winter months.

Troubleshooting

Problem	
Cylinder rod will not move	SOLUTION: A,D,E,H,J
Slow cylinder rod speed when extending or retracting	SOLUTION: A,B,C,H,I,K,L
Wood will not split or splits extremely slowly	SOLUTION: A,B,C,F,I,K
Engine bogs down during splitting	SOLUTION: G,L
Engine stalls under low load condition	SOLUTION: D,E,L,M
Cause	Solution
A -Insufficient oil to pump	Check oil level in reservoir
B -Air in oil	Check oil level in reservoir
C -Excessive pump inlet vacuum	Check pump inlet hose for blockage or kinks
D -Blocked hydraulic lines	Flush and clean the splitter hydraulic system
E -Blocked control valve	Flush and clean the splitter hydraulic system
F -Low control valve setting	Adjust control valve with a pressure gauge
G -High control valve setting	Adjust control valve with a pressure gauge
H -Damaged control valve	Return control valve for authorized repair
I -Internal control valve leak	Return control valve for authorized repair
J -Internal cylinder leak	Return cylinder for authorized repair
K -Internally damaged cylinder	Return cylinder for authorized repair
L -Engine Control out of adjustment	Adjust idle control nuts
M -Engine is loaded during idle down mode	Use shorter log length (25" or less) to allow engine to speed up before contact.

Specifications

Max. Force	22Ton
Cycle Time.....	12.5s
Hydraulic Reservoir Capacity	14.5L
Max. Log Diameter & Length.....	13.7"x24"
Hydraulic Cylinder	4" x 23-1/4"
Max. Pressure	25Mpa (3600 psi)
Gear Pump	11GPM, 2-Stage
Max. Towing Speed	45 MPH
Wheel Size	16inches (4.8 x 8)
Engine	6.5HP, 3600RPM
Overall Size	228x114x122cm (89.8"x45"x48")

NOTE: For Engine Details Refer to the Engine Owner's Manual.

Parts Drawing & Parts List

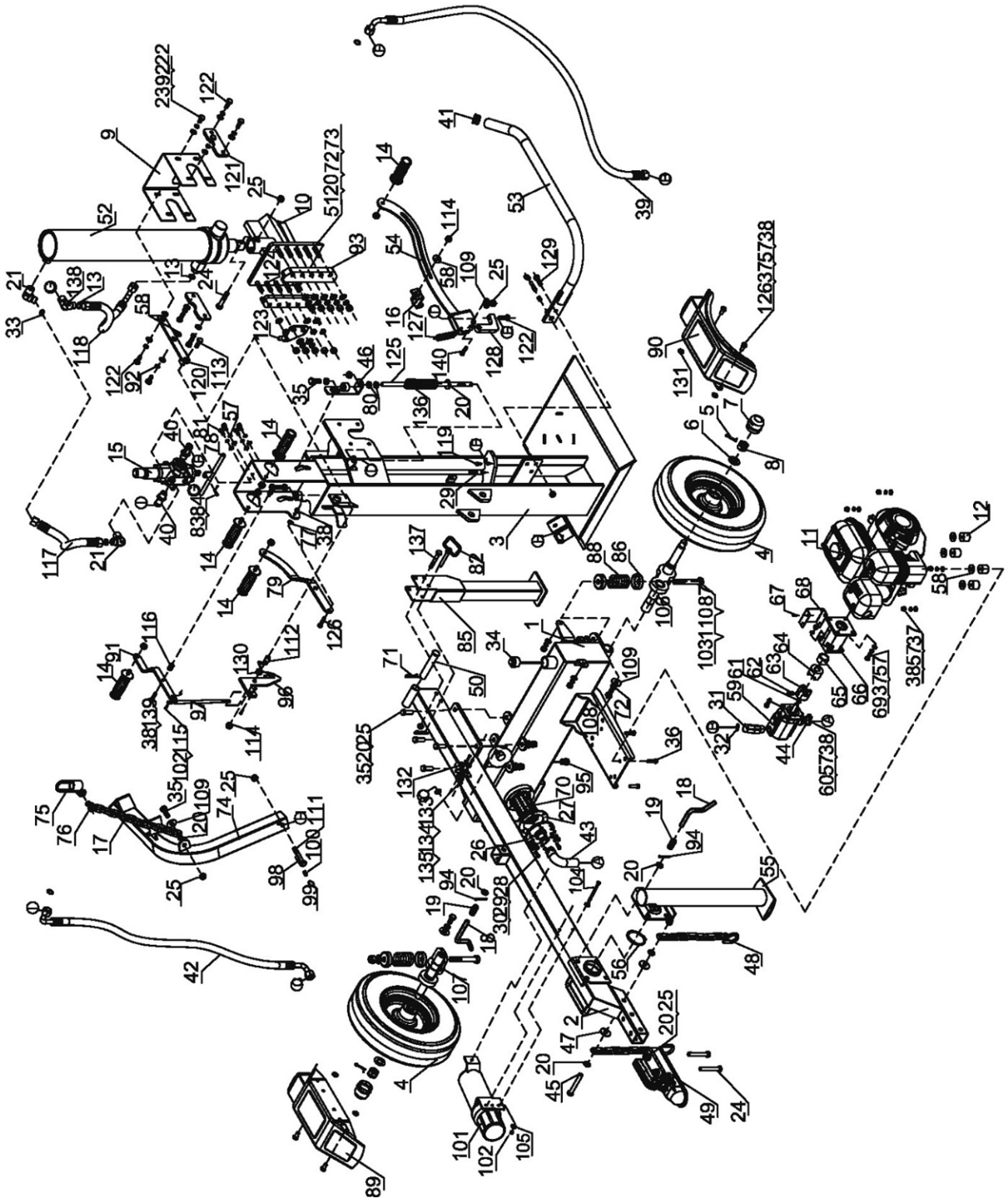

Parts Drawing & Parts List

Ref#	Drawing No.	Description	Qty
1	LSE2203-02000	Hydraulic Reservoir	1
2	LSE2203-03000	Tow Bar Assembly	1
3	LSE2203-01000	Beam	1
4	LSP25-14000	Wheel Assembly	2
5	9404-04036-DX	Cotter Pin Ø4x36	2
6	9301-20000-DX	Flat Washer Ø20	2
7	LSP25-00009-DX	Axle Cap	2
8	LSP25-00020-FH	Thin Hex Slotted Nut M20x1.5	2
9	LSM22A-00003	Cylinder Cover	1
10	LSE2203-04000	Wedge	1
11	LSP25-10001	Engine	1
12	LSP25-00025	Polyurethane Block	4
13	9901-16*2.5	O Ring Ø16x2.5	2
14	N600-00003	Plastic Handle	5
15	LSCA22-07001	Control Valve	1
16	LSE2203-06000	Presser Foot	1
17	LSE2203-00012-DX	Chain	1
18	LSP25-00008-DX	Safety Pin	2
19	LSP25-00003-DX	Spring	2
20	9301-12000-DX	Flat Washer Ø12	22
21	LSG22-00006-DX	Angle Connector	2
22	9301-10000-DX	Flat Washer Ø10	8
23	9101-10025-DX8.8	Hex Bolt M10x25	2
24	9101-12070-DX8.8	Hex Bolt M12x70	3
25	9206-12000-DX	Hex Lock Nut M12	12
26	LSP25-15000-DX	Filter Mounting Plate	1
27	LSP25-00021	Rubber Washer	1
28	9301-06000-DX	Flat Washer Ø6	6
29	9306-00006-DX	Lock Washer Ø6	6
30	9101-06020-DX8.8	Hex Bolt M6x20	6
31	LSE35-00002-DX	130° Joint Connector	1
32	9901-14×2.5	O Ring Ø14x2.5	4
33	9901-11×2.5	O Ring Ø11x2.5	2
34	LSP25-13000	Oil Bolt	1
35	9101-12035-DX8.8	Hex Bolt M12x35	7
36	9101-08065-DX8.8	Hex Bolt M8x65	4

Ref#	Drawing No.	Description	Qty
37	9101-08000-DX	Flat Washer Ø8	16
38	9206-08000-DX	Hex Lock Nut M8	15
39	LSE2203-00015	Hydraulic Hose (Valve-Gear Pump)	1
40	LSE22-00005	Extension Connector	2
41	LSE22-00011	Plastic Plug	1
42	LSE2203-00016	Hydraulic Hose(Valve-Hydraulic Reservoir)	1
43	LSE22-00014	Clear Oil Pipe	1
44	LSP25-00011	Clamp	2
45	9101-12090-DX8.8	Hex Bolt M12x90	1
46	LSE2203-11000	Pressure Link Plate	1
47	LSP25-00015-DX	Thick Washer	2
48	LSP25-11000-DX	Chain	2
49	Z104	50mm Coupler	1
50	LSP25-05000-DX	Hitch Pin	1
51	919904-12055-DX12.9	Slotted Head Screw M12x55	8
52	LSE2203-12000	Cylinder	1
53	LSE2203-10000	Log Cradle	1
54	LSE2203-07000	Split Control Handle B	1
55	LSE22-05000	Front Support Leg	1
56	9304-62000-FH	Circlip for Shaft Ø62	1
57	9206-08000-DX	Lock Washer Ø8	20
58	9302-10000-DX	Large Flat Washer Ø10	9
59	LSP25-10007	Gear Pump	1
60	9101-08030-DX8.8	Hex Bolt M8x30	4
61	LSP25-10008-FH	Steel Wire Snap Ring for Shaft	1
62	9121-06010-FH	Inner Hex Eng Set Screw M6x10	1
63	LSP25-10003	Gear Pump Coupler	1
64	LSP25-10002	Engine Coupler	1
65	LSP25-10004-DX	Engine Bushing	1
66	LSP25-10005	Gear Pump Stand	1
67	9101-05010-DX8.8	Hex Bolt M5x10	4
68	LSP25-10006	Coupler Cover	1
69	9101-08025-DX8.8Q	Hex Bolt M8x25	4
70	LSP25-00022	Filter	1
71	LSP25-00012-DX	R Pin	2
72	9306-12000-DX	Lock Washer Ø12	12

Ref#	Drawing No.	Description	Qty
73	9210-12000-DX8.8	Thick Nut M12	10
74	LSE2203-05000	Lifting Bracket	1
75	LSE2203-08000	Hook	1
76	DY1/4	Bow Shackle 1/4"	1
77	C130-00004	Nylon Pad	1
78	LSCA22-07100	Connecting Pipe	1
79	LSE2203-00007	Split Control Handle A	1
80	9201-12000-DX	Hex Nut M12	4
81	9105-08016-DX8.8	Hex Screw M8x16	4
82	LSA22-16000-DX	Hex Nut M8	1
83	9403-05026-DX	Hinge Pin	1
84	9404-2X10/DX	Cotter Pin Ø2x10	1
85	LSE2203-13000	Rear Support Leg	1
86	LSE22-00015	Spring Seat	4
87	9101-16110-DX8.8	Hex Bolt M16x110	2
88	LSE22-00016	Pressure Spring	2
89	LSP30-05000	Left Fender	1
90	LSP30-06000	Right Fender	1
91	LSE2203-00006	Lifting Bracket Release Handle C	1
92	9306-10000-DX	Lock Washer Ø10	8
93	LSA22-03001	Wedge Slide	2
94	9404-03030-DX	Cotter Pin Ø3x30	2
95	LSP25-00010-DX	Oil Plug	1
96	LSE2203-00004	Hook	1
97	LSE2203-00005	Connecting Rod	1
98	Z330-00008-DX	Pawl (B)	2
99	Z330-00017-DX	Key Ring	2
100	Z330-00003-FH	Spring B	2
101	LSP30MD-02000	Manual Canister	1
102	9206-06000-DX	Nylon Lock Nut M6	5
103	9206-16000-DX	Nylon Lock Nut M16	2
104	9101-06065-DX8.8	Hex Bolt M6x65	3
105	9302-06000-DX	Large Flat Washer Ø6	6
106	LSE22-11000	Left Axle	1
107	LSE22-09000	Right Axle	1
108	9101-12025-DX8.8Q	Hex Bolt M12X25	2
109	9302-12000-DX	Large Flat Washer Ø12	4

Ref#	Drawing No.	Description	Qty
110	9101-16000-DX	Flat Washer Ø16	2
111	9101-12075-DX8.8	Hex Bolt M12x75	1
112	LSE2203-00008	Axle Sleeve	1
113	9101-10055-DX8.8	Hex Bolt M10x55	1
114	9206-10000-DX	Hex Lock Nut M10	9
115	9101-06016-DX8.8	Hex Bolt M6x16	2
116	LSE2203-00011	Bushing	1
117	LSE2203-00014	High Pressure Hose B	1
118	LSE2203-00013	High Pressure Hose A	1
119	9105-06012-FH	Hex Socket Head Screw M6x12	2
120	LSE2203-00003	Connecting Rod A	1
121	LSE2203-00009	Cylinder Limit Block	2
122	9101-10030-DX8.8	Hex Bolt M10x30	7
123	LSE2203-09000	Chain Hoist	1
124	919904-12060-DX12.9	Slotted Head Screw M12x60	2
125	LSE2203-00010	Threaded Rod	1
126	9101-08025-DX8.8	Hex Bolt M8x25	5
127	LSF3000-00013	Tension Spring	1
128	LSE2203-00001	Rotating Seat	1
129	9101-10035-DX8.8	Hex Bolt M10x35	1
130	LSE2203-00002	Torsional Spring	1
131	LSA22-00021	Rubber Washer 2	4
132	LSE2203-14000	Electric Breaking Switch	1
133	9110-04030-DX8.8	Screw M4x30	2
134	9101-04000-DX	Flat Washer Ø4	4
135	9206-04000-DX	Hex Lock Nut M4	2
136	LSE2203-00018-DX	Pressure Spring	1
137	9101-10070-DX8.8	Hex Bolt M10x70	1
138	LSE2203-00017-DX	Angle Connector	1
139	9101-08040-DX8.8	Hex Bolt M8x40	1
140	9101-08035-DX8.8	Hex Bolt M8x35	1



EC Declaration of conformity

**Jiashan Superpower Tools Co., Ltd.
No.391, Huimin Road, Huimin Town, Jiashan County, Zhejiang, P. R.
China**

**Tel: 86-573-84647361
86-573-84647361**

Fax:

**Product Name:
Vertical Log Splitter**

**Model(s):
LSE2203, LSL2001**

We here declare that the products described above are in conformity with the following Directive(s):

2006/42/EC Machinery Directive

Moreover the following harmonized standards have been applied to the Model(s) above:

**EN ISO 12100:2010, EN 609-1:2017, EN 349:1993+A1:2008,
EN ISO 14120:2015, EN ISO 13857:2008**

The technical construction files required to demonstrate that the product(s) meet(s) the requirement(s) of the aforementioned directive(s) has been compiled.

**Issue
Manufacturer stamp and Signature of authorized personnel**

place:

JIASHAN, ZHEJIANG

