

Bike-Lift EUROPE

EC Use and Maintenance Manual

Scissor lifting platform		
Garden 1000		
	Model	Version
<input type="checkbox"/>	G-003/10	ELECTRO-HYDRAULIC PUMP
<input type="checkbox"/>	G-004/10R	ELECTRONIC WITH REMOTE CONTROL



Bike-Lift EUROPE s.r.l.

via Don Milani, 40/42





43012 Sanguinaro di Fontanellato (PARMA) – Italy

Website: www.bikelifteurope.it

E-mail: info@bikelifteurope.it

Summary

1	 Information section	4
1.1	Preface	4
1.2	Prohibitions.....	5
1.3	Warranty.....	5
1.3.1	Warranty conditions	5
1.3.2	Insurance	5
1.4	Manufacturer identification	6
1.5	Technical assistance and spare parts	6
1.6	EC Declaration of conformity	7
1.7	Normative references.....	8
1.8	Key	9
2	 Machine description	10
2.1	Machine name	10
2.2	Machine identification.....	10
2.3	Machine description	11
2.4	Intended use	12
2.5	Technical specifications	13
2.5.1	GARDEN 1000	13
3	 Safety section	14
3.1	Environmental working values	14
3.2	Sound level	14
3.3	Residual risks	14
3.4	Operator protections.....	15
3.5	Safety systems	15
3.6	Pictograms	16
4	 Transport and handling.....	17
4.1	Transport, handling and storage	17
4.2	Packaging and transport.....	17
4.3	Unloading and handling.....	17
4.4	Receipt and check.....	18
4.5	Storage.....	18
5	 Installation section	19
5.1	Power.....	19
5.2	Putting into service.....	20

6		Dismantling/scraping section	21
6.1		Dismantling	21
6.2		Mechanical dismantling	21
6.3		Scraping	21
7		Operation section	22
7.1		Loading operations	22
7.2		Unloading operations	23
7.3		Lifting types	23
7.3.1		ELECTRO HYDRAULIC PUMP - element code - 003	23
7.3.2		ELECTRONIC WITH REMOTE CONTROL - element code 004/R 24	24
8		Maintenance section	25
8.1		Lubrication	25
8.2		Bleeding of the hydraulic circuit	25
8.3		Piston replacement	26
8.4		Cleaning	27
8.4.1		Initial cleaning	27
8.4.2		General cleaning of the machine	27
8.4.3		Cleaning of the work areas	28
8.5		Problems and remedies	28
8.5.1		ELECTRIC PUMP	29
9		Accessories	31
SPARE PARTS - TECHNICAL DRAWINGS			32
9.1		GARDEN 1000	32

1 Information section

1.1 Preface

The EC Use and Maintenance Manual is a document issued by Bike-Lift Europe s.r.l. as an integral part of the Machine.

The purpose of this publication is to provide the operator with efficient and safe instructions regarding the use and maintenance.



This manual must be read before starting any operation regarding the installation, use, maintenance and putting out of service of the machine; therefore it is necessary to be kept intact over time.

In order to properly store the Manual it is recommended to:

- Use the manual without deteriorating it;
- Do not remove, add, change or rewrite any part of the Manual; any modifications must be made only by Bike-Lift-Europe s.r.l.;
- Keep the Manual in areas protected against humidity in order not to compromise its durability over time;
- Deliver the Manual to any other user or subsequent owner of the Machine.



Workers in charge of using this machine must have all the necessary information and must receive proper training.

The manual and relative documentation are confidential by law with the prohibition of reproduction or transmission to third parties without receiving the explicit authorization of the manufacturer.

As a partial exception to the above mentioned, a copy of this Manual kept in the vicinity of the Machine is allowed for prompt reference, in case the original document is stored in a different place, in order to guarantee better keeping over time.

Drawings, data and specifications contained in this manual can be modified at any time by the company, without prior notice.

In case of significant changes of the machine due to the installation of new parts, Bike-Lift Europe s.r.l. will compile an updated Manual that will be sent to the Customer together with the purchased part.

1.2 Prohibitions

The installation, use, maintenance and putting out of service of the device with means, objects, actions and anything else not provided for in this manual is considered improper and therefore the manufacturer declines all responsibility for the consequences that may occur regarding people, animals and objects.



It is expressly FORBIDDEN the use of the Machine by Operators who do not know the regulation and procedures described in the Manual and by unauthorized people (hereinafter referred to as "non-operators").

It is also forbidden the use of the machine by children and the non-operators or children must not stand near the machine during all phases of the machine's life.

The putting out of service of the protection systems or anything else provided by the manufacturer to protect the operators is the sole responsibility of the Purchaser or the Machine's User.

Any mechanical, electrical or functional change of the Machine (not provided for in this Manual) regarding the control systems, the logic of controls, the circuits present and the safety systems is prohibited without the prior written authorization of the manufacturer.

1.3 Warranty

Bike-Lift Europe s.r.l. will not be held responsible for inconveniences, breakages, accidents, etc. due to lack of knowledge or failure to apply the procedures specified in this Manual. The same applies to the execution of modifications, changes or for the installation of accessories not previously authorized.

1.3.1 Warranty conditions

Bike-Lift-Europe s.r.l. guarantees its products for 12 months, except for the commercial components that are guaranteed by the manufacturers.

All worn parts are excluded from the warranty.

The warranty is limited to the replacement, ex-works Bike-Lift Europe s.r.l., of those parts that are recognized as defective by Bike-Lift Europe s.r.l. due to a material or manufacturing defect and do not include labor or travel expenses required for their replacement.

The recognition of the warranty is void if the anomaly is due to an inappropriate use of the product, if the installation was not carried out according to the provisions of the company or if non-genuine parts were installed.

It also becomes void if the product has been submitted to performances exceeding those indicated by Bike-Lift - Europe s.r.l.

1.3.2 Insurance

All Bike-Lift-Europe s.r.l. products are insured with an RCP policy with a price ceiling of € 3.000.000. Damages caused by negligence or tampering are excluded.

1.4 Manufacturer identification

Bike-Lift EUROPE s.r.l. via Don Milani, 40/42, 43012 Sanguinaro di Fontanellato (PARMA) – Italy



Website: www.bikelifteurope.it



E-mail:
info@bikelifteurope.it



Tel: 0039-0521-827091



Fax: 0039-0521-827064

1.5 Technical assistance and spare parts

To order spare parts, it is recommended to specify exactly the following data:

- Model and serial number of the machine;
- Code number and part name;
- Required quantity;
- Shipping means, address and telephone number;

For replacements use only genuine spare parts.

Do not wait until the components are completely worn before replacing them.



CAUTION: THE RECIPIENT WILL BE CHARGED FOR THE REPLACEMENT TOGETHER WITH THE SHIPPING COSTS.

We recommend that you always contact Bike-Lift Europe s.r.l. for all those Assistance and maintenance operations that are not described or indicated in this Manual.

1.6 EC Declaration of conformity

I	FR	GB	D	E	NL
Dichiarazione di conformità	Declaration de conformité	Declaration of conformity	Konformitäts- erklärung	Declaración de conformidad	Declaratie van conformiteit
Io sottoscritto	Je soussigné	The undersigned	Der Unterzeichnete im name der	El abajo firmante	Ondergetekende
Bike-Lift EUROPE s.r.l. via Don Milani, 40/42, 43012 Sanguinaro di Fontanellato (PARMA) – Italy					
Dichiara sotto la propria responsabilità, che il sollevatore	Déclare sous sa propre responsabilité que la table élévatrice	Declares under its own responsibility that the lifting platform	Erklärt auf eigene Verantwortung dass die Hebebühne	Declara bajo su responsabilidad que la mesa elevadora	Verklaart op eigen verantwoordelijkheid dat de te liften tafel
Marca	Marque	Trademark	Marke	Marca	Merk
Bike-Lift CE					
Modello:	Modèle:	Model:	Modell:	Modelo:	Model:
Numero di serie	Numéro de série	Serial number	Serien Nummer	Numero de serie	Seriennummer
Conforme alla direttiva	Est conforme aux spécifications de la directive	Complies with the requirements established by directive	Die Bestimmungen des Erlasses	Cumple los requisitos de la directiva	Overeenkomt met het gestelde in
MD 2006/42/EC LVD 2014/35/EC EMC 2014/30/EC					
E successive modifiche ed integrazioni, secondo le norme	et compris les modifications et les intégrations, selon la norme	And subsequent modifications and supplements, according to standard	Und den nachfolgenden Änderungen entspricht, entsprechend den Richtlinien	Y sucesivas modificaciones e integracions, según la norma	En aanvullingen en modificaties hiervan, volgens richtlijn
EN ISO 12100:2010; EN 349; UNI EN ISO 13850; EN 1493:2010; EN 60204-1; EN 982					
Bike Lift Europe srl					
Alessandro Tozzi					

1.7 Normative references

The machine is identified by the CE marking drawn up according to the specifications of the Machinery Directive 2006/42/EC and subsequent updates.







Reference	Title
2006/42/EC	Machinery Safety Directive
2014/30/EC	Electromagnetic Compatibility Directive (EMC)
2014/35/EU	Low Voltage Directive (LVD)
EN ISO 12100 (2010)	Safety of machinery - General principles of design - Risk assessment and risk reduction.
UNI EN 349 (1993+A1: 2008)	Safety of machinery - Minimum spaces to avoid the crushing of body parts.
UNI EN ISO 13850 (2008)	Safety of machinery - Emergency shutdown - Design principles
EN 1493 (2010)	European standard on vehicle lifting platforms
EN 60204-1 (2016)	Directive on the state of the art for the design and construction of the electrical equipment of machines, including the switchboard connected to the machines.
UNI EN ISO 4413:2012	Safety of machinery - Safety requirements related to systems and their components for hydraulic fluid and pneumatic transmissions - Hydraulic fluid
UNI 1285-68	Calculation of metal pipes resistance subject to internal pressure



1.8 Key

LIFTING PLATFORM: electric scissor lifting system for the maintenance and repair of motorcycles, scooters and quads. The specific identification of the lifting platform is indicated on the cover.

OPERATOR: In compliance with Directive 2006/42/EC and subsequent updates, it is specified that the term "operator" means the person (s) in charge of installing, operating, adjusting and cleaning the lifting platform. The maintenance and repair operations of the lifting platform are the responsibility of competent personnel.

SYMBOLS	MEANING
	Yellow triangle pictogram generally indicates a Warning /Risk, e.g. risk of high temperatures, risk of crushing the hands, ...
	BLUE round pictogram generally indicates an Obligation, for example the obligation to wear certain PPE (goggles ...) or the Obligation to read the User Manual.
	Round red Prohibition pictogram indicates in general a Prohibition, for example, person access prohibition, prohibition of hand access while the vehicle is moving.
	Indicates that the operation can be performed by specialized personnel authorized by the Employer.
	Particular importance indication that requires attention.
	Specifies an operation that can only be performed by trained personnel, or after having read and consulted specific operating instructions.

2 Machine description

2.1 Machine name

Scissor lifting platform for the maintenance and repair of motorcycles, scooters and quads with a maximum capacity of 1000 kg.

The handling of the Bike-Lift-Europe s.r.l. lifting platforms can be done through one of the following systems:

- electro-hydraulic system;
- electronic system with remote control

This manual refers to the model of lifting platform indicated on the cover

2.2 Machine identification



Figure 1 – Example of a plate affixed to the machine

The identification data of the machine are indicated on the plate placed on the structure and shown in the attached declaration of conformity.

Refer to these details for ordering spare parts and for any kind of contact with the manufacturer

It is absolutely forbidden for the user to remove or alter this plate. Any modification or removal of the plate will void any warranty.

The machines can be subject to updates or small aesthetic changes and therefore have different details than those shown, without prejudice to the descriptions and procedures contained by this Manual.

2.3 Machine description

The machine known as **Lifting Platform** is a suitable equipment to support small motor vehicles with 2, 3 or 4 wheels during the maintenance and repair phase in a comfortable and safe way.

The basic parts of the lifting platform (see Figure 2) are:

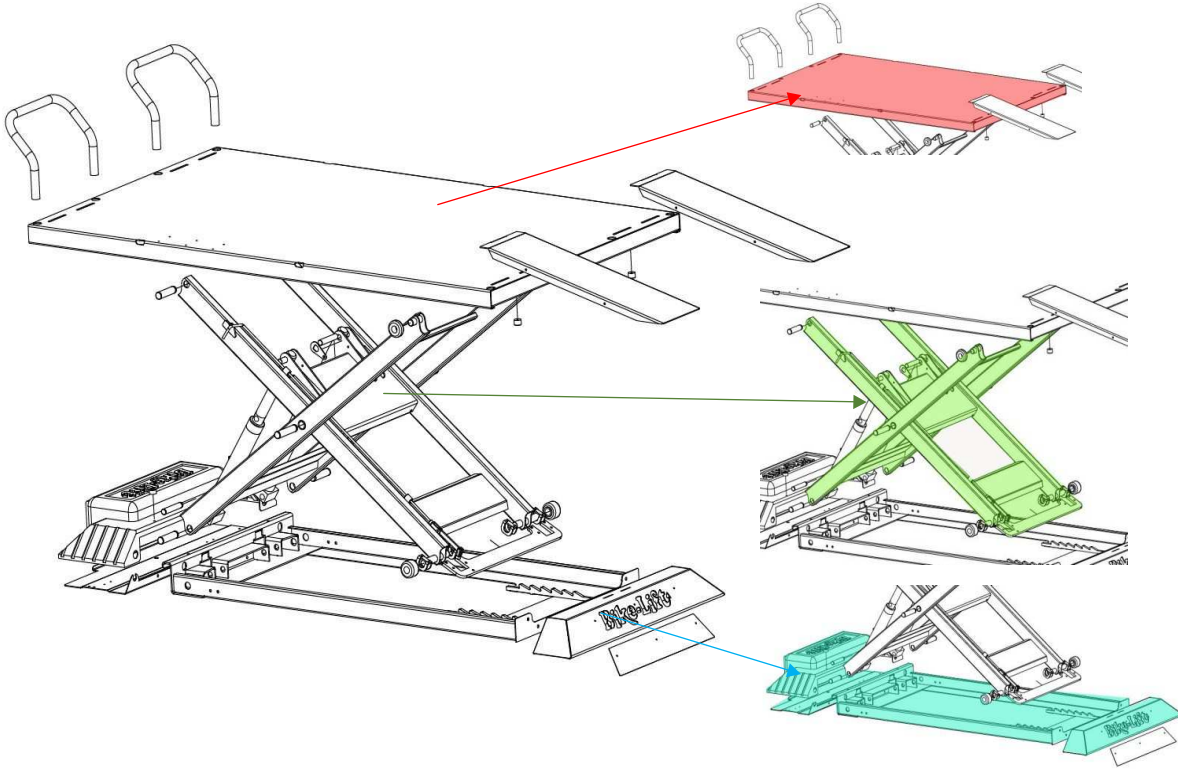
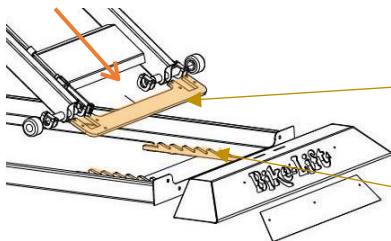

Figure 2 – Model of a lifting platform

- an elevating work platform (red);
- a base that can be anchored to the ground (blue);
- a scissor lift system consisting of two crossed X-shaped legs (green) handled by a hydraulic cylinder equipped with a parachute valve.

The fall protection system (shown in yellow in the following figure) consists of:



a mobile anchoring bar with automatic coupling that prevents the accidental descent of the mobile surface.

a mechanical safety system consisting of two toothed bars firmly welded to the base

2.4 Intended use



Disseminate the instructions described in this chapter to all personnel involved in the preparation and use of the machine.

The machine is designed to lift small motor vehicles with 2, 3 or 4 wheels, with a mass not exceeding 1000 kg, for maintenance purpose.



The machine has been designed and built for the specified use; a different use and non-compliance with the technical parameters set by the Manufacturer may be dangerous for the operators.

It can be used in the mechanical motorcycles repair shops both for the mechanical part and for the bodywork.



Any other use different from the one indicated is to be considered as not planned and may cause damage to the machine and Operators. It is therefore **FORBIDDEN**.



The machine must always be operated by only one Operator.

The Operator must always work in proper lighting conditions and wear clothes and protections appropriate to the task performed (typical activity of mechanical workshop)

The working position of the operator during the ascent and descent phases is in the area around the machine at the safety distance allowed by the cable length of the control panel.



It is absolutely forbidden to lift motorcycles while leaning on the side kickstand
Do not try to lift motor vehicles weighing more than the maximum capacity of the platform.

The machine was not designed for lifting people.

2.5 Technical specifications

2.5.1 GARDEN 1000

(see exploded diagram attached to this manual)

GARDEN 1000 VERTICAL SCISSOR LIFTING PLATFORM	
PARAMETER	VALUE
Maximum bearing	1000 kg
Maximum height	100 cm
Minimum height	19 cm
Safety positions number	6
Lifting surface size	215x120 cm
Ascent ramp size	82x24 cm
Total space of the lift	225x120 cm
Weight	300 kg

The following additional data are available depending on the type of handling:

2.5.1.1 GARDEN 1000 – G-003/10

ELECTRO-HYDRAULIC CONTROL UNIT	
PARAMETER	VALUE
Available power supplies	230Volt- 50Hz Europe
	200Volt-50/60Hz Japan
	110Volt-60Hz USA
Power	1,1 kW
Available controls	Series button panel

3 Safety section

3.1 Environmental working values

The use environment of the machine must be well lit, must not present explosion hazards of any kind and must be protected from atmospheric precipitations.

The machine works properly within the following values:

- Ambient temperature between 5° and 40° C;
- Ambient humidity between 30% and 90% without condensation;

STORAGE: if the machine has been unpacked, store it in a closed space protected from bad weather conditions.

3.2 Sound level

During the normal conditions of use some measurements were made at the workplace and around the machine at a distance of 1 m and at 1.6 m height above the ground.

The survey was carried out with a sound level meter, complying with IEC 651 standard, class 1 and the result of the assessment was lower than the minimum limit of action required by the regulations in force.

3.3 Residual risks



The use of the lifting platform is the absolute prerogative of professional operators and specialized technicians, in compliance with the requirements of Machinery Directive 2006/42/ EC and subsequent updates.

Operators must be in full possession of all physical and mental abilities during the performance of their tasks on the machine; they must not, for example, be under the influence of sedatives, drugs or alcohol.



Before carrying out the work, the Operators must be perfectly aware of the position and operation of all the controls and specifications of the machine indicated in the "EC Use and Maintenance Manual".

It is forbidden to use the lifting platform for a purpose other than those provided by the manufacturer.

Always pay attention to the danger and/or warning signs placed on the machine or in adjacent areas.



The machine must always be operated by only one Operator placed at the **safety distance allowed by the cable length of the control panel.**

The operators standing areas must always be kept clean and free of any oily residues to allow an easy and safe passage.

The putting out of service of the protection and safety devices for protecting the operators is the sole responsibility of the Purchaser or the Machine's user.

Finally, we remind you that the handling, installation, use, maintenance and putting out of service of the machine represent a source of danger if these operations are not performed in compliance with the requirements of this Manual or without the necessary caution and attention required.

(More details regarding the Risk Assessment to be requested from the Manufacturer).

3.4 Operator protections



Before starting any type of work on the vehicle lifting platform, the operator must wear appropriate personal protective equipment (PPE), such as gloves and safety footwear.



Always wear work clothing normally used in the mechanical workshop activity.

3.5 Safety systems

The machine is equipped with a mechanical safety device (Figure 3) consisting of a mechanical safety bar for standing at the working height, with the lower stroke limitation made by lock blocks welded to the lower base.

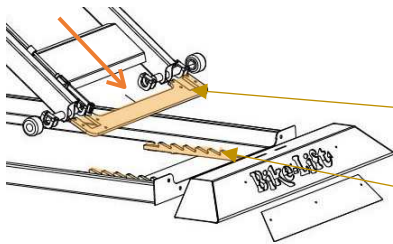

mobile anchoring bar with automatic coupling that prevents the accidental descent of the mobile surface.

mechanical safety system consisting of two toothed bars firmly welded to the base

Figure 3 – Mechanical stop system

The lifting piston has a **parachute valve** that locks the cylinder in case the oil cable is blanked.

In order to make the machine safe during the ascent phase:

- 1- Allow the anchoring bar to move freely around the perimeter of the toothed bar on the base;
- 2- When the selected position is reached, leave the bar uncoupled; this will act as a mechanical stop in case of an uncontrolled fall of the structure.

In order to make the machine safe during the descent phase:

- 1- Hook the anchoring bar to the appropriate lock in order not to hinder the correct descent of the system;
- 2- If the system is brought to the lower stroke (therefore in a position of minimum height), the bar will automatically release to allow the ascent; otherwise, select the chosen position to hook the bar which will act as a mechanical stop in case of an uncontrolled fall of the structure.



ALWAYS keep the mechanical lock hooked during work, in order to weigh down the weight of the structure and of the vehicle standing on it even on the toothed bars at the base.

During the use of the lifting platform it is very important to pay the utmost attention to the ascent and descent maneuvers. During the ascent/descent phase the operator is required to distance from the lifting platform according to the length allowed by the control panel cable.

The personnel who are not in charge of using the vehicle lifting platform must not pass or stand in the operating area of the machine.



The machine must always be operated by only one Operator.



Once the vehicle has been loaded on the lifting platform, position it in a vise (or in case of bikes, use the rear kickstand), then fix it firmly with belts to the appropriate openings and to the wheel lock.



GIVEN THE BEARING VALUE INDICATED ON THE PLATE:

Do not exceed the load capacity of the lifting platform; Use it only to lift objects;
Do not modify the lifting platform;
The load must always remain firm and stable.

3.6 Pictograms

	Danger of crushing hands with the lifting platform arms.
	When the platform is at the desired height, insert the locking bar to prevent it from falling down accidentally.
	Load the vehicle only when the platform is completely lowered; Before lifting it, make sure that nothing is supported by the ramp; Do not lean the rear wheel of the motorcycle on the ramp during and after lifting.

4 Transport and handling section

4.1 Transport, handling and storage



CAUTION: Disseminate the instructions described in this chapter to all personnel involved in the transport and handling of the machine.

For safety reasons, the moving parts must be locked before transport.

4.2 Packaging and transport

The machine is packed for transport directly from the Manufacturer.

It is supplied with a cardboard box and two wooden sleepers (10 cm height) fixed under the lifting platform with special screws. In addition to the lifting platform, the package also contains the ascent ramp (Figure 4, [1]) and the wheel lock tube (Figure 4, [2]).

Figure 4 – Lifting platform model

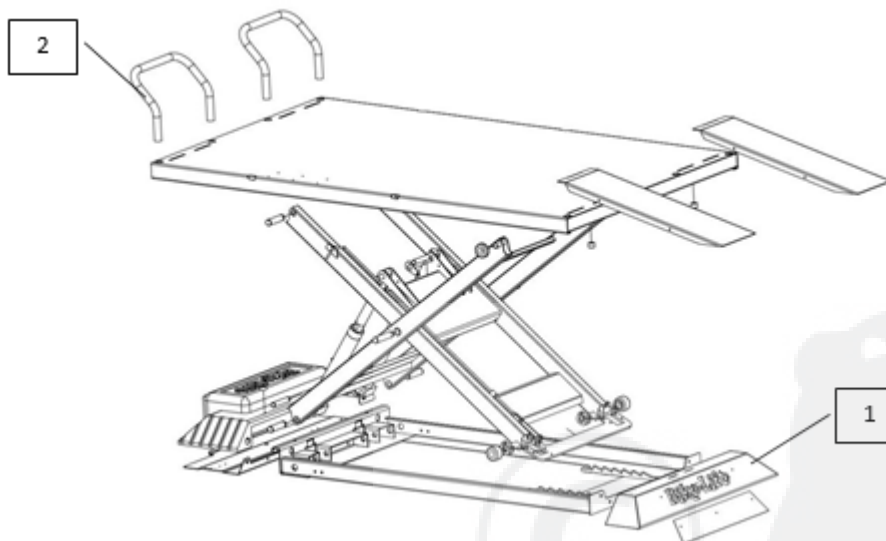

The machine is tested and in perfect condition.

AT CUSTOMER'S REQUEST AND IN ORDER TO AVOID DAMAGE TO THE LIFTING PLATFORM DURING TRANSPORT AND HANDLING, A WOODEN CASE PACKAGING IS ALSO AVAILABLE, WHICH HAS AN ADDITIONAL COST COMPARED TO THE STANDARD FREE PACKAGING.

4.3 Unloading and handling

All lifting and unloading operations must be carried out in compliance with current safety regulations.

The cardboard and wooden packagings must be lifted using a forklift truck, by inserting the forks inside the wooden supports.



It is recommended that the unloading or handling operations to be carried out with a forklift truck by a single Operator equipped with workshop gloves, safety footwear and protective helmet, as required by current regulations.



This Operator must pay maximum attention to all transport phases.

Do not allow any other person to stand in the operation area of the forklift truck in order to prevent the accidental fall of the boxes.

During the unloading phase, in any case, pay attention to the vehicles and people in transit.

Make sure there are not many holes in the floor or on the high slope ramps for the vehicle used, in relation to the load carried; always proceed at low speed with the means of transport.

The unloading from the wooden pallet of the cardboard packaging containing the lifting bench, carried out manually by no less than four Operators equipped with workshop gloves, must be done near the location where the machine will be installed.

4.4 Receipt and check

The packaging is made of suitable material and is carried out by expert personnel, but during the journey it is possible to be deteriorated or damaged.

Upon receipt of the machine, immediately check if the packages are clearly damaged. If so, accept the goods with reserve, by making photographic evidence of any damage.

Open the box by cutting the clips and the closing adhesive tape.

Make sure all the material shown on the delivery note is actually present.

Make sure the parts of the machine have not been damaged during transport and notify, within 5 days of receipt, any damage to the Carrier by REGISTERED LETTER (and notify Bike Lift Europe s.r.l.), by presenting photographically documented evidence.

4.5 Storage

Pending to be unpacked and installed, the machine must be stored in a suitable environment in order not to alter its operation.

- Store the packed machine in a closed or covered area above the ground by using sleepers or similar objects.
- Room temperature and humidity: -5°/75 ° C Relative humidity between 30% and 90%.
- Do not overturn the packaging.
- If the machine is stored without packaging, it must be positioned firmly on wooden sleepers and covered with a cloth.
- Do not stack anything on the machine.

5 Installation section

The machine must be installed in compliance with the safety regulations and instructions included in this chapter.



CAUTION: COMPLETELY remove the wooden sleepers located under the lifting platform by removing the fixing screws before using the machine.

The machine does not need a basis, but requires a flat and horizontal floor. The floor must be able to support a minimum weight of 500 kg/m²•

The lifting platform must be placed in such a way as to allow the Operator to easily repair the vehicles.

The lifting platform must therefore be installed by taking into account the minimum distances from walls or other possible boundaries (boundaries are imaginary lines that delimit the work or safety areas of other machines or structures).

The ascent/descent ramp must be positioned so that the vehicle can be easily lifted. The ramp must not be directed towards an obstacle that is too close to the vehicle lifting platform.



WARNING: It is absolutely forbidden to position the lifting platform on bumpy or inclined ground.

Bring the machine to the place of installation by using a mechanical lift, unpack it and place it in the chosen area.

To install the machine, fix it to the floor with 4 dowels M10 x 100 mm, using the appropriate holes (used to fix the sleepers).

5.1 Power

Electric pump - Connect the electric cable to the power grid using the plug (not supplied), according to the regulations in force in the Country of use. The socket must be grounded.

TECHNICAL DATA OF THE ELECTRIC MOTOR:

Use voltage: 220/230 V. Frequency: 50 Hz. Absorbed power: 1kW Use voltage:

110/115 V. Frequency: 60Hz. Absorbed power: 1kW



WARNING: In the electronic or electro-hydraulic version, the lifting platform is equipped with an electronic board that transforms the low-voltage current (to prevent the electrocution risk. A fuse calibrated on the amperage of the stable 230V power supply is located inside this board.



It is forbidden to replace/tamper with this fuse with one of a higher resistance/amperage

5.2 Putting into service

The tests to be carried out before using the machine have the task of verifying that the mechanical and electrical installation (in the electro-hydraulic pump versions) has been carried out correctly and there are no breakages or damages that could compromise the proper functioning and the performance of the machine.

Make sure:

- There are no signs of obvious breakage or damage to the mechanical structures;
- The mechanical safeties previously described are functioning;
- The connecting pipe between the pump and the hydraulic cylinder does not have any cracks and is in good condition;
- All the seegers placed on the pins are installed correctly

In the versions equipped with electro-hydraulic pump, also check that:

- The electric cable and plug protections (not supplied, but to be installed by the User in compliance with the Country's regulations) are in perfect condition;
- The power plug is properly inserted in the socket;
- The electrical power wiring between the pump and the socket is well positioned, not twisted, does not interact with the passage routes or the storage spaces and does not interfere with other machineries;
- The connection to the electrical system is suitable for power and amperage in order to power the electro-hydraulic pump (refer to the data on the plate shown on the lifting platform).

Carry out the connection following the instructions contained in the manual supplied with the pumps.

6 Dismantling/scrapping section

6.1 Dismantling

Follow the Regulations regarding the materials dismantling in force in the country where the machine will be dismantled.

Here are some useful indications in case you must disassemble the machine to reassemble it in other areas, store it or demolish it.

6.2 Mechanical dismantling

Before proceeding with mechanical dismantling of the machine, carefully clean the whole structure (see **Cleaning and Maintenance**).

Before removing the machine from its housing, remove all moving parts by proceeding to the opposite of what is described in the **Installation** chapter.

For the lifting modes and the relative specific safety precautions, refer to the **Transport, Handling and Storage** chapter.

6.3 Scrapping

The dismantling operations of the machine must be carried out in total safety by using the protections.

At the end of the machine's life it is necessary to proceed to the proper dismantling of the components that are listed with reference to the interested party:

- Support structure: Fe 360/S235
- Hydraulic cylinder: Fe 360/S235
- Paint: Epoxy powder
- Gaskets: Polyurethane rubber
- Oil: Hydraulic ISO VG 10 (W32)

Demolish the different types of machine components in appropriate landfills. Always comply with the Legislation in force in the Country where the machine is used.

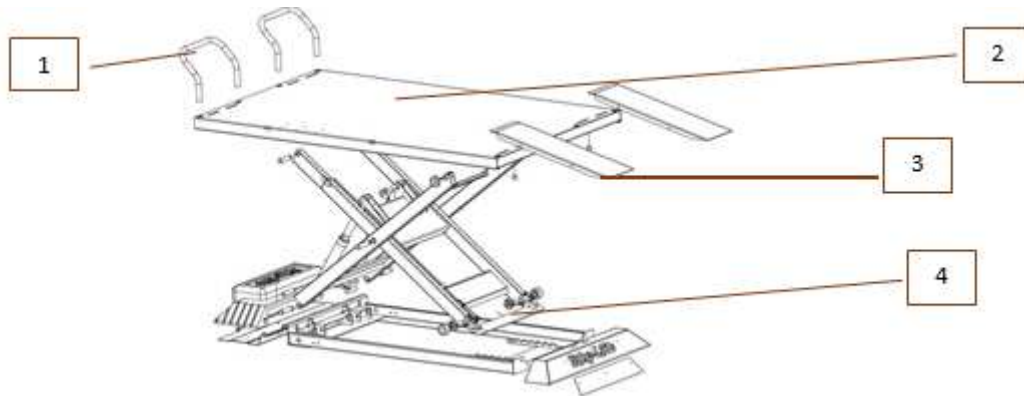

Figure 5 – general model of a lifting platform

7.1 Loading operations

Before installing the vehicle on the platform it is essential to use the wheel lock (Figure 5, [1]), to check that the work surface (Figure 5, [2]) is completely lowered and the **ascent ramp** (Figure 5, [3]) is properly positioned.

- 1- Load the vehicle on the work surface [2], by passing it on the ascent ramp [3];
- 2- (In the case of a two-wheeled vehicle) Place the motorcycle on its center kickstand (if it does not have a central kickstand, use one of our rear kickstand). **Do not lift the motorcycle leaning on the side kickstand;**
- 3- Tie the vehicle with the belts (available on request) to make it more stable.

WARNING: Never lift the load before making sure it is firmly fastened to the platform with belts.



Always check during lifting that the load does not slope and unbalance;
During the ascent/descent phase the operator is required to distance from the lifting platform according to the length allowed by the control panel cable.

Proceed with the lifting operation of the structure according to the following, depending on the type of lifting available.

Once the working height has been reached, slightly lower the lifting platform in order to make sure that the safety bar (Figure 5, [4]) is leaning against the stop locks; otherwise, continue the ascent until the bar exceeds the stop locks located at the base of the lift for the chosen working height;



ATTENTION: Do not operate without the safety bar.

If necessary, the ascent ramp can be removed, to allow the operator to work without disturbance even in the rear part of the vehicle.

7.2 Unloading operations

- 1- Reassemble the ascent ramp;
- 2- Make sure that the scissor sliding guides are free from foreign bodies (bolts or other objects would stop the descent and could cause serious damage or dangerous jolts);
- 3- Use the pump to raise the lifting platform with about 3 cm then release the safety bar (Figure 5, [3]) through the special lever placed sideways. Operate the descent control;
- 4- When the descent is completed, remove the belts;
- 5- Open the locking vise of the front wheel (if present); 6 - Lower the vehicle using the brakes to stop the stroke

7.3 Lifting types

7.3.1 ELECTRO HYDRAULIC PUMP - element code - 003

Lifting takes place using the button panel connected to the hydraulic pump.

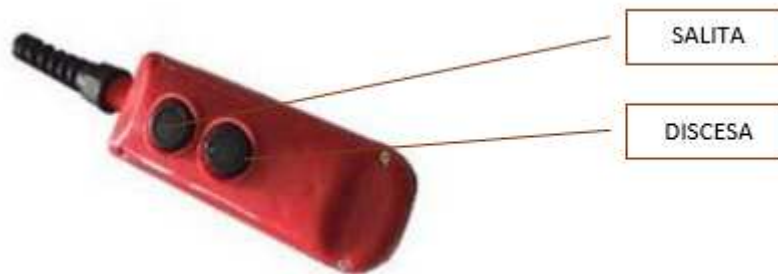

Figure 6 – button panel with magnet for the ascent/descent control

The button panel is equipped with two buttons with maintained action that allow the ascent and descent. Once the controls are released the lifting platform stops instantly. The button panel is equipped with a safety system that stops the operation of one of the two buttons if the other is activated.

7.3.2 ELECTRONIC WITH REMOTE CONTROL - element code 004/R

Lifting is carried out by using a remote control connected to the hydraulic pump via a remote control radio receiver.



Figure 7 – remote control button panel with maintained action control

The remote control is equipped with two buttons with maintained action that allow the ascent and descent. Once the controls are released the lifting platform stops instantly.



The maintenance operation is the absolute prerogative of professional operators and specialized technicians, in compliance with the requirements of Machinery Directive 2006/42/ EC and subsequent updates.

As routine maintenance, the following checks/operations must be carried out **once a month**:

- Visually check the entire machine to make sure that the structures are not deformed or cracked.
- Check the weldings and the proper functioning of the safety devices.
- Make sure the machine ascends and descends smoothly.
- Check that the connecting pipe between the pump and the hydraulic cylinder does not have cracks or unusual deformations, otherwise replace it by following the installation operations of the pump ("Putting into service").
- If necessary, add hydraulic oil to the pump by using the special level plug. Use MOTOREX COREX HLF-D 32 hydraulic oil or equivalents.

8.1 Lubrication

Check and grease the scissor sliding guides frequently.

Lubricate the pins and moving parts at least once a month. In case of continuous use, lubricate every 15 days.

8.2 Bleeding of the hydraulic circuit

To carry out the bleeding of the hydraulic circuit follow the steps:

- 1- Raise the platform using the ascent button to the maximum mechanical safety position;
- 2- Remove the safety bar, then use the descent button to lower the platform;
- 3- Repeat the operations from points 1) and 2) a few times to eliminate any air bubbles in the hydraulic circuit.

Once performing these operations, the platform will ascent properly. If, after performing the previous operations, the platform does not lift properly, repeat the operations from points 1) and 2).

8.3 Piston replacement

In case the hydraulic piston must be replaced, proceed as follows:

- 1- Lower the lifting platform to the minimum height position;
- 2- Maintain the lowering control of the lift for another 6 seconds, to empty the oil;
- 3- A second operator must lift the lifting platform by hand up to about 500 mm from the ground; the fall protection device (once the lift has been brought to the minimum height) will be unhooked and will be able to fit inside the nearest pawl;
- 4- The pistons are empty, so they can be disassembled by unscrewing the support screws, the pin (top) and the oil tube (bottom):



Figure 8 – hydraulic pistons

- 5- The pistons are replaced (one at a time) by tightening the screws and pin and reconnecting it with the hydraulic circuit;
- 6- Keep the ascent button pressed for as long as necessary for the pistons to re-fill and start the lifting operation;
- 7- Then proceed with the operation of bleeding the hydraulic circuit (Paragraph 8.2)

Piston maintenance:

It is recommended to consider the following aspects:

- The results of the checks and maintenance must be planned and documented;
- Check the oil leaks from the oil nozzle and/or leaks on the heads
- Set the lubrication intervals for spherical joints, supports and all components that are not self-lubricated
- The stem must always be retracted during long-lasting machine downtime

8.4 Cleaning

8.4.1 Initial cleaning

The machine does not require particular initial cleaning, but it is a good practice to clean the transit areas of the vehicles by removing the oils and dust to prevent the slip during loading.



Wear water-repellent gloves. Perform the cleaning operations wearing anti-cut gloves resistant to the substances used (follow the safety data sheet).



WARNING: Make sure there are no foreign bodies inside the lifting platform and especially in the sliding guides of the scissors and on the rack (6) where the safety bar operates.



ATTENTION: Any cleaning and maintenance operation must be carried out with the safety bar inserted.

Keep the operator's work area clean.

The cleaning operations concern:

- The machine in general;
- The operator's standing areas.

Dispose the liquids and consumables used in the appropriate landfills, according to the legislation of the Country.

The cleaning of the lifting platform can be carried out by personnel without specific technical skills, who however know the main characteristics of the machine in order to avoid dangerous situations.

8.4.2 General cleaning of the machine

Perform the general cleaning of the machine weekly with the utmost care.

Remove foreign substances: you can use non-corrosive detergents for ferrous and rubber material. These detergents must not be harmful to the operator (follow the instructions contained in the safety data sheets of the substances used, also for the selection of personal protective equipment worn by the operator during work).



The use of water jets and flammable liquids is FORBIDDEN.



The use of self-cleaning cloths is recommended.

The support surfaces and locking blocks of the safety bar must be carefully cleaned to remove traces of oil or grease.

8.4.3 Cleaning the work areas

Keep the work area clear of any material that may hinder the operations of the employees. Keep the surrounding areas clean; in particular from oil, grease, etc. that can make the floor slippery.

Use suitable vacuum cleaners and proper equipment.

8.5 Problems and remedies

The most common problems encountered during the work, the probable causes that determine them and the possible remedies to be taken to eliminate them are listed below.

When implementing the suggested remedy, always follow the instructions described in the Instructions to which the remedy refers.

Bike-Lift Europe s.r.l. will solve all the problems that cannot be eliminated by means of the attached instructions.

The motor housing (Figure 13) that activates and moves the platform is placed at the base of the piston.

The foot and air pumps are, on the other hand, external and for their maintenance refer to the intended manual.

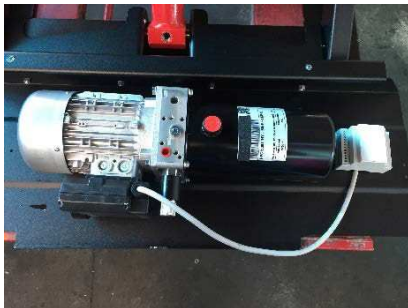
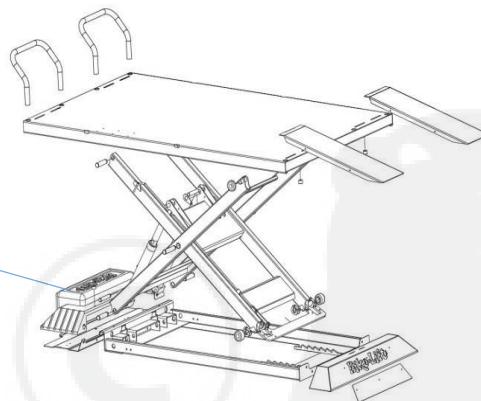

Figure 9 – electric motor



8.5.1 ELECTRIC PUMP

PROBLEM	PROBABLE CAUSE	REMEDY
The lifting platform during the ascent and/or descent vibrates excessively or	Air present in the Hydraulic circuit.	It is necessary to bleed the hydraulic circuit by lifting and lowering the lifting platform a few times.
The lift climbs slowly and with difficulty	Oil too viscous	If the air temperature falls below $-6^{\circ}/-10^{\circ}$ C, the oil decreases its fluidity. To solve this problem, lift and lower the lift a few times so that the oil increases its temperature.
Operating on the button panel, the motor runs but the lift does not rise.	Oil level in the pump too low.	Remove the casing of the pump and check the oil level through the plug (Figure 16). If the level is too low, add ISO VG 10 hydraulic oil.
	Hydraulic pump problems	Contact the dealer or Bike-Lift - Europe s.r.l.
Operating on the button panel the motor does not run	The emergency stop (red button in case of the built-in lifting platform version) on the button panel is inserted	Release the red button on the button panel by turning it clockwise.
	No voltage	Check the mains connection plug
	Improper operation of the button unit on the button panel	Replace the button unit
	The motor is short-circuited	Contact the dealer or Bike-Lift - Europe s.r.l.

PROBLEM	PROBABLE CAUSE	REMEDY
Operating on the button panel the lifting platform does not descend	The emergency stop (red button in case of the built-in lifting platform version) on the button panel is inserted	Release the red button on the button panel by turning it clockwise
	No voltage	Check the mains connection plug
	Improper operation of the button unit on the button panel	Replace the button unit
	Problems with the solenoid valve which controls the descent of the pump	Replace the solenoid valve (Figure 10)
IN CASE OF POWER FAILURE, USE THE SAFETY VALVE WHICH CAN BE OPERATED MANUALLY BY TURNING IT COUNTERCLOCKWISE TO ALLOW THE DESCENT OF THE LIFTING PLATFORM.		

Figure 10 – electric motor



9  Accessories

GARDEN 1000

BASIC EQUIPMENT	
PARAMETER	VALUE
Motorcycle wheel stop	2 pcs
Ascent ramp	2 pcs



SPARE PARTS - TECHNICAL DRAWINGS

9.1 GARDEN 1000



