

BRINLY

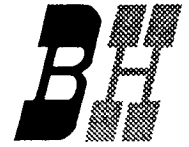

OWNER'S MANUAL

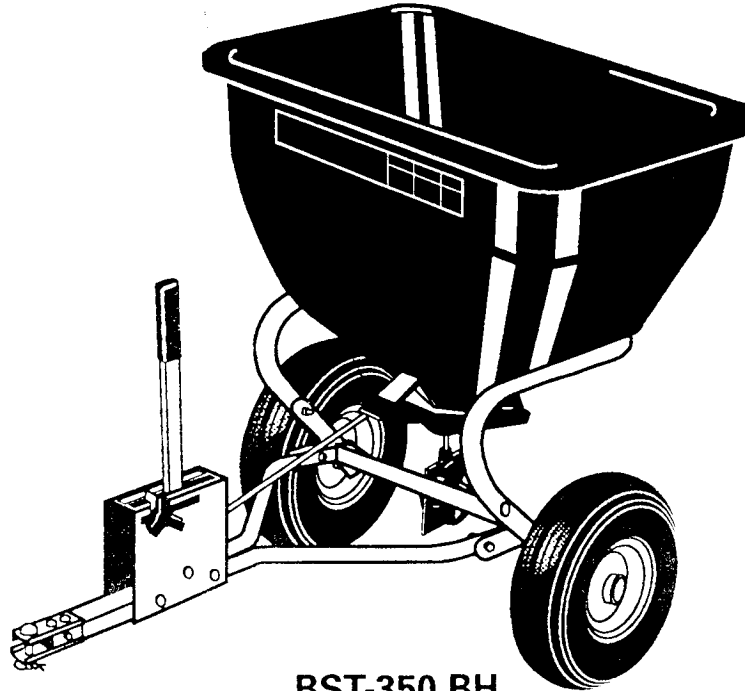

**BST-350 BH
BROADCAST SPREADER
MODEL - BST-3500 BH**

"IMPORTANT: THIS MANUAL CONTAINS INFORMATION FOR THE SAFETY OF PERSONS AND PROPERTY. READ IT CAREFULLY BEFORE ASSEMBLY AND OPERATION OF THE EQUIPMENT!"

LIMITED WARRANTY

Brinly-Hardy Company warrants only to the original retail purchaser that this product will remain free of defects in workmanship and materials under normal use and service for a period of two (2) years (NOTE: ninety (90) days for commercial or rental use) commencing with the date of purchase.

Any parts found to be defective within the warranty period will be replaced, with proof of date of purchase, at Brinly-Hardy Company's expense. Our obligation under this warranty is expressly limited to replacement or repair at our option of parts which are defective in material or workmanship within thirty (30) days of receipt of the parts. This warranty does not apply to damage caused by unreasonable use, including failure to provide necessary maintenance, nor does it apply to any transportation or labor charges.

WE MAKE NO OTHER EXPRESS WARRANTY, NOR IS ANYONE AUTHORIZED TO MAKE ANY ON OUR BEHALF. ANY IMPLIED OR STATUTORY WARRANTIES, INCLUDING ANY WARRANTY OF MERCHANTABILITY OR FITNESS FOR A PARTICULAR PURPOSE, ARE LIMITED TO THE DURATION OF THIS WRITTEN WARRANTY. WE SHALL NOT BE LIABLE FOR CONSEQUENTIAL OR INCIDENTAL DAMAGES OF ANY KIND.

MADE IN U.S.A.

BRINLY-HARDY COMPANY (502) 585-3351

INTRODUCTION

Thank you for buying this quality product! Your Broadcast Spreader is equipped with a bevel gear drive system. It is recommended for use with all granular material (maximum granular size 3/16"), such as fertilizer, seed, sand, salt, ice melters, etc. This Spreader is NOT recommended for spreading powdered materials such as Hydrated Lime.

Please read and retain this manual. The instructions will enable you to assemble and maintain your implement properly. Always observe the "SAFETY RULES".

Should the need ever exist for repair parts, order through most any Lawn and Garden Dealer, using part number and description.



RULES FOR SAFE OPERATION

- Know controls and how to stop quickly, READ THE OWNER'S MANUAL.
- Do not allow children to operate the vehicle. Do not allow adults to operate without proper instruction and without having read the owner's manual.
- Do not carry passengers. Keep children and pets a safe distance away.
- Always wear substantial footwear. Do not wear loose fitting clothing that can get caught in moving parts.
- Keep your eyes and mind on your tractor/attachment and area being covered. Don't let other interests distract you.
- Stay alert for holes in the terrain and other hidden hazards.
- Keep the vehicle and attachment in good operating condition and keep safety devices in place.
- Keep all nuts, bolts and screws tight to be sure the equipment is in safe working condition.
- The vehicle and attachment should be stopped and inspected for damage after striking a foreign object. The damage should be repaired before restarting and operating the equipment.
- See tractor equipment owner's manual for safe operation of the equipment.
- Do not drive close to creeks, ditches and public highways.
- Watch out for traffic when crossing or near roadways
- When using any attachment, don't allow anyone near the vehicle while in operation.



WARNING

- Always operate your spreader within the speed limit for which it was designed - 3 to 4 MPH.
- When backing - carefully back straight to avoid jack knifing which could result in damage to equipment.
- Shutter plate may have sharp edges for spreading. Handle with caution. Work gloves are recommended to avoid injury.
- Only tow your spreader behind vehicles for which it was designed - riders, lawn/garden tractors, and ATVs.
- Lock nuts must be used where specified. They have a slightly oblong hole and are domed on one end.
- Do not load the hopper with more than the maximum weight capacity of 125 (BST-250) or 175 (BST-350) pounds.

CUSTOMER RESPONSIBILITIES

- Read and observe the "SAFETY RULES"
- Follow a regular schedule in maintaining, caring for, and using your Attachment.

TABLE OF CONTENTS

WARRANTY	1	OPERATION	7
SAFETY RULES	2	MAINTENANCE	7
HARDWARE	3	REPAIR PARTS	8
ASSEMBLY	4, 5 & 6		

HARDWARE

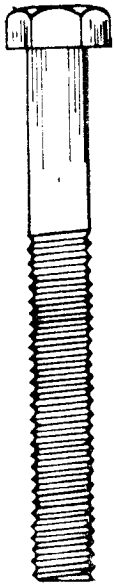

No. 23
1M1032P
5/16" x 2"
Hex Bolt

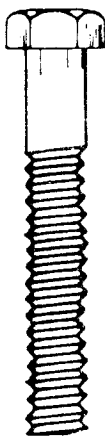

No. 24
1M1024P
5/16" x 1 1/2"
Hex Bolt

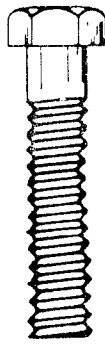

No. 40
45M1111P
5/16" Flat Washer

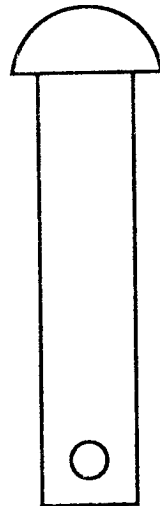

No. 43
B-3861
Drawbar Pin

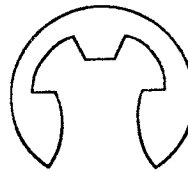

No. 6
F-577
"E" Type
Snap Ring



No. 32
45M2121P
5/8" Flat Washer

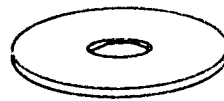

No. 48
R-618
5/16" Heavy Washer



No. 55
45M0909P
1/4" Flat
Washer



No. 36
F-787 Curve &
Spring Washer



No. 20
B-4786
5/16" Nylon
Insert Nut



No. 46
B-1674P
5/16" Hex
Lock Nut



No. 16
B-4785
1/4" Nylon
Insert Nut



No. 7
B-1673P
1/4" Hex
Lock Nut

No. 39
1M1044P
5/16" x 2 3/4"
Hex Bolt



No. 8
F-575 1/4"
Thrust Washer



No. 30
F-595
Lock Clip



No. 29
F-591 Fan Driver

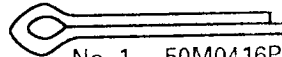

No. 1 50M0416P
1/8" x 1" Cotter Pin



No. 9
F-313 1/4"
Gate "O" Ring



No. 3
F-365 3/8"
I.D. "O" Ring

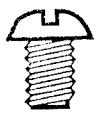

No. 12
20M0808P
1/4" x 1/2"
Round Head
Screw



No. 19
20M0814P
1/4" x 7/8"
Round Head
Screw

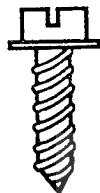

No. 54
F-395
1/4" x 3/4"
Hex Head
Screw

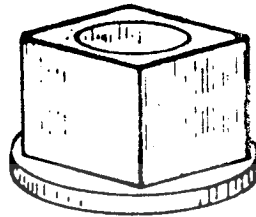

No. 22
F-283 5/8" I.D.
Axle Bearing

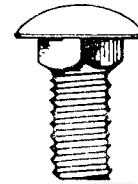

No. 35
10M1012P
5/16" x 3/4"
Carriage Bolt

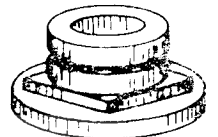

No. 5
F-574 Fan Shaft
Bearing w/Groove

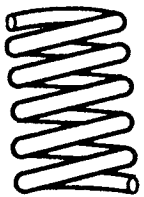

No. 49
B-3805
Latch Spring

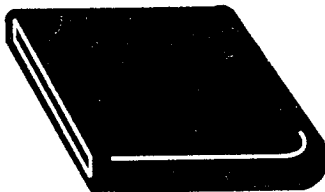

No. 15
F-789 Vinyl Grip (small)

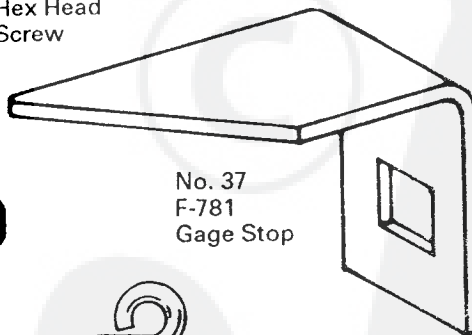

No. 37
F-781
Gage Stop



No. 2
F-436 Torsion Spring Agitator

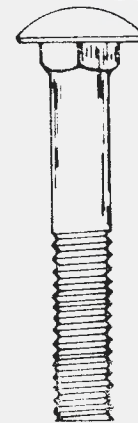

No. 44
10M1032P
5/16" x 2"
Carriage
Bolt

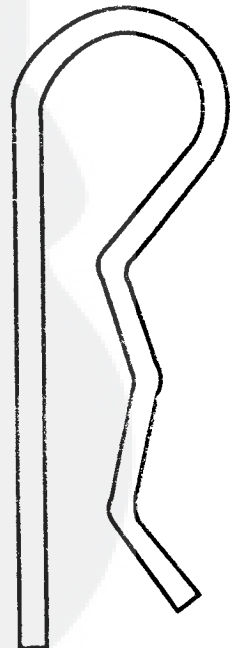

No. 33
F-620 Hairpin Cotter

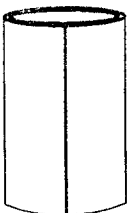

No. 47
B-3721
Latch Spacer

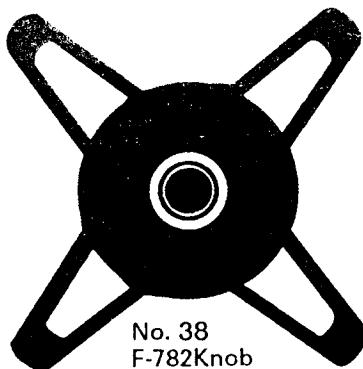

No. 38
F-782 Knob



No. 42
D-146P 1/8" Hairpin Cotter

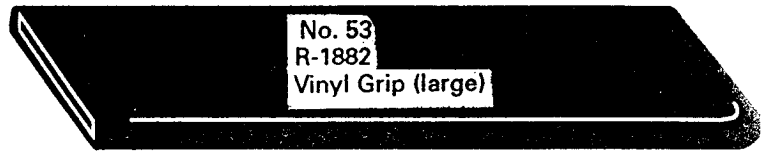
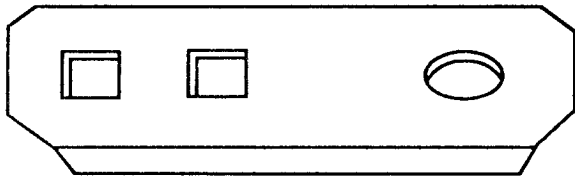

ASSEMBLY

TOOLS REQUIRED FOR ASSEMBLY:

- 1 - Pair of Pliers (Slip-joint recommended).
- 1 - Screwdriver (Flat).
- 1 - 7/16" Wrench.
- 2 - 1/2" Wrenches.
- 1 - Pair of Work Gloves.

Refer to FIG. 1.

- Turn Hopper on its back (side opposite Operation Decal) and insert the grooved Fan Shaft Bearing through square hole in bottom of Hopper, from INSIDE of Hopper. Secure by pressing a Snap Ring into Bearing Groove from outside.

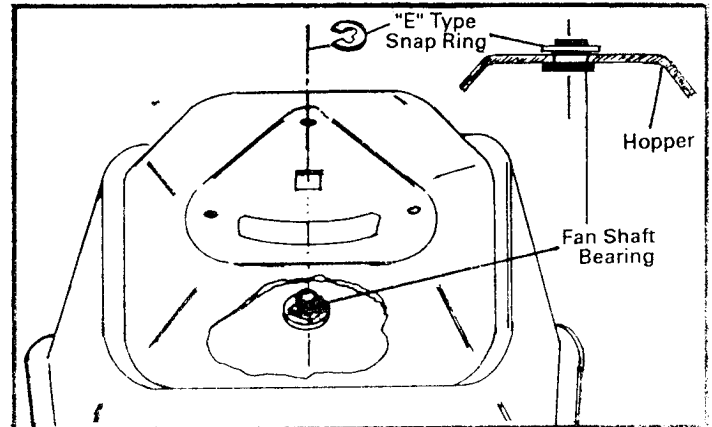

FIG. 1.

Refer to FIG. 2.

- Pre-assemble the Directional Handle, positioned behind Lip as shown, to the Directional Shutter Plate using two 1/4" x 1/2" Round Head Screws and Nylon Insert Nuts. Tighten securely. See Inset.

- Install Vinyl Grip onto (Shutter) Directional Handle.
- Place the Shutter and Handle Assembly over flat area of Hopper bottom as shown. Align small hole in Shutter with small hole at rear of Hopper. Slots in Shutter will align with two small holes toward front of Hopper.

- Position the Flow Control Plate (as shown) over top of Shutter Plate. Align the three slots with those in Shutter Plate and Hopper.
- Insert three 1/4" x 7/8" Round Head Screws, with Nylon Washers next to heads, from outside of Hopper to inside. Place a small rubber "O" Ring and another Nylon Washer on Screws at inside of Hopper. Secure using three 1/4" Hex Lock (domed) Nuts.

IMPORTANT — Do not overtighten Lock Nuts - Plates must be free to move with a slight amount of resistance.

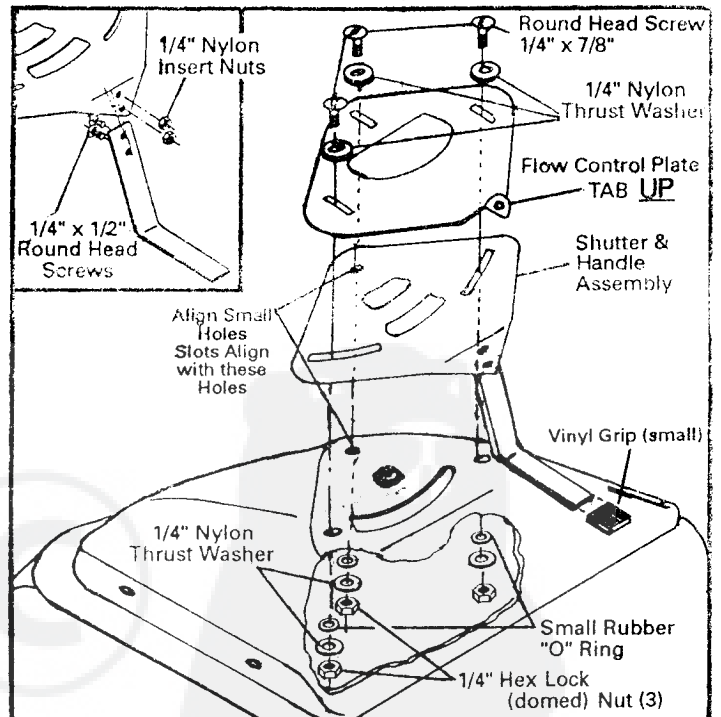

FIG. 2.

Refer to FIG. 3.

- Inspect the Gearbox Assembly and note the following: The Fan Shaft extends from the center of the Gear Housings at the Gearbox Cap and is smaller in diameter than the Axle which extends from the end of each Gearbox Housing Half.

- Slide the Lock Clip down the Fan Shaft with a pair of pliers, then slide the Fan Driver (WITH THE LARGE DIAMETER FLANGE FACING UP) down the Shaft and follow with Fan.

Note: These parts will fit tight.

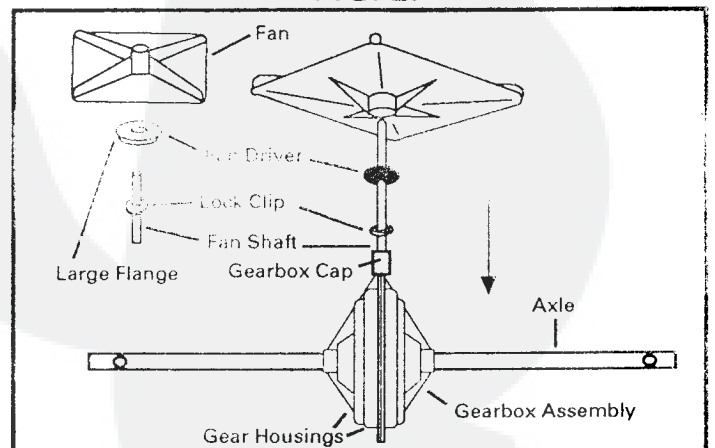

FIG. 3.

Refer to FIG. 4.

NOTE: The Shutter Plate and Flow Control Plates protrude from the FRONT of the Hopper.

- While looking at the REAR of the Hopper (and it is still upside down), insert the Fan Shaft of the Gearbox Assembly into the Fan Shaft Bearing in Hopper.

- Slip one end of the Hopper Support (each end has a square hole) onto one end of Axle, then slip the other end of the Hopper Support onto the other Axle end and sit the Hopper Support on the REAR of Hopper. (Positioned at the six mounting holes in Hopper).

- The rotation of the Fan must now be determined. Grasp the Axle and rotate it toward you and observe the direction that the Fan is rotating - it MUST turn CLOCKWISE.

NOTE: Should the Fan be found to rotate COUNTER-CLOCKWISE, remove the Hopper Support, rotate the Gearbox Assembly to your right - CLOCKWISE, 1/2 a complete rotation. Relocate the Hopper Support and again check the Fan rotation to be sure it is now rotating Clockwise.

- Secure the Hopper Support to the Hopper with six Hex Head Screws and six 1/4" Flat Washers - installed from inside the Hopper. Tighten these Screws securely.

- Adjust the Fan Assembly by slipping the components down toward the Fan Shaft Bearing until the Fan almost touches the Bearing. Be sure the Fan Driver is pushed down between the ribs on the bottom of the Fan and that the Lock Clip is against the Driver.

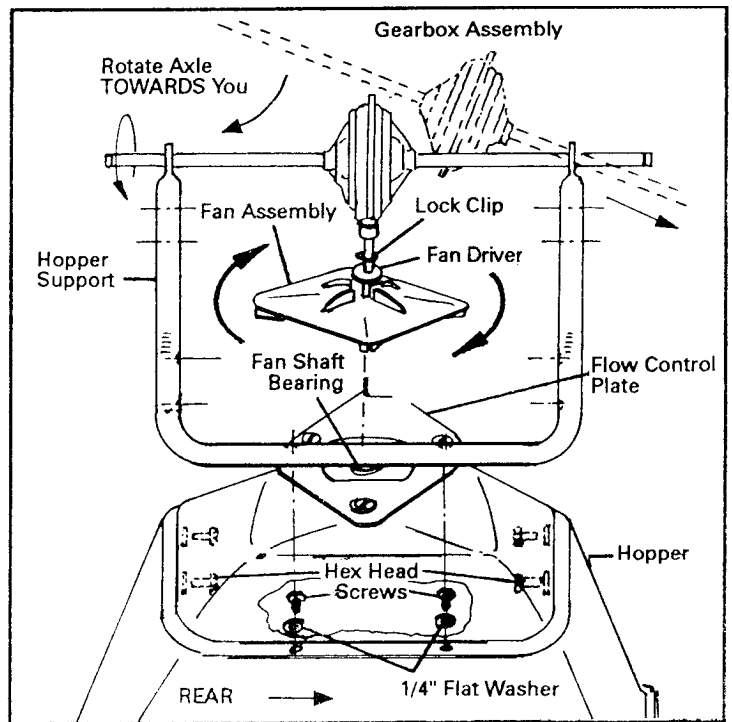

FIG. 4.

Refer to FIG. 5.

- Assemble the two Gusset Plates to insides of Hopper Support (at upper hole only in each side) using two 5/16" x 2" Hex Bolts and Nylon Insert Nuts.

NOTE: Gussets extend towards front of Hopper.

- Align lower holes in Gusset Plates and Hopper Support. Tighten the upper Bolts securely.

- Assemble Cross Brace and the two Tow Tubes (short ends) to lower holes at inside of Hopper Support and Gusset Plates. Secure with two 5/16" x 2" Hex Bolts and Nylon Insert Nuts.

- Align forward holes in Tow Tubes and Gussets, secure with two 5/16" x 1 1/2" Hex Bolts and Nylon Insert Nuts. Tow Tubes will be side by side at front.

- Assemble the two Hitch Clevis' above and below the front of the two Tow Tubes, using two 5/16" x 2" Carriage Bolts BETWEEN Tow Tubes opening. Secure with Nylon Insert Nuts, do not tighten at this time.

- Insert a 5/16" x 1 1/2" Hex Bolt through holes at front (sides) of Tow Tubes, BETWEEN the Carriage Bolts previously installed. Secure with a 5/16" Nylon Insert Nut. Slide the Hitch Clevis' forward as far as possible and tighten all three Bolts securely.

- Install Hitch Pin in front hole of Clevis, securing with small Hairpin Cotter.

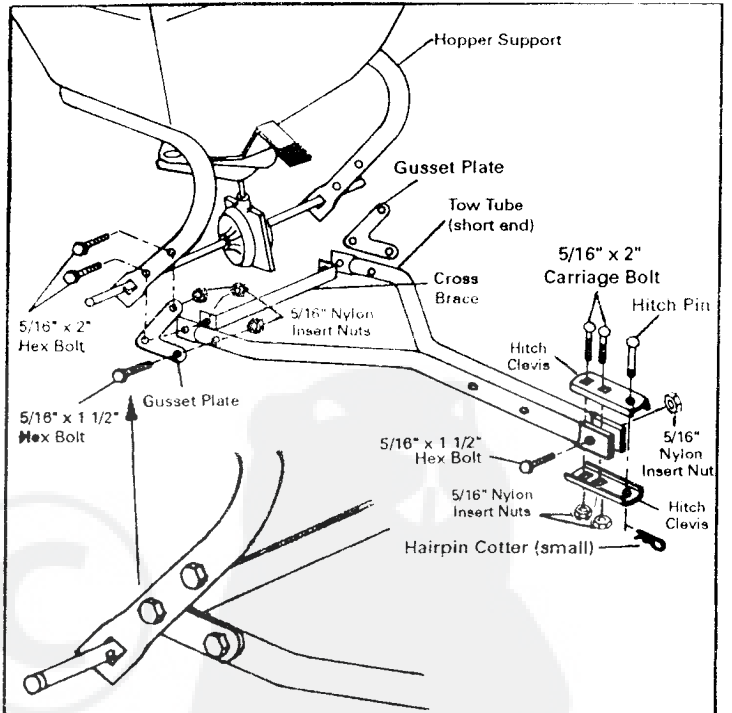

FIG5.

Refer to FIG. 6.

- Place the Axle Bearings (WITH FLANGES FACING OUTWARD) on the ends of the Axle and insert the Bearings into the square holes in the ends of the Hopper Support.

- Slide two 5/8" Flat Washers on each end of the Axle followed by a Wheel and then another 5/8" Flat Washer.

- Secure each Axle end by snapping a 5/8" Snap Ring onto the groove located at each end of Axle.

- Rotate either Wheel until the hole in the hub lines up with the matching hole in the Axle and then insert one Hairpin Cotter as shown.

- Rotate this "Drive Wheel" - checking the amount of resistance in the Gear and Fan system. If there is any stiffness or binding, realign the Gearbox by either removing one of the 5/8" Flat Washers from behind the non-driving Wheel, or add another Washer behind the same Wheel if there is excessive side movement.

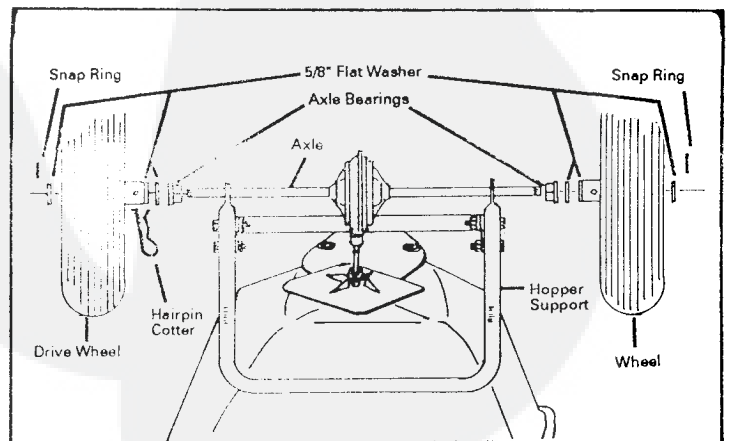

FIG 6.

Refer to FIG. 7.

- Turn the Spreader right side up (on its Wheels) and slip the Fan Shaft "O" Ring onto the Fan Shaft inside Hopper.
 - Install the Agitator Spring with the long leg on the bottom and the small loop at the top - on the Fan Shaft.
 - Align the hole in the Shaft with the Spring's loop and then insert one 1/8" x 1" Cotter Pin (from the loop side) through the assembly and bend the legs over with pliers.
- NOTE: Again check the direction of rotation. While viewing the inside of Hopper from above, the Agitator MUST rotate COUNTER-CLOCKWISE, when pulling the unit forward. If the Agitator rotates clockwise, repeat the steps described in FIGURE 4.

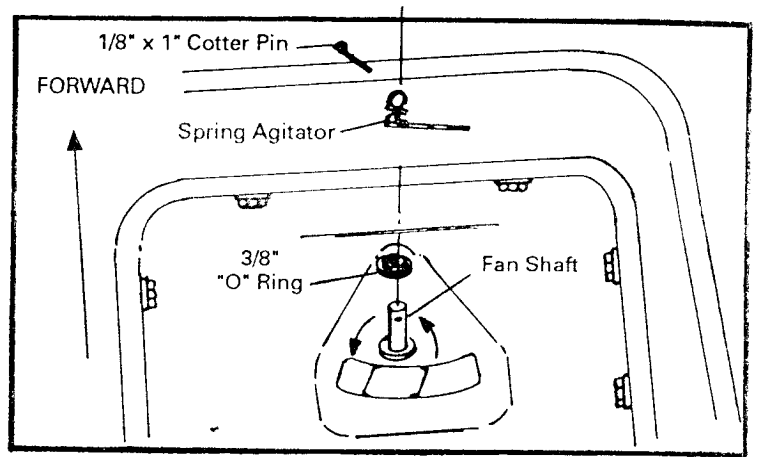

FIG 7.

Refer to FIG. 8.

- Insert double offset end of Link Rod into upper (smaller) hole in Flow Control Handle, rotate 90° and hold in place.
- Locate Gage Plate and notice long slot in side near top. With slot towards left side, insert Flow Control Handle and Link Rod through longer slot in top with Link Rod to REAR.
- Align lower hole in Flow Control Handle with hole located in center of Gage Plate. Assemble using the Spacer at one side of Handle and two heavy Washers, with Spring between them, at other side. Secure with 5/16" x 2 3/4" Hex Bolt, two 5/16" Flat Washers (at outsides of Gage Plate) and Hex Lock (domed) Nut. Do not tighten at this time.
- Insert other double offset end of Link Rod through formed tab in Flow Control Plate (assembled to Hopper) and rotate 90° as before to install.
- Position Gage Bracket over Tow Tubes, with slots aligned with holes in center of Tow Tubes. Secure with two 5/16" x 2 3/4" Hex Bolts, four 5/16" Flat Washers (next to slots in Gage Bracket) and two 5/16" Nylon Insert Nuts. Tighten these Bolts and Handle Mounting Bolt until snug, with Gage Bracket barely free to move (will be adjusted and tightened later).

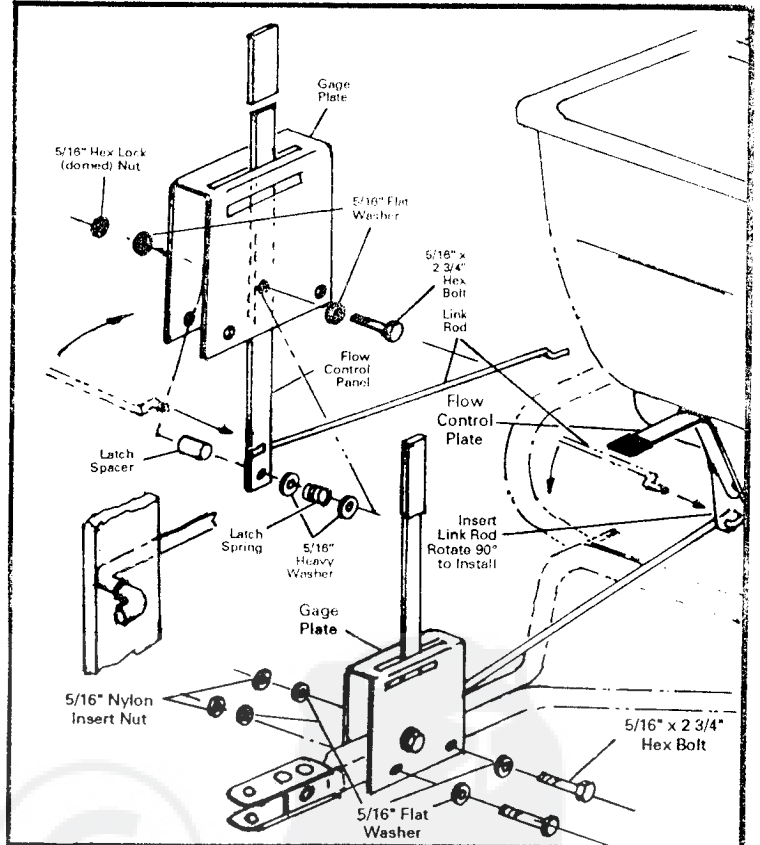

FIG. 8.

SHUTTER CALIBRATION

Refer to FIG. 9.

- Move Flow Control Handle BACK to within approximately 1/2" from edge of slot.
 - Observe Shutter Plate from inside Hopper: Edge of Shutter Plate must be even with front edge of Hopper Slot opening (closed position).
- TO ADJUST:
- Slide Gage Bracket front or back to obtain this position.
 - Tighten the two Bolts securing Gage Bracket to Tow Tubes securely.
 - Check closed position - Handle will be in CLOSED position (approximately 1/2" from end of slot) with opening in Hopper closed off. Apply Flow Control Decal to RIGHT side of Gage Bracket, with "O" mark at front side of Flow Control Handle.
 - Move Flow Control Handle to "10" position and observe Shutter Plate inside Hopper. Front edge of Shutter Plate opening will align with front edge of Hopper opening.
 - Attach the Stop Gage to top of Gage Plate using a 5/16" x 3/4" Carriage Bolt with Spring Washer from inside Gage Plate, through slot at left side. Secure with Plastic knob from outside.
 - Install large Vinyl Grip on Flow Control Handle.
 - Install Directional Decal onto (shutter) Directional Handle.
 - Slip Clear Cover over top of Hopper (Cover will be difficult to assemble first time and may require help stretching it over hopper). Your unit is now ready for use. Recheck all hardware for proper tightness according to these instructions.
 - If Logo Decal is not applied to front of Hopper, see parts page (8) for location.

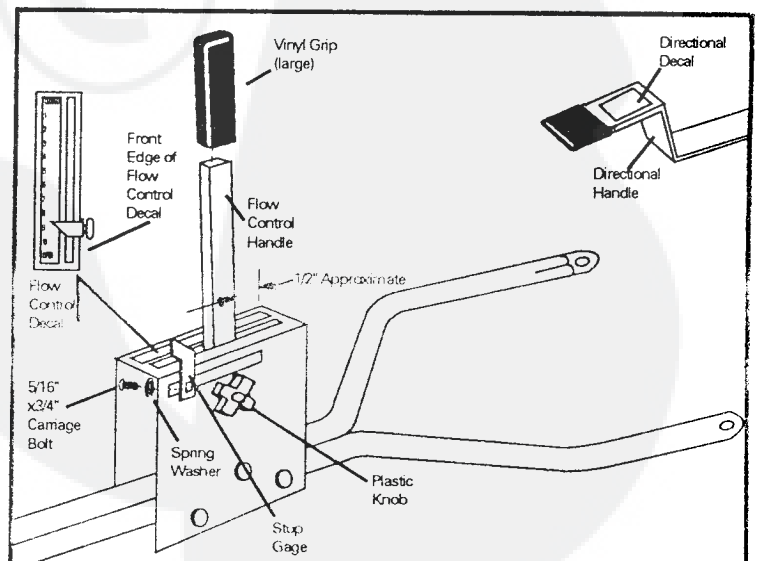

FIG 9.

OPERATION

- The Fan speed and the spread width are controlled by the speed at which you operate the Spreader. The recommended operating speed is slightly faster than that of a brisk walk, 3 to 4 MPH.
- The Flow Control Handle operates the Flow Control Shutter. The Flow Control Decal is marked 0 (closed) to 10. The position selected determines the amount of material to be broadcast. The higher the number, the heavier the application of material. NOTE: Close Shutter before filling Hopper. Keep the Plastic Knob and Stop Gage tight at all times.
- The Directional Handle controls material spread pattern. Adjustment can be made for different density material by moving the Handle to the RIGHT or LEFT. Handle moves OPPOSITE the direction you want pattern to move. See Directional Decal on Handle for proper use.



CAUTION

• Do not load the hopper with more than the maximum weight capacity of 125 (BST-250) or 175 (BST-350) pounds.

- Determine the Flow Control number setting required for your job using the Application Rate Chart. After determining the correct setting number for your material, move Flow Control Handle (adjust shutter) to that position. This is done by loosening the Plastic Knob and moving the Stop Gage to this number, then retightening Knob.

OPERATING TIPS

- When spreading ice melters, use 2 Hairpin Cotter - 1 in each Wheel hub, for better traction.
- When spreading seed, fertilizer, etc., insert only 1 Hairpin Cotter in either the right or left Wheel hub.
- Do not fill Hopper and transport over long distances. This may result in packing, causing poor or erratic discharge. Fill only at operation site.
- Break up any lumps as you fill the Hopper.
- Do not use on windy days, especially when spreading fine grass seed or herbicides.
- For best results, select a LOWER (smaller number) Shutter setting and spread material using TWO light applications - use a "criss-cross" or overlap pattern on the second application.

MAINTENANCE

- To ensure years of trouble-free service, clean the Spreader thoroughly with water after each use.
- For rust on frame parts, sand lightly and paint with enamel.
- Periodically lubricate all bearing surfaces.

APPLICATION RATE CHART

Fertilizer application rates (as shown on the chart) are affected by humidity and the moisture content of the material (granular and pellet). Therefore, minor setting adjustments may be necessary to compensate for these conditions.

Material Type	Average Recommended Usage	Speed	Shutter Setting	Spread Width
SEED				
KY BLUEGRASS	2 lb./1,000 sq. ft.	3 MPH	5	7 ft.
RYE	4 lb./1,000 sq. ft.	3 MPH	5	8 ft.
TALL LAWN FESCUE	6 lb./1,000 ft.	3 MPH	5	9 ft.
FERTILIZER				
10-10-10	50 lb./5,000 sq. ft.	3 MPH	7	11 ft.
10-20-10 WONDER GRO	40 lb./10,000 sq. ft.	3 MPH	7	11 ft.
10-18-10 GREEN VIEW WINTER GREEN 2 WAY	20 lb./5,000 sq. ft.	3 MPH	4	7 ft.
18-24-6 SCOTT'S STARTER FERTILIZER	20 lb./3,000 sq. ft. 20 lb./5,000 sq. ft.	3 MPH 3 MPH	6 5	6 ft. 6 ft.
SCOTT'S TURF BUILDER	13 1/4 lb./5,000 sq. ft.	3 MPH	4	6 ft.
LAWN WEED AND INSECT CONTROL				
WONDER-GRO LAWN WEED KILLER	8 lb./5,000 sq. ft.	3 MPH	6	4 ft.
SCOTT'S LAWN INSECT CONTROL	12 1/2 lb./5,000 sq. ft.	3 MPH	4	5 ft.

BST-350 BH

GEARBOX/AXLE ASSEMBLY

TO ORDER PARTS:
 Brinly-Hardy Co.
 P.O. Box 1116
 Louisville, KY 40201
 (502) 585-3351

REF. NO.	PART NO.	DESCRIPTION	QUANTITY
A	F-378	Pinion	1
B	F-454	Gear	1
C	F-457	Pinion Carrier	1
D	F-458-G	Housing Half (Gearbox)	2
E	F-730	Fan Shaft	1
F	F-398	Gearbox Cap	1
G	F-413	Spiral Pin, 5/32" x 1"	1
H	F-414	Spiral Pin, 1/8" x 3/4"	1
I	F-415	Hex Washer Head Screw	4
J	F-731-01	Axle	1

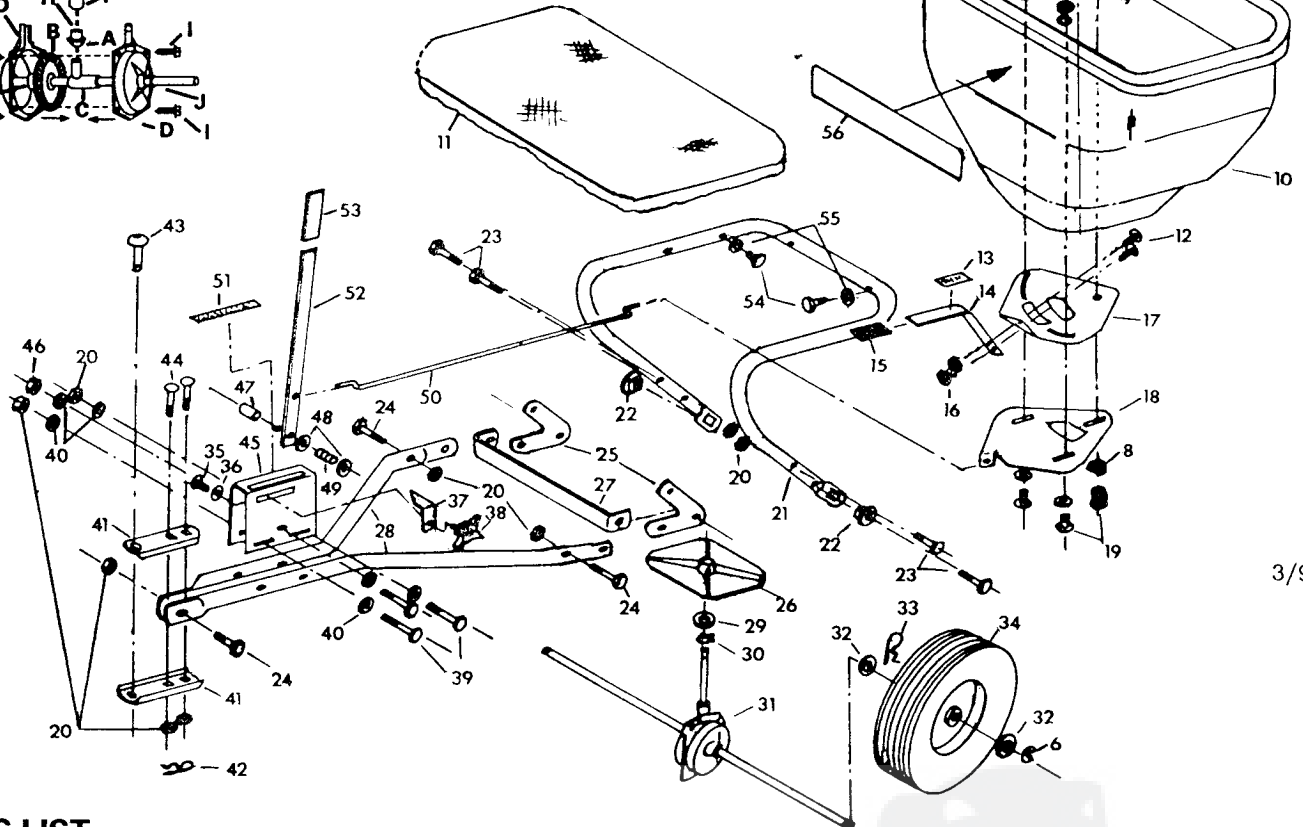
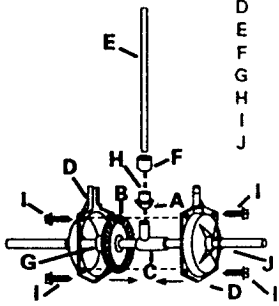

3/97

PARTS LIST

REF. NO.	PART NO.	DESCRIPTION	QUANTITY	REF. NO.	PART NO.	DESCRIPTION	QUANTITY
1	50M0416P	Cotter Pin - 1/8" x 1"	1	29	F-591	Fan Driver	1
2	F-436	Agitator Spring	1	30	F-595	Lock Clip	1
3	F-365	Fan Shaft "O"Ring (large)	1	31	F-770	Gear Box Assembly	1
4	F-778	Logo Decal	1	32	45M2121P	Flat Washer, 5/8"	6
5	F-574	Fan Bearing (small)	1	33	F-620	Hairpin Cotter (large)	2
6	F-577	Snap Ring	3	34	F-705	Wheel	2
7	B-1673P	Hex Lock (Domed) Nut	3	35	10M1012P	Carriage Bolt, 5/16" x 3/4"	1
8	F-575	Nylon Washer	6	36	F-787	Spring Washer, 5/16"	1
9	F-313	Shutter "O" Ring (small)	3	37	F-781	Stop Gage	1
10	F-719	Hopper	1	38	F-782	Knob	1
11	F-745	Moisture Cover	1	39	1M1044P	Hex Bolt, 5/16" x 2 3/4"	3
12	20M0808P	Round Head Screw, 1/4" x 1/2"	2	40	45M1111P	Flat Washer, 5/16"	6
13	F-790	Decal (Directional Handle)	1	41	R-892-10	Hitch Clevis	2
14	F-784	Directional Handle (shutter)	1	42	D-146P	Hairpin Cotter (small)	1
15	F-789	Vinyl Grip (small)	1	43	B-3861	Hitch Pin	1
16	B-4785	Nylon Insert Nut - 1/4"	2	44	10M1032P	Carriage Bolt, 5/16" x 2"	2
17	F-767	Shutter Plate (directional)	1	45	F-762-10	Gage Plate	1
18	F-765	Flow Control Plate	1	46	B-1674P	Hex Lock (domed) Nut, 5/16"	1
19	20M0814P	Round Head Screw, 1/4" x 7/8"	3	47	B-3721	Latch Spacer	1
20	B-4786	Nylon Insert Nut, 5/16"	11	48	R-618	Heavy Washer, 5/16"	2
21	F-755-10	Hopper Support	1	49	B 3805	Latch Spring	1
22	F-283	Bearing Axle (large)	2	50	F-761	Link Rod	1
23	1M1032P	Hex Bolt, 5/16" x 2"	4	51	F-740	Flow Control Decal	1
24	1M1024P	Hex Bolt, 5/16" x 1 1/2"	3	52	F-738-10	Flow Control Handle	1
25	F-758-10	Gusset Plate	2	53	R-1882	Vinyl Grip (large)	1
26	F-573	Fan	1	54	F-395	Hex Tapping Screw, 1/4" x 3/4"	6
27	F-734-10	Cross Brace	1	55	45M0909P	Flat Washer, 1/4"	6
28	F-759-10	Tow Tube	2	56	F-744	Operation Decal	1
				57	L-1552-BH	Instructions	1