



shindaiwa

INSTRUCTION MANUAL MANUAL D'USO

HT230/DH230

HEDGE TRIMMER/TOSASIEPI

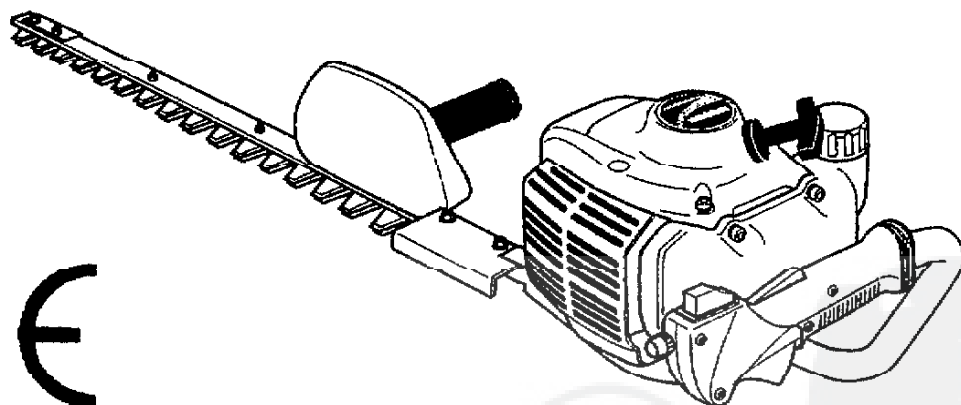

ENGLISH

ITALIAN



WARNING!

Read this manual and familiarize yourself with its contents.

This machine is designed for trimming hedge.

Do not use this machine for other purposes.

Minimize the risk of injury to yourself and others.

Do not operate or service this machine unless you clearly understand this manual.

Keep this manual at a particular place so that you can reread it whenever you have a question about its use.

Contents

	PAGE
1 Attention Statements	1
2 Product Description	2
3 Specifications	3
4 Assembly	5
5 Mixing Fuel	10
6 Filling the Fuel Tank	10
7 Starting Procedure	11
8 Adjusting Engine Idle	14
9 Stopping the Engine	14
10 Operation	14
11 Maintenance and Adjustments ...	17
12 Long Term Storage	20
13 Troubleshooting Guide	21
14 Declaration of Conformity ...	24

1 Attention Statements



WARNING!

A statement preceded by the triangular Attention Symbol and the word **WARNING** contains information that should be acted upon to prevent serious bodily injury.

CAUTION!

A statement preceded by the word **CAUTION** contains information that should be acted upon to avoid damaging your machine.

IMPORTANT!

A statement preceded by the word **IMPORTANT** is one that possesses special significance.



Read and follow this Operator's Manual. Failure to do so could result in serious injury.



Wear eye and hearing protection at all times during the operation of this machine.



WARNING!

The blades are **SHARP!** Handle with care. Keep hands clear of the cutter blades when starting the engine. Do not operate this machine if you are tired, ill or under the influence of alcohol, drugs, or medicine.

2 Product Description

HT230

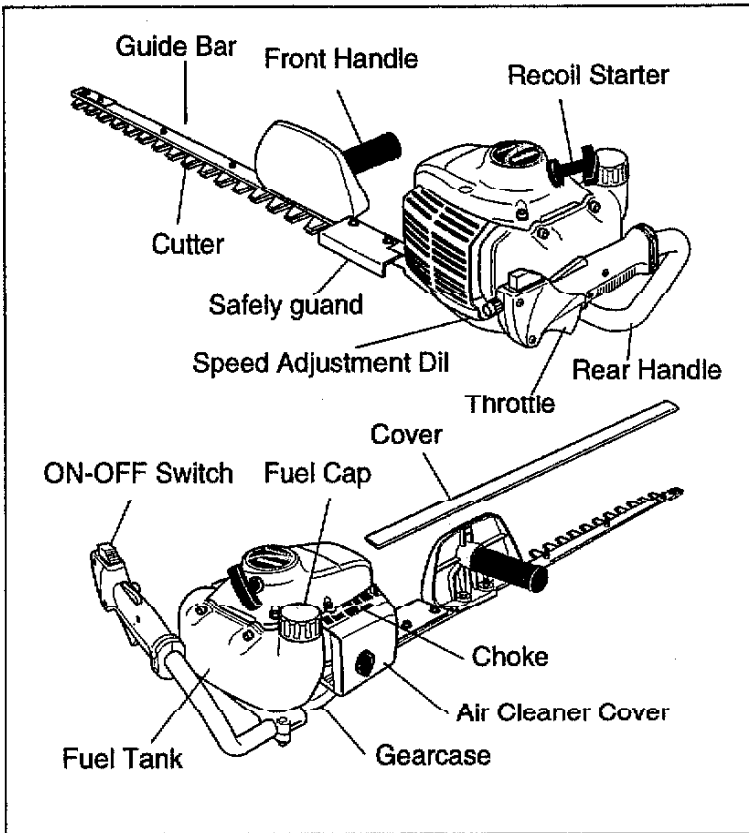

Using the accompanying illustrations as a guide, familiarize yourself with your machine and its various components. Understanding your machine helps ensure top performance, long service life, and safer operation.



WARNING! Do not make unauthorized modifications or alterations to this machine or to any of its components or accessories.

ENGLISH

DH230

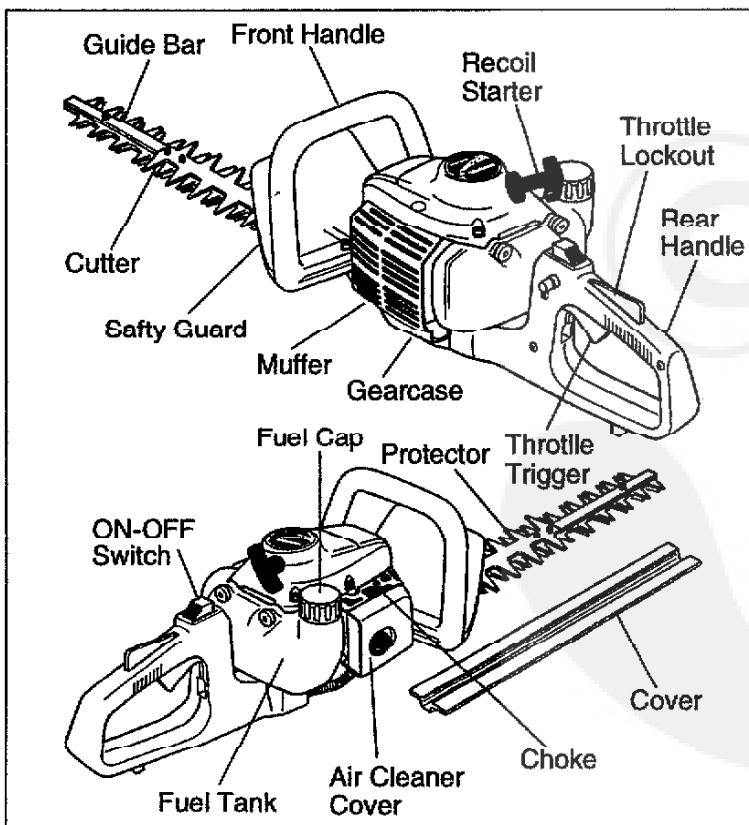

3 Specifications

Model Name		HT230-30	DH230-24
Engine Model	SHT230		
Engine Type	2-cycle, horizontal-cylinder, air-cooled		
Displacement	22.5 cc		
Bore × Stroke	32 mm × 28 mm		
rpm at Idle	3,000 rpm		
Maximum rpm	11,500 rpm		
rpm at Max Power Output	8,000 rpm		
Maximum Power Output	1.1 hp / 0.8kW		
Ignition	Fully electronic, transistor-controlled		
Spark Plug	NGK, BMR6A		
Starting Method	Recoil		
Stopping Method	Slide switch		
Air Cleaner Type	Semi-wet		
Fuel/Oil Ratio	25 : 1		
Fuel Tank Capacity	0.6 liter		
Carburetor Type	Wolbro, WYJ		
Dry Weight		5.6 kg	5.7 kg
Dimensions		990 × 210 × 210 mm	1,080 × 250 × 210 mm
Sound Pressure Level*	Idling	74.7 dB (A)	
	Racing	98.2 dB (A)	
Sound Power Level*	Idling	83.8 dB (A)	
	Racing	105.7 dB (A)	
Vibration Level*	Idling [left/right]	3.7/4.6 m/s ²	3.1/3.8 m/s ²
	Racing [left/right]	6.8/7.3 m/s ²	7.6/11.5 m/s ²

* Sound Pressure Level: in accordance with ISO 11201

* Sound Power Level: in accordance with ISO 3744

* Vibration Level: in accordance with EN 28662-1

Prior to Assembly

Before assembling this product, please make sure you have all the components required for a complete unit:

- Engine assembly (powerhead)
- Cutter and gearcase assembly
- Rear handle
- Front handle
- Bolt package
- Tool kit including, allen wrenches, screwdriver, combination spark plug/13mm wrench, 8 × 10mm wrench (HT230 only).

Carefully inspect all components for damage.

IMPORTANT!

The terms “left,” “left-hand,” and “LH”; “right,” “right-hand,” and “RH”; “front” and “rear” refer to directions as viewed by the operator during normal operation of this product.



4 Assembly



WARNING!

Incorrect assembly could expose the operator to serious injury! Read and follow assembly instructions carefully.

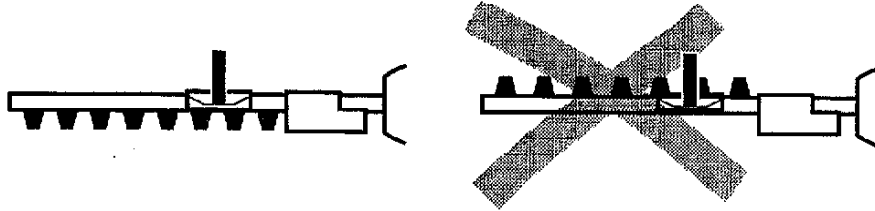

HT230

(1) Attaching the Rear Handle to the Gearcase

- ① Temporarily remove the 5mm × 12mm index bolt.
- ② Loosen, but do not remove, the 5mm × 25mm clamp screw, and verify that the D-washer (shim) is oriented as shown.
- ③ Position the rear handle assembly as shown. Starting from the rear of the trimmer, push the throttle cable, ignition wire, and ground wire through the handle mounting bracket.
- ④ Slide the rear handle into the handle mounting bracket until it bottoms. Use care to avoid pinching or otherwise damaging the wires and cable installed in Step ③.
- ⑤ Align the hole in the rear handle with the matching hole in the handle mounting bracket, and then install and firmly tighten the 5mm × 12mm index bolt.
- ⑥ Tighten the 5mm × 25mm clamp screw firmly.

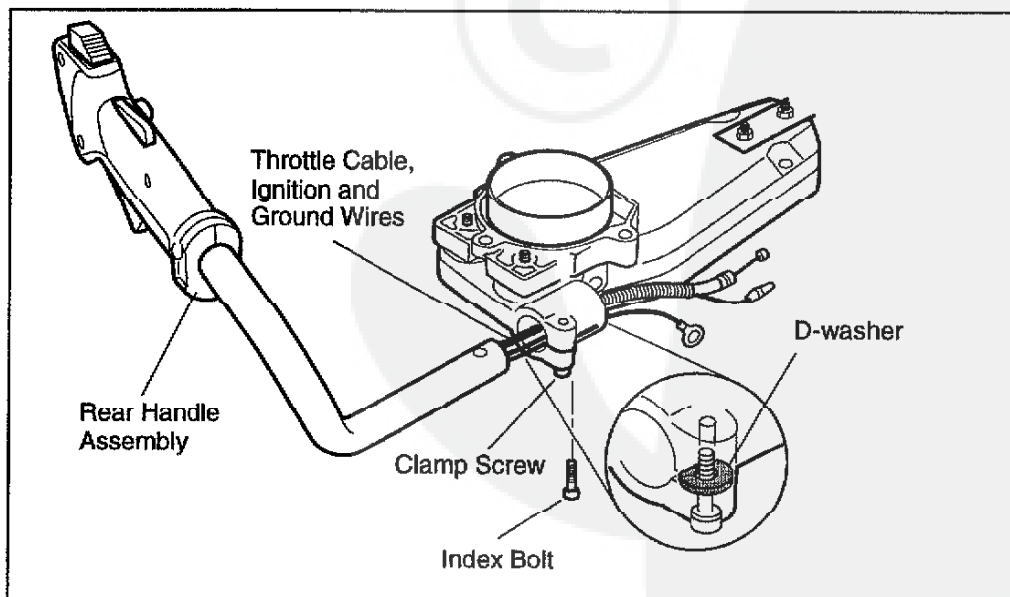

(2) Installing the Powerhead on the Gearcase

Orient the gearcase assembly to the powerhead as shown, and secure with the three 6mm × 16mm screws.

- ① Securely tighten Screws A and B.
- ② Push Screw C through the eye terminal in the throttle control ground wire, and then install and firmly tighten the screw to the powerhead.

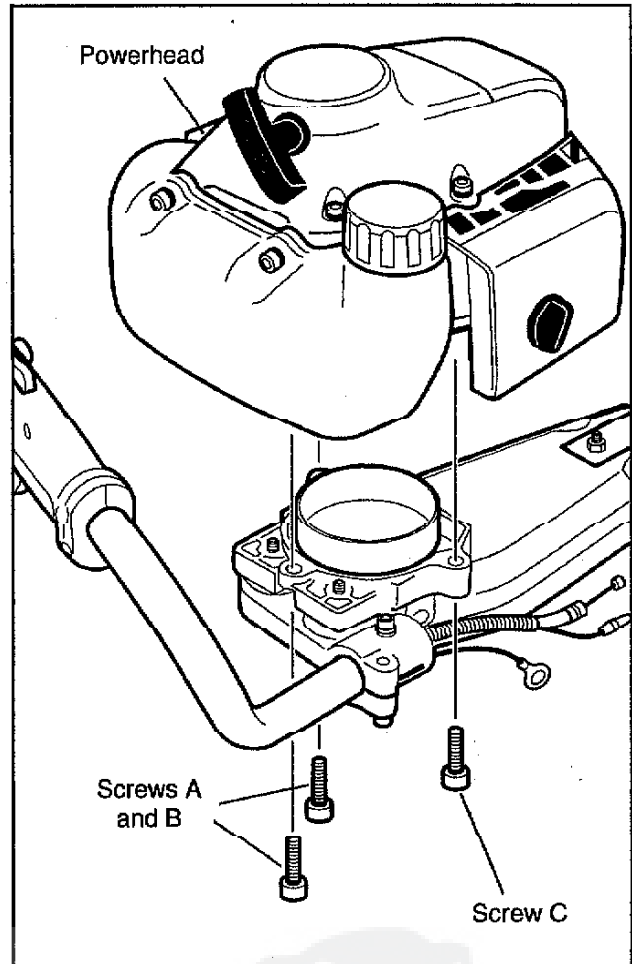

(3) Install the Front Handle

The front handle is installed over a 5mm stud on the guide bar, as well as a special 6mm × 30mm shoulder bolt assembly that is also used for guide bar adjustment. When installing the front handle, it is extremely important to maintain correct bar adjustment as described below:

- ① Install the 5mm flange nut over the stud on the guide bar, and then tighten the nut firmly.
- ② Hand-tighten the shoulder bolt, and then loosen the shoulder bolt 1/2-turn.
- ③ Install the 6mm washer and lock nut on the shoulder bolt but do not tighten the lock nut at this time.
- ④ While holding the shoulder bolt with a wrench, firmly tighten the lock nut.

IMPORTANT!

Improper shoulder bolt adjustment can shorten gearcase life drastically! Blade durability and cutting performance are affected by shoulder bolt adjustment.

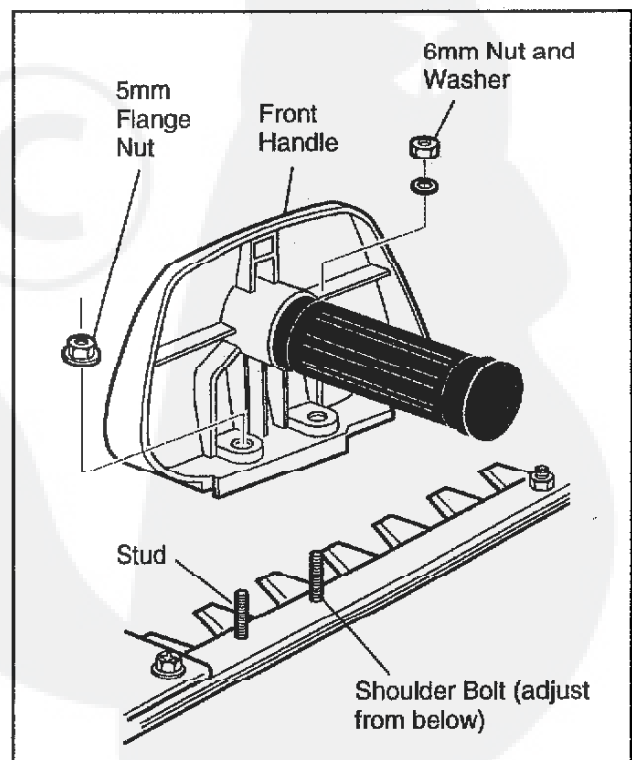

DH230

(1) Attaching the Rear Handle to the Gearcase Assembly

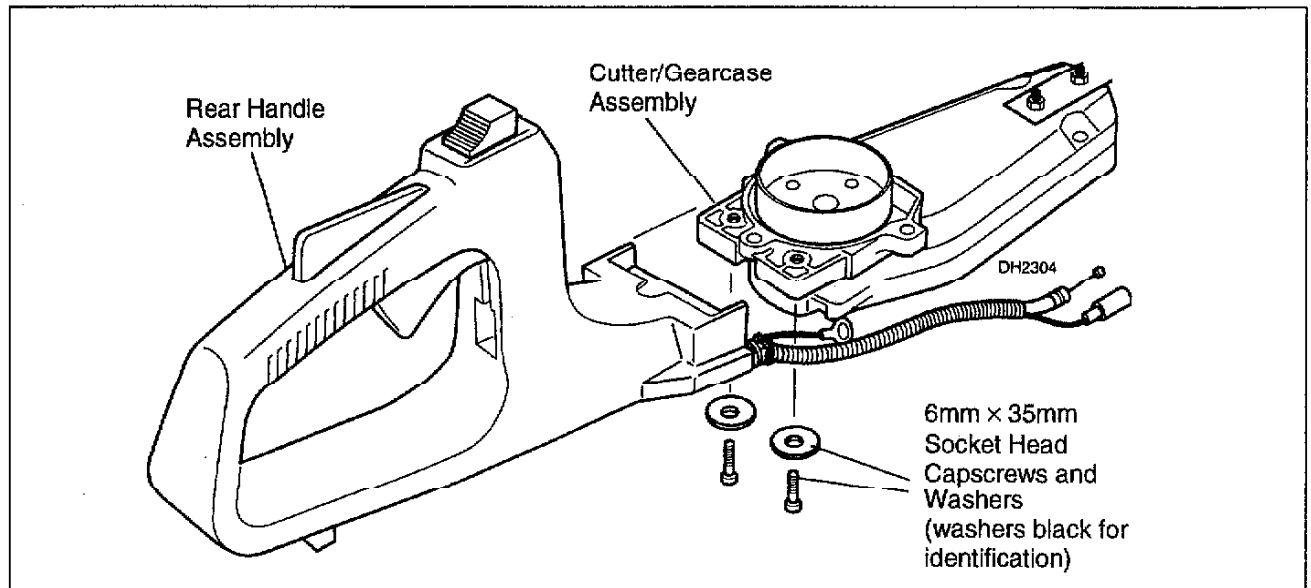

 **WARNING!**

■ Incorrect assembly could expose the operator to serious injury! Read and follow assembly instructions carefully.

■ Before attaching the rear handle, make sure the rear handle cushions are located correctly.

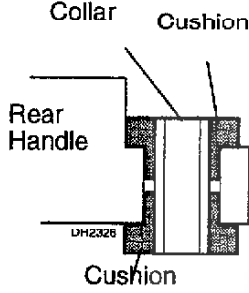

Collar

Cushion

Rear Handle

DH2328

Cushion

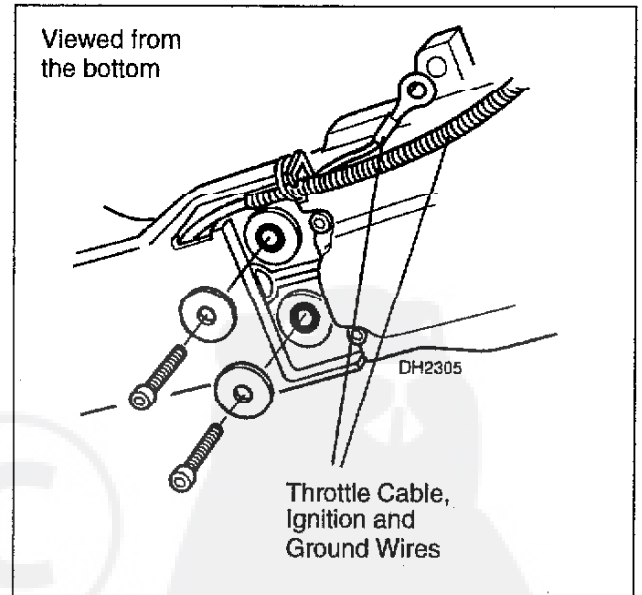

- ① Slide the rear handle onto the rear flange of the cutter / gearcase assembly. Make sure the throttle cable and ignition and ground wires do not bind during assembly.

- ② Make sure the mating holes between the rear handle and the gearcase are aligned, then secure the rear handle using two 6mm x 35mm socket head cap screws and washers.

IMPORTANT!

The washers used on the front handle and the rear handle are not the same. The washers for the rear handle are black for identification.

(2) Install the Front Handle

- ① Locate the front handle onto the catter / gearcase assembly as shown.
- ② Secure the handle using two 6mm × 35mm socket head capscrews and washers.

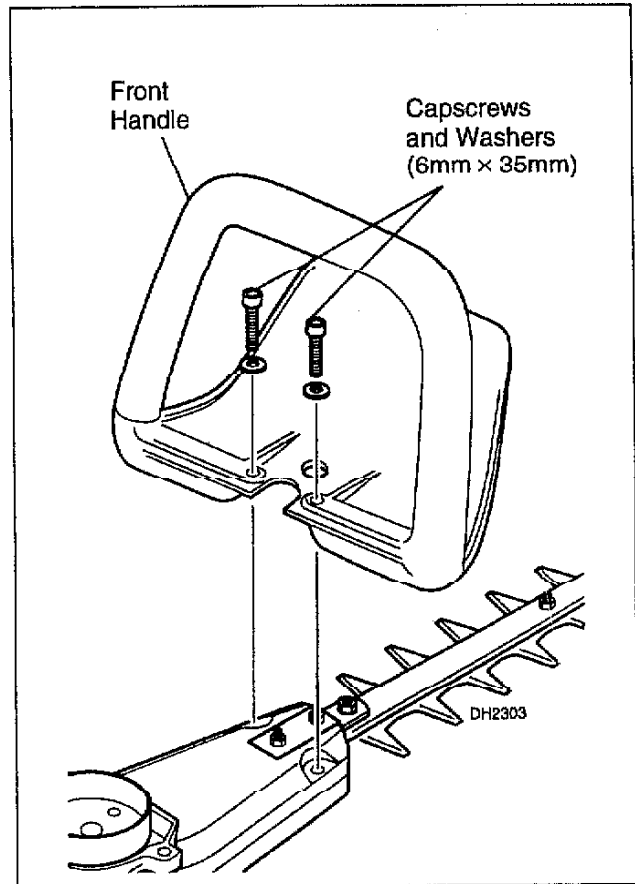

(3) Installing the Powerhead on the Gearcase

Orient the gearcase assembly and powerhead as shown and secure with the three 6mm × 16mm screws (Screws A, B, and C).

- ① Securely tighten Screws A and B.
- ② Push Screw C through the eye terminal in the throttle control ground wire (black), and then install and firmly tighten the screw to the powerhead.

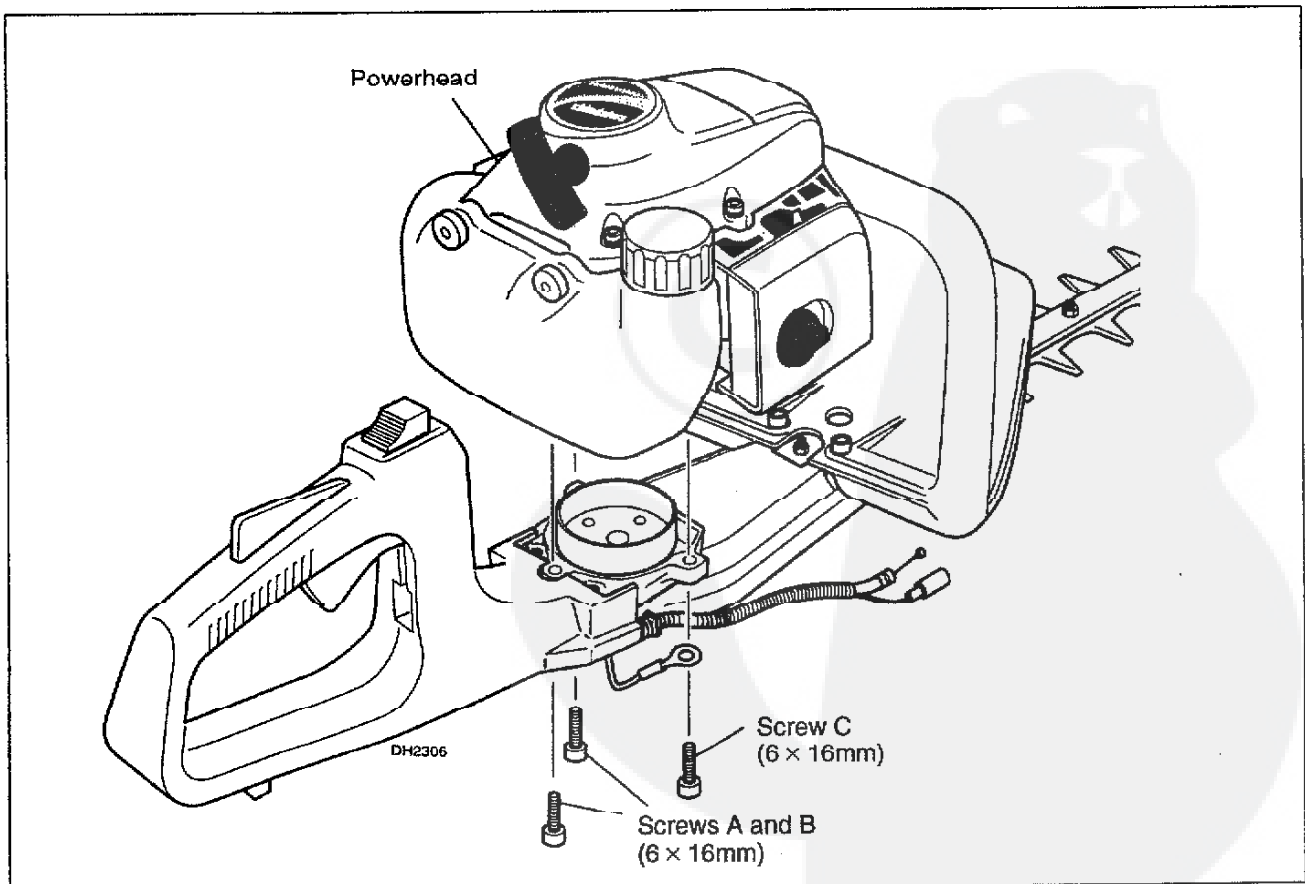

(4) Connecting, Adjusting the Throttle Cable and Connecting the Stop Switch

- ① Loosen the air cleaner cover retaining screw, and remove the air cleaner cover.
- ② Working from the bottom of the trimmer, push the throttle cable through the cable adjustment fitting. Rotate the carburetor throttle about 45°, and place the cable terminal in the throttle fitting.
- ③ Measure free travel at the end of the throttle lever. If necessary, turn the cable adjustment fitting in or out until throttle lever free travel is approximately 5—10mm (0.2—0.4”).
- ④ Firmly connect the two ignition wires as shown and tuck the wire behind the gasket.
- ⑤ Replace the air cleaner cover, and tighten the cover retaining screw securely.

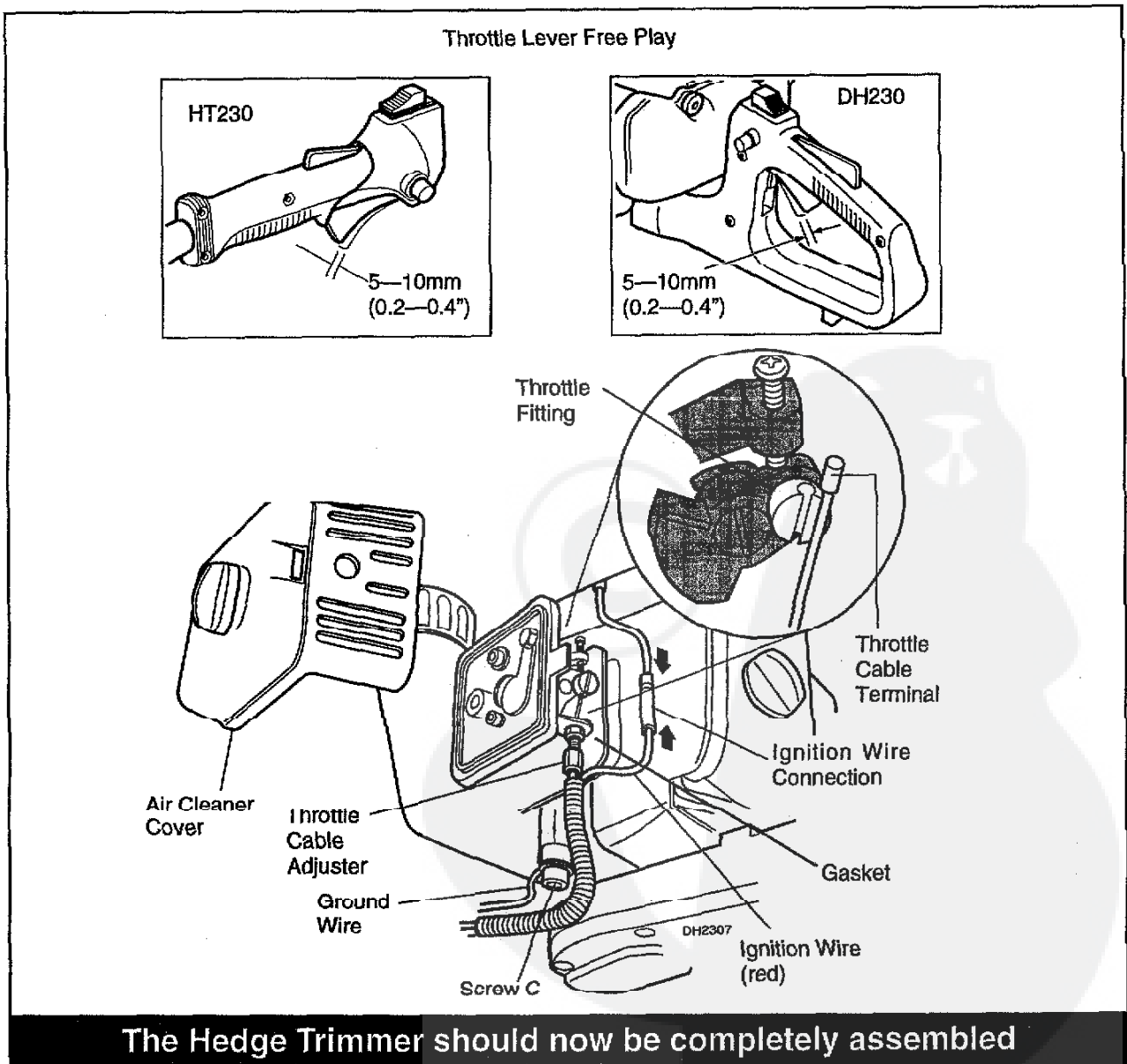

5 Mixing Fuel

- When mixing fuel, combine 2-cycle Engine Oil with gasoline at a ratio of 1 : 25.
- Use only fresh, clean unleaded gasoline with an octane rating of 87 or above.

CAUTION!

- This engine is certified to operate on a 25 : 1 mixture consisting of unleaded gasoline and 2-cycle mixing oil only.
- Some motor fuels contain alcohol as an oxygenate! Oxygenated fuels may cause increased operating temperatures. Under certain conditions, alcohol-based fuels may also reduce the lubricating qualities of some mixing oils.
- Never use any fuel containing more than 10% alcohol by volume! When an oxygenated fuel must be used, a fuel containing MTBE is to be preferred over an alcohol based fuel.
- Generic oils and some outboard motor oils may not be intended for use in high-performance air cooled 2-cycle engines, and should never be used in your Shindaiwa trimmer!
- Mix only enough fuel for your immediate needs! If fuel must be stored longer than 30 days, it should first be treated with a stabilizer such as StaBil™.

6 Filling the Fuel Tank

- (1) Place the machine on the ground or on a flat surface.
- (2) Clear any dirt or other debris from around the fuel filler cap.
- (3) Remove the fuel cap slowly, and fill the fuel tank with clean, fresh fuel mixture.
- (4) Replace and firmly tighten the fuel cap.



WARNING!

Minimize the risk of fire!

- Handle fuel with extreme care since it is highly flammable!
- Always allow the machine to cool before refueling!
- Wipe all spilled fuel and move the machine at least 10 feet (3 meters) from the fueling point before restarting!
- Never smoke or light any fires near the machine or fuels!
- Never place any flammable material near the engine muffler!
- Never operate the machine without the muffler.
- Do not inhale fuel fumes as they are toxic!

7 Starting Procedure

(1) Control Positions (Cold Engine)

- ① Move the ignition stop switch to the right (towards the grip) to the "T" or ON position.

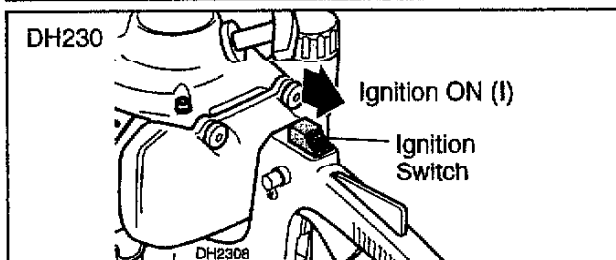
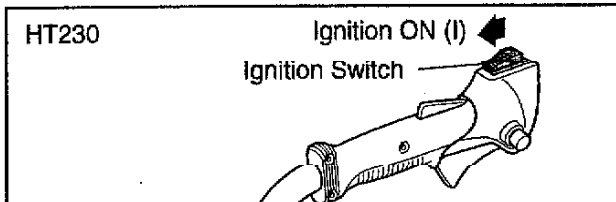

- ② Set the throttle trigger to the "fast idle" position by performing the following:

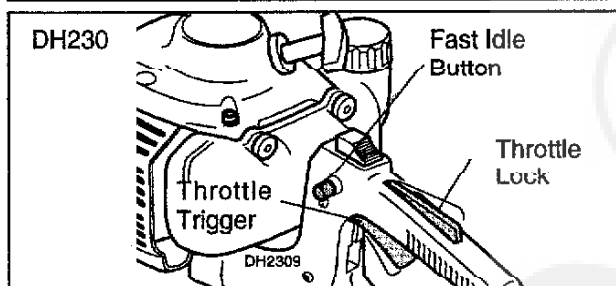
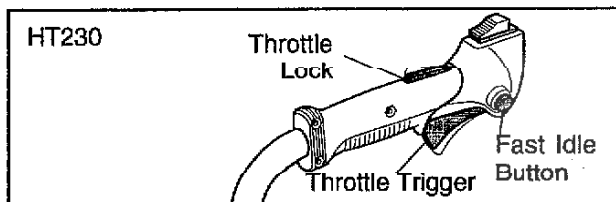

- a. Depress and hold the throttle lock, and then squeeze the throttle trigger.
- b. Depress and hold the "fast idle" button.
- c. While depressing the fast idle button, release the throttle lock and throttle trigger.

- ③ Prime the carburetor by repeatedly depressing the carburetor primer bulb until clear fuel can be seen flowing through the transparent primer bulb.

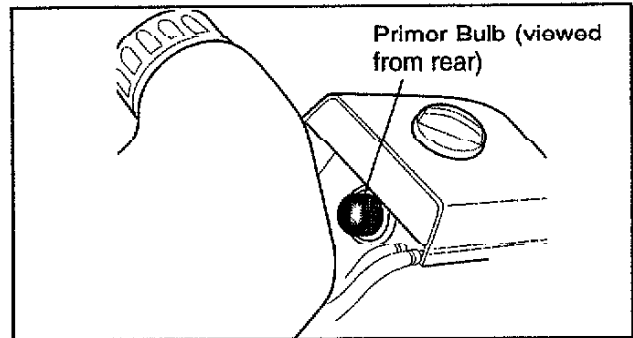

- ④ Choke the engine by moving the choke lever *forward* to the "closed" position (|/|).

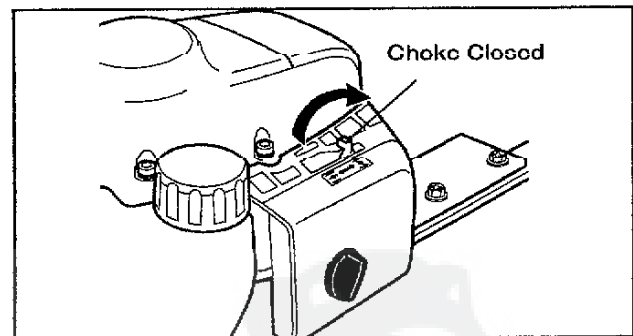

WARNING!
KEEP CLEAR OF THE CUTTING ATTACHMENT DURING STARTING OPERATIONS! THE CUTTERS MAY MOVE WHEN THE ENGINE IS STARTED!

- Place the trimmer on the ground during all starting operations.
- Make sure you have a secure footing, and keep a firm grip on the machine as well.
- Keep all bystanders and pets well clear of the trimmer during starting operations.

(2) Control Positions (Hot Engine)

- ① Move the ignition stop switch ON to the "I" position.
- ② Set the throttle lever to the fast idle position as in Step (2) (previous page).
- ③ Move the choke lever *back* (rearward) to the "open" position.

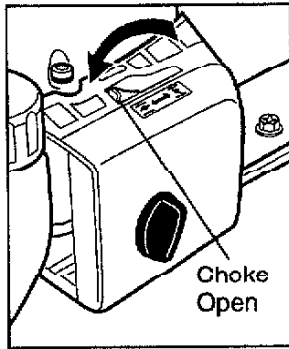

(4) When the engine starts or fires—

- ① Open the choke by moving the choke lever *backward* (toward the fuel tank).
- ② If the engine did not continue to run, repeat the appropriate cranking procedures for a cold or warm engine.
- ③ When the engine starts, clear excess fuel from the combustion chamber by accelerating the engine several times with the throttle lever.

(3) Cranking the Engine

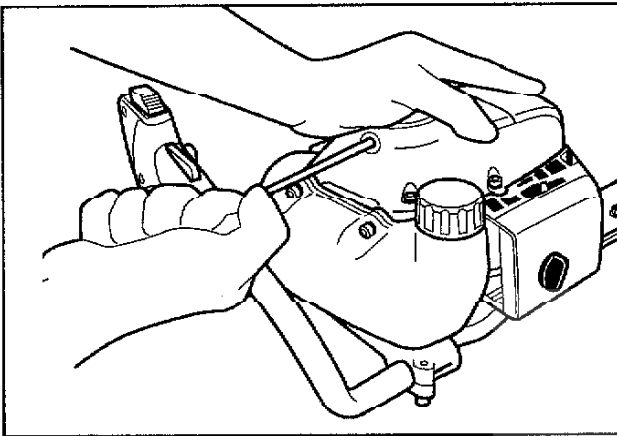

- ① Place the machine on the ground. Grip the engine cover with your left hand and the starter handle with your right hand (shown).
- ② Pull the starter handle slowly toward you until you feel the starter mechanism engage.
- ③ Start the trimmer by pulling the starting handle rapidly outward.

WARNING!
The cutting attachment will move when the engine accelerates!

- ④ Operating the throttle will automatically disengage the fast idle setting.

(5) If the engine does not start—

- Repeat the appropriate starting procedure for a cold or warm engine.
- If the engine still fails to start, use the procedures for "Starting a flooded engine." below.

IMPORTANT!

Engine ignition is controlled by a two-position on-off switch mounted on the throttle body. This switch is typically labeled "I" for ON and "O" for OFF.

CAUTION!

The recoil starter can be easily damaged by abuse!

- Always engage the starter before attempting to crank the engine.
- Never pull the starter cord to its full length.
- Always rewind the starter cord slowly.

(6) Starting a Flooded Engine



WARNING!

Burn danger from hot engine! Allow engine to cool before removing cylinder cover.

- ① Disconnect the spark plug lead, and then use the spark plug wrench to loosen and remove the spark plug.
- ② If the spark plug is fouled or is soaked with fuel, clean or replace the plug as necessary. For spark plug specifications and gapping procedure, see page 19.
- ③ With the spark plug removed, crank the engine several times to clear excess fuel from the combustion chamber.

- ④ Replace the spark plug and tighten it firmly with the spark plug wrench. If a torque wrench is available, torque the spark plug to 170—190 kg/cm (148—165 inch-pounds).
- ⑤ Replace the cylinder cover.

CAUTION!

Incorrect spark plug installation can damage the engine!

- ⑥ Repeat the starting procedures for a warm engine.
- ⑦ If the engine still fails to start or fire, refer to the troubleshooting chart at the end of this manual.

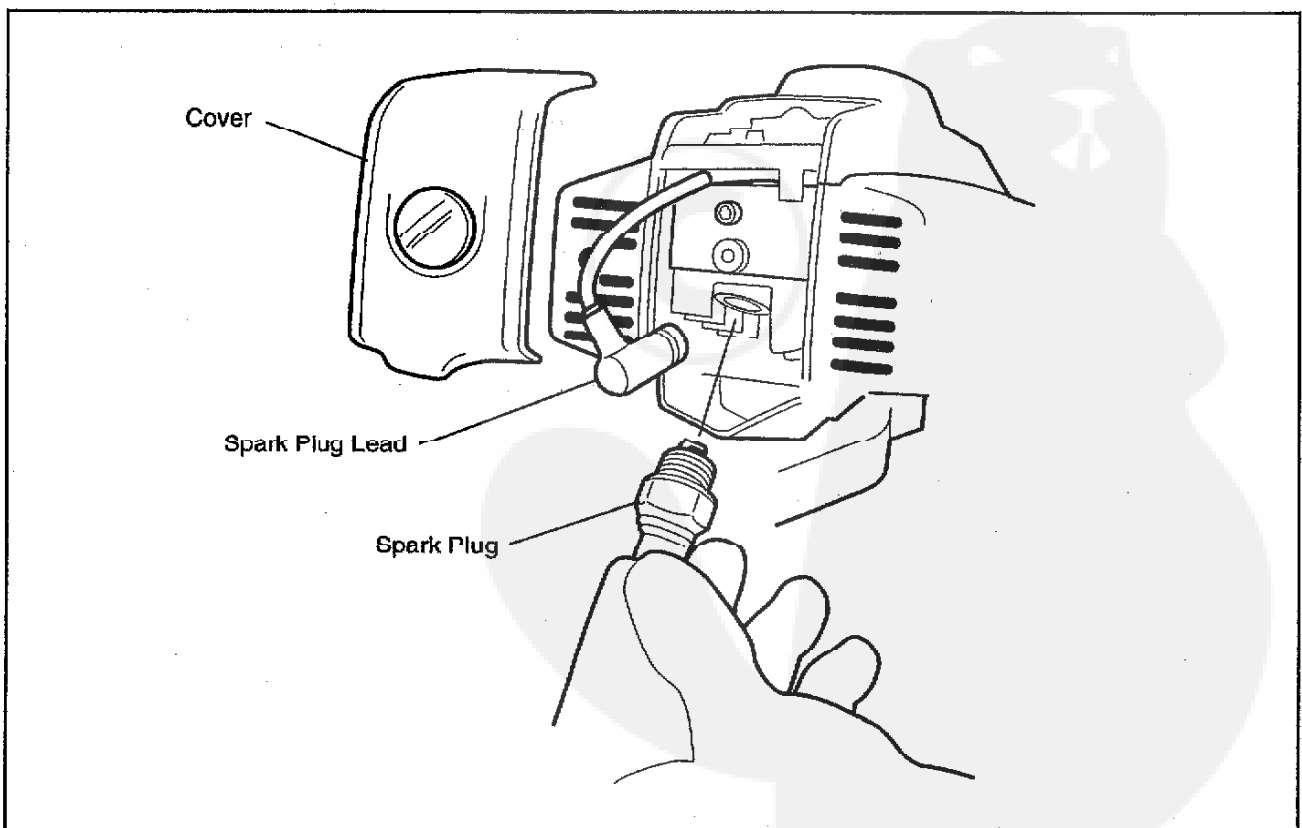

8 Adjusting Engine Idle

The engine **must** return to idle speed whenever the throttle lever is released. Idle speed is adjustable, and **must** be set low enough to permit the engine clutch to disengage the cutters.

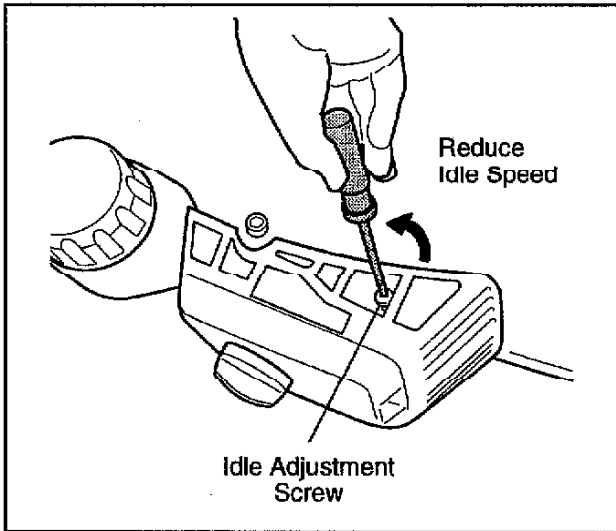

Idle Speed Adjustment

- (1) Start the engine, and then allow it to idle 2—3 minutes until warm.
- (2) If the cutters move when the engine is at idle, reduce idle speed by turning the idle adjustment screw counterclockwise.
- (3) If a tachometer is available, the engine idle speed should be final-adjusted to 2750 ~ 3000 rpm.
- (4) Carburetor fuel mixture adjustments are preset at the factory and cannot be serviced in the field.

WARNING!



The cutters must **NEVER** engage at engine idle speeds! If the idle speed cannot be adjusted by the above procedure, return the trimmer to your dealer for inspection.

9 Stopping the Engine

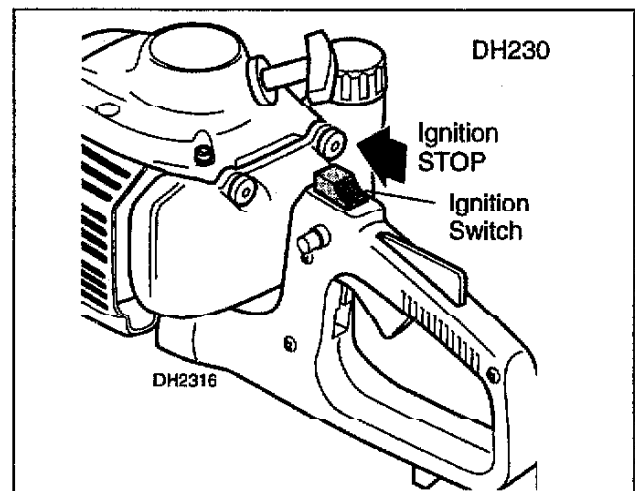
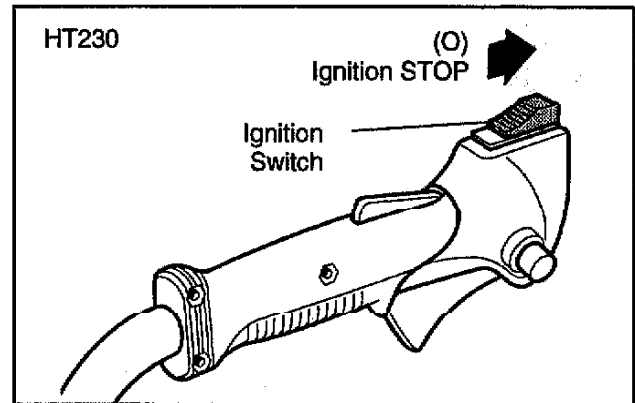

- (1) Cool the engine by allowing it to idle for 2—3 minutes.
- (2) Move the ignition switch to the "0" or STOP position.

10 Operation

- (1) Squeezing the throttle increases engine speed, causing the clutch to engage and operate the cutters.
- (2) Releasing the throttle decreases engine speed, causing the cutters to slow, and then stop altogether as the clutch disengages.
- (3) Use a sweeping motion when cutting, and vary throttle settings often.
- (4) Avoid cutting material larger than 13mm (1/2 inch) in diameter.

**WARNING!**

Never attempt to cut any material other than hedges and shrubs. The trimmer should not be used for any other purpose.

**WARNING!**

Know how to stop the machine quickly in an emergency.

(5) Speed Adjustment Dial

Turning the maximum speed adjustment dial anti-clockwise decreases the engine speed when the throttle is fully squeezed. Adjust the maximum engine speed to suit your work. (The maximum speed adjustment dial is preset on its maximum speed position at the factory.)

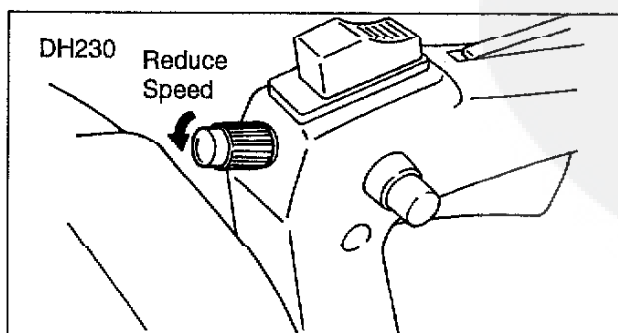
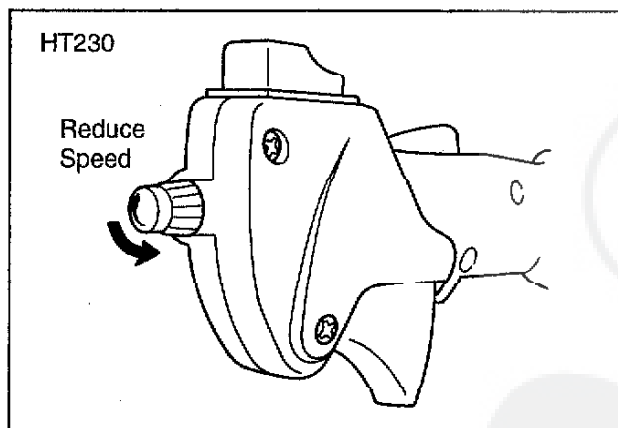
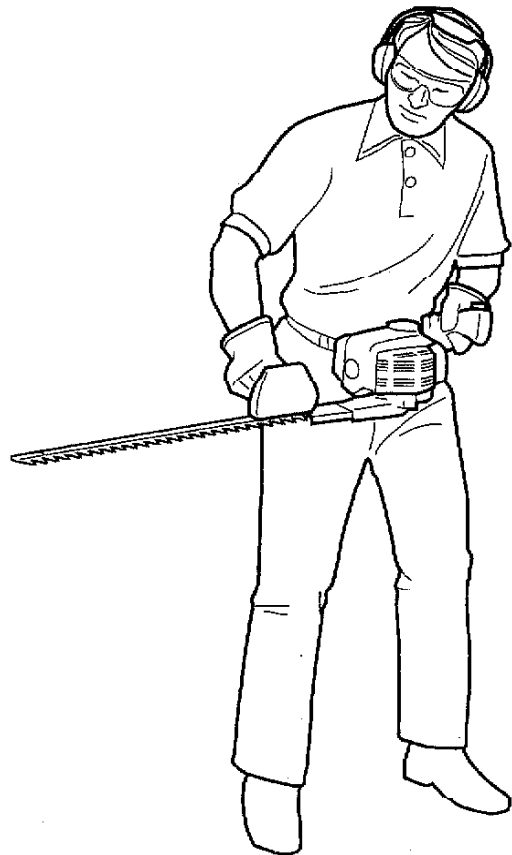
(6) General Safety Instructions**WORK SAFELY!**

- ① Always wear close-fitting. Gloves offer added protection and are strongly recommended. Do not wear clothing or jewelry that could get caught in machinery.
- ② Always wear eye, ear and hand protection while operating this machine!
- ③ Always stop the engine before removing branches or debris from the cutters! Never allow the cutters to contact buildings or other hard objects!
- ④ Always stop the engine and install the blade cover before moving to another work site, and maintain a firm footing while operating or carry the trimmer.

- ⑤ Never cut metal objects or wire with the blade.
- ⑥ Use extreme caution when operating near fences or electric wiring.
- ⑦ Avoid cutting large or extremely "woody" branches. Doing so can shorten cutter life, and may also damage the gearcase.
- ⑧ Never allow children to use the machine. Avoid operating near bystanders.
- ⑨ Always operate with both hands firmly gripping the machine.
- ⑩ Never operate this machine if the safety guard has been removed or damaged.
- ⑪ Never operate this machine at full throttle no-load rpm!
- ⑫ Avoid using or storing this machine in a wet environment. Water on the cutters may enter the gearcase and damage your machine.
- ⑬ Always keep proper footing and do not over reach. Maintain your balance at all times during operation.
- ⑭ Always ensure all handles and guards are fitted when using the machine. Never attempt to use an incomplete machine or one fitted with an unauthorized modification.
- ⑮ Always be sure of a safe and secure operating position especially when using steps or ladder while operating the trimmer.
- ⑯ Use of non-skid footwear is recommended.
- ⑰ Always be aware of your surroundings and stay alert for possible hazards that you may not hear due to the noise of the machine.

- (7) Trim the hedge swinging the blade as the illustration shows
At vertical cutting the Hedge Trimmer is used with circular pendulation, swinging up and down close to the hedge.

HT230



DH230



11 Maintenance and Adjustments

IMPORTANT!

Maintenance, replacement or repair of emission control devices and systems may be performed by any repair establishment or individual; however, warranty repairs must be performed by a dealer or service center authorized by Shin-Daiwa Kogyo Co., Ltd. The use of parts that are not equivalent in performance and durability to authorized parts may impair the effectiveness of the emission control system and may have a bearing on the outcome of a warranty claim.

(1) Gearcase Lubrication Schedule

① Every 20 Hours

Top off gearcase grease level by using a lever-type grease gun to force 1—2 strokes of high quality lithium-based grease through the gearcase grease fitting.

② Every 100 Hours

(or before long-term storage)

Remove the gearcase cover, and use solvent and a soft brush to remove all old grease from the gearcase. To refill, hand-pack the gearcase with approximately 40—50 grams of high quality lithium-based grease (50—70% of capacity). **DO NOT OVERFILL!**

CAUTION!

- Do not remove the conrods from the cutters. Conrod bearings can be lost or damaged if disturbed.
- Over-lubricating may cause the gearcase to run slower than normal, and may also cause leakage from excess grease.

VIEWED FROM THE BOTTOM

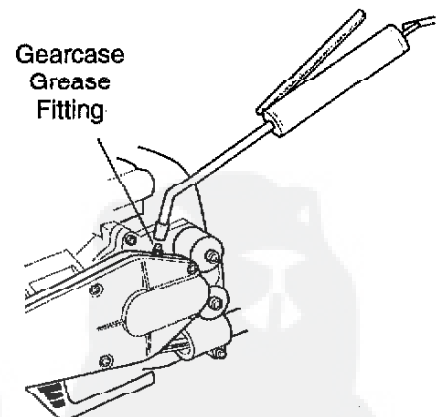

VIEWED FROM THE BOTTOM

DO NOT REMOVE CONRODS!

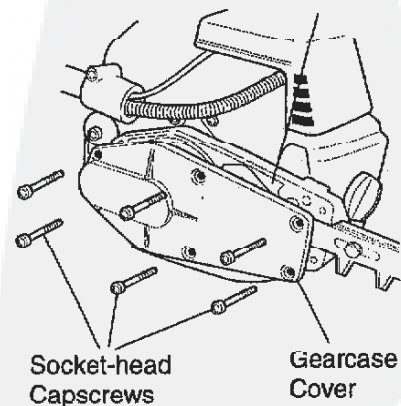



WARNING!

Accidental start-ups can cause severe injury! Before performing any maintenance on this machine or cleaning or checking this machine, stop the engine and disconnect the spark plug!

(2) Daily Maintenance/Inspection

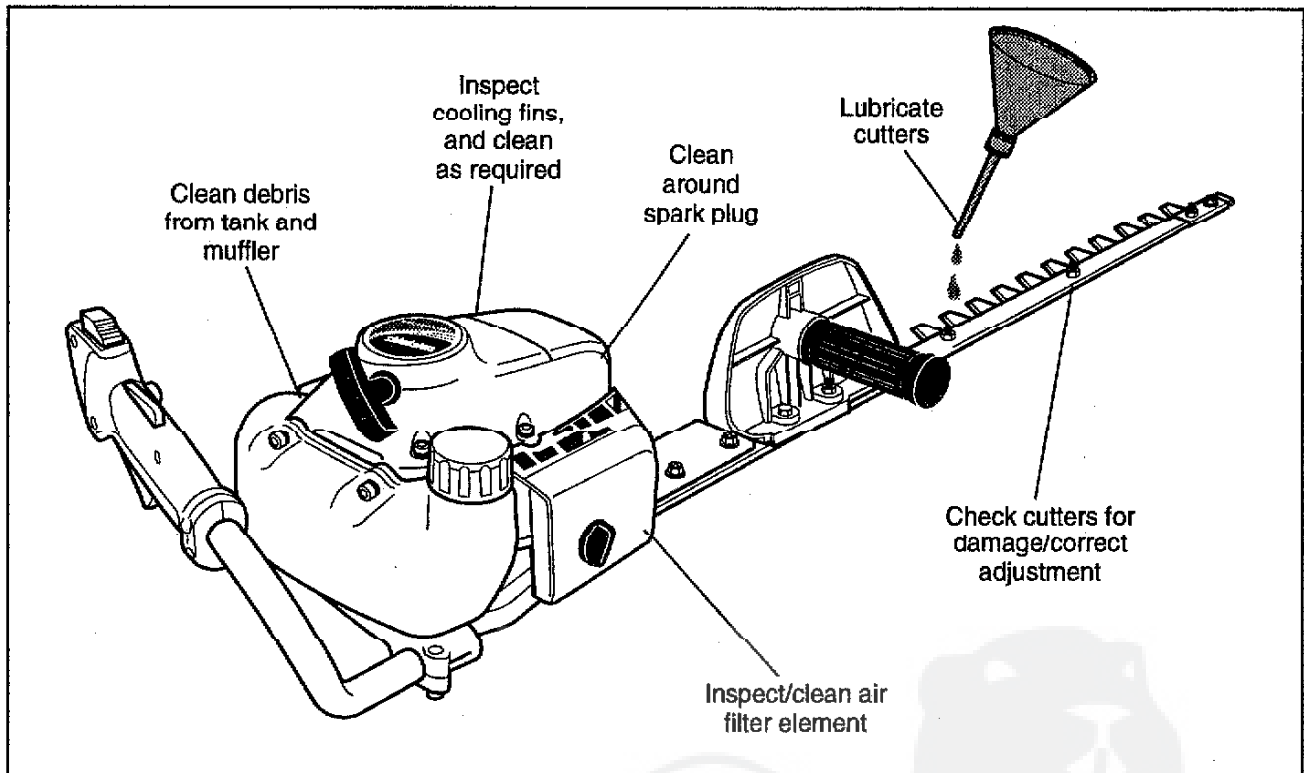

- ① Remove all grass clippings and dirt from the hedge trimmer.
 - Remove any compacted debris from around the fuel tank and/or muffler.
 - Inspect the engine cooling fins for clogging, and clean as necessary.
 - Clean beneath the cylinder cover and around the spark plug.
 - Inspect the air filter element for clogging, clean as necessary.
- ② Check for loose, damaged, or missing components, and repair as necessary.
- ③ Lubricate the cutters with oil before use, and after refueling.
- ④ Check the cutters for damage or improper adjustment, and adjust or replace as necessary.



WARNING!

To reduce fire hazard, keep the engine and muffler free of debris, leaves, or excessive grease.

(3) Every 50 hours (more often in dusty or extreme conditions)

- ① Remove the cylinder cover, and clean any grass and debris from the cylinder fins.

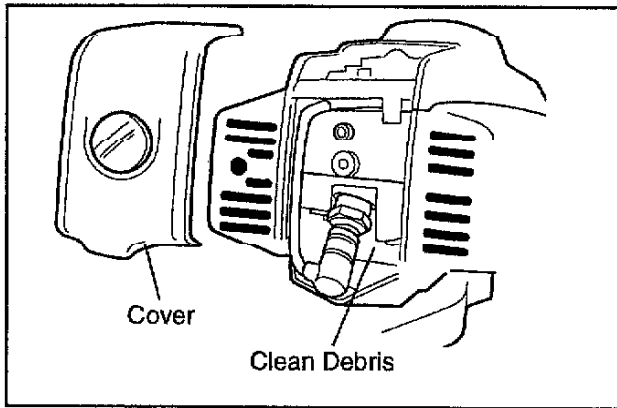

- ② Remove and inspect the spark plug. Replace any damaged or worn spark plug with a new NGK BMR6A

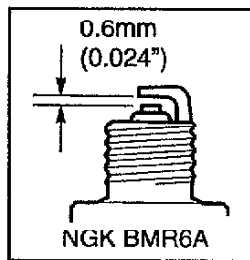

or equivalent. Adjust spark plug gap to 0.6mm (0.024 inch) and reinstall. If a torque wrench is available, torque the plug to 170—190 kg/cm.

- ③ Remove the air cleaner element, and wash the element in clean, neutral solvent or warm soapy water. Rinse the element thoroughly, and then squeeze dry before reassembly.

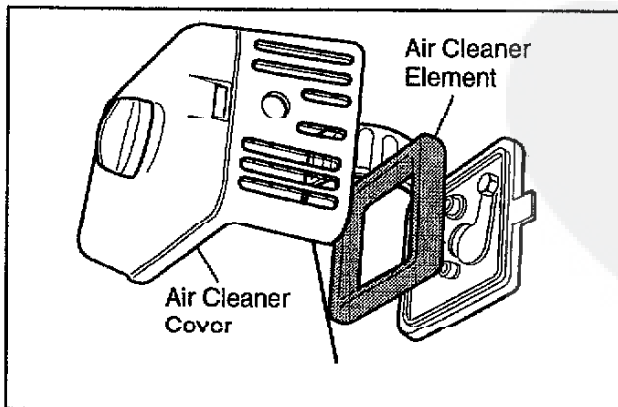

- ④ Check the cutters for damage, improper adjustment, or signs of excess wear, and adjust or replace as required.

(4) How to Adjust the Cutter Shoulder Bolts

- ① Loosen all cutter locknuts.
- ② Tighten each cutter shoulder bolt firmly, and then loosen the shoulder bolts 1/4 to 1/2 turn.
- ③ Working from the powerhead, lock each bolt in place by firmly tightening its locknut while preventing the shoulder bolt from turning.

When shoulder bolt adjustment is correct, there should be a gap of 0.25—0.50mm between cutters and the flat washer beneath each bolt head should turn freely.

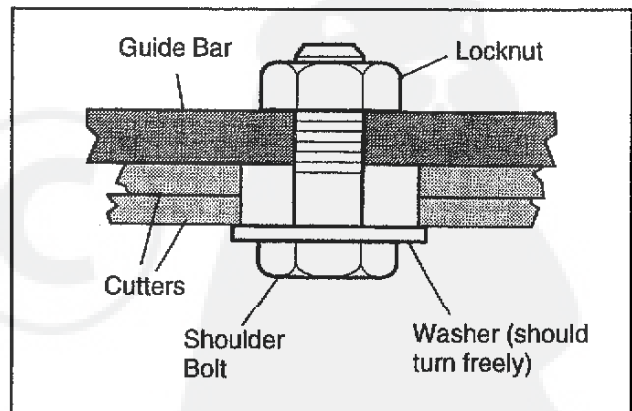

WARNING!

Do not operate the trimmer with a damaged or excessively worn cutting device. Faulty blades can increase the risk of accidents.

12 Long Term Storage

- Thoroughly clean the exterior of the machine.
- Remove all clippings and other debris from the cylinder fins and other components (as previously described under Daily Maintenance).
- Drain all unused fuel from the fuel tank, and then clear the carburetor and fuel lines by running the trimmer until it stops from lack of fuel.
- Remove the spark plug, and pour about 7 gram of oil into the cylinder through the spark plug hole. Before reinstalling the spark plug, slowly pull the recoil starter 2—3 times to distribute the oil over the cylinder wall.
- Service the air cleaner element as previously described under Daily Maintenance.
- Repair or replace any damaged components as required, and then store the machine in a clean, dry, dust-free area.

CAUTION!

Never store this machine with any fuel remaining in the tank, fuel lines or carburetor! Your Shindaiwa warranty does not include coverage for damage caused by stale or contaminated fuels.

13 Troubleshooting Guide



WARNING!

Do not attempt to repair the machine unless you are qualified to do so.

ENGINE DOES NOT START

What To Check	Possible Cause	Remedy
Does the engine crank? YES	NO Faulty recoil starter. Fluid in the crankcase. Internal damage.	Return trimmer to the dealer.
Good compression? YES	NO Loose spark plug. Excess wear on cylinder, piston, rings.	Tighten and re-test. Return trimmer to the dealer.
Does the tank contain fresh fuel of the proper grade? YES	NO Re-fill with fresh fuel of the correct mixture (2-cycle Engine Oil and gasoline, 1 : 25 ratio.)	Re-start
Is fuel visible and moving in the return line when priming? YES	NO Check for clogged fuel filter and/or vent. Clean as required.	Re-start.
Is there spark at the spark plug wire terminal? YES	NO The ignition switch OFF ("0"). Faulty ignition ground. Faulty ignition unit.	Move switch to ON ("I") and re-start. Return trimmer to the dealer.
Check the spark plug...	If the plug is wet, excess fuel may be in the cylinder. The plug may be fouled or improperly gapped. The plug may be damaged internally or is the wrong size.	Crank the engine with the plug removed, replace the plug, and re-start. Clean and re-gap the plug to 0.6mm (0.024 inch). Re-start. Replace the plug with an NGK BMR6A. Re-start.

Troubleshooting Guide (continued)

LOW POWER OUTPUT

What To Check	Possible Cause	Remedy
Is the engine overheating?	Operator is overworking the machine.	Cut at a slower rate.
	Carburetor mixture is too lean.	Return trimmer to the dealer.
	Improper fuel ratio.	Re-fill with fresh fuel of the correct mixture. (2-cycle Engine Oil and gasoline, 1 : 25 ratio.)
	Fan, fan cover, cylinder fins dirty or damaged.	Clean, repair, or replace as necessary.
	Carbon deposits on the piston or in the muffler.	Decarbonize.
Engine is rough at all speeds. May also have black smoke and/or unburned fuel at the exhaust.	Clogged air filter.	Service the filter.
	Loose or damaged spark plug.	Tighten or replace.
	Air leakage or clogged fuel line.	Repair or replace filter and/or fuel line.
	Water in the fuel.	Replace the fuel.
	Piston seizure.	Return trimmer to the dealer.
	Faulty carburetor and/or diaphragm.	Return trimmer to the dealer.
Engine is knocking.	Overheating condition.	See above.
	Improper fuel.	Check fuel octane rating; check for presence of alcohol in the fuel. Refuel as necessary.
	Carbon deposits in the combustion chamber.	Decarbonize.

Troubleshooting Guide (continued)

ADDITIONAL PROBLEMS

Symptom	Possible Cause	Remedy
Poor acceleration.	Clogged air filter.	Clean the air filter.
	Clogged fuel filter.	Replace the fuel filter.
	Carburetor mixture too lean.	Return trimmer to the dealer.
	Idle speed set too low.	Adjust: 2750 — 3000 RPM
Engine stops abruptly.	Switch turned off.	Reset the switch and re-start.
	Fuel tank empty.	Refuel.
	Clogged fuel filter.	Replace filter.
	Water in the fuel.	Drain; replace with clean fuel.
	Shorted spark plug or loose terminal.	Clean and replace spark plug, tighten the terminal.
	Ignition failure.	Replace the ignition unit.
Piston seizure.	Return unit to the dealer.	
Engine difficult to shut off.	Ground (stop) wire is disconnected, or switch is defective.	Test and replace as required.
	Overheating due to incorrect spark plug.	Clean and regap to 0.6 mm (0.024"). Correct plug: NGK BMR6A.
	Overheated engine.	Idle engine until cool.
Cutters move at engine idle.	Engine idle too high.	Set idle: 2750 — 3000 RPM
	Broken clutch spring or worn clutch spring boss.	Replace spring/shoes as required, check idle speed.
Excessive vibration	Warped or damaged guide bar or cutters.	Inspect and replace as required.
	Damaged gearcase or cam case.	Return trimmer to the dealer.
	Shoulder bolts/cutters worn or out of adjustment.	Adjust or replace as required.

14 Declaration of Conformity

DECLARATION OF CONFORMITY

ENGLISH

We hereby declare that the Shindaiwa hedge trimmer,
Model HT230, DH230

meets the following respective requirements.

Council Directives:

89/336/EEC as amended

89/392/EEC as amended

Standard taken:

EN 292 parts 1 & 2

EN 774

SHIN-DAIWA KOGYO CO., LTD.

35 Shinujigami, Chiyoda-cho,
Yamagata-gun, Hiroshima 731-1597
JAPAN

TEL: 0826 72 6011

FAX: 0826 72 7005

M. Matsumoto
Vice President

