

# Operating Manual Hedge Trimmer



## Safety Alert Symbols

These symbols are used to alert you to instructions concerning your personal safety. Follow the instructions indicated by such symbols, since they illustrate important safety precautions.



The basic meaning is...ATTENTION! REMAIN ALERT!  
THIS CONCERNS YOUR PERSONAL SAFETY!  
Read the following information and remain highly alert to the possibility of personal injury or death!



Read the operating manual carefully.



Wear eye and ear protectors when using this machine.



It means...NEVER DO THIS!

## Safety Instructions

1. This machine has the potential to cause serious injuries. Please read the Operating Manual carefully and master all operations and correct procedures before operating this machine.

2. This machine is intended for trimming branches and stems. Never use this machine for any other purposes.

3. Clothing during operation (Select appropriate clothing)

- (1) Wear a long sleeved garment and long trousers.
- (2) Avoid jackets or trousers with flared cuffs, since they may get caught in the machine or in cut branches.
- (3) Do not wear any jewelry.
- (4) Wear a hat with a brim, safety glasses and ear protectors during operation.
- (5) Wear non-slip shoes with creepers. Do not wear sandals.
- (6) Wear thick and stout gloves.

4. Conditions for operators

- (1) If you are unfamiliar with the machine, or borrowing the machine, please familiarize yourself with received instructions concerning safe operation before starting to use.
- (2) Use by those in the following categories is forbidden:
  - [1] Mentally deranged persons
  - [2] Intoxicated persons
  - [3] Under-age minors
  - [4] Persons who cannot perform normal operation due to extreme fatigue, disease, the effects of medication or drugs and other reasons.



## 5. Beware of fire



- (1) Treat the fuel carefully, since it is extremely flammable. Never smoke near the fuel or place the machine near bonfires or heaters.
- (2) Never refuel the engine when it is still hot or running.
- (3) Never smoke while the engine is running or during re-fueling.
- (4) Before refilling with fuel, always stop the engine and allow to cool. Only refill when there is no sign of fire.
- (5) When refilling, be careful not to spill any fuel. If inadvertently spilled, wipe off thoroughly.
- (6) Do not situate the engine or muffler near twigs, withered grass or spilled oil.



## 6. Pre-operation precautions

- (1) Before starting, always check to make sure that there are no loose screws, and that all handles and protection devices have been mounted. Never operate unsafe machines or machines that have undergone non-professional remodeling.
- (2) Do not operate the machine if any blade is damaged or excessively abraded.



## 7. Start up precautions

- (1) Before starting the engine, confirm there is no one nearby.
- (2) Upon starting, ensure the cutting blades are facing in the opposite direction from you and that the machine is stable.

## 8. Operating precautions

- (1) Always grip the handlebar with both hands. Keep your legs slightly apart so that your weight is equally supported by both and maintain a stable posture.
- (2) Do not operate the machine if there are people, animals or children in particular in the vicinity.
- (3) If two or more machines are engaged, maintain a sufficient distance between them and remain continually aware of the location(s) of other machine(s).
- (4) During indoor operation or when starting the engine indoors, always open the windows for ventilation. Do not inhale the exhaust.
- (5) Operations in rainy conditions or soon after a rain require special caution due to the risk of slipping.
- (6) If grass or branches are caught in the cutting blades, stop the engine before removing them.
- (7) During operation or soon after stopping the engine, do not touch the engine or other heated parts.
- (8) Before implementing repair or adjustment, stop the engine and remove the spark plug cable from the spark plug.
- (9) Before suspending an operation or relocating equipment, always stop the engine and place a cover over the cutting blades.
- (10) Do not operate the machine on an unstable footing, such as on a ladder, steps or any other raised position.
- (11) Stop the engine immediately when the machine touches objects or in the event of any abnormal vibration. Remove the spark plug cable from the spark plug and inspect if there is any damage to the machine. In the event of any damage, please repair it before reusing.



## 9. Inspection and repair precautions

- (1) No repair by any unqualified persons is allowed.
- (2) During inspection, remove twigs, leaves and excess grease from the engine and muffler to reduce the risk of fire.
- (3) During storage or display, always place a cover over the cutting blades.



This manual shows the proper way to handle, operate and tune-up the machine. To use the machine safely and obtain the best results, be sure to read this manual carefully along with the handling instructions for the engine.



**YOU WILL NOTICE THIS MARK IN THIS MANUAL. IT IS INTENDED TO ALERT THE OPERATOR TO A SAFETY PRECAUTION TO BE FOLLOWED IN ORDER TO AVOID THE RISK OF POTENTIAL DAMAGE OR INJURY. PLEASE ENSURE YOU FULLY UNDERSTAND THE MARKED INSTRUCTIONS AND FOLLOW THEM TO GUARANTEE SAFETY.**

## CONTENTS

	Page		Page
1. Main functions .....	4	6. Pre-operation checks and tune-up .....	8
2. Specifications .....	4	7. Basic working techniques .....	8
3. Parts location and functions .....	5	8. Maintenance .....	9
4. Construction .....	5	9. Long term storage .....	10
5. Operation .....	6	10. Troubleshooting guide .....	10

## 1. Main Functions

- 1-1. Adjustable rear handle** ..... You can set the rear handle in five positions. (there is a step every 45 degrees.)
- 1-2. Throttle lever with brake** ..... The breaking system stops the blade automatically when you release the throttle lever.  
(Only for models with brake system)
- 1-3. Double insulation system** ..... Metal springs and plastic dumpers ease the vibration on your hands and arms.
- 1-4. Large transparent protector** ..... It widens your operational view for a safer working environment.



## 2. Specifications

Model		HTF600D		HTF750D	
Sound level (dB(A)) ISO 3744		100		100	
Vibration level (m/s <sup>2</sup> ) ISO 7916	Handle	Front	Rear	Front	Rear
	Idling	1.1	1.2	0.8	1.1
	Racing	2.1	5.5	2.3	2.6

### 2-1. Specifications

Dry weight (kg)	3.1	3.4
Overall length (mm)	600	750
Blade length (mm)	550	700
Tooth pitch (mm)	35	
Speed (mm/sec)	1001 (7000 rpm)	
Clutch	Automatic centrifugal clutch	
Gear ratio	1 : 4.08	
Drive	Two series cam-drive	
Lubrication	Grease	

### 2-2. Specification of engine

Model	TH23	TL201	TL23	TL26
Dry weight (kg)	2.1	2.2	2.5	2.6
Displacement (cc)	22.5	19.8	22.8	25.6
Output (Max.) (kW)	1.3	0.74	0.88	1.03
Fuel tank capacity (L)	0.5	0.45	0.5	0.6
Type	2 cycle-air cooled			
Carburetor	Diaphragm type			
Fuel	Gasoline/Oil Mix 25:1			



## 3. Parts Location and Functions

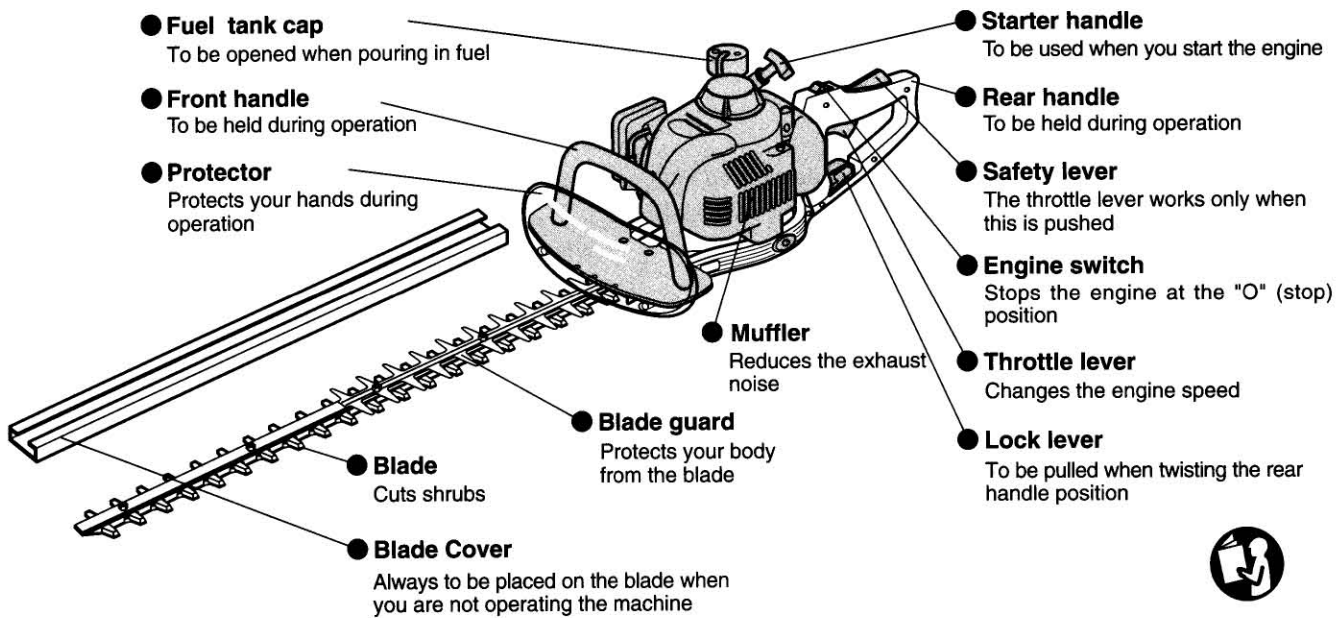

## 4. Construction

### 4-1. Accessories

Remove the machine and accessories from the package and check for the following items:

- (1) Accompanying tools ..... 1 set
- (2) Engine instruction manual ..... 1 copy
- (3) Hedge trimmer operating manual (this one) ..... 1 copy

### 4-2. Construction of machine

This machine is delivered in pre-assembled form.  
The picture on the right is only for reference purposes when checking the tightness of the screws.

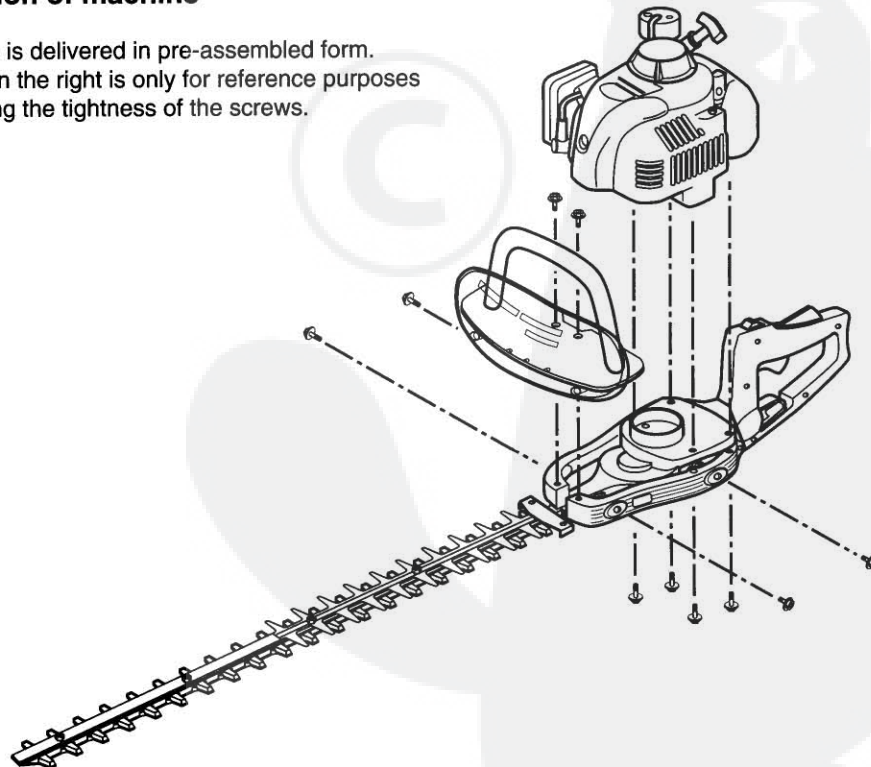



**WARNING!**  
ENSURE THAT ALL SCREWS ARE TIGHTENED AND THAT THE GRIPS AND PROTECTIVE DEVICE ARE ALL IN PLACE.

#### 4-3. Connection of cables

This machine is delivered in pre-assembled form.  
The picture on the right is for reference purposes during checking.

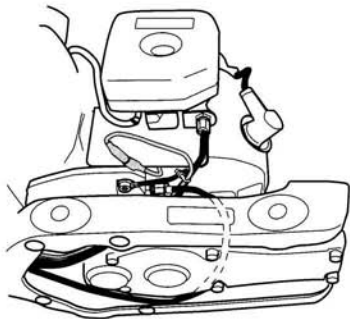

## 5. Operation

#### 5-1. Fuel

Use mixed fuel, mixed at a ratio of  
25 parts (gasoline) : 1 part (engine oil).  
Use proper engine oil for the two-cycle engine.

When using special oil sold by an engine manufacturer,  
read the instructions for the proper mixture ratio.



Engine oil for two-cycle engine

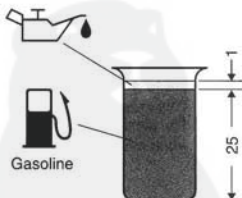

**WARNING!**  
**BEWARE OF FIRE!**  
THE FUEL IS EXTREMELY FLAMMABLE AND DANGEROUS!

#### 5-2. Starting

Move at least 3 meters away from the refueling site.  
Place the Hedge Trimmer on a clean area of ground, ensuring  
that the cutting teeth do not come into contact with the  
ground or any other objects.



### 5-2-1. Cold starting

When the engine is cold or has been switched off for more than 5 minutes or when fuel is added to the engine.

- (1) Push the engine switch to the "I" (start) position.
- (2) Rotate the start lever to the "START" position.
- (3) Gently push the primer pump repeatedly (7 to 10 times) until fuel enters the primer pump.
- (4) Hold the unit down firmly so you will not lose control while cranking the engine. If not held down properly, the engine could pull you off balance or swing the cutting blade into an obstruction or your own body.
- (5) Pull the starter handle slowly 10 to 15 cm, and check the location of the pressure.
- (6) Pull the starter handle strongly when a drag force can be felt and start the engine.
- (7) Please note that the start lever will revert to the "Run" position automatically when the throttle lever is operated to open the throttle slightly.  
Run the engine for approximately 2 or 3 minutes at moderate speed before applying full speed.

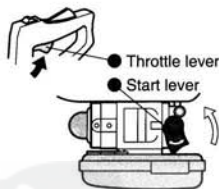
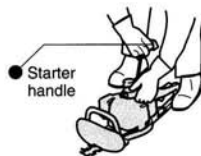
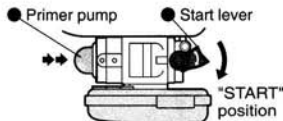

### 5-2-2. Hot starting

Restarting immediately after the engine has stopped

When restarting a hot engine, first attempt the above procedures: (1), (4), (5), and (6).

If the engine does not start, repeat the above steps (1)-(7).

- Attention!**
- [1] If the starter handle is pulled repeatedly when the start lever remains at the "START" position, the engine will not start easily due to excess fuel intake.
  - [2] In the case of excess fuel intake, remove the spark plug and pull the starter handle slowly to remove excess fuel. Also, dry the spark plug electrode.
  - [3] Do not pull out the starter rope to its full extent and do not allow the starter handle to be retracted without control, ensure that it is retracted slowly.

### 5-3. Stopping

- (1) Release the throttle lever completely.
- (2) Push the engine switch (on/off switch) to the "O" (stop) position, whereupon the engine rotation will slow down and the engine will stop.

● Throttle lever

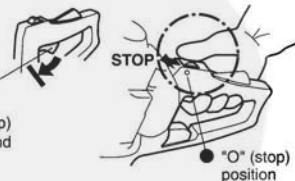

#### WARNING!

WHEN YOU RELEASE THE THROTTLE LEVER, THE CUTTING BLADES REQUIRE A FEW MOMENTS TO STOP COMPLETELY.



## 6. Pre-operation Checks and Tune-up

Never operate the machine without checking the following items!

**6-1. Pre-operation checks** ..... Ensure you can answer "Yes" to all of the following questions

- (1) Have you read through and understood the entire contents of the "Safety instructions" on pages 2 and 3 ?
- (2) Are the blades sharp enough?
- (3) Are all the parts and cables properly installed ?
- (4) Is there enough fuel in the fuel tank?



**WARNING!**  
BEFORE CHECKING, BE SURE TO STOP THE ENGINE.

**6-2. Checks on the engine start-up**

- (1) Do the blades remain still when the engine is started ?
- (2) Is there any unusual noise or looseness of parts ?
- (3) Does the engine speed increase when you pull the throttle lever ?
- (4) Does the brake work automatically when you release the throttle lever ?

**6-3. Tune-up**

Never operate the machine if the checks performed reveal any problems.

If the machine needs tuning-up, follow the procedure outlined in "8. Maintenance" on page 9.

If you do not understand the mechanism or construction of the machine, never attempt to adjust it, or you will risk damaging it.

## 7. Basic Working Techniques

**7-1. Adjusting the rear handle**

The rear handle can be set into five positions as desired.

To free it for positioning, pull the lock lever.

(See the illustrations on the right.)

The following operations cannot be performed for safety reasons.

- (1) Pulling the lock lever while the throttle lever is pulled.
- (2) Pulling the throttle lever while the lock lever is pulled.

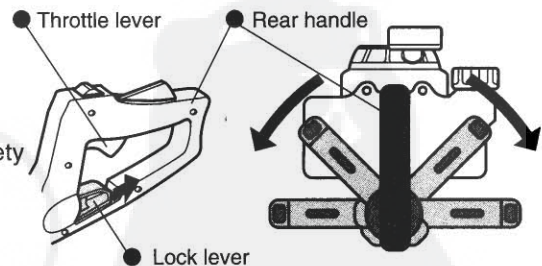

**Attention!** Always tilt the rear handle upwards during operation, regardless of the blades' position.



**WARNING!**  
BEFORE ADJUSTING THE HANDLE, BE SURE TO STOP THE ENGINE.

**7-2. Top trimming**

Grip the handles firmly with both hands, and keep the machine body horizontal.

Then, slightly incline the cutting blade in a cutting direction and trim the shrub while swaying as if drawing an arc.

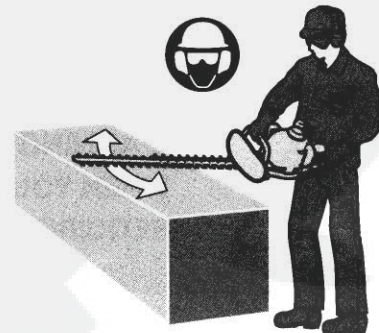



### 7-3. Side trimming

Keep the machine body vertical and trim the shrub upwards from the bottom, keeping the cutting blade as far from your body as possible.

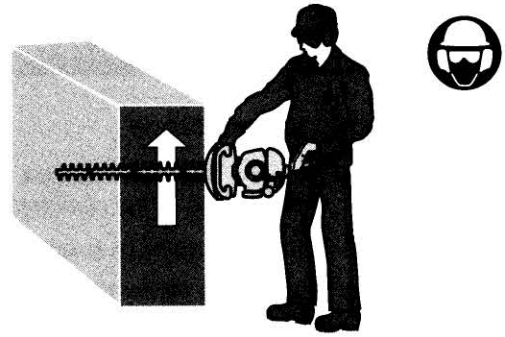

## 8. Maintenance

### 8-1. Adjustment of blades

The blades wear away with long term use. When you find the trimming performance has deteriorated compared to that with new blades, adjust them in the following ways:

- (1) Loosen nut ①.
- (2) Lightly tighten screw ② with the driver until it stops turning, and then screw it back between a quarter and half turn.
- (3) Tighten nut ①.
- (4) Lubricate the blades following the above adjustments.
- (5) Start the engine and operate the blades at the maximum engine speed for a minute or so.
- (6) Stop the engine and touch the blades with your hand. If they are warm enough for you to keep your hand on them, you have made the proper adjustments. However, if they remain too hot to touch, turn screw ② back a little further and repeat (5) to check if they are properly adjusted.

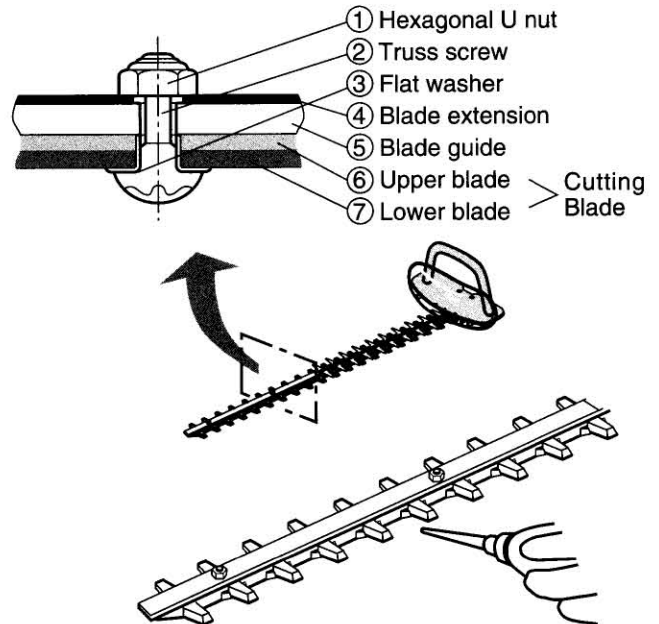

- Attention!**
- [1] Always stop the engine before making the adjustments.
  - [2] The blades have a slot around screw ②. In the event you find dust on the ends of the slots, please clean as required.
  - [3] Replace worn out cutting blades for new ones.



#### **WARNING!**

- DO NOT PERFORM ANY CUTTING BLADE ADJUSTMENT WITHOUT FIRST STOPPING THE ENGINE.
- HOLD THE MACHINE FIRMLY WHEN OPERATING.
- DO NOT OPERATE BAREHANDED.

### 8-2. Gear case

Once every 20 hours of use, inject a suitable amount of grease through a grease nipple installed in the gear case of the Hedge Trimmer.

### 8-3. Brake Adjustment

Proper maintenance is required in order to maintain long-term brake operation. When the brake does not work, please contact the dealer from which you purchased this machine.

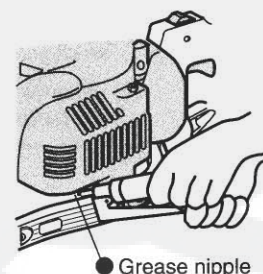

## 9. Long Term Storage

### 9-1. Long term storage

- (1) Drain the fuel from the tank, then start the engine and keep it running until it consumes all the remaining fuel in the carburetor and stops.
- (2) Remove the spark plug, and inject a small amount of engine oil through the spark plug hole.
- (3) Then pull the starter handle a few times to place a thin coat of oil on the cylinder.
- (4) Reinstall the spark plug when the piston has stopped at the very top point.
- (5) Clean every part, repair any faulty sections and apply a thin coat of oil on metallic parts to prevent rust.
- (6) Store the Hedge Trimmer in a place away from excessive humidity so as to prevent dust from soiling the machine.

## 10. Troubleshooting Guide

Trouble	Probable causes	Action
01. Engine does not start.	Incorrect fuel.	See "5-1. Fuel" on page 6
	Wrong starting procedure used	See "5-2. Starting" on page 6 and 7
	Cable is disconnected.	See "4-3. Connection of cables" on page 6
02. Unusual noise during operation	Screws are loosened.	See "4.Construction" on page 5
	Cutting blades are damaged or worn out.	See "8. Maintenance" on page 9
	Lack of gear case maintenance for an extended period	
03. Lowered productivity	Lack of cutting blade maintenance for an extended period	See "8. Maintenance" on page 9
04. Difficulty in maneuvering	Rear handle is at the wrong angle.	See "7-1. Adjusting rear handle" on page 8

- Attention!**
- [1] If the above troubleshooting guide does not solve your problem, please contact the dealer from which you purchased this machine.
  - [2] When you require further maintenance-related information, also contact the dealer from which you purchased this machine.