

ECHO

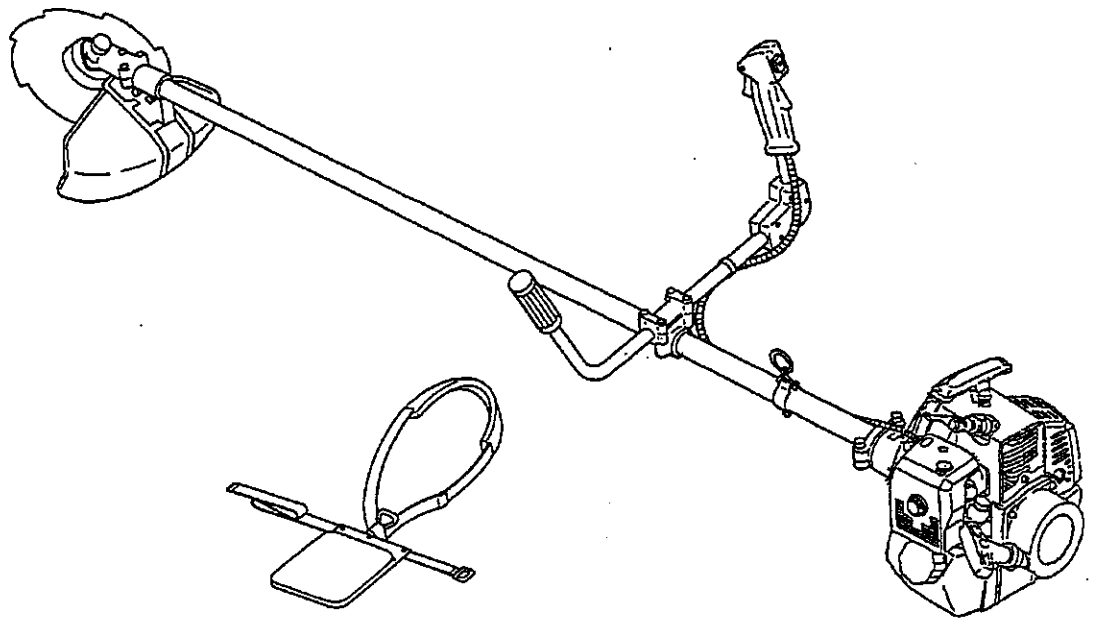

OPERATOR'S MANUAL

ECHO GRASS TRIMMER/ BRUSHCUTTER SRM-3550

U-handle version



CE

WARNING DANGER

READ INSTRUCTIONS CAREFULLY AND
FOLLOW RULES FOR SAFE OPERATION.
FAILURE TO DO SO COULD RESULT IN
SERIOUS INJURY.

INTRODUCTION

ECHO Grass Trimmer/Brushcutters are light-weight, high-performance, petrol engined units designed for weed control, grass trimming and brush cutting in areas difficult to control by any other means.

This manual provides the information necessary for assembly, operation and maintenance. You must read this manual to understand the safe and effective operation of your ECHO product.

NOTE

This manual is for U-HANDLE VERSION of SRM-3550.

CONTENTS

Introduction	1
Rules for Safe Operation	2
Description	10
Assembling	12
Operation	15
Maintenance and Care	17
Trouble Shooting	23
Installing Nylon Line Cutter (Option)	24
Storage	26
Specifications	27
Decals and Symbols	28
Declaration of Conformity	29

Specifications, descriptions and illustrative material in this literature are as accurate as known at the time of publication, but are subject to change without notice. Illustrations may include optional equipment and accessories, and may not include all standard equipment.

WARNING DANGER

READ RULES FOR SAFE OPERATION AND INSTRUCTIONS CAREFULLY.

OPERATOR'S MANUAL MUST BE READ FOR PROPER AND SAFE OPERATION.



THIS SYMBOL ACCOMPANIED BY THE WORDS WARNING AND DANGER CALLS ATTENTIONS TO AN ACT OR A CONDITION WHICH CAN LEAD TO SERIOUS PERSONAL INJURY OR DEATH.

CAUTION

CAUTION indicates a potentially hazardous situation, if not avoided, may result in minor or moderate injury.



Circle and slash symbol means whatever is shown is prohibited.

NOTE

This enclosed message provides tips for use, care and maintenance of the unit.

RULES FOR SAFE OPERATION

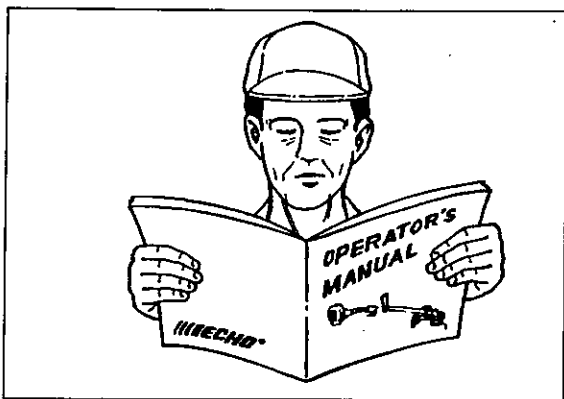

TRAINING

WARNING  **DANGER**
GRASS TRIMMERS AND BRUSHCUTTERS CAN THROW SMALL GRAVEL, STONE, GLASS, METAL OR PLASTIC OBJECTS AS WELL AS THE MATERIAL BEING CUT. READ THESE "RULES FOR SAFE OPERATION" WITH CARE. FOLLOW INSTRUCTIONS IN THE OPERATOR'S MANUAL.

Read the operator's manual carefully. Be thoroughly familiar with the controls and proper use of the unit. Know how to stop the unit and shut off the engine. Know how to unhook a harnessed unit quickly.



Never allow anyone to use the unit without proper instruction. Be sure the operator wears foot, leg, eye and hearing protection and has read this manual.



EYE PROTECTION

The operator must wear eye protection not only against objects thrown by the unit, but also because eye infections can be caused by airborne dust, seeds and pollen. Prescription glasses may be worn under the safety goggles.

Eye protection should also be worn by persons in the risk zone which extends beyond the danger zone.

1. Earmuffs
2. Earplugs



HEARING AND EAR PROTECTION

Prolonged exposure to loud noise can cause impairment or loss of hearing.

Wear suitable hearing protective devices such as earmuffs or earplugs to protect against objectionable or uncomfortable loud noises.

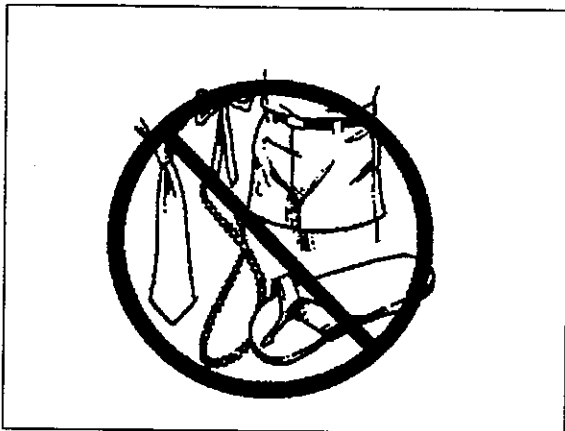

PROTECTIVE CLOTHING

Choose trousers, shirts and jackets that fit trimly and have no strings, frills or dangling straps which could catch on the unit or the underbrush. Do not wear ties, loose clothing or jewelry. Keep clothing buttoned or zipped up and shirt tails tucked in. Secure hair so it is above shoulder length.

The wearing of gloves offers some protection against contact with skin irritants such as poison ivy. Soft leather work gloves may also improve your grip.

FOOT AND LEG PROTECTION

Long trousers and sturdy shoes with non-slip soles are generally acceptable protection against objects thrown by a grass trimmer head. For heavy brush cutting with metal blades, logger's trousers or leg chaps with protective inserts are an added consideration.

ADDITIONAL PROTECTION

Hay fever (rhinitis) sufferers may purchase disposable masks at hardware or medical supply stores to help reduce the intake of allergenic particles.



WARNING  **DANGER**
 IN ADDITION TO HEAD, EYE AND EAR PROTECTION WEAR PROTECTIVE CLOTHES AND SHOES TO PROTECT YOUR FEET FROM THROWN OBJECTS, AND IMPROVE YOUR FOOTING ON SLIPPERY SURFACES. DO NOT WEAR TIES, JEWELRY, OR LOOSE, DANGLING CLOTHING WHICH COULD BE CAUGHT IN THE UNIT. DO NOT WEAR OPEN-TOED FOOTWEAR, OR GO BAREFOOT OR BARELEGGED. IN CERTAIN SITUATIONS YOU MUST ASSESS WHETHER TOTAL FACE AND HEAD PROTECTION MAY BE REQUIRED.

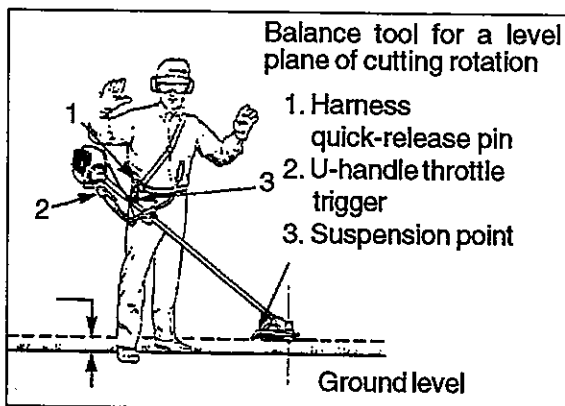

PREPARATION

Use a shoulder harness. Adjust both harness and the suspension point on the unit so the unit hangs with the cutting attachment a few centimeters above ground level. The cutting attachment and guard should be level in all directions. Harness the unit on the right side as shown.

- a) Slide suspension point up and down the tube to find the right balance. Rotate the clamp to level the cutting attachment and guard. Lock in position. If the suspension point is a free-spinning type, the unit may tend to roll over sideways, however, you should still level the attachment and guard on the front-to-rear axis.

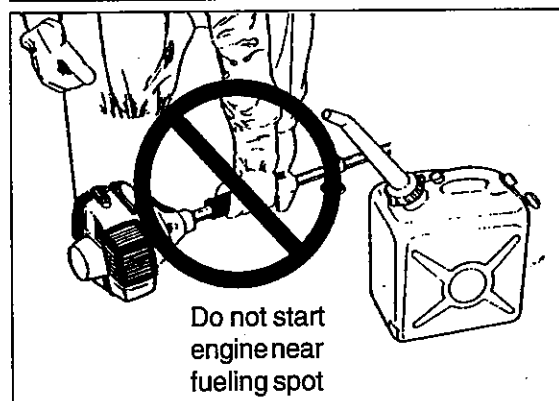
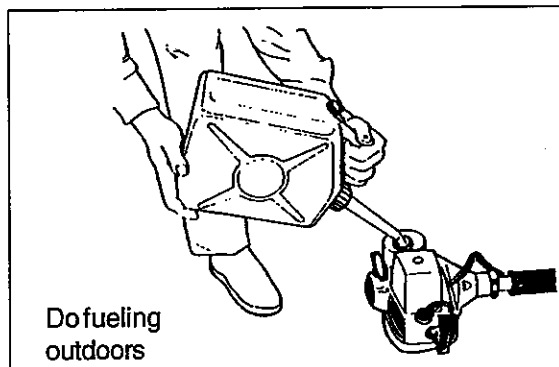
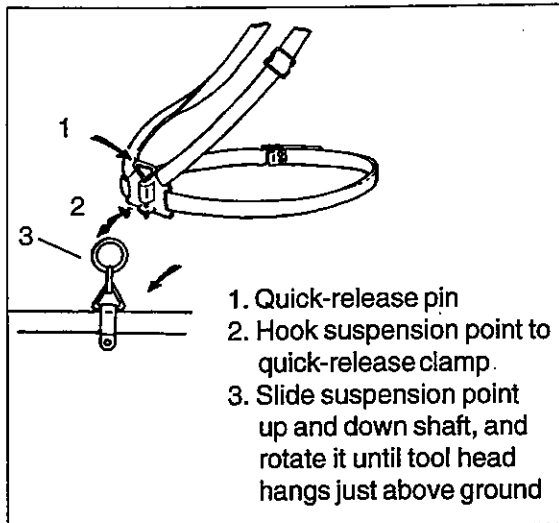

- b) Balancing and levelling, as above, may require relocation of the clamp and readjustment of the harness straps. Also, each type of cutting attachment and guard mounted on the unit may require balancing.

NOTE

A person's size can affect the balancing adjustment. Also the balancing procedure may not work with some ECHO units on some persons. If the procedure does not work for you, please ask your ECHO servicing dealer for assistance.

WARNING  DANGER
ECHO TRIMMERS AND BRUSHCUTTERS ARE DESIGNED TO FIT A WIDE VARIETY OF BODY SIZES, BUT MAY NOT BE ADJUSTABLE FOR EXTREMELY TALL PERSONS. DO NOT USE THE UNIT IF YOUR FEET CAN REACH THE CUTTING ATTACHMENT WHEN THE UNIT IS ATTACHED TO THE HARNESS.

Handle fuel with care. It is highly flammable.

- a) Use an appropriate fuel container.
- b) Do not smoke or bring flame or sparks near fuel supplies.
- c) The fuel tank may be under pressure. Always loosen the fuel cap and wait for pressure to be equalized before removing the cap.
- d) Fill the fuel tank outdoors over bare ground and install the fuel cap securely. Do not pour fuel indoors.
- e) Wipe any spilled fuel off the unit. Then move at least 3 meters (10 feet) from the fueling spot before starting the engine.
- f) Never refuel while the engine is still hot, or fuel a running engine.
- g) Do not store the unit with fuel in its tank, because a fuel leak could start a fire.

You should be in good mental and physical health. Do not operate if you are under the influence of alcohol or any medication or substance which could affect your vision, dexterity or judgement.

Inspect the area before using the unit. Remove objects the unit could throw. Remember where there are obstructions to be avoided.

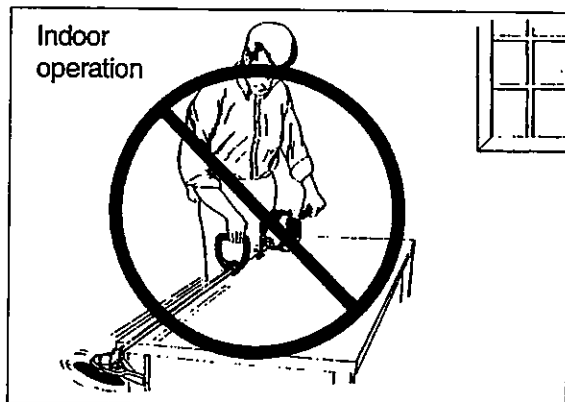
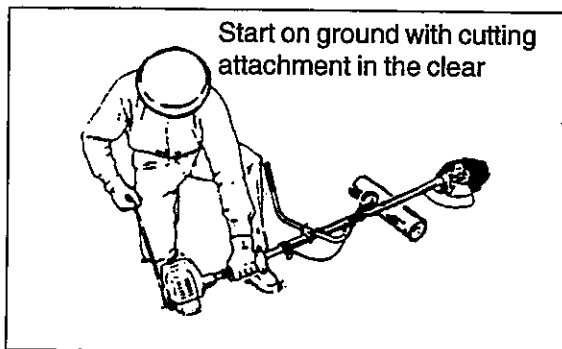
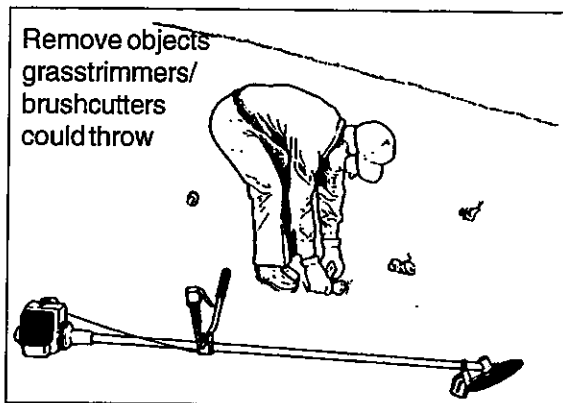
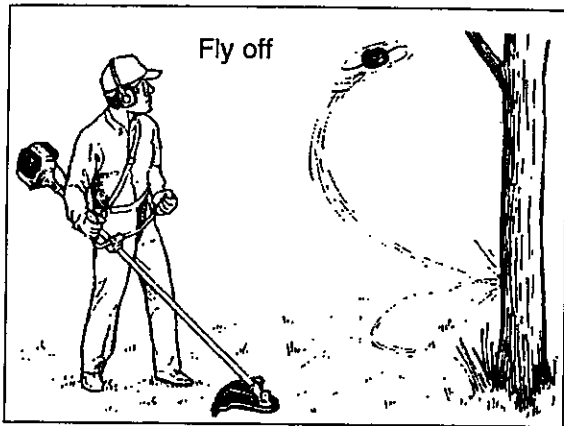

Inspect the unit before using it. Perform only maintenance or adjustments for which the operator's manual gives instruction. Do not try to repair the unit without proper instruction. The unit should be serviced only by trained ECHO dealer servicemen with the proper tools.

Be sure that:

- a) Engine does not leak fuel.
- b) Fasteners are tight, and none are missing.
- c) Silencer is in good condition.
- d) The unit has the proper equipment-guard, handles, harness, etc. -for the cutting attachment to be used.
- e) If used on the unit, the cutting attachment is properly retained with a split pin and nut, is in sharp condition, and has no stress cracks.

WARNING  **DANGER**
IMPROPER FIT WILL RESULT FLY OFF THE CUTTING ATTACHMENT.
NEVER START THE ENGINE IF THE POWER TRANSMISSION SHAFT IS NOT IN PLACE TO PREVENT THE ENGINE FROM OVERSPEEDING OR THE CLUTCH FROM FLYING APART.

GENERAL OPERATION

Do not run the engine indoors, or where there is poor ventilation. Engine fumes contain deadly poisonous carbon monoxide.

Lay the unit down on a clear area and set the controls for starting. Be sure the cutting attachment cannot contact the ground or any obstruction.

Hold the unit firmly down so you will not lose control during starting. Do not start the unit in the air, or from the harness. The unit could swing into your leg or an obstruction if you lose control.

Do not raise the cutting attachment above knee height. If raised higher, the cutting attachment will be more directly in line with your face. Thrown objects may hit your face and eyes.

Wear the recommended foot, leg, head, eye and hearing protection at all times during operation. Also assess the job to be done, and whether other types of protection may be necessary.

Never operate the unit without the proper guards and other protective devices.

Never operate the unit without good visibility and light.

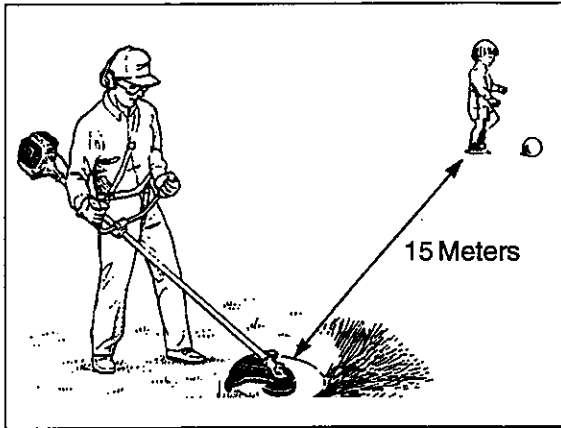

Do not allow anyone to enter the operating **DANGER ZONE** with you. The danger zone is an area of 15 meters (50 feet) in radius.

Insist that persons in the **RISK ZONE** beyond the danger zone wear eye protection from thrown objects. If the unit must be used where there are unprotected people, operate at a low throttle speed to reduce the risk.

Spectators and fellow workers must be warned and children and animals prevented from coming nearer than 15m while the grass trimmer/brushcutters are in use. People working within the 15m radius should wear the same protective equipment as recommended for the operator.

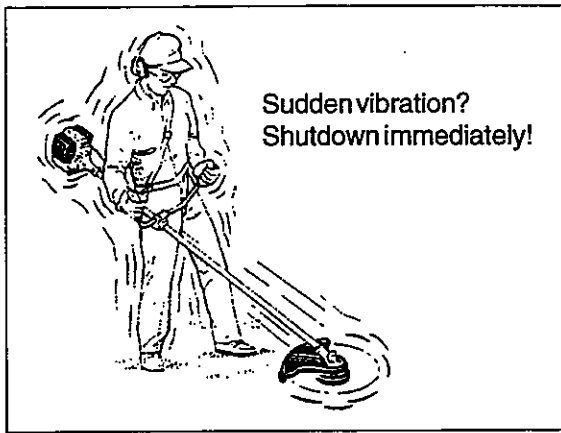

Shut down immediately if the unit starts to shake or vibrate.

A sudden vibration is a sign there may be dangerous trouble, such as a broken flywheel, clutch or cutting attachment, or loose parts.

Do not use the unit until the problem has been properly diagnosed and corrected.

After shutting down the engine, wait until all rotation of the unit stops before going near the cutting attachment. If the cutting attachment rotates after the engine returns to idle, carburettor adjustment is required. You can follow this operator's manual to make the adjustment yourself, or have the carburettor adjusted by your ECHO dealer.

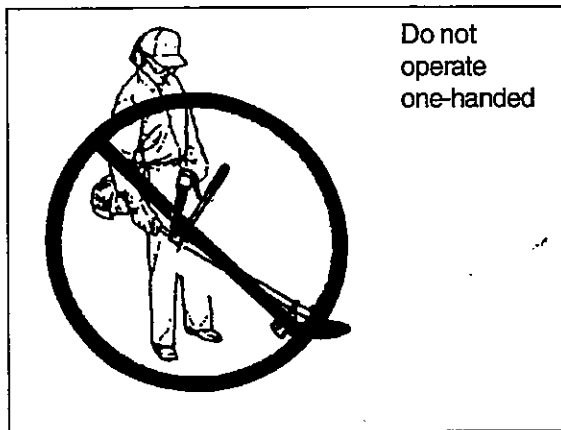

All maintenance and adjustments given in the operator's manual should be performed by you or your ECHO servicing dealer on a timely basis.

All required service or repairs must be done only by the ECHO servicing dealer. Never attempt to use an incomplete machine or one fitted with unauthorized modification.



Always use both hands on the handles. Do not operate one-handed.

Always hold the unit with the fingers and thumbs encircling the handles.

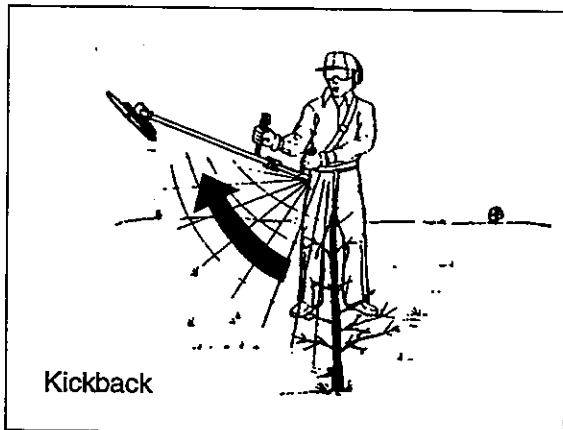
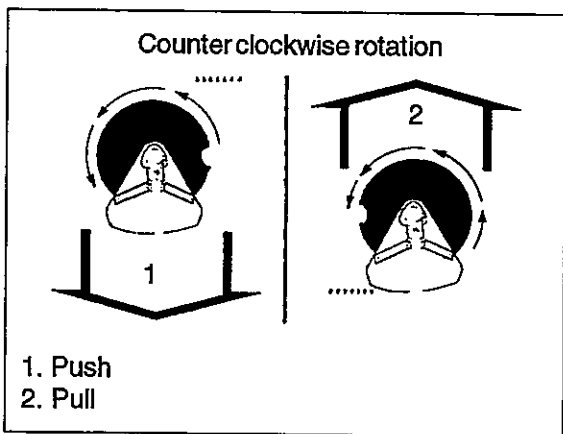
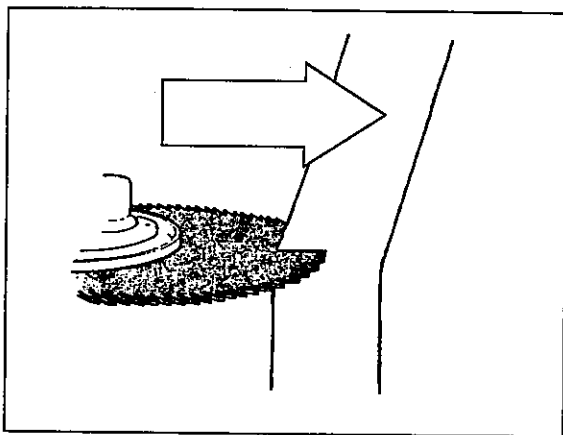
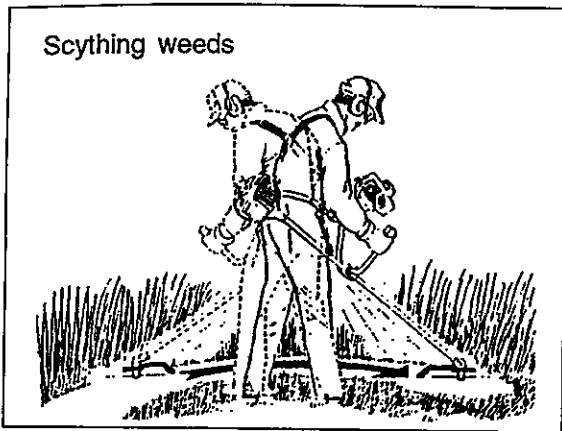

SCYTHING WEEDS. This is cutting by swinging the cutting attachment in a level arc. It can quickly clear areas of field grass and weeds. Scything should not be used to cut large, tough weeds or woody growths.

If a sapling or shrub binds the cutting attachment, do not use the cutting attachment as a lever to free the bind, because this will cause cutting attachment failure.

Instead, shut off the engine and push the sapling or shrub to free the blades.

Do not use a cracked or damaged blade.

WARNING  **DANGER**
ALWAYS STOP THE ENGINE WHEN A CUTTING ATTACHMENT JAM OCCURS. DO NOT ATTEMPT TO REMOVE AN OBJECT CAUSING A JAM IF THE ENGINE IS RUNNING. SEVERE INJURY CAN OCCUR IF A JAM IS REMOVED AND THE CUTTING ATTACHMENT SUDDENLY STARTS.

REACTION FORCES

WARNING  **DANGER**
BE SURE YOU UNDERSTAND THE REACTION FORCES OF PUSH AND PULL, AND KICK-BACK DESCRIBED IN THIS MANUAL, AND HOW THESE FORCES MAY AFFECT YOUR BALANCE IN THE OPERATION OF A UNIT.

PUSH. The operator feels the unit push toward him when he tries to saw with the blade on the side where the teeth are moving away from him. If he cannot hold the blade in the cut, a kick-back may occur when the blade is pushed out to where the teeth at the outside furthest point from the operator are cutting. The blade will "kick-back" sideways.

KICK-BACK. This may occur when the moving blade at the front of the blade circle contacts strong brush or trees. The force that occurs pushes the entire unit and blade violently away in an arc. Kick-back is a danger to a bystander and also a jolting force to the operator.

PULL. The opposite of push. When the part of the blade where the teeth are moving towards the operator is used for cutting, the reaction is a pull away from the operator. Although this pull type of cutting may cause sawdust to be thrown back at the operator, it is recommended for sawing off heavy brush because the cutting is smoother and more stable than when the unit pushes.

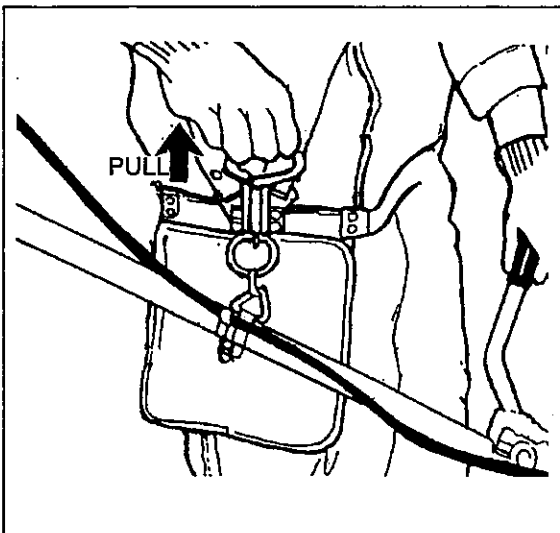
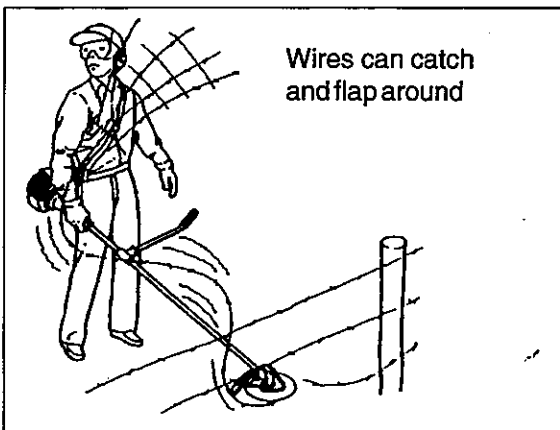
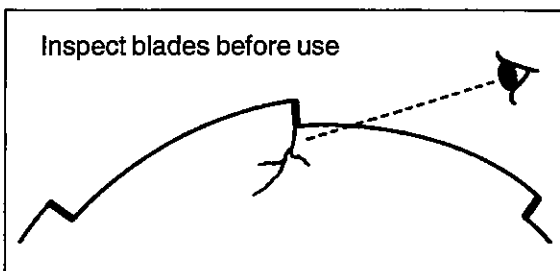
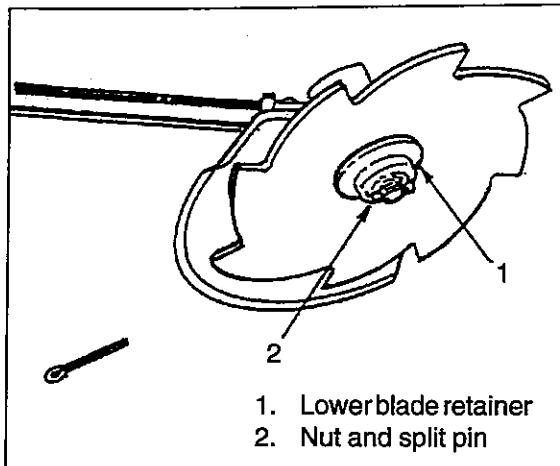

USE CORRECT BLADE

WARNING DANGER

- SERIOUS INJURY MAY RESULT FROM THE IMPROPER USE OF BLADES. READ AND COMPLY WITH ALL SAFETY INSTRUCTIONS LISTED IN THIS MANUAL.
- THE EIGHT-TOOTH BLADE IS DESIGNED ESPECIALLY TO CUT WEEDS AND GRASS. TO AVOID INJURY DUE TO KICK-BACK OR BLADE FRACTURE, DO NOT USE THE EIGHT-TOOTH BLADE TO CUT BRUSH OR TREES. USE CIRCULAR SAW BLADE TO CUT BRUSH OR SMALL TREES.
- USE ONLY CUTTING ATTACHMENTS RECOMMENDED BY ECHO.

WARNING DANGER

PIECES FROM A CRACKED METAL BLADE CAN FLY OFF DURING OPERATION. INSPECT METAL BLADES FOR CRACKS BEFORE EACH USE. DISCARD CRACKED BLADES NO MATTER HOW SMALL THE CRACK. CRACKED BLADES CAN BE THE RESULT OF MISUSE OR IMPROPER SHARPENING.

- Always use the blade suited for the job.
- Do not hit rocks, stones, tree stumps, and other foreign objects with the blade.
- Do not cut into the ground with the blade.
- If blade strikes an obstruction, stop engine immediately and inspect blade for damage.
- Do not operate with a dull, bent, fractured or discoloured blade and worn or damaged nut.
- Do not run engine at full throttle without a load.
- Remove all foreign objects from work area.
- Do not operate brushcutter without shoulder harness and guard.
- In case of an emergency, use quick-release pin on harness to free yourself from unit.
- Keep bystanders 15 meters (50 feet) from operator.
- Always carry unit with the engine stopped and the HOT silencer away from your body.
- Always stop the unit when transporting, storing and servicing the unit.

WARNING DANGER

BEYOND THE 15 METERS DANGER ZONE THERE STILL MAY BE RISK OF EYE INJURY FROM THROWN OBJECTS. THE RISK DIMISHES WITH DISTANCE. BUT EYE PROTECTION SHOULD BE CONSIDERED FOR EVERYONE IN THE ZONE OF RISK.

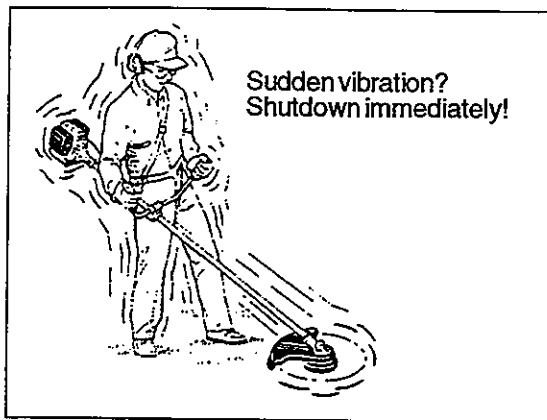

VIBRATION AND COLD

It is believed that a condition called Raynaud's Phenomenon which affects the fingers of certain individuals may be brought about by exposure to vibration and cold. Exposure to vibration and cold may cause tingling and burning, followed by loss of colour and numbness in the fingers. The following precautions are strongly recommended because the minimum exposure which might trigger the ailment is unknown.

- Keep your body warm, especially the head and neck, feet and ankles, and hands and wrists.
- Maintain good blood circulation by performing vigorous arm exercises during frequent work breaks, and also by not smoking.
- Limit the number of hours of operation. Try to fill each day with jobs where operating the trimmer or other hand-held power equipment is not required.
- If you experience discomfort, redness and swelling of the fingers, followed by whitening and loss of feeling, consult your physician before exposing yourself further to cold and vibration.

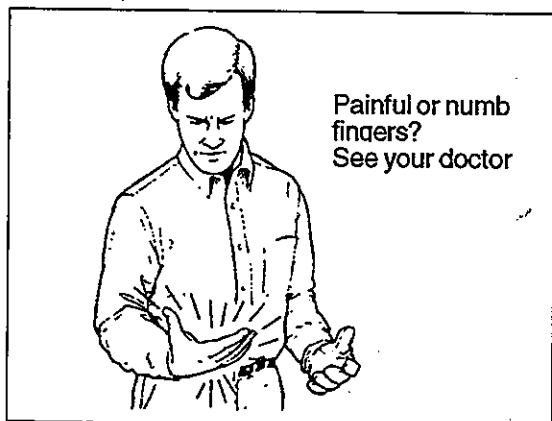

REPETITIVE STRESS INJURIES

It is believed that overusing the muscles and tendons of the fingers, hands, arms and shoulders may cause soreness, swelling, numbness, weakness and extreme pain to the areas just mentioned. Certain repetitive hand activities may put you at a high risk for developing a repetitive stress injury (RSI).

To reduce the risk of RSI, do the following:

- Avoid using your wrist in a bent, extended or twisted position.
- Take periodic breaks to minimize repetition and rest your hands.
- Reduce the speed and force in which you do the repetitive movement.
- Do exercises to strengthen hand and arm muscles.
- See a doctor if you feel tingling, numbness or pain in your fingers, hands, wrists or arms. The sooner RSI is diagnosed, the more likely permanent nerve and muscle damage can be prevented.

DESCRIPTION

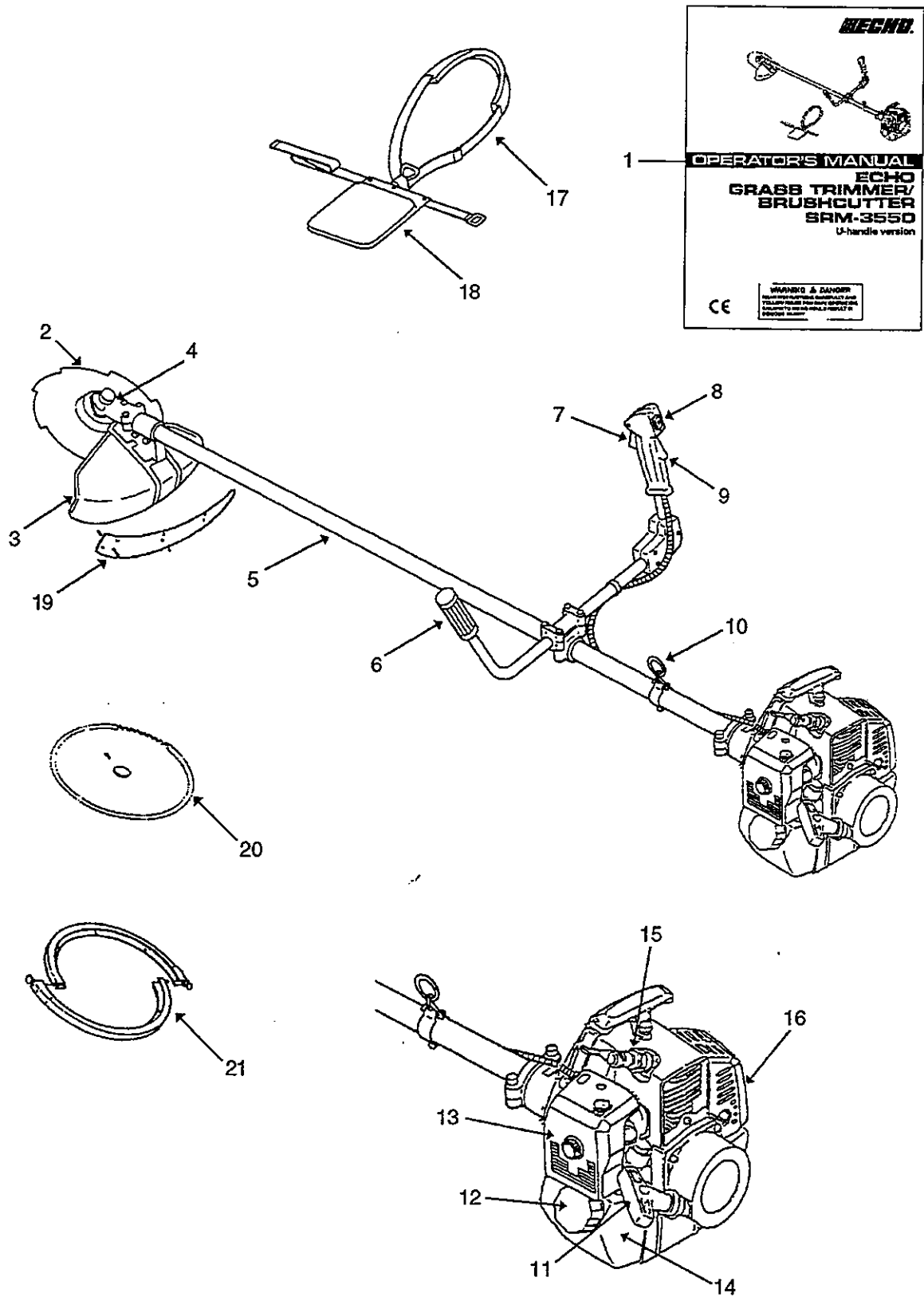

DESCRIPTION

- 1 **OPERATOR'S MANUAL** Included with unit. Read before operation and keep for future reference to learn proper, safe operating techniques.
- 2 **CUTTING ATTACHMENT** 8 tooth blade for cutting grass, garden debris and weeds.
- 3 **CUTTING ATTACHMENT GUARD** Device to protect the operator from accidental contact with the cutting head and thrown objects.
- 4 **ANGLE TRANSMISSION** Having two gears to change the angle of rotating axis.
- 5 **SHAFT TUBE** Part of the unit that provides a casing for power transmission shaft.
- 6 **U-HANDLE** Having the configuration of a bicycle handle bar to reduce working effort compared to a loop-handle.
- 7 **THROTTLE TRIGGER** Spring loaded to return to idle when released. When accelerating, press trigger gradually for best operating technique, DO NOT hold trigger when starting.
- 8 **IGNITION SWITCH** "Slide Switch" mounted on top of the Throttle Trigger Housing, move switch upwards to RUN , downwards to STOP position.
- 9 **THROTTLE TRIGGER LOCKOUT** Locks throttle trigger in the idling position until you have a proper grip with your right hand around the handle.
- 10 **SUSPENSION POINT** Device on which the harness can be hooked.
- 11 **STARTER HANDLE** Pull handle slowly until starter engages, then quickly and firmly. When engine starts, return handle slowly. DO NOT let handle snap back or damage to unit will occur.
- 12 **FUEL TANK CAP** Covers and seals fuel tank.
- 13 **AIR CLEANER COVER** Covers and seals air filter.
- 14 **FUEL TANK** Contains fuel and fuel filter.
- 15 **SPARK PLUG**
- 16 **SILENCER COVER** Cover for the silencer to prevent operator contact with the hot exhaust.
- 17 **SHOULDER HARNESS** An adjustable strap and waist belt to suspend unit.
- 18 **HIP PAD** Used to protect hip/leg and clothing when using U-handle equipped unit.
- 19 **GUARD PLATE** Extension guard used with nylon cutter.
- 20 **CUTTING ATTACHMENT** Circular saw for sawing heavy brush and small trees.
- 21 **BLADE COVER** Cover for blade used when unit is being transported.

ASSEMBLING

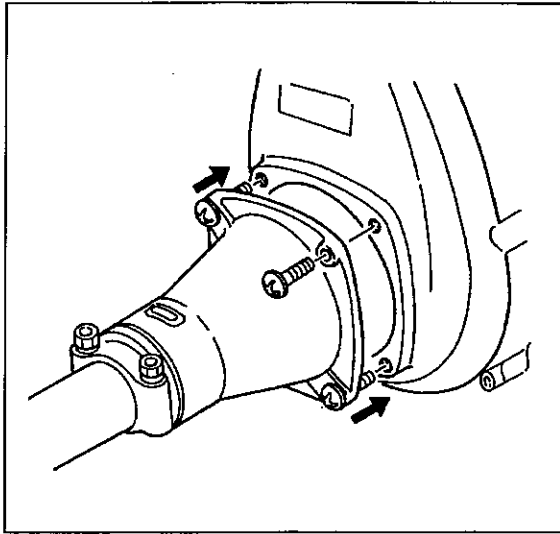

SHAFT TUBE

1. Stand engine upright on a level surface.
2. Rotate the shaft tube assembly until angle transmission is in line with the engine.
3. Secure shaft tube assembly to engine with screws.

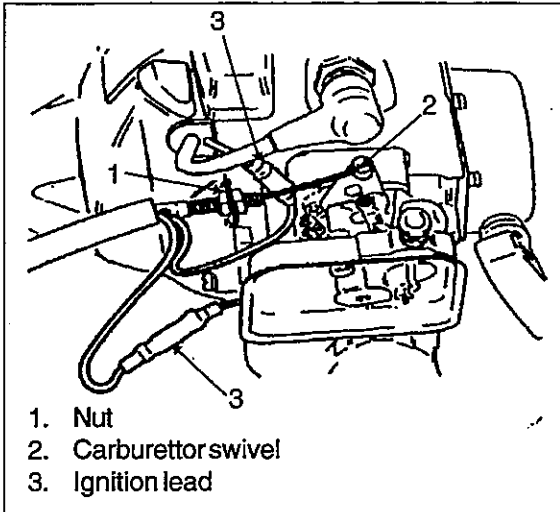

THROTTLE CABLE AND IGNITION LEADS

1. Close choke and remove air filter cover.
2. Loosen nut and place threaded cable housing in bracket slot. If there are flat washers between the two nuts, place one on each side of the bracket. Finger tighten nut.
3. Place inner cable in slot of carburetor swivel and tighten nut.
4. Check to make sure throttle operates freely, opens completely and returns to idle.
5. Connect ignition leads. This unit has one spade terminal pair and one ring terminal which is secured under fan cover screw.
6. Re-install air cleaner cover.

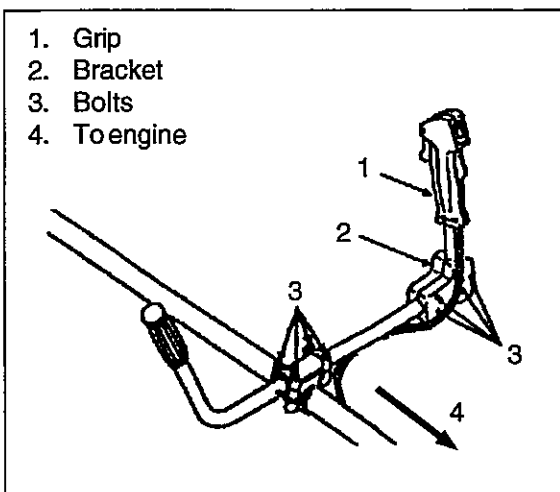

U-HANDLE

- Remove right handle bracket from handle bar.
- Loosen handle bar support bolts.
- Assemble right hand grip, and handle bar and brackets as shown. Locate grips and handle bar in a comfortable operating position and tighten bolts.

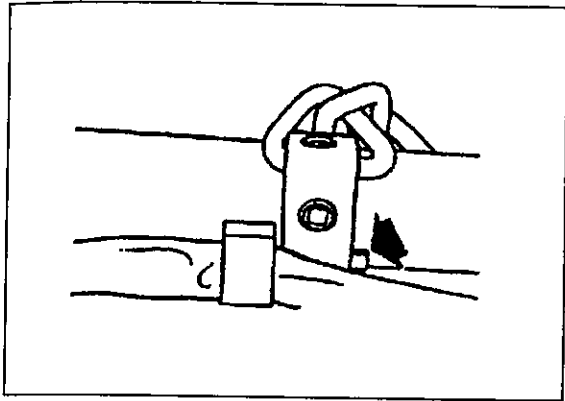

Secure throttle cable and leads to shaft tube by sliding wedge under harness suspension point.

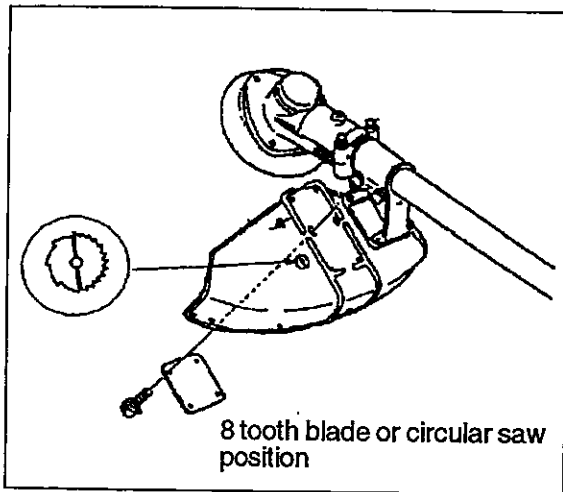

INSTALLATION OF GUARD FOR METAL BLADE

Align the bracket with 8 tooth blade/circular saw position mark on the guard.

Fit the guard on the bracket and tighten four M5 x 18 screws.

For safe operation, never use the unit without guard.

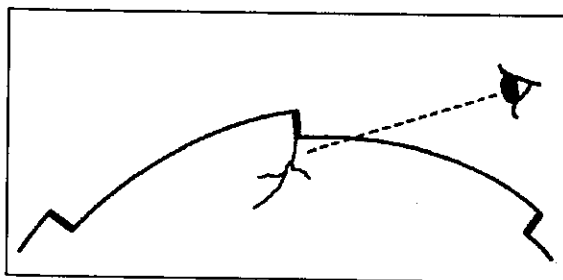

INSTALLING BLADE

Inspect blades before installation. Check for sharpness. Dull blades increase the risk of blade kick-back reactions. Small cracks can develop into fractures resulting in a piece of blade flying off during operation.

Discard cracked blades no matter how small the crack.

Use a locking tool to prevent the output shaft from turning during blade installation.

Install blade retainer, blade, lower blade retainer and nut finger tight.

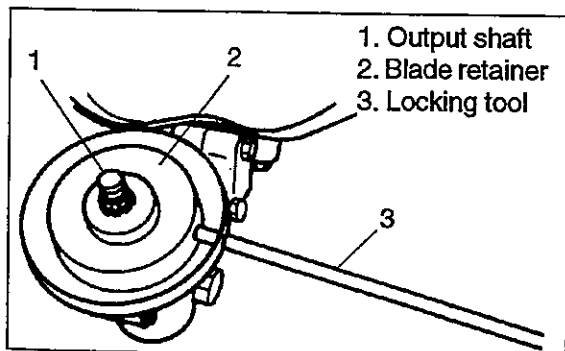

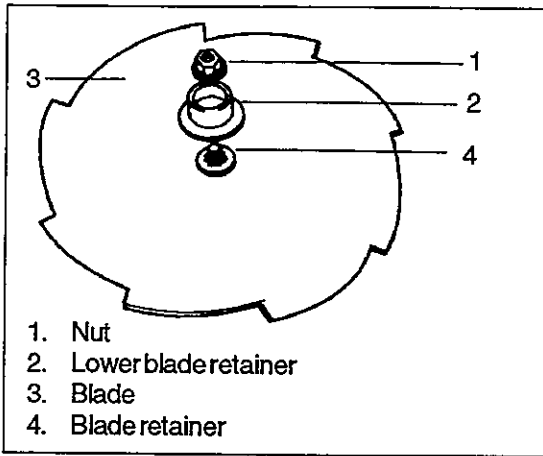

NOTE

Check to be sure the locking tool is fully engaged to prevent the output shaft from turning.

Tighten the nut (turn counterclockwise) using a socket wrench.

Secure the nut using a new split pin.

CAUTION

Wear gloves to reduce the risk of injury caused by unintentional contact with the blade.

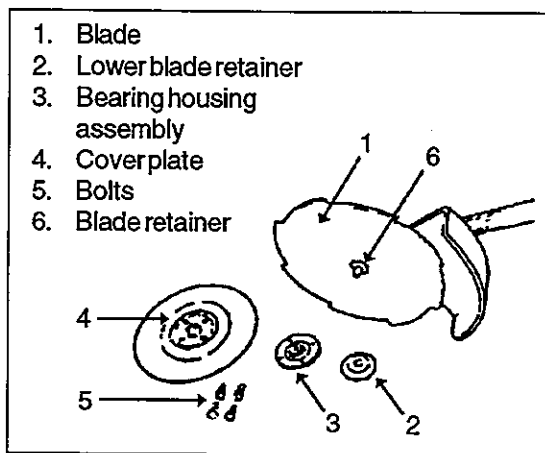

INSTALLING COVER PLATE FOR CUTTER BLADE

- Fit the blade onto the blade retainer, fit the lower blade retainer and secure by tightening the nut with bearing housing assembly.

CAUTION

It will not be possible to fit the split pin with the cover plate in use.

- Offer the cover plate up to the bearing housing assembly and secure with the four bolts.
- Ensure the cover plate can be rotated freely by hand.

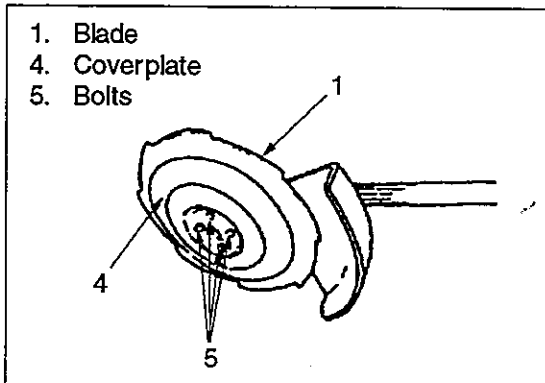

CAUTION

Use this lower blade retainer together with 1.4 mm cutting blade and cover plate assembly.

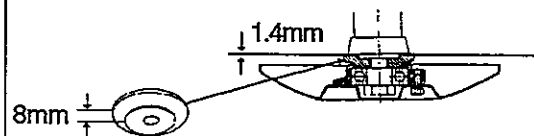

CAUTION

Use this lower blade retainer together with 3.5 mm cutting blade and cover plate assembly.

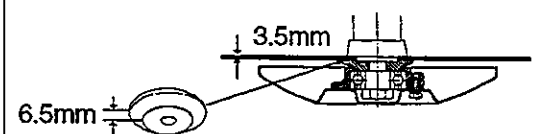

OPERATION

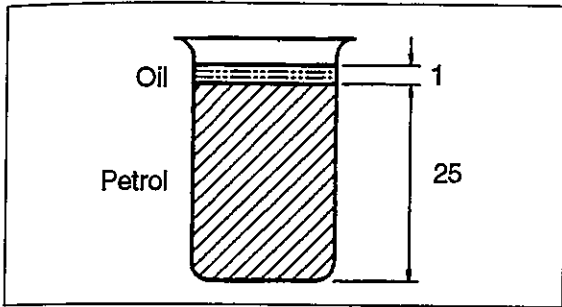

Fuel Mix Chart

Metric		Imperial	
Petrol	Oil	Petrol	Oil
Litres	C.C.	Gal.	Fl. Oz.
4	160	1	6.4
8	320	2	12.8
20	800	5	32.0

FUEL

- Fuel used for this model is a mixture of Regular grade petrol and a normal two stroke engine oil of a reputable brand name.
- Mixture ratio is petrol 25 parts : Oil 1 part.
- Fuel mixture at the ratio other than 25 : 1 may cause malfunction of the engine.
- Ensure mixture ratio is correct.

CAUTION

Stored fuel ages. Do not mix more fuel than you expect to use in thirty (30) days, ninety (90) days when a fuel stabilizer is added.

Stored two-stroke fuel may separate. **ALWAYS** shake fuel container thoroughly before each use. Do not mix directly in fuel tank.

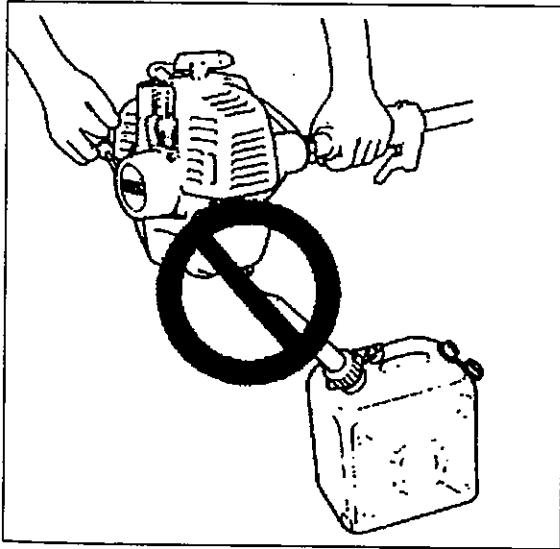

HANDLING FUEL

- Never smoke or allow flame or sparks near fuel.
- Always fill the fuel tank outdoors.
- Never pour fuel indoors.
- Never refuel the engine when it is hot or running.
- Always use an approved, safe fuel container.
- After fueling, always wipe away spilled fuel.
- Always move at least 3 meters (10 feet) away from the fueling spot before starting the engine.
- Never store the unit with fuel in the tank a fuel leak could start a fire.

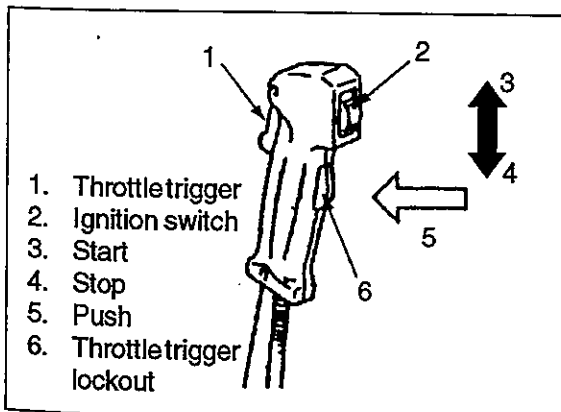

STARTING COLD ENGINE

WARNING  **DANGER**
WHEN ENGINE STARTS, THE CUTTING ATTACHMENT MAY ROTATE, EVEN WITH THROTTLE TRIGGER IN LOW-SPEED POSITION.

- Place ignition switch in START position.

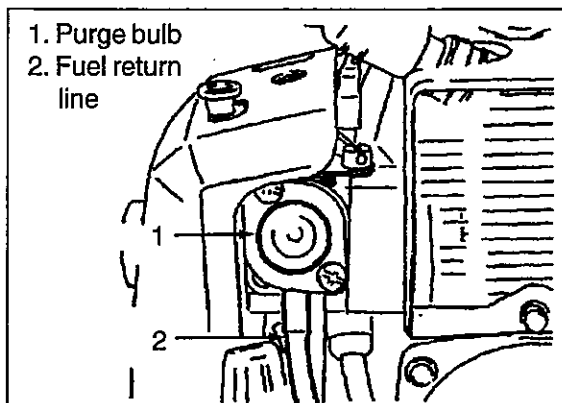

- Push purge bulb until fuel is visible in clear fuel return line.
- Pull choke knob up to CLOSE position.
- Pull starter handle until the first firing sound.
- Push choke knob down to OPEN position.
- Restart engine and allow to warm up.

NOTE

- Check unit for loose nuts, bolts and screws before starting.
- Always clear work area of debris before starting operation.
- Always hold the unit firmly on the ground.
- When pulling starter handle, use short pulls, 1/2 to 2/3 of rope length.
- Do not allow the starter handle to snap back against the housing.

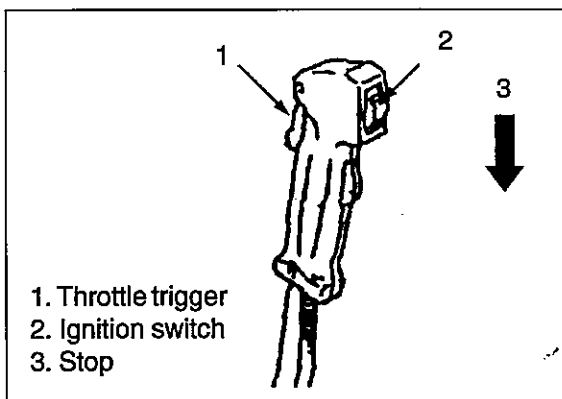
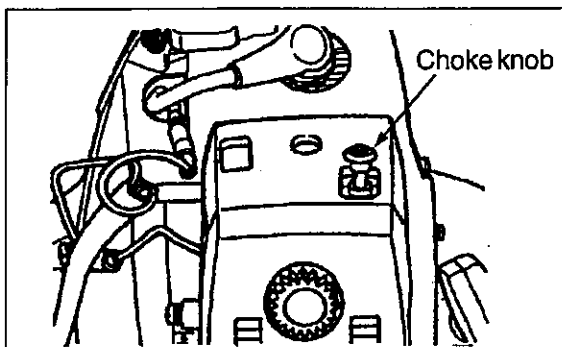

STARTING WARM ENGINE

- Place ignition switch in START position.
- Move choke lever to OPEN position.
- If the tank is not empty, pull starter handle.
- If fuel tank is empty, after refilling, push the purge bulb (until fuel is visible in clear fuel return line).
- Pull starter handle.

NOTE

If engine does not start after 4 pulls, use Cold Starting Procedure.

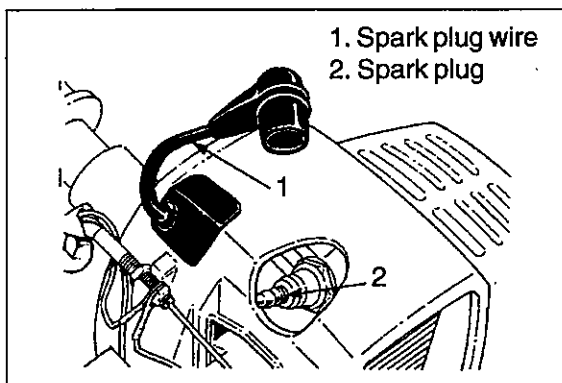

STOPPING ENGINE

- Release throttle trigger and allow engine to idle.
- Place ignition switch in STOP position.

WARNING  **DANGER**
IF ENGINE DOES NOT STOP, CLOSE CHOKE TO STALL ENGINE. HAVE YOUR ECHO DEALER INSPECT AND REPAIR IGNITION SWITCH BEFORE USING THE UNIT.

Always disconnect spark plug wire from the spark plug to ensure that the engine cannot be started before you work on the unit or leave it unattended.

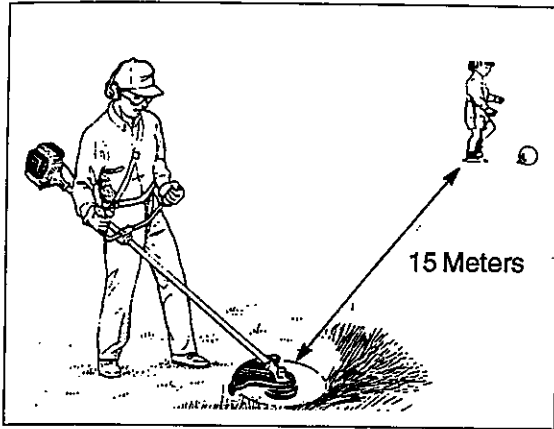

OPERATING THE UNIT

Spectators and fellow workers must be warned and children and animals prevented from coming near than 15 meters (50 feet) while the grasstrimmer/brushcutter is in use.

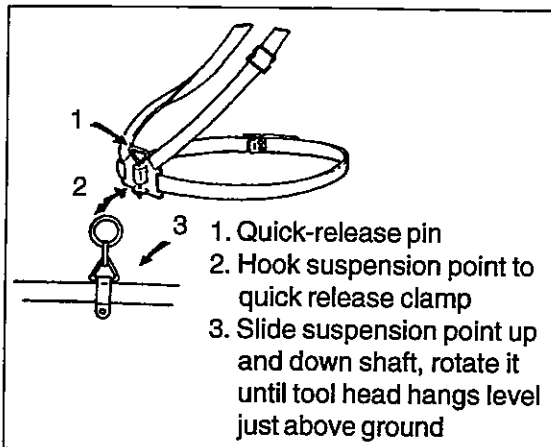

USING SHOULDER HARNESS

Place shoulder harness over left shoulder and adjust straps so the quick-release pin rests just below the waist.

Buckle waist belt. Belt should be snug.

Attach Grasstrimmer/Brushcutter to harness.

Check for correct adjustment by moving cutting attachment along ground.

See Rules for Safe Operation for proper adjustment.

Re-adjust bracket if necessary.

WARNING  **DANGER**
 IN CASE OF AN EMERGENCY, PULL UP
 ON THE QUICK-RELEASE PIN ON HAR-
 NNESS TO FREE YOURSELF FROM UNIT.

MAINTENANCE AND CARE

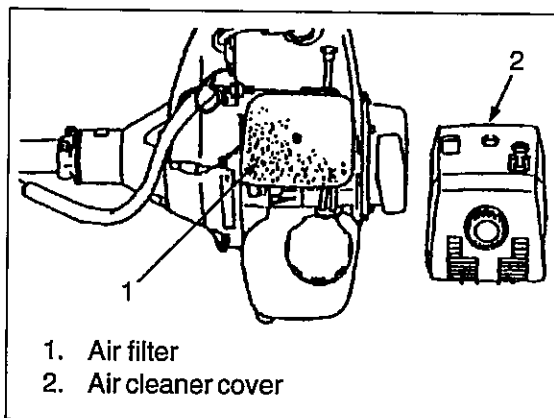

CLEANING AIR FILTER

- Close choke . Loosen screw and remove air cleaner cover.
- Remove air filter.
- Brush dirt from filter or wash it in a suitable cleaner.
- Reinstall filter.
- Reinstall cover and tighten screw.

NOTE

If filter is excessive dirty or no longer fits properly, replace it.

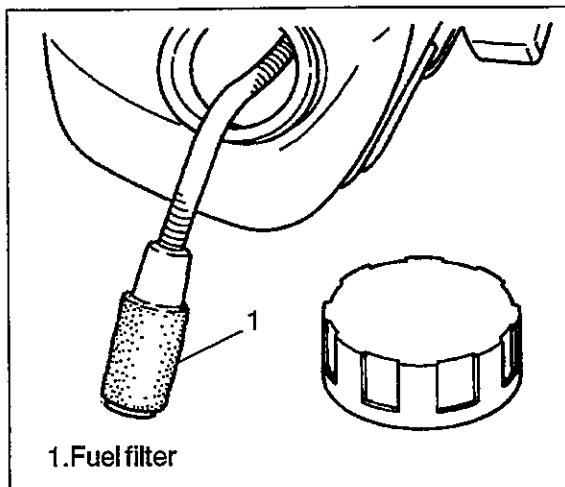

REPLACING FUEL FILTER

- Use a piece of steel wire or the like to pick up fuel filter through fuel tank opening.
- Pull old filter from fuel line.
- Install new fuel filter.

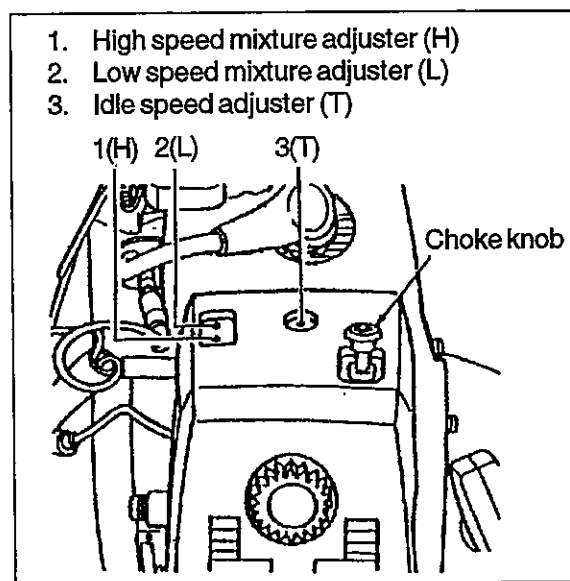

CARBURETTOR ADJUSTMENT

Every unit is test run at the factory and the carburettor is fine tuned for maximum performance. Any change from this setting should be performed only with the aid of an accurate tachometer (see Specification for rpm setting). If carburettor adjustment is performed without a tachometer, only the Basic Setting adjustment is recommended.

Before adjusting carburettor, clean or replace air filter, start engine and run several minutes to bring it to operating temperature.

IDLE SPEED ADJUSTMENT

Turn "idle" speed adjuster clockwise until cutting attachment begins to turn, then turn screw out counterclockwise until cutting attachment stops turning.

Turn screw out, counterclockwise and additional 1/4 turn.

CAUTION

Cutting attachment must not turn when unit is idling.

BASIC SETTING

1. Stop engine and turn both low (L) and high (H) speed mixture adjusters in, clockwise until they stop and are lightly seated.

CAUTION

DO NOT overtighten (L)/(H) adjusters. Forcing them to tighten will damage the carburettor.

2. Turn low speed mixture adjuster (L) out, counterclockwise 1-1/2 turn. Turn high speed mixture adjuster (H) out counterclockwise 1-1/2 turn.

1. High speed mixture adjuster (H)
2. Low speed mixture adjuster (L)
3. Idle speed adjuster (T)

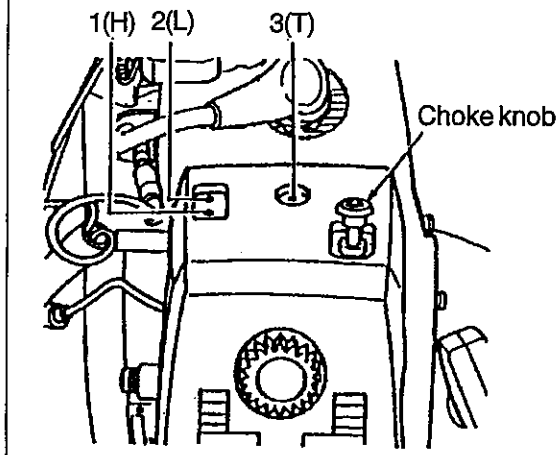

FINE TUNING

(Requires Accurate Tachometer)

1. Start engine and allow to run at high idle until warm.
2. Adjust idle speed if necessary (2500 - 3000 rpm).
3. Always begin fine tuning with low speed mixture adjuster (L).
4. Slowly turn (L) adjuster clockwise, try to reach maximum idle speed.
5. Turn (L) adjuster counterclockwise 1/8 - 1/4 turn.
6. Turn idle speed adjuster clockwise until cutting attachment begins to turn.
7. Turn idle speed adjuster counterclockwise 1/2 turn or until cutting attachment stops.

HIGH SPEED ADJUSTMENT

CAUTION

Improper high speed mixture adjustment can result in lean operation and consequent severe engine damage.

1. While running the engine at full throttle, turn (H) adjuster slowly clockwise until engine runs smoothly under no load.

CAUTION

Do not run engine on full throttle longer than 5 - 6 seconds during high speed mixture adjuster (H) adjustment to avoid damage to engine.

2. Turn (H) adjuster counterclockwise 1/8 turn to obtain optimum fuel for full power under the load conditions.
3. After the high speed adjustment has been completed, and should the engine hesitate during acceleration from idle to full throttle, turn (H) adjuster counterclockwise until smooth acceleration is obtained. Make sure that the final engine speed does not exceed 11,500 rpm..

CAUTION

The engine will overheat when the high speed mixture adjuster (H) is adjusted to the lean condition reducing engine life.

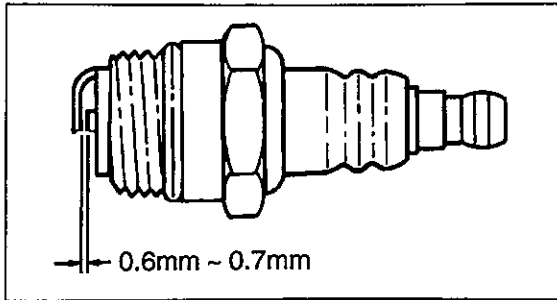

CHECK SPARK PLUG

- Check plug gap. Correct gap is 0.6 ~ 0.7 mm (.024 ~ .028 in).
- Inspect electrode for wear.
- Inspect insulator for oil or other deposits.
- Replace plug if needed and tighten to 145 ~ 155 kgfcm (125 ~ 135 in.lb).

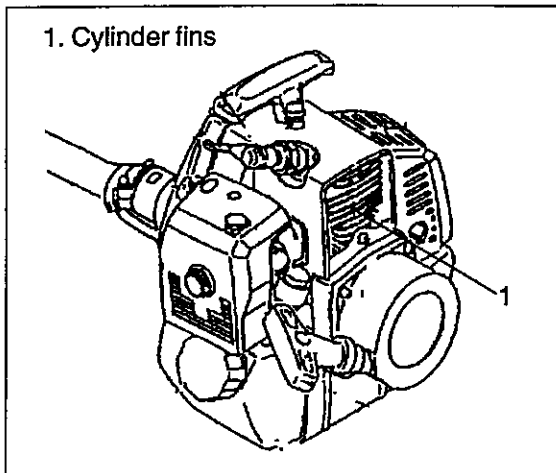

COOLING SYSTEM MAINTENANCE

CAUTION

To maintain proper engine operating temperature, cooling air must pass freely through the cylinder fin area. This flow of air carries combustion heat away from the engine.

Overheating and engine seizure can occur when:

- Air intakes are blocked, preventing cooling air from reaching the cylinder,
- or
- Dust and grass build up on the outside of the cylinder. This build-up insulates the engine and prevents the heat from leaving.

Removal of cooling passage blockages or cleaning of cylinder fins is considered "Normal Maintenance". Any resultant failure attributed to lack of maintenance is not warranted.

- Remove dust and dirt from between fins.

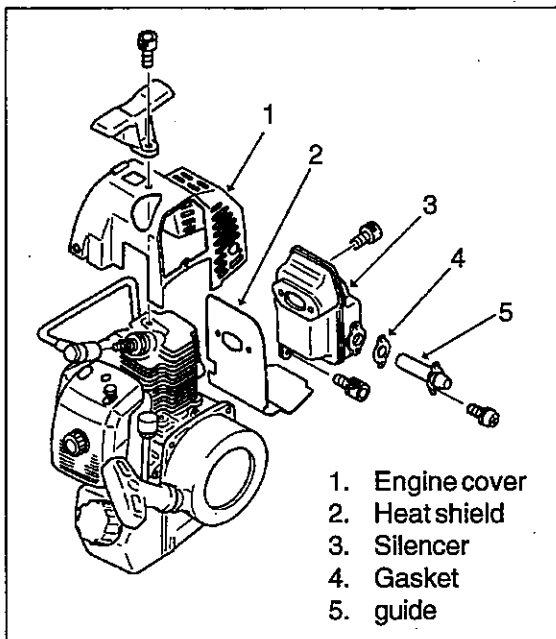

CLEANING SILENCER AND EXHAUST PORT

- Remove spark plug lead from spark plug, and throttle cable from carburettor swivel.
- Remove the four screws which secure engine cover.
- Remove engine cover.
- Remove silencer and heat shield.
- Place piston at top dead centre. Clean deposits from silencer and cylinder exhaust port.

NOTE

Be careful not to scratch the cylinder or piston when cleaning the cylinder exhaust port.

- Inspect gasket, replace if damaged.
- Install heat shield and silencer.
- Install silencer lid.
- Install engine cover and spark plug lead.

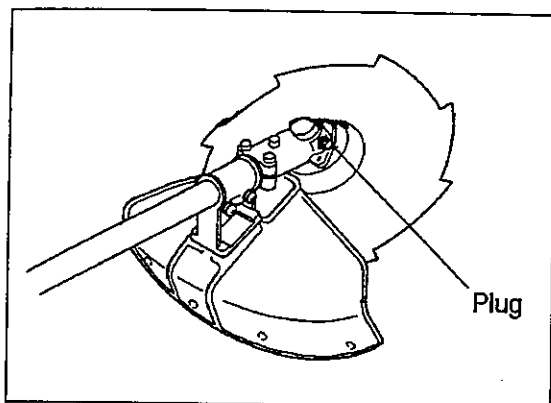

ANGLE TRANSMISSION AND SHAFT TUBE

- Remove plug from angle transmission.
- Add grease, if necessary, using low pressure pump.

NOTE

Use good quality lithium multi grease. DO NOT overfill housing.

- Reinstall plug.

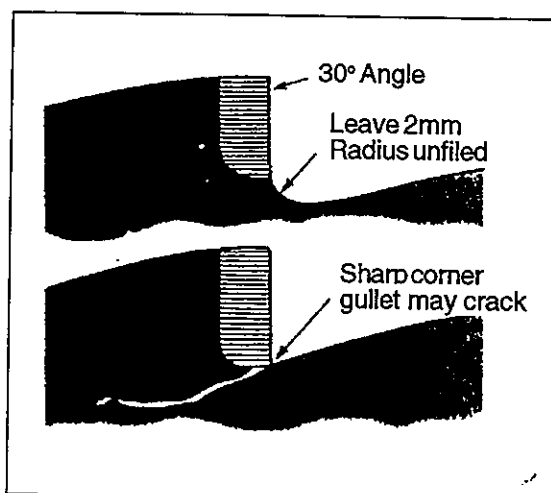

NOTE

File the bottom of the teeth of a 1-2 mm radius with round file.

SHARPENING THE 8 -TOOTH BLADE

- Use only the blade designated for this model by the manufacturer.
- The blade has to be well levelled and sharpened, the root of the tooth should be filed to a 2mm radius.
 - Radius the root of the tooth by 1-2mm in order to prevent cracking, using a half round file or a round file and flat file.
 - The radiused part is not to be sharpened.
 - Sharpen each cutter equally so as to retain the balance of the blade.
 - When sharpening with a grinde, do not cool the cutter abruptly by immersing it in water.
- When a crack is noticed on the blade, do not use it but replace with a new one.
- Ensure that the blade is correctly fitted in accordance with the instructions.
- The sharpening of the blade is a specialized operation and should be referred to you local blade repair shop.

NOTE

Sharpen each cutter equally.

NOTE

If using a grinding machine, do not cool blade abruptly immersing it in water.

SERVICE GUIDE

AREA	MAINTENANCE	PAGE	BEFORE USE	MONTHLY	YEARLY
Air Filter	Clean/Replace	17	•		
Fuel Filter	Inspect/Replace	18	•		
Spark Plug	Inspect/Clean	20		•	
Carburettor	Adjust/Replace	18		•	
Cylinder Fins	Inspect/Clean	20			•
Silencer	Inspect/Clean	20	•		
Shaft Tube	Grease	21		•	
Angle Transmission	Grease	21			•*
Starter Rope	Inspect/Replace	-		•	
Fuel System	Inspect/Repair	-	•		
Screw, Bolts & Nuts	Inspect, Tighten/Replace	-	•		

IMPORTANT

Time intervals are maximum. Actual use and your experience will determine the frequency of required maintenance.

* Or 50 hours, whichever occurs first.

TROUBLESHOOTING

Trouble		Cause	Remedy
Engine	- starts hard - does not start		
Engine cranks	Fuel at carburettor → No fuel at carburettor	<ul style="list-style-type: none"> • Fuel strainer clogged • Fuel line clogged • Carburettor 	<ul style="list-style-type: none"> • Clean • Clean • See your Echo dealer
	↓ Fuel at cylinder → No fuel at cylinder	<ul style="list-style-type: none"> • Carburettor 	<ul style="list-style-type: none"> • See your Echo dealer
	↓ Silencer wet with fuel	<ul style="list-style-type: none"> • Fuel mixture is too rich 	<ul style="list-style-type: none"> • Open choke • Clean/replace air filter • Adjust carburettor • See your Echo dealer
	Spark at end of plug wire → No spark at end of plug wire	<ul style="list-style-type: none"> • Ignition switch off • Electrical problem 	<ul style="list-style-type: none"> • Turn switch on • See your Echo dealer
	Spark at plug → No spark at plug	<ul style="list-style-type: none"> • Spark gap incorrect • Covered with carbon • Fouled with fuel • Spark plug defective 	<ul style="list-style-type: none"> • Adjust 0.6 ~ 0.7 mm (0.024 ~ 0.028 in) • Clean or replace • Clean or replace • Replace plug
Engine does not crank		<ul style="list-style-type: none"> • Internal engine problem 	<ul style="list-style-type: none"> • See your Echo dealer
Engine runs	Dies or accelerates poorly	<ul style="list-style-type: none"> • Air filter dirty • Fuel filter dirty • Fuel vent plugged • Spark plug • Carburettor • Cooling system plugged • Exhaust port/silencer lid plugged 	<ul style="list-style-type: none"> • Clean or replace • Replace • Clean • Clean and adjust/replace • Adjust • Clean • Clean

WARNING  DANGER
ALL TRIMMER SERVICING, OTHER THAN THE ITEMS LISTED IN THE OPERATOR'S MANUAL SHOULD BE PERFORMED BY COMPETENT TRIMMER SERVICE PERSONNEL.

INSTALLING NYLON LINE CUTTER (OPTION)

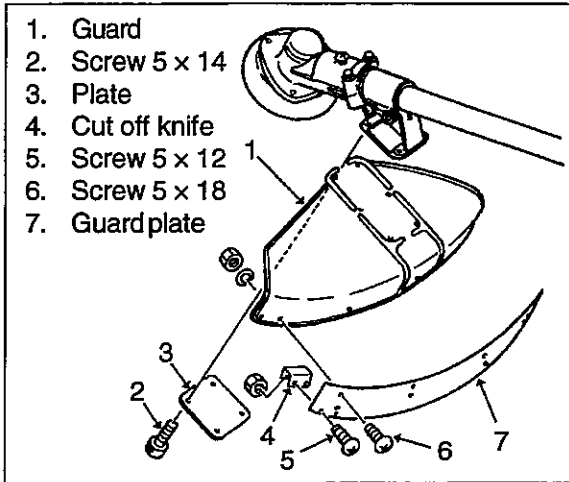

This machine SRM-3550 U-handle Version is available for nylon line cutting use.

INSTALLING GUARD

- Move guard backward (towards the operators) to align the bracket with nylon line cutter position mark on the guard.
- Fit guard plate on the guard and tighten four M 5 x 14 screws and nuts. Use top holes of guard plate to have maximum guard height.
- Fit cut off knife on the guard plate and tighten two M 5 x 12 screws and nuts.

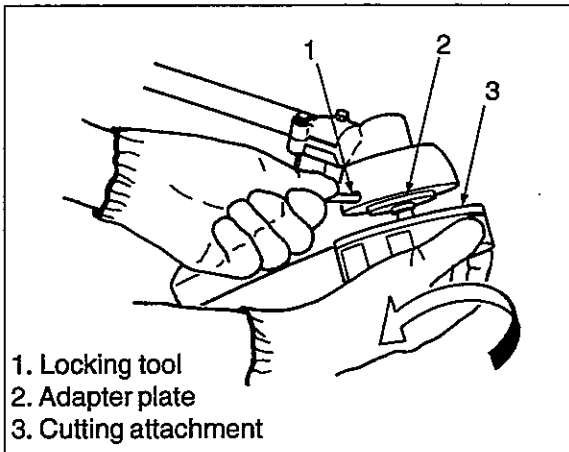

INSTALLING NYLON LINE CUTTING ATTACHMENT

1. Align hole in adapter plate with hole in blade retainer and install locking tool.
2. Thread cutting attachment onto shaft (turning it counter clockwise) until it is tight.
3. Remove locking tool.

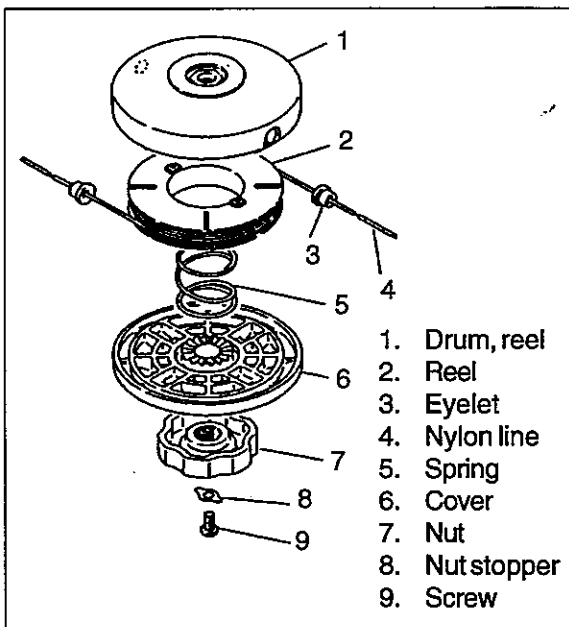

NYLON LINE CUTTING ATTACHMENT

Type : SRAH-200

Thread: Left-hand thread M 10 x 1.25 pitch

ADJUSTING NYLON LINE

- Loosen nut (7) about 1 or 1/2 turn clockwise as shown.
- Pull nylon line (4) out about 12 cm.
- Turn cover (6) clockwise to rewind nylon line if necessary.
- After adjusting nylon line length, tighten nut (7) securely clockwise.
- Cut off knife on the guard adjusts cutting swath to 40 cm automatically by cutting nylon lines evenly when attachment starts rotating.
- When operating with less than maximum cutting swath (40cm), cut two nylon lines in equal lengths.

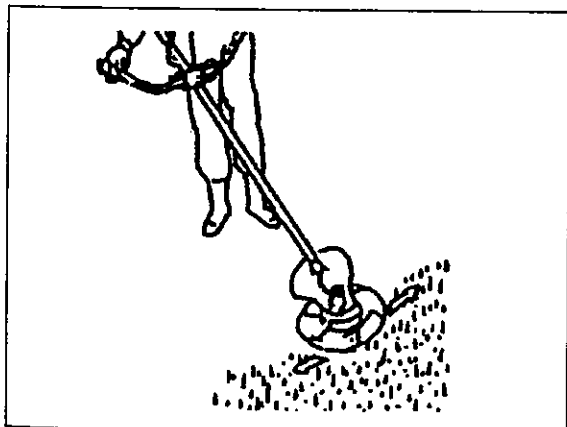
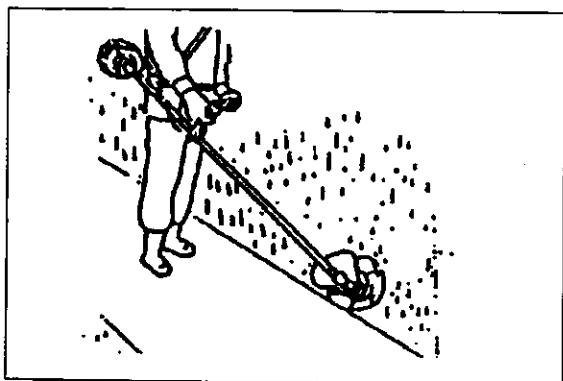
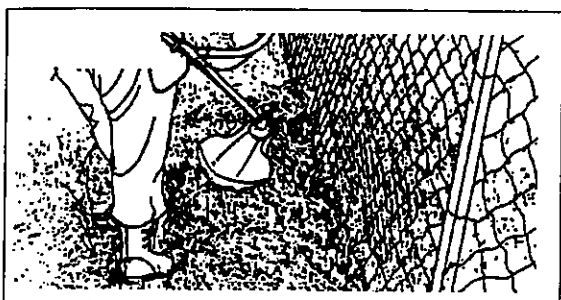
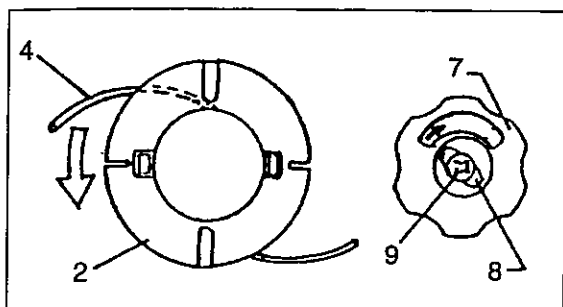
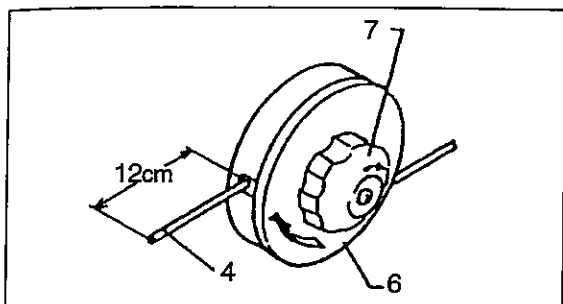

INSTALLING NEW NYLON LINE

- Remove screw (standard thread) (9) and nut stopper (8).
- Remove nut (7).
- Take out reel (2).
- Insert the end into fixing hole and wind nylon line (4) counterclockwise as shown.
- Assemble removed parts in the reverse order to the above steps.

CAUTION

Use only flexible, non-metallic line recommended by ECHO.

OPERATING NYLON LINE CUTTING ATTACHMENT

TRIMMING

The nylon line will allow you to trim along walls and fence lines.

Always try to trim from right to left, walking behind the unit and parallel to the wall or fence, thus deflecting debris away from the operator.

EDGING

The nylon line is intended only to cut grass and should not be used to cut a normal edging trench along stone or concrete driveways etc.

Tilt the unit vertically as illustrated and use only the line tip to remove unwanted growth.

MOWING

The nylon line will effectively mow large areas of heavy grass and/or weeds.

Use the standard 13~15 cm of line and operate at full throttle.

When mowing cultivated areas such as lawns hold the cutter head parallel to the ground to avoid scalping.

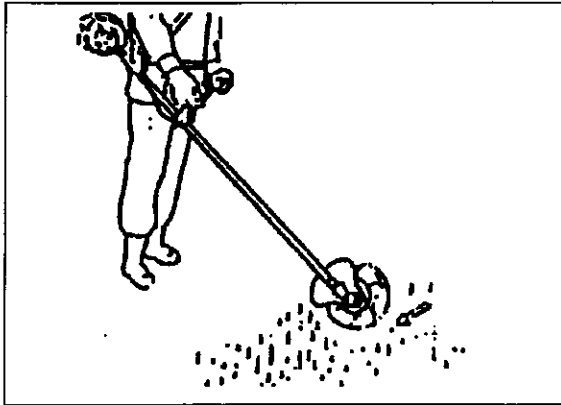

SCALPING

The cleaning of weeds and grass down to the earth can be accomplished very easily with the nylon line.

Scalping around trees and bushes is particularly effective, but care should be exercised not to bruise the bark of young and sensitive growth. In flower beds, always remember that the nylon line will cut in a complete circle to avoid cutting flowers instead of weeds.

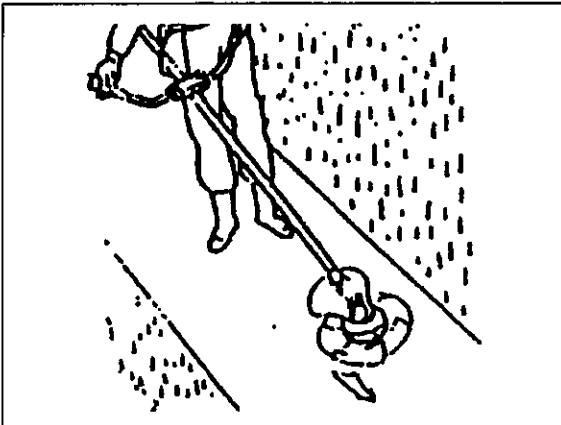

SWEEPING

Sweeping grass and other debris from a hard surface can be done very quickly.

STORAGE

LONG TERM STORAGE (Over 60 Days)

Do not store your unit for a prolonged period of time (60 days or longer) without performing protective storage maintenance which includes the following:

1. Store unit in a dry, dust free place, out of the reach of children.

WARNING  **DANGER**
DO NOT STORE IN ENCLOSURE WHERE
FUEL FUMES MAY ACCUMULATE OR
REACH AN OPEN FLAME OR SPARK.

2. Place ignition switch in STOP position.
3. Remove accumulation of grease, oil, dirt and debris from exterior of unit.
4. Perform all periodic lubrication and services that are required.

5. Tighten all the screws and nuts.

6. Drain the fuel tank completely and pull the starter handle several times to remove fuel from the carburettor.

7. Remove the spark plug and pour 1/2 table-spoon of fresh, clean, two-stroke engine oil into the cylinder through the spark plug hole.

A. Place a clean cloth over the spark plug hole.

B. Pull the recoil starter handle 2 ~ 3 times to distribute the oil inside the engine.

C. Observe the piston location through the spark plug hole. Pull the recoil handle slowly until the piston reaches the top of its travel and leave it there.

8. Install the spark plug (do not connect ignition cable).















NOTE

For future reference, you should keep this operator's manual.

SPECIFICATIONS

		SRM-3550(U)
Masses		
Unit without cutting attachment, empty tank	kg	7.2
Unit with specified cutting attachment, empty tank	kg	7.7
Unit with specified cutting attachment, full tank	kg	8.4
Volume		
Fuel tank	ℓ	0.95
Cutting attachment		
Usable cutting depth specified cutting attachment	mm	8
Specified blade diameter	mm	255
Specified blade thickness	mm	1.4
Number of cutting teeth		8
Blade centre hole diameter	mm	25
Blade rotational speed at maximum allowable engine speed	min ⁻¹	10,000
Gear ratio		
Gear ratio and lubrication		1 : 1.33 reduction and Shell Deipena or good quality lithium grease
Rotational direction of output shaft seen from above		
		Counter-clockwise
External dimensions		
length x width x height	mm	1,830 x 710 x 410
Engine		
Type		Air cooled two stroke single cylinder
Engine displacement	cm ³	34.4
Maximum shaft brake power, measured in accordance with ISO 8893	kW	1.06
Engine speed at maximum engine power	min ⁻¹	7,000
Recommended maximum engine speed	min ⁻¹	10,000
Recommended engine idling speed	min ⁻¹	2,800
Engine speed at beginning of clutch engagement	min ⁻¹	3,700
Carburettor		ZAMA diaphragm type
Ignition	rpm	Flywheel magneto - CDI system
Spark plug		NGKBP7A
Starter		Recoil starter
Clutch		Automatic centrifugal clutch
Fuel consumption		
Mixing ratio		Regular grade petrol 25 parts: 1 part (4%) An air cooled two stroke engine oil of a reputable brand name
Fuel consumption at maximum engine power	ℓ/h	0.85
Specified fuel consumption at maximum engine power	g/kWh	601
Sound pressure level		
L_{PAav}	dB(A)	90.9
Sound power level		
L_{WAav}	dB(A)	104
Vibration levels		
Idling	m/s ²	2.79
Racing	m/s ²	6.56

DECALS AND SYMBOLS

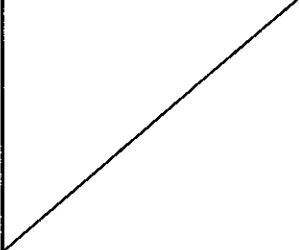
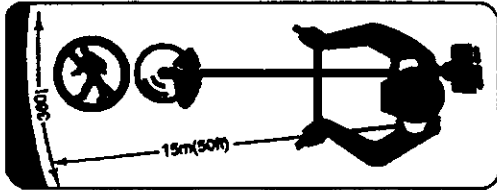
Symbol form / shape	Symbol description / application	Symbol form / shape	Symbol description / application
	Carefully read the operator's manual		Fuel and oil mixture
	Wear eyes, ears and head protection		Safety alert
	Emergency stop		Carburettor adjustment - Low speed mixture
	Warning! Thrown objects!		Carburettor adjustment - High speed mixture
	Usage without guard not permitted		Carburettor adjustment - Idle speed
	Usage of metal blades not permitted		The maximum speed of the cutting attachment shaft in rev/min
	Warning, side thrust		Circle and slash symbol means whatever is shown is prohibited
			Keep bystanders away 15 meters (50 feet)

DECLARATION "CE" OF CONFORMITY

The undersigned manufacturer:

KIORITZ CORPORATION
7-2 SUEHIROCHO 1-CHOME
OHME ; TOKYO 198
JAPAN

declares that the hereunder specified new unit:

GRASS-TRIMMER

Brand : **ECHO**
Type : **SRM-3550**

complies with:

- * the requirements of Directive **89/392/EEC**
(use of harmonized standard pr **EN 31806**).
- * the requirements of Directive **89/336/EEC**
(use of harmonized standards **EN 50081-1, EN 50082-1, EN 55014 & EN 55022**).

Tokyo,
September, 1st 1995

KIORITZ CORPORATION

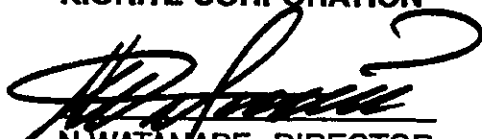
N. WATANABE, DIRECTOR

(GB)



KIORITZ CORPORATION

7-2, SUEHIROCHO 1-CHOME, OHME, TOKYO 198, JAPAN
PHONE: 0428-32-6118. FAX: 0428-32-6145.
TELEX: 2852070 KIORIT J



ECHO.



898615-52934
X750210-4802