

ECHO

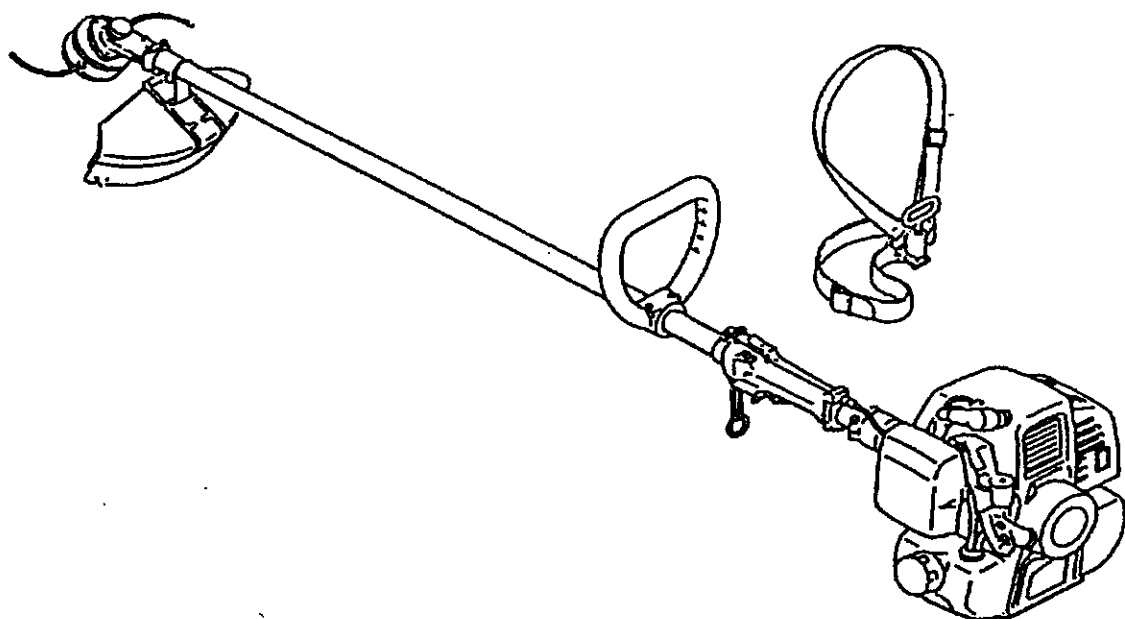

OPERATOR'S MANUAL

ECHO
GRASS TRIMMER
SRM-2010
Loop-handle version



CE

WARNING ▲ DANGER
READ INSTRUCTIONS CAREFULLY AND
FOLLOW RULES FOR SAFE OPERATION.
FAILURE TO DO SO COULD RESULT IN
SERIOUS INJURY.

INTRODUCTION

ECHO Grass Trimmers are lightweight, high-performance, petrol engined units designed for weed control and grass trimming in areas difficult to control by any other means. Loop-handle version of SRM-2010 is designed for occasional user.

This Manual provides the information necessary for assembly, operation and maintenance of your ECHO grass trimmer. You must read this Manual to understand the safe and effective operation of your ECHO product.

NOTE

This manual is for LOOP-HANDLE VERSION of SRM-2010.

CONTENTS

Introduction	1
Rules for safe operation	2
Description	12
Assembly	13
Installing Nylon line cutter	15
Operation	17
Maintenance and Care	21
Trouble shooting	25
Storage	26
Specifications	27
Decals and Symbols	28
Declaration of Conformity	29

Specifications, descriptions and illustrative material in this literature are as accurate as known at the time of publication. Illustrations may include optional equipment and accessories, and may not include all standard equipment.

WARNING  DANGER
FOR SAFE OPERATION READ INSTRUCTIONS CAREFULLY. OPERATOR'S MANUAL MUST BE READ FOR PROPER AND SAFE OPERATION.

 **THIS SYMBOL ACCOMPANIED BY THE WORDS WARNING AND DANGER CALLS ATTENTIONS TO AN ACT OR A CONDITION WHICH CAN LEAD TO SERIOUS PERSONAL INJURY OR DEATH.**

CAUTION
CAUTION indicates a potentially hazardous situation, if not avoided, may result in minor or moderate injury.

 **Circle and slash symbol means whatever is shown is prohibited.**

NOTE
 This enclosed message provides tips for use, care and maintenance of the unit.

RULES FOR SAFE OPERATION

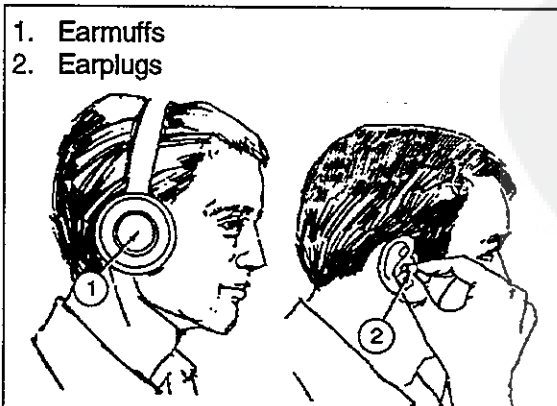
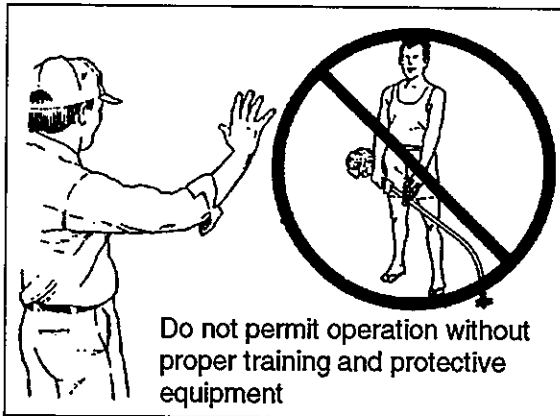

TRAINING

WARNING  **DANGER**
GRASS TRIMMERS AND BRUSHCUTTERS CAN THROW SMALL GRAVEL, STONE, GLASS, METAL OR PLASTIC OBJECTS AS WELL AS THE MATERIAL BEING CUT. READ THESE "RULES FOR SAFE OPERATION" WITH CARE. FOLLOW INSTRUCTIONS IN THE OPERATOR'S MANUAL.

Read the Operator's Manual carefully. Be thoroughly familiar with the controls and proper use of the unit.

Know how to stop the unit and shut off the engine.

Know how to unhook a harnessed unit quickly.

Never allow anyone to use the unit without proper instruction.

Be sure the operator wears the foot, leg, eye and hearing protection and has read this Manual.

EYE PROTECTION

The operator must wear eye protection not only against objects thrown by the unit, but also because eye infections can be caused by airborne dust, seeds and pollen.

Prescription glasses may be worn under the safety goggles.

Eye protection should also be worn by persons in the risk zone which extends beyond the danger zone.

HEARING AND EAR PROTECTION

Prolonged exposure to loud noise can cause impairment or loss of hearing.

Wear a suitable hearing protective device such as earmuffs or earplugs to protect against objectionable or uncomfortable loud noises.

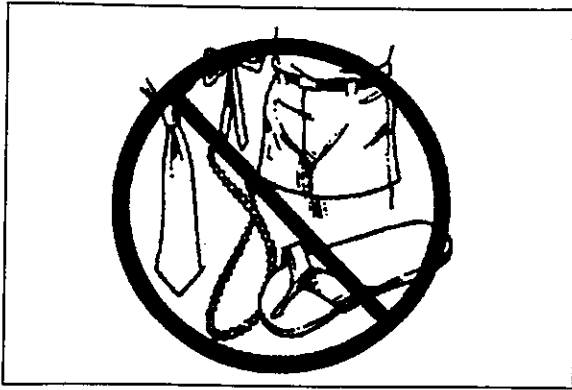

PROTECTIVE CLOTHING

Choose trousers, shirts and jackets that fit trimly and have no strings, frills or dangling straps which could catch on the unit or the underbrush. Do not wear ties, loose clothing or jewellery. Keep clothing buttoned or zipped up and shirt tails tucked in. Secure hair so it is above shoulder length.

The wearing of gloves offers some protection against contact with skin irritants such as poison ivy. Soft leather work gloves may also improve your grip.

FOOT AND LEG PROTECTION

Long trousers and sturdy shoes with non-slip soles are generally acceptable protection against objects thrown by a grass trimmer head.

ADDITIONAL PROTECTION

Hay fever (rhinitis) sufferers may purchase disposable masks at hardware or medical supply store to help reduce the intake of allergenic particles.

PREPARATION

WARNING DANGER

IN ADDITION TO HEAD, EYE AND EAR PROTECTION WEAR PROTECTIVE CLOTHES AND SHOES TO PROTECT YOUR FEET FROM THROWN OBJECTS, AND IMPROVE YOUR FOOTING ON SLIPPERY SURFACES. DO NOT WEAR TIES, JEWELLERY, OR LOOSE, DANGLING CLOTHING WHICH COULD BE CAUGHT IN THE UNIT. DO NOT WEAR OPEN-TOED FOOTWEAR, OR GO BARE-FOOT OR BARELEGGED, IN CERTAIN SITUATIONS YOU MUST ASSESS WHETHER TOTAL FACE AND HEAD PROTECTION MAY BE REQUIRED.

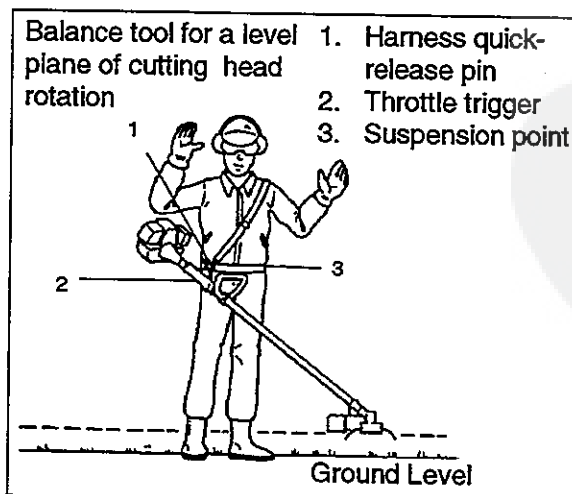
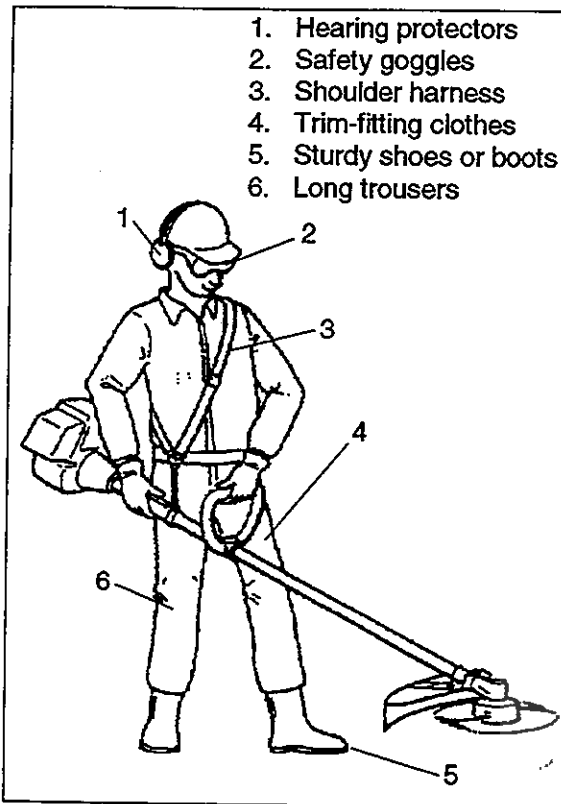

Use a shoulder harness when provided or when recommended in this manual. Adjust both harness and the suspension point on the unit so the unit hangs with the cutting attachment a few centimetres above ground level. The cutting attachment and guard should be level in all directions. Harness the unit on the right side as shown.

- Slide suspension point up and down the tube to find the right balance. Rotate the clamp to level the cutting attachment and guard. Lock in position. If the suspension point is a free-spinning type, the unit may tend to roll over sideways, however, you should still level the attachment and guard on the front-to-rear axis.

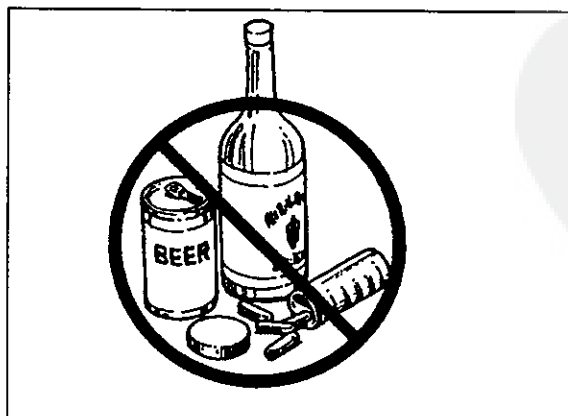
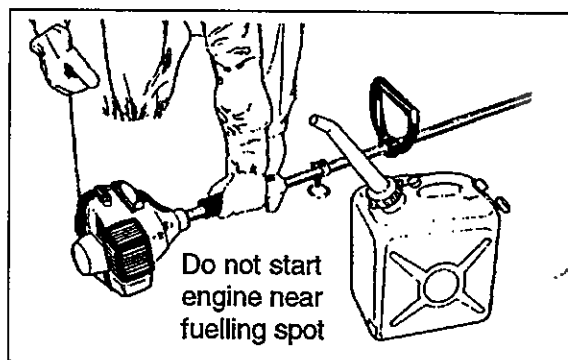
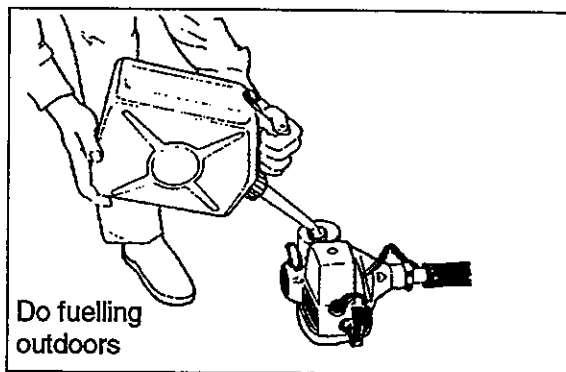
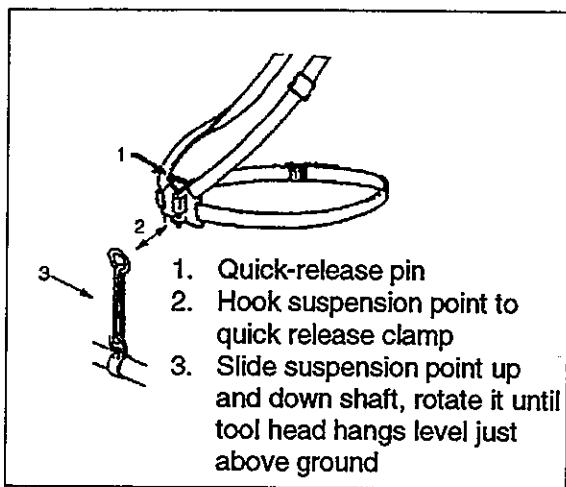

- b) Balancing and levelling, as above, may require relocation of the clamp and readjustment of the harness straps. Also, each type of cutting attachment and guard mounted on the unit may require balancing.

NOTE

A person's size can affect the balancing adjustment. Also the balancing procedure may not work with some ECHO units on some persons. If the procedure does not work for you, please ask your ECHO servicing dealer for assistance.

WARNING DANGER

ECHO TRIMMERS AND BRUSHCUTTERS ARE DESIGNED TO FIT A WIDE VARIETY OF BODY SIZES, BUT MAY NOT BE ADJUSTABLE FOR EXTREMELY TALL PERSONS.

DO NOT USE THE UNIT IF YOUR FEET CAN REACH THE CUTTING ATTACHMENT WHEN THE UNIT IS ATTACHED TO THE HARNESS.

Handle fuel with care. It is highly flammable.

- a) Use an appropriate type fuel container.
- b) Do not smoke or bring flame or sparks near fuel supplies.
- c) The fuel tank may be under pressure. Always loosen the fuel cap and wait for pressure to be equalized before removing the cap.
- d) Fill the fuel tank outdoors over bare ground and install the fuel cap securely. Do not pour fuel indoors.
- e) Wipe any spilled fuel off the unit. Then move at least 3 meters (10 feet) from the fuelling spot before starting the engine.
- f) Never refuel while the engine is still hot, or fuel a running engine.
- g) Do not store the unit with fuel in its tank, because a fuel leak could start a fire.

You should be in good mental and physical health. Do not operate if you are under the influence of alcohol or any medication or substance which could affect your vision, dexterity or judgement.

Inspect the area before using the unit. Remove objects the unit could throw. Remember where there are obstructions to be avoided.

Inspect the unit before using it. Perform only maintenance or adjustments for which the operator's Manual gives instruction. Do not try to repair the unit without proper instruction. The unit should be serviced only by trained ECHO dealer servicemen with the proper tools.

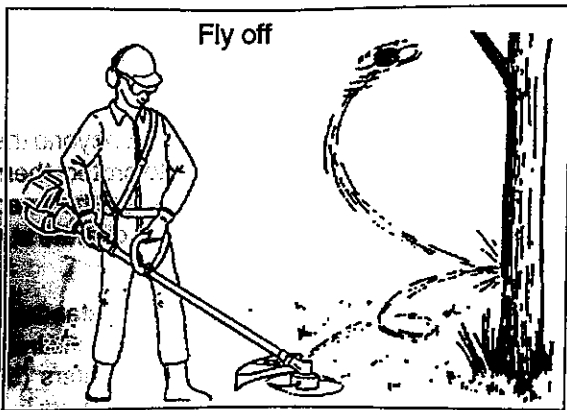

Be sure that:

- a) Engine does not leak fuel.
- b) Fasteners are tight, and none are missing.
- c) Silencer is in good condition.
- d) The unit has the proper equipment-guard, handles, harness, etc.-for the cutting attachment to be used.
- e) If used on the unit, the cutting attachment is properly tightened.

WARNING  DANGER
IMPROPER FIT WILL RESULT FLY OFF THE CUTTING ATTACHMENT.
NEVER START THE ENGINE IF THE POWER TRANSMISSION SHAFT IS NOT IN PLACE TO PREVENT THE ENGINE FROM OVERSPEEDING OR THE CLUTCH FROM FLYING APART.

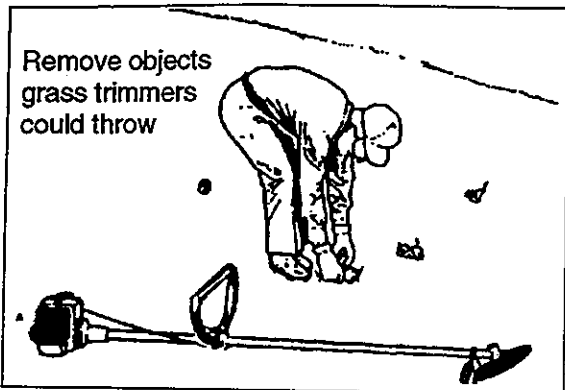

GENERAL OPERATION

Do not run the engine indoors, or where there is poor ventilation. Engine fumes contain deadly poisonous carbon monoxide.

Lay the unit down on a clear area and set the controls for starting. Be sure the cutting attachment cannot contact the ground or any obstruction.

Hold the unit firmly down so you will not lose control during starting. Do not start the unit in the air, or from the harness. The unit could swing into your leg or an obstruction if you lose control.

Do not raise the cutting attachment above knee height. If raised higher, the cutting attachment will be more directly in line with your face. Thrown objects may hit your face and eyes.

Wear the recommended foot, leg, head, eye and hearing protection at all times during operation. Also assess the job to be done, and whether other types of protection may be necessary.

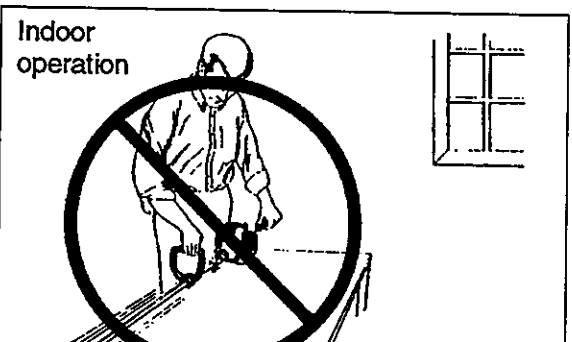
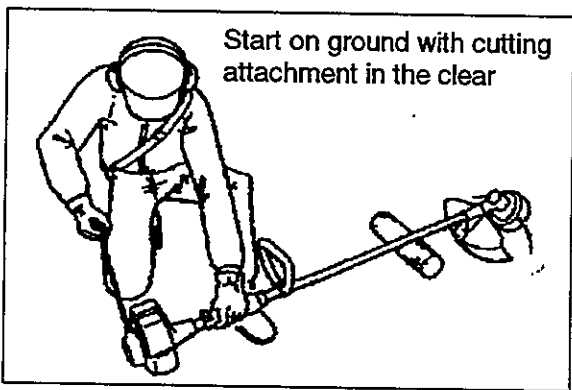

Never operate the unit without the proper guards and other protective devices.

Never operate the unit without good visibility and

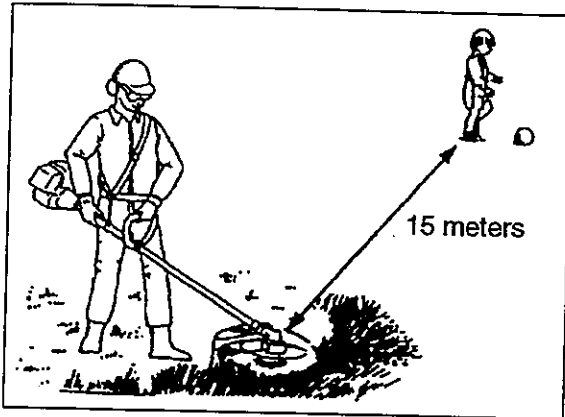

Do not allow anyone to enter the operating **DANGER ZONE** with you. The danger zone is an area of 15 meters (50 feet) in radius.

Insist that persons in the **RISK ZONE** beyond the danger zone wear eye protection to protect them from thrown objects. If the unit must be used where there are unprotected people, operate at a low throttle speed to reduce the risk.

Ensure that there are no children, bystanders, and pets in the work area. Keep all children, bystanders and helpers outside 15 meters (50 feet) radius for brushcutters/grasstrimmers.

If you are approached, stop the engine and cutting attachment immediately. Keep your hands and body away from silencer to prevent heat injury while the engine is hot.

Shut down immediately if the unit starts to shake or vibrate.

A sudden vibration is a sign there may be dangerous trouble, such as a broken flywheel, clutch or cutting attachment, or loose parts.

Do not use the unit until the problem has been properly diagnosed and corrected.

When the unit is turned off, make sure the cutting attachment has stopped before the unit is set down.

A cutting attachment can injure while it continues to spin after the engine is stopped or throttle control is released.

If the cutting attachment rotates after the engine returns to idle, carburettor adjustment is required. You can follow this operator's manual to make the adjustment yourself, or have the carburettor adjusted by your ECHO dealer.

All maintenance and adjustments given in the operator's manual should be performed by you or your ECHO servicing dealer on a timely basis. All required service or repairs must be done only by the ECHO servicing dealer. Never attempt to use an incomplete machine or one fitted with unauthorized modification.

Always use both hands on the handles. Do not operate one-handed.

Always hold the unit with the fingers and thumbs encircling the handles.

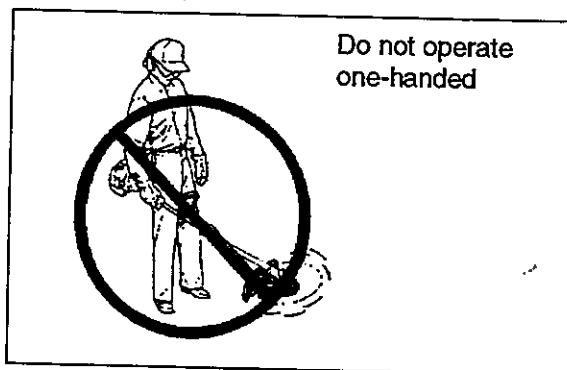
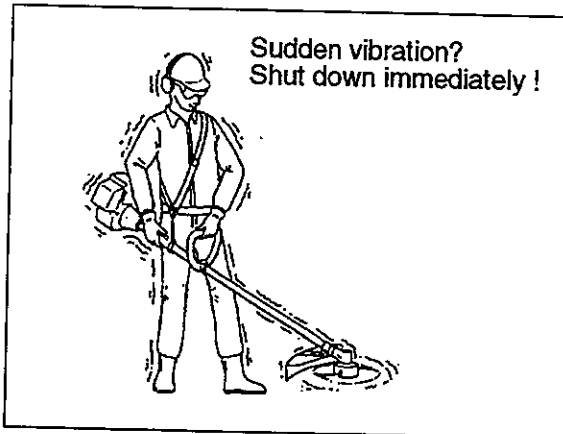

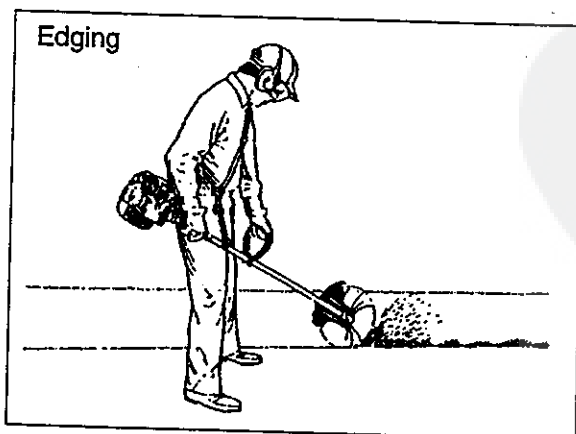
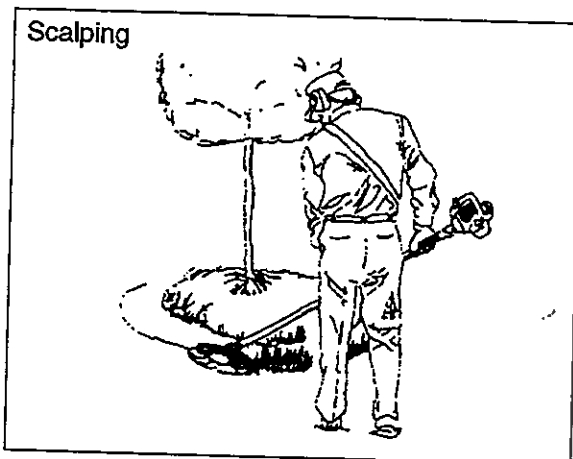
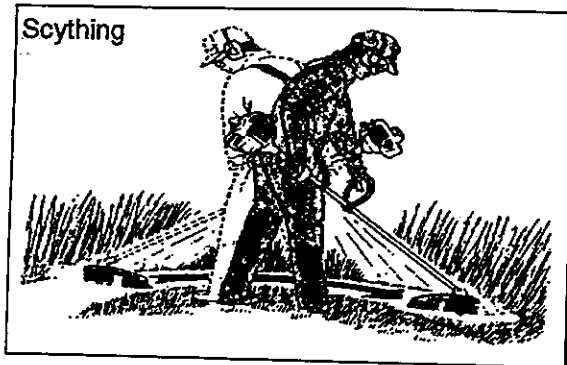
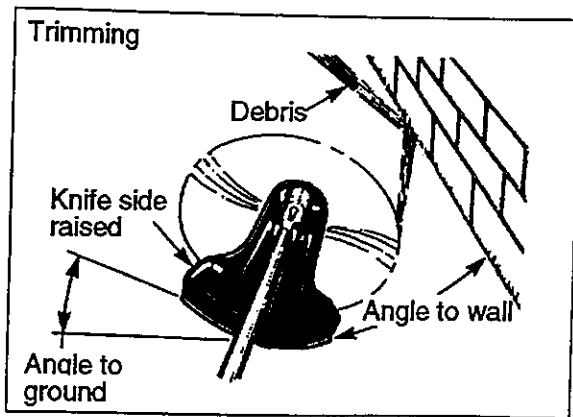

The basic cutting actions pictured are:

Trimming, scything, scalping and lawn edging.

These actions are as follows:

TRIMMING : This is feeding the trimmer carefully into the material you wish to cut. Tilt the head slightly to direct the debris away from you. If cutting up to a barrier such as a fence, wall or tree, approach from an angle where any debris ricocheting off the barrier will fly away from you. Move the line head or line disc slowly until the grass is cut right up to the barrier, but do not jam (overfeed) the line into the barrier. If trimming up to wire mesh or chain link fencing, be careful to feed only up to the wire. If you go too far, the line will snap off around the wire.

Trimming can be done to cut through weed stems one at a time. Place the nylon line cutter near the bottom of the weed never high up, which could cause the weed to chatter and catch the line. Rather than cut the weed right through, just use the very end of the line to wear through the stem slowly.

SCYTHING : This is the cutting or mowing of large grassy areas by sweeping or swinging the trimmer in a level arc. Use a smooth, easy motion. Do not try to hack or chop down the grass. Tilt the line head or line disc to direct the debris away from you on the scything stroke. Then return without cutting grass for another stroke. If you are well protected and do not care whether some debris is thrown in your direction, you may scythe in both directions.

SCALPING and EDGING : Both of these are done with the line head or line disc tilted at a steep angle. Scalping is removing top growth, leaving the earth bare. Edging is trimming the grass back where it has spread over a pavement or driveway. During both edging and scalping, hold the unit at a steep angle in a position where the debris, and any dislodged dirt and stone, will not come back towards you even if it ricochets off the hard surface.

Although the pictures show how to edge and scalp, every operator must find for himself the angles which suit his body size and cutting situation.

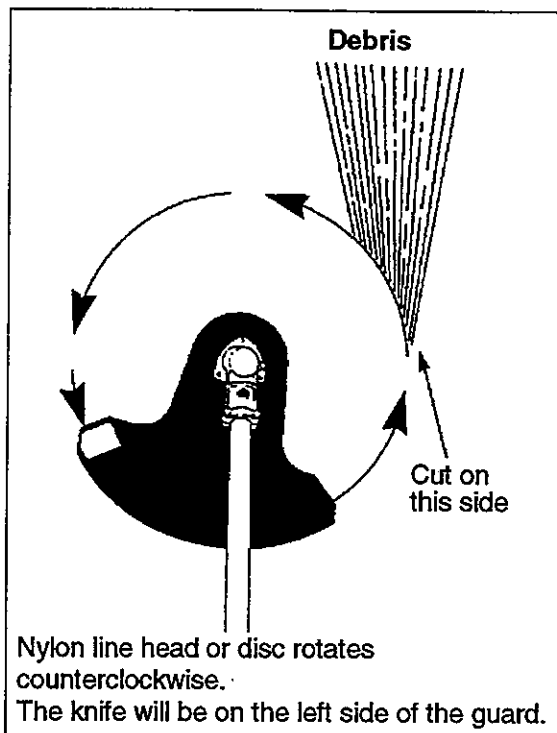

For nearly all cutting, it is good to tilt the nylon cutter so that contact is made on the part of line circle where the line is moving away from you and the guard (See appropriate picture.) This results in the debris being thrown away from you.

Tilting the head to the wrong side will shoot the debris toward you. If the nylon line cutter is held flat to the ground so that cutting occurs on the whole line circle, debris will be thrown at you, drag will slow the engine, and you will use up a lot of line.

WARNING  **DANGER**
USE ONLY FLEXIBLE, NON-METALLIC
LINE RECOMMENDED BY ECHO.

WARNING  **DANGER**
USE EXTREME CAUTION WHEN OPER-
ATING OVER BARE SPOTS AND
GRAVEL, BECAUSE THE LINE CAN
THROW SMALL ROCK PARTICLES AT
HIGH SPEEDS. THE GUARD ON THE
UNIT CANNOT STOP OBJECTS WHICH
BOUNCE OR RICOCHET OFF HARD
SURFACES.

Always wear proper eye protection against thrown objects. Objects can bounce up at you from the ground under the guard, or ricochet off any nearby hard surface.

Do not trim at high speed near roadways when there is traffic, or in places where there are pedestrians. If you must trim where people are in the zone of risk use a much lower or reduced speed, by using a partial trigger setting. Do not use full throttle.

Do not push the line into tough weeds, trees, or wire fences. Pushing the line into chicken wire, chain link fencing or thick brush can result in snapped-off line ends being hurled back at the operator. The proper way is to cut right up to a barrier, such as any of those mentioned, but never run the line into or through the obstruction. Do not cut closely to obstruction or barrier.

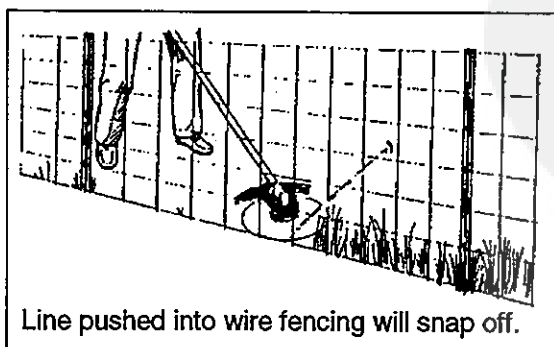
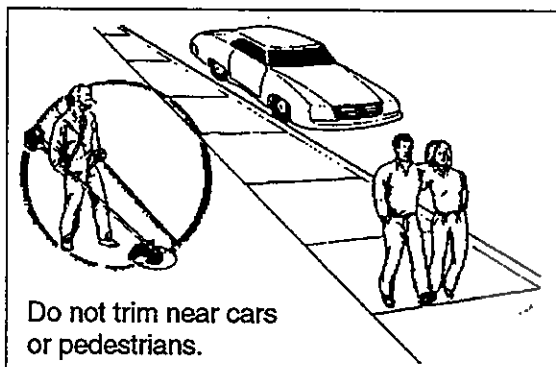

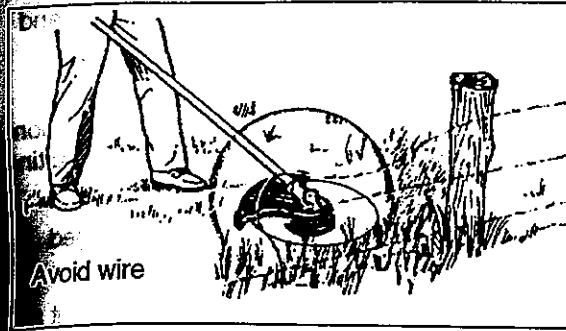

Avoid nylon line contact with broken wire fencing. Pieces of wire broken off by the trimmer can be hurled at high speeds.

WARNING **DANGER**
DO NOT TRIM IN ANY AREA WHERE THERE ARE BROKEN STRANDS OF FENCING WIRE. REMOVE THE BROKEN PIECES OF WIRE, OR GIVE THE AREA WIDE BERTH. WEAR PROPER SAFETY PROTECTION. DO NOT CUT WHERE YOU CANNOT SEE WHAT THE CUTTING DEVICE IS CUTTING.

WARNING **DANGER**
ALWAYS STOP THE ENGINE WHEN A CUTTING ATTACHMENT JAM OCCURS. DO NOT ATTEMPT TO REMOVE AN OBJECT CAUSING A JAM IF THE ENGINE IS RUNNING. INJURY CAN OCCUR IF A JAM IS REMOVED AND THE CUTTING ATTACHMENT SUDDENLY STARTS.

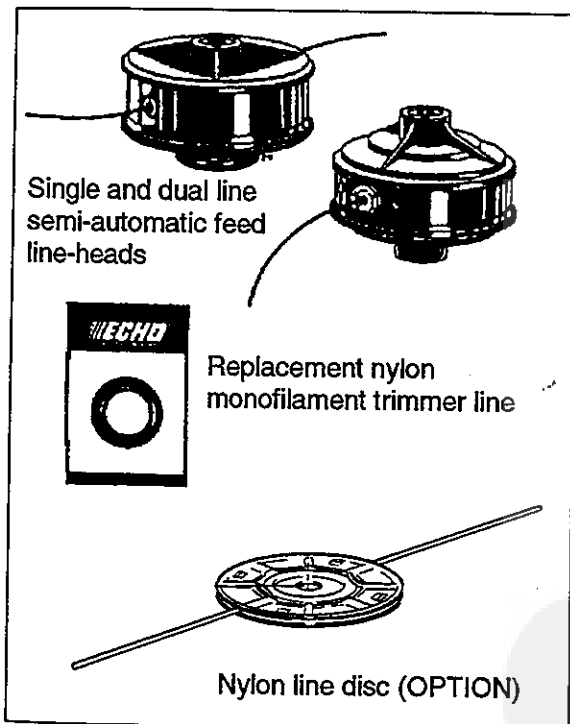

USE CORRECT CUTTING ATTACHMENT

WARNING **DANGER**

- SERIOUS INJURY MAY RESULT FROM THE IMPROPER USE OF CUTTING ATTACHMENT. READ AND COMPLY WITH ALL SAFETY INSTRUCTIONS LISTED IN THIS MANUAL.
- USE ONLY CUTTING ATTACHMENTS RECOMMENDED BY ECHO.

WARNING **DANGER**
EXCESSIVE NYLON LINE BEYOND CUT OFF KNIFE COULD FLY OFF WHEN THE NYLON LINE CUTTER STARTS ROTATING AFTER ADJUSTMENT OF NYLON LINE LENGTH.

WARNING **DANGER**
USE ONLY NYLON LINE. DO NOT USE ANY TYPE OF METAL BLADE.

1. Quick-release pin
2. Pull out
3. Shaft tube

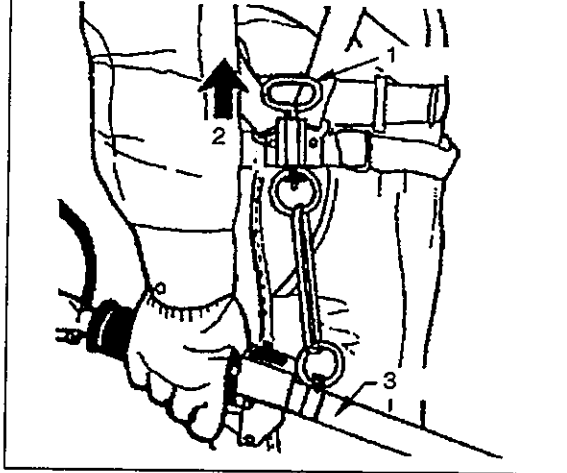

- Do not hit rocks, stones, tree stumps, and other foreign objects with the cutting attachment.
- If cutting attachment strikes an obstruction, stop engine immediately and inspect cutting attachment for damage.
- Do not operate with a worn or damaged cutting attachment.
- Do not run engine at full throttle without a load.
- Remove all foreign objects from work area.
- Do not operate grasstrimmer without shoulder harness and guard.
- In case of an emergency, use quick-release pin on harness to free yourself from unit.
- Keep bystanders 15 meters (50 feet) from operator.
- Always carry unit with the engine stopped and the HOT silencer away from your body.
- Always stop the unit when transporting, storing and servicing the unit.

WARNING  **DANGER**
BEYOND THE 15 METERS (50 FEET)
DANGER ZONE THERE STILL MAY BE
RISK OF EYE INJURY FROM THROWN
OBJECTS. THE RISK DIMINISHES WITH
DISTANCE. BUT EYE PROTECTION
SHOULD BE CONSIDERED FOR EVERY-
ONE IN THE ZONE OF RISK.

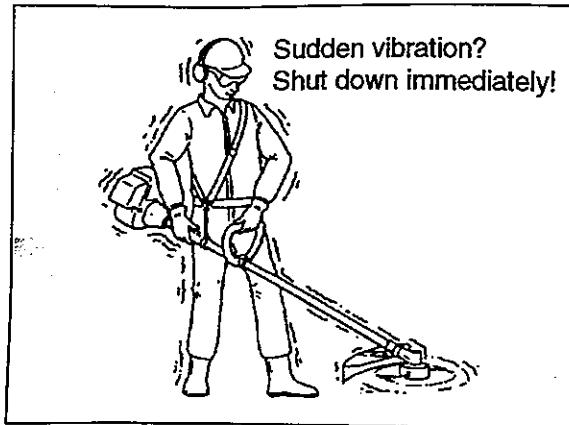

VIBRATION AND COLD

It is believed that a condition called Raynaud's Phenomenon which affects the fingers of certain individuals may be brought about by exposure to vibration and cold. Exposure to vibration and cold may cause tingling and burning, followed by loss of colour and numbness in the fingers.

The following precautions are strongly recommended because the minimum exposure which might trigger the ailment is unknown.

- Keep your body warm, especially the head and neck, feet and ankles, and hands and wrists.
- Maintain good blood circulation by performing vigorous arm exercises during frequent work breaks, and also by not smoking.
- Limit the number of hours of operation. Try to fill each day with jobs where operating the trimmer or other hand-held power equipment is not required.
- If you experience discomfort, redness and swelling of the fingers, followed by whitening and loss of feeling, consult your physician before exposing yourself further to cold and vibration.

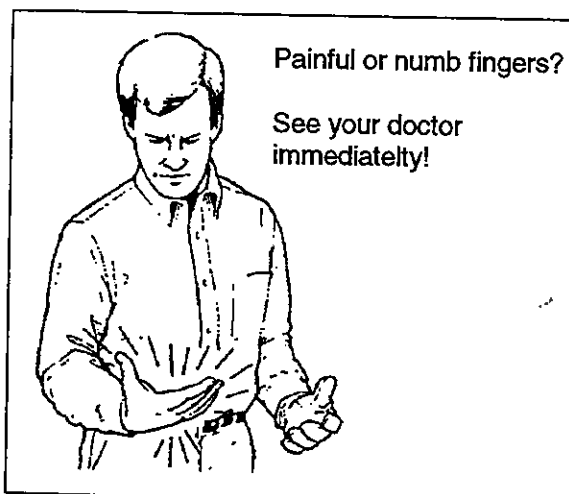

REPETITIVE STRESS INJURIES

It is believed that overusing the muscles and tendons of the fingers, hands, arms and shoulders may cause soreness, swelling, numbness, weakness and extreme pain to the areas just mentioned. Certain repetitive hand activities may put you at a high risk for developing a repetitive stress injury (RSI).

To reduce the risk of RSI, do the following:

- Avoid using your wrist in a bent, extended or twisted position.
- Take periodic breaks to minimize repetition and rest your hands. Reduce the speed and force in which you do the repetitive movement.
- Do exercises to strengthen hand and arm muscles.
- See a doctor if you feel tingling, numbness or pain in your fingers, hands, wrists or arms. The sooner RSI is diagnosed, the more likely permanent nerve and muscle damage can be prevented.

DESCRIPTION

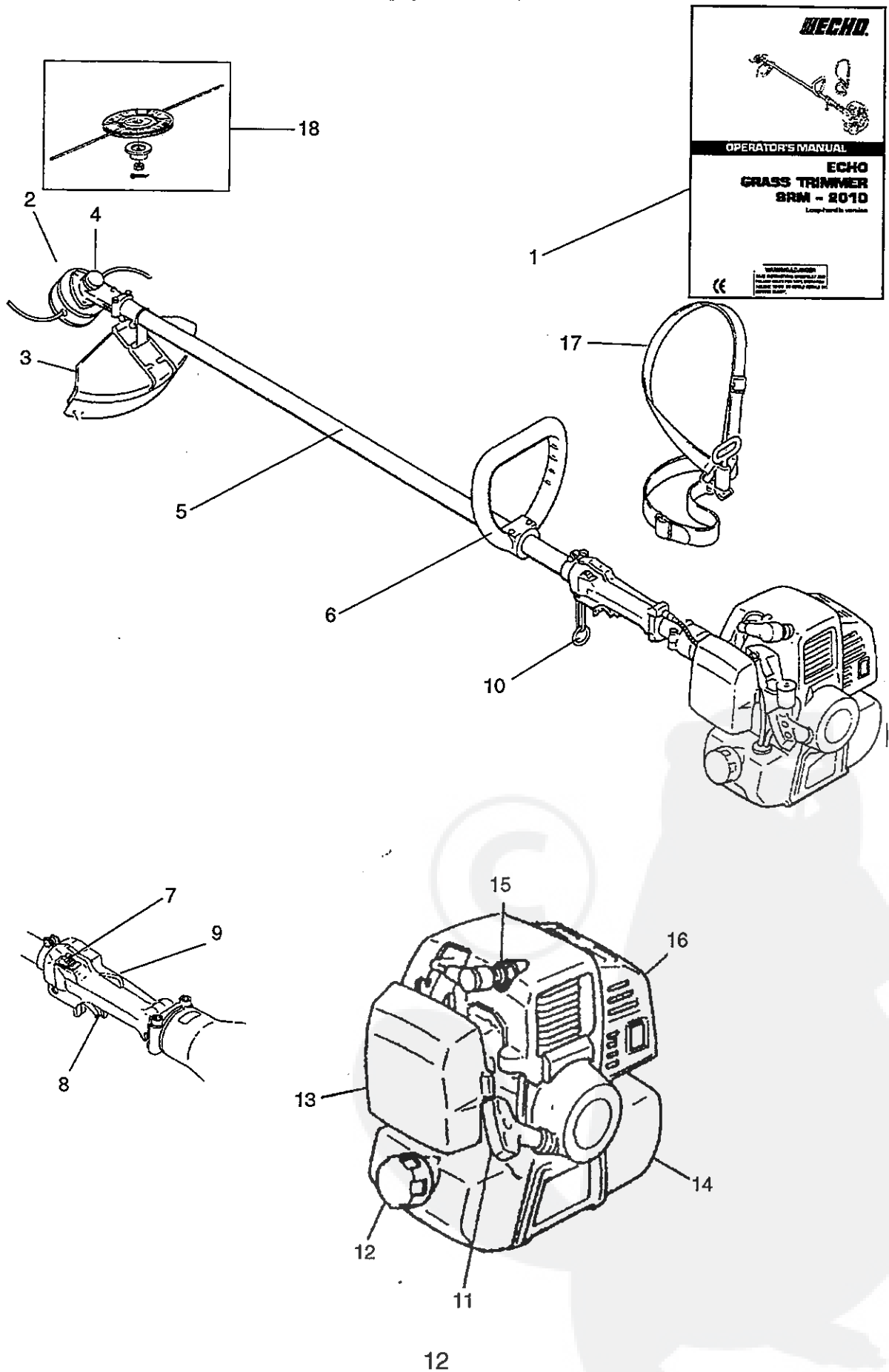

DESCRIPTION

- 1 OPERATOR'S MANUAL** Included with unit. Read before operation and keep for future reference to learn proper, safe operating techniques.
- 2 CUTTING ATTACHMENT** Nylon line head for cutting grass and weed.
- 3 CUTTING ATTACHMENT GUARD** Device to protect the operator from accidental contact with the cutting head and thrown objects.
- 4 ANGLE TRANSMISSION** Having two gears to change the angle of rotating axis.
- 5 SHAFT TUBE** Part of the unit that provides a casing for power transmission shaft.
- 6 LOOP-HANDLE** Light weight, suitable for Nylon line trimmer only.
- 7 IGNITION SWITCH** "Slide Switch" mounted on top of the Throttle Trigger Housing, move switch forward to RUN , backward to STOP position.
- 8 THROTTLE TRIGGER** Activated by the operator's finger for controlling the engine speed.
- 9 THROTTLE TRIGGER LOCKOUT** Locks throttle trigger in the idling position until you have a proper grip with your right hand around the handle.
- 10 SUSPENSION POINT** Device on which the harness can be hooked.
- 11 STARTER HANDLE** Pull handle to start the engine.
- 12 FUEL TANK CAP** Covers and seals fuel tank.
- 13 AIR CLEANER COVER** Covers and seals air filter.
- 14 FUEL TANK** Contains fuel and fuel filter.
- 15 SPARK PLUG**
- 16 SILENCER COVER** Cover the silencer not to make operator touch to hot surface of silencer.
- 17 SHOULDER HARNESS** An adjustable strap to suspend unit.
- 18 RETAINING PARTS** Optional Attachment such as Nylon line disc.

ASSEMBLING

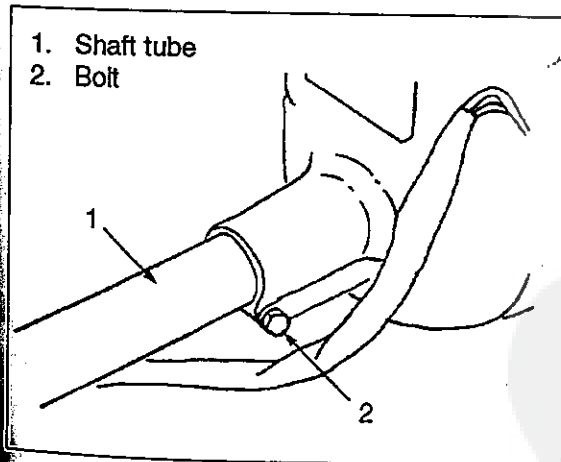

SHAFT TUBE

1. Stand engine upright on a level surface.
2. Loosen the bolts at shaft tube end of engine.
3. Carefully fit shaft tube to engine, making sure the power transmission shaft is correctly engaged.

NOTE

The line on the shaft tube must be in contact with the engine (arrow on shaft tube indicates line).

4. Rotate the shaft tube housing until bearing housing is in line with the engine.
5. Tighten bolt.

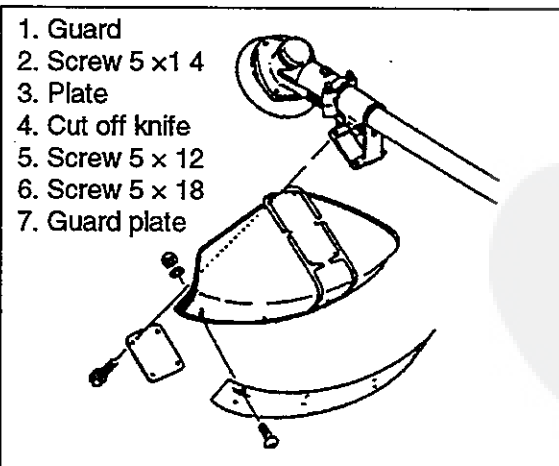
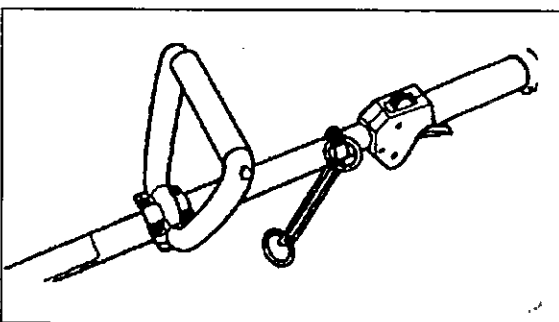
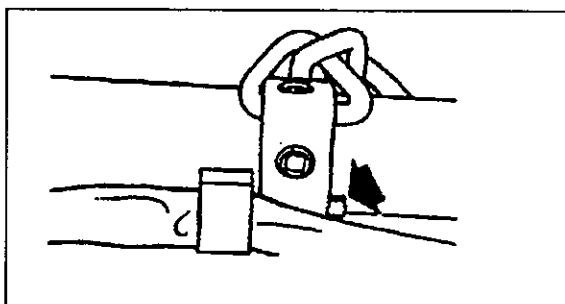
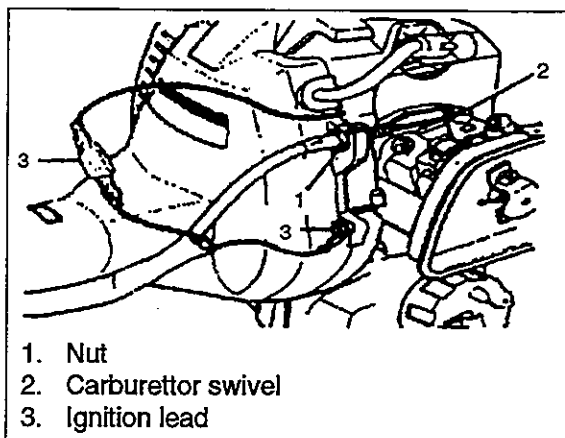

THROTTLE CABLE AND IGNITION LEADS

1. Close choke and remove air filter cover.
2. Loosen nut and place threaded cable housing in bracket slot. If there are flat washers between the two nuts, place one on each side of the bracket. Finger tighten nut .
3. Place inner cable in slot of carburettor swivel and tighten nut.
4. Check to make sure throttle operates freely, opens completely and returns to idle.
5. Connect ignition leads. This unit has one spade terminal pair and one ring terminal which is secured under fan cover screw.
6. Re-install air cleaner cover.

LOOP-HANDLE

1. Assemble loop handle and bracket to drive shaft loosely.
2. Position handle in comfortable operating position and tighten screws.

INSTALLATION OF GUARD

- Align the bracket with nylon line cutter position mark on the guard.
- Fit guard plate on the guard and tighten four 5 x 14 screws and nuts.
- Fit guard plate on the guard and tighten four 5 x 18 screws and nuts. Use top holes of guard plate to have maximum guard height.
- Fit cut off knife on the guard plate and tighten two 5 x 12 screws and nuts. For safe operation, never use the unit without guard fitted.

INSTALLING NYLON LINE CUTTER

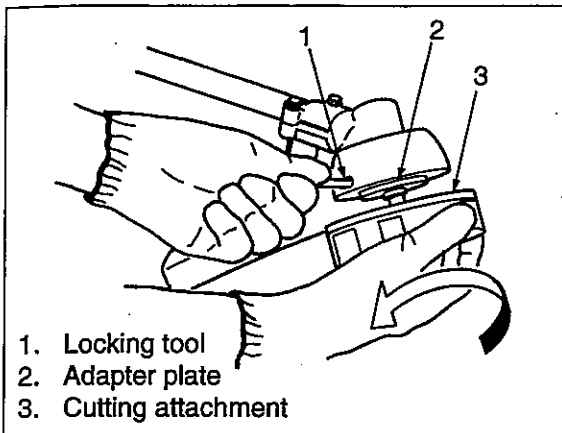

1. Locking tool
2. Adapter plate
3. Cutting attachment

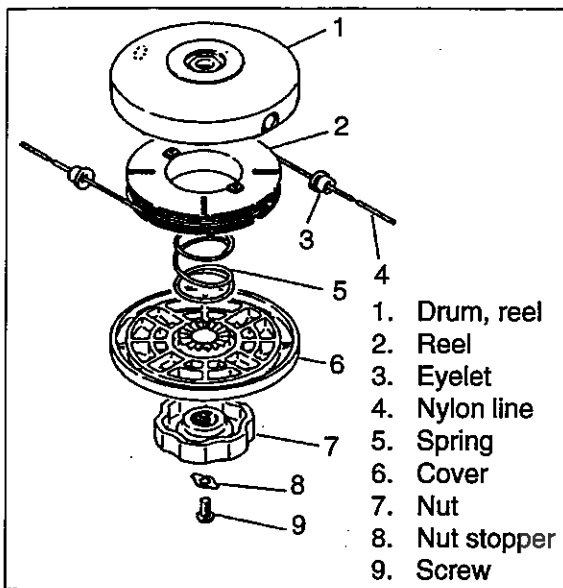

1. Drum, reel
2. Reel
3. Eyelet
4. Nylon line
5. Spring
6. Cover
7. Nut
8. Nut stopper
9. Screw

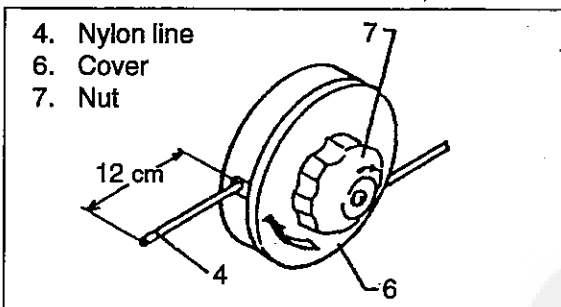

4. Nylon line
6. Cover
7. Nut

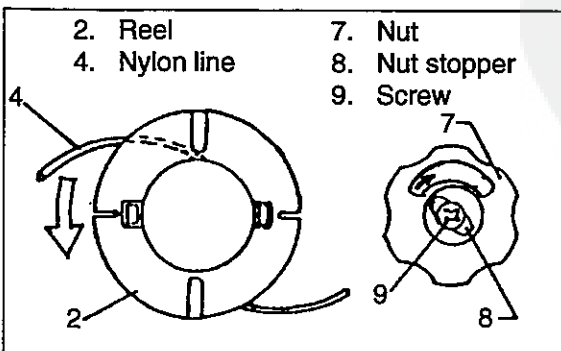

2. Reel
4. Nylon line
7. Nut
8. Nut stopper
9. Screw

INSTALLING NYLON LINE HEAD

1. Align hole in adapter with hole in blade retainer and install locking tool.
2. Thread cutting attachment onto shaft (turning it counter clockwise) until it is tight.
3. Remove locking tool.

NYLON LINE HEAD

Type : SRAH-200

Thread : Left-hand thread M 10 x 1.25 pitch

ADJUSTING NYLON LINE

- Loosen nut (7) about 1 or 1/2 turn clockwise as shown.
- Pull nylon line (4) out about 12 cm.
- Turn cover (6) clockwise to rewind nylon line if necessary.
- After adjusting nylon line length, tighten nut (7) securely clockwise.
- Cut off knife on the guard adjusts cutting swath to 40 cm automatically by cutting nylon lines evenly when attachment starts rotating.
- When operating with less than maximum cutting swath (40cm), cut two nylon lines in equal lengths.

INSTALLING NEW NYLON LINE

- Remove screw (standard thread) (9) and nut stopper (8).
- Remove nut (7).
- Take out reel (2).
- Insert the end into fixing hole and wind nylon line (4) counterclockwise as shown.
- Assemble removed parts in the reverse order to the above steps.

CAUTION

Use only flexible, non-metallic line recommended by ECHO.

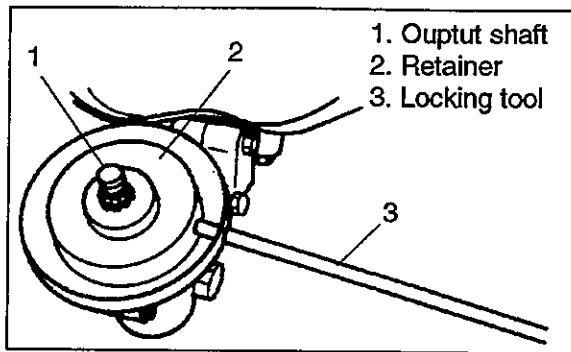

OPTION

INSTALLING NYLON LINE DISC (MH-2)

Use a locking tool to prevent the output shaft from turning during disc installation.

Install retainer, disc, lower retainer and nut finger tight.

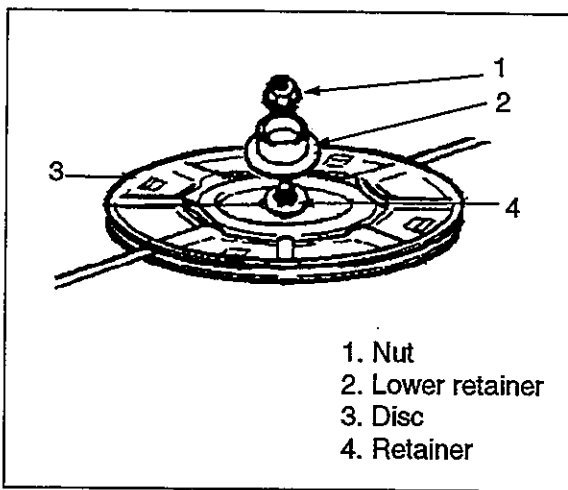

NOTE

Check to be sure the locking tool is fully engaged to prevent the output shaft from turning.

Tighten the nut (turn counterclockwise) using a socket wrench.

Secure the nut using a new split pin.

CAUTION

Wear gloves to reduce the risk of injury caused by contact with the edge.

INSTALLING NEW NYLON LINE

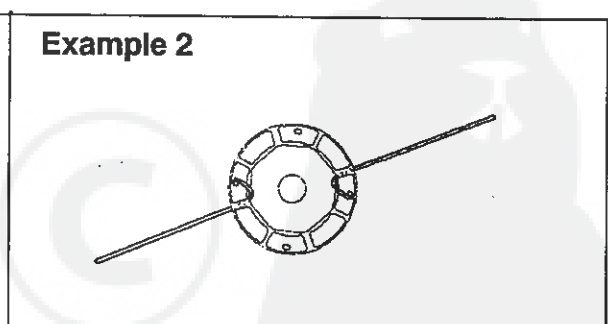
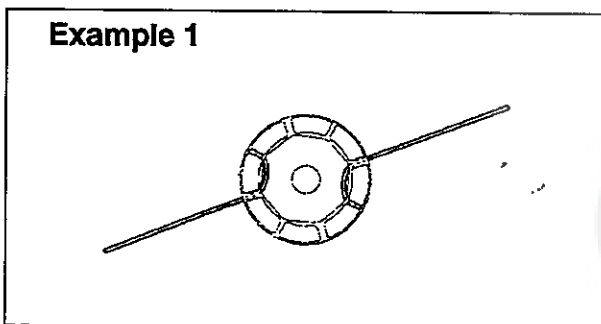

WARNING **DANGER**
USE ONLY NYLON LINE. DO NOT USE ANY TYPE OF METAL BLADE.

NOTE

Use only trimming attachments recommended in this manual. Retaining parts for nylon line disc are provided as standard with the unit.

OPERATION

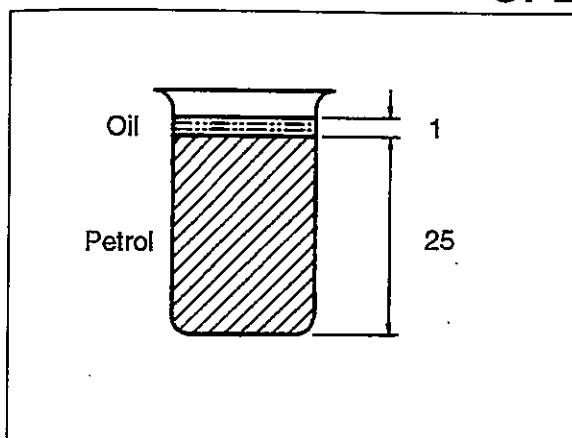

Fuel Mix Chart 25:1 (4%)

IMPERIAL		METRIC	
PETROL	OIL	PETROL	OIL
GAL.	FL.OZ.	LITRES	C.C.
1	6.4	4	160
2	12.8	8	320
5	32.0	20	800

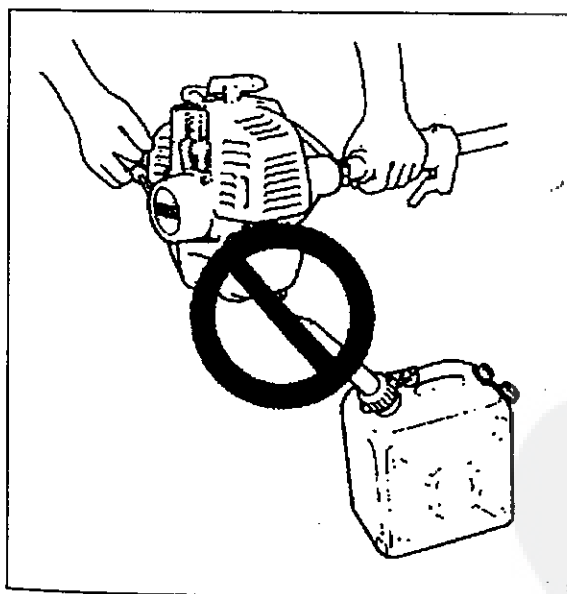

FUEL

- Fuel used for this model is a mixture of Regular grade petrol and a normal two stroke engine oil of a reputable brand name.
- Mixture ratio is petrol 25 parts : Oil 1 part.
- Fuel mixture at the ratio other than 25 : 1 may cause malfunction of the engine.
- Ensure mixture ratio is correct.

CAUTION

Stored fuel ages. Do not mix more fuel than you expect to use in thirty (30) days, ninety (90) days when a fuel stabilizer is added.

Stored two-stroke fuel may separate.

ALWAYS shake fuel container thoroughly before each use.

Do not mix directly in fuel tank.

HANDLING FUEL

- Never smoke or allow flame or sparks near fuel.
- Always fill the fuel tank outdoors.
- Never pour fuel indoors.
- Never refuel the engine when it is hot or running.
- Always use an approved, safe fuel container.
- After fuelling, always wipe away spilled fuel.
- Always move at least 3 meters (10 feet) away from the fuelling spot before starting the engine.
- Never store the unit with fuel in the tank a fuel leak could start a fire.

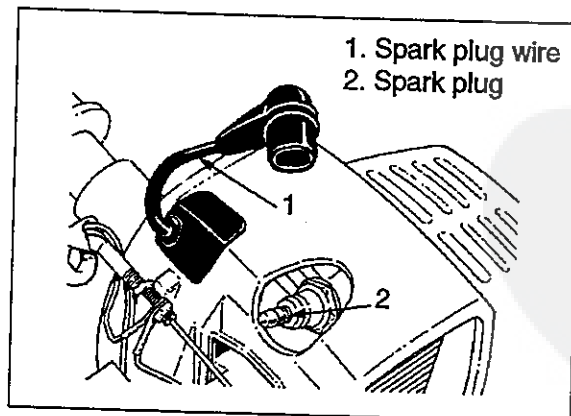
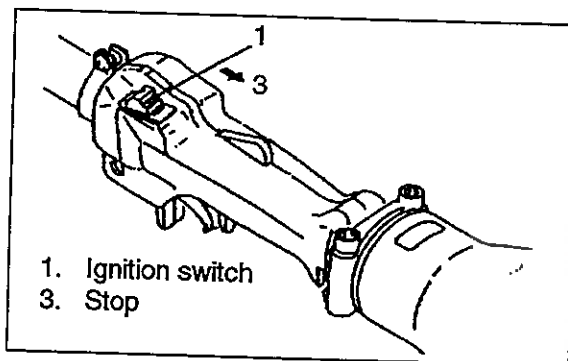
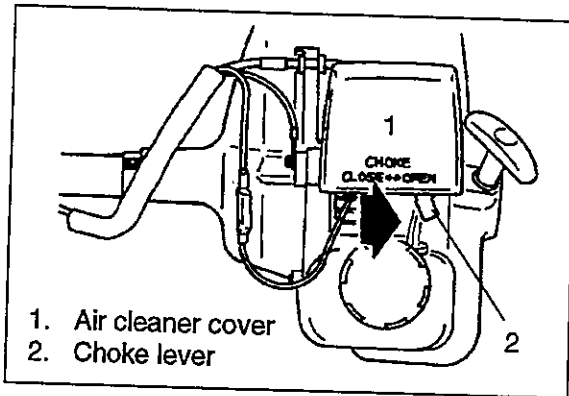
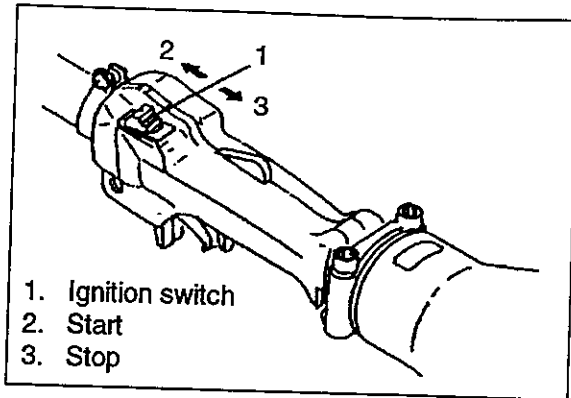

STARTING COLD ENGINE

WARNING  **DANGER**
WHEN ENGINE STARTS, THE CUTTING ATTACHMENT MAY ROTATE, EVEN WITH THROTTLE TRIGGER IN LOW-SPEED POSITION.

- Place ignition switch in START position.
- Move choke lever to CLOSED position.
- Pull starter rope until first firing sound.
- Open choke.
- Restart engine and allow to warm up.

NOTE

- Check unit for loose nuts, bolts and screws before starting.
- Always clear work area of debris before starting operation.
- Always hold the unit firmly on the ground.
- When pulling starter handle, use short pulls, 1/2 to 2/3 of rope length.
- Do not allow the starter handle to snap back against the housing.

STARTING WARM ENGINE

- Place ignition switch in START position.
- Move choke lever to OPEN position.
- If tank is not empty pull starter handle.
- If fuel tank is empty, refuel first and then pull starter handle.

NOTE

If engine does not start after 4 pulls, use Cold Starting Procedure.

STOPPING ENGINE

- Release throttle trigger and allow engine to idle.
- Place ignition switch in STOP position.

WARNING  **DANGER**
IF ENGINE DOES NOT STOP, CLOSE CHOKE TO STALL ENGINE. HAVE YOUR ECHO DEALER INSPECT AND REPAIR IGNITION SWITCH BEFORE USING THE UNIT.

Always disconnect the spark plug wire from the spark plug to ensure the engine cannot be started before you work on the unit or leave it unattended.

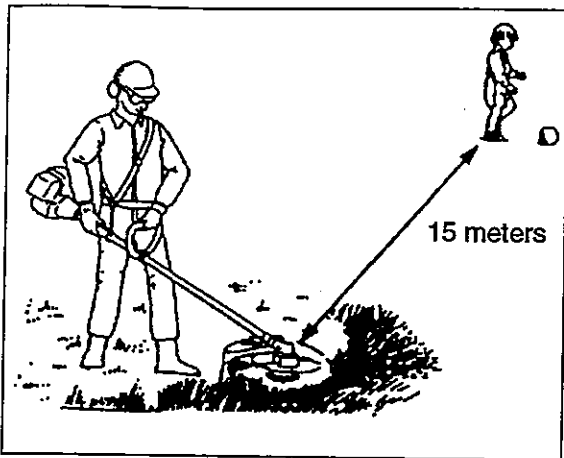

OPERATING THE UNIT

Spectators and fellow workers must be warned and children and animals prevented from coming near than 15 meters (50 feet) while the grasstrimmer is in use.

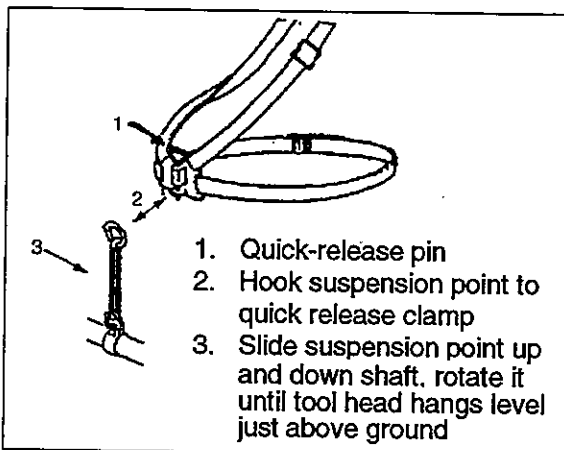

USING SHOULDER HARNESS

Place shoulder harness over left shoulder and adjust straps so the quick-release pin rests just below the waist.

Buckle waist belt. Belt should be snug.

Attach grasstrimmer to harness.

Check for correct adjustment by moving cutting attachment along ground. See Rules for Safe Operation for proper adjustment.

Re-adjust position of suspension point if necessary.

WARNING DANGER
IN CASE OF AN EMERGENCY, USE QUICK-RELEASE PIN ON HARNESS TO FREE YOURSELF FROM UNIT.

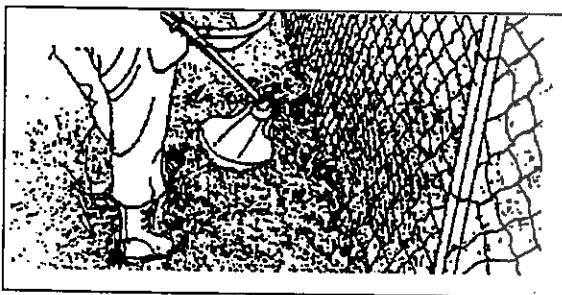

TRIMMING

The nylon line will allow you to trim along walls and fence lines.

Always try to trim from right to left, walking behind the unit and parallel to the wall or fence, thus deflecting debris away from the operator.

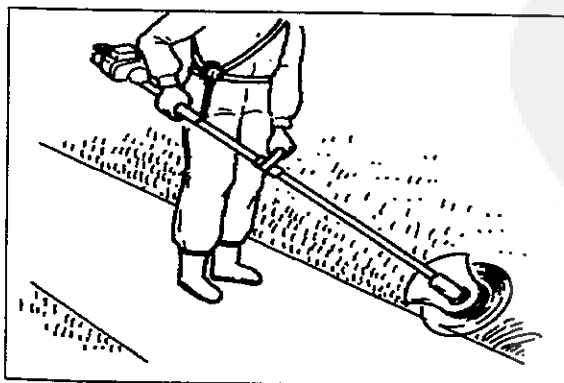

EDGING

The nylon line is intended only to cut grass and should not be used to cut a normal edging trench along stone or concrete driveways etc. Tilt the unit vertically as illustrated and use only the line tip to remove unwanted growth.



MOWING

The nylon line will effectively mow large areas of heavy grass and/or weeds. Use the standard 13-15 cm of line and operate at full throttle. When mowing cultivated areas such as lawns hold the cutter head parallel to the ground to avoid scalping.



SCALPING

The cleaning of weeds and grass down to the earth can be accomplished very easily with the nylon line. Scalping around trees and bushes is particularly effective, but care should be exercised not to bruise the bark of young and sensitive growth. In flower beds, always remember that the nylon line will cut in a complete circle to avoid cutting flowers instead of weeds.

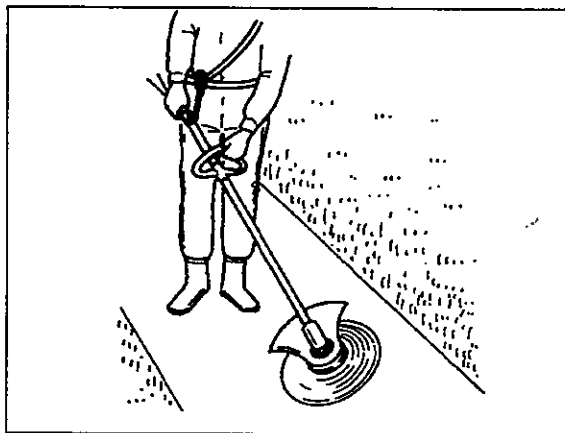

SWEEPING

Sweeping grass and other debris from a hard surface can be done very quickly.

MAINTENANCE AND CARE

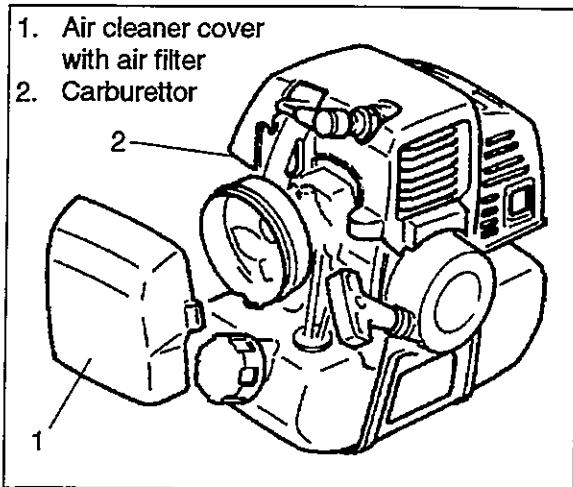

CLEANING AIR FILTER

- Close choke and remove air cleaner cover.
- Remove air filter (air filter is located inside air cleaner cover).
- Brush dirt from filter or clean with compressed air.
- Reinstall filter and cover.

NOTE

If filter is excessive dirty or no longer fits properly, replace it.

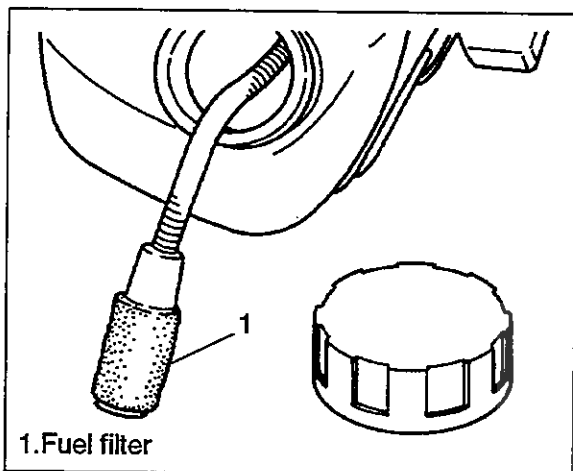

REPLACING FUEL FILTER

- Use a piece of steel wire or the like to pick up fuel filter through fuel tank opening.
- Pull old filter from fuel line.
- Install new fuel filter.

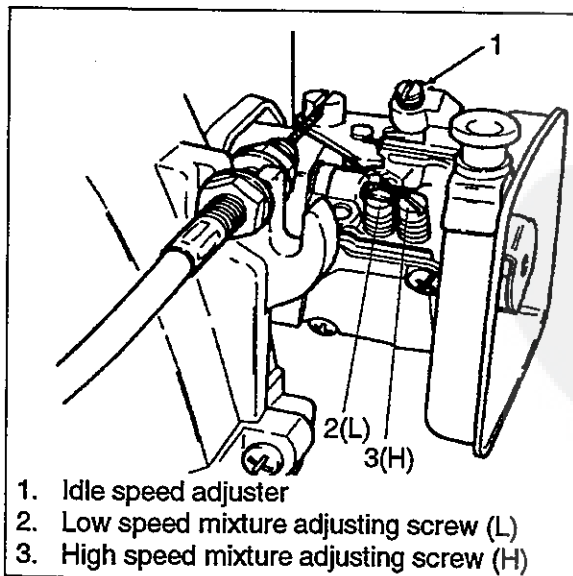

CARBURETTOR ADJUSTMENT

Every unit is test run at the factory and the carburettor is fine tuned for maximum performance. Any change from this setting should be performed only with the aid of an accurate tachometer (see Specification for rpm setting). If carburettor adjustment is performed without a tachometer, only the Basic Setting adjustment is recommended.

Before adjusting carburettor, clean or replace air filter, start engine and run several minutes to bring it to operating temperature.

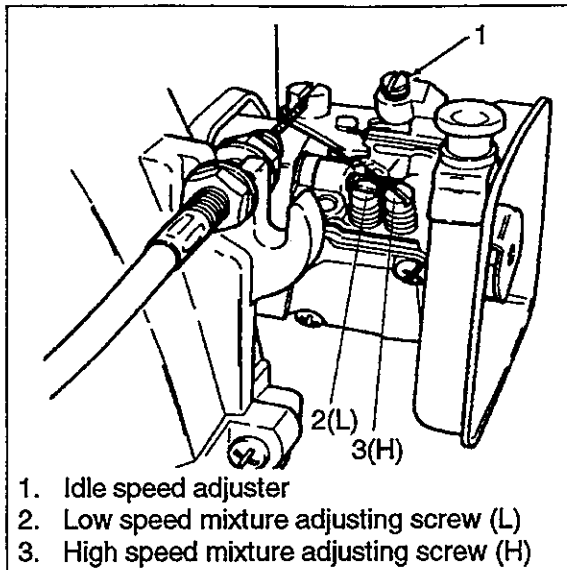

IDLE SPEED ADJUSTMENT

Turn idle speed adjuster clockwise until cutting attachment begins to turn, then turn screw out counterclockwise until cutting attachment stops turning. Turn screw out, counterclockwise, and additional 1/4 turn.

CAUTION

Cutting attachment must not turn when unit is idling.

BASIC SETTING

1. Stop engine and turn both low (L) and high (H) speed mixture adjusters in, clockwise until they stop and are lightly seated.

CAUTION

DO NOT over tighten (L) / (H) adjusters. Forcing them to tighten will damage the carburettor.

2. Turn low speed mixture adjuster (L) out, counterclockwise 1-1/2 turn. Turn high speed mixture adjuster (H) out counterclockwise 1-1/2 turn.

FINE TUNING

(Requires Accurate Tachometer)

1. Start engine and allow to run at high idle until warm.
2. Adjust idle speed if necessary (2,500 ~ 3,000 rpm).
3. Always begin fine tuning with low speed mixture adjuster (L).

4. Slowly turn (L) adjuster clockwise, try to reach maximum idle speed.
5. Turn (L) adjuster counterclockwise 1/8 ~ 1/4 turn.
6. Turn idle speed adjuster clockwise until cutting attachment begins to turn.
7. Turn idle speed adjuster counterclockwise 1/2 turn or until cutting attachment stops.

HIGH SPEED ADJUSTMENT

CAUTION

Improper high speed mixture adjustment can result in lean operation and consequent severe engine damage.

1. While engine running at full throttle, turn (H) adjuster slowly clockwise until engine runs smoothly under no load.

CAUTION

Do not run engine on full throttle longer than 5 ~ 6 seconds during high speed mixture adjuster (H) adjustment to avoid damage to engine.

2. Turn (H) adjuster counterclockwise 1/8 turn to obtain optimum fuel for full power under the load conditions.
3. After the high speed adjustment has been completed, and should the engine hesitate during acceleration from idle to full throttle, turn (H) adjuster counterclockwise until smooth acceleration is obtained. Make sure that the final engine speed does not exceed 11,500 rpm.

CAUTION

The engine will overheat when the high speed mixture adjuster (H) is adjusted to the lean condition reducing engine life.

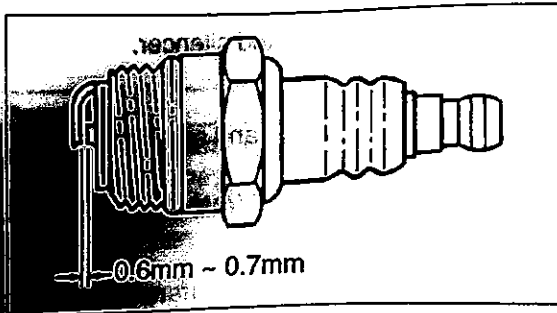

CHECK SPARK PLUG

- Check plug gap. Correct gap is 0.6 ~ 0.7 mm (0.024 ~ 0.028 in).
- Inspect electrode for wear.
- Inspect insulator for oil or other deposits.
- Replace plug if needed and tighten to 145 ~155 kgfcm (125 ~ 135 in.lb).

COOLING SYSTEM MAINTENANCE

CAUTION

To maintain proper engine operating temperature, cooling air must pass freely through the cylinder fin area. This flow of air carries combustion heat away from the engine.

Overheating and engine seizure can occur when:

- Air intakes are blocked, preventing cooling air from reaching the cylinder, or
- Dust and grass build up on the outside of the cylinder. This build-up insulates the engine and prevents the heat from leaving.

Removal of cooling passage blockages or cleaning of cylinder fins is considered "Normal Maintenance". Any resultant failure attributed to lack of maintenance is not warranted.

- Remove dust and dirt from between fins.

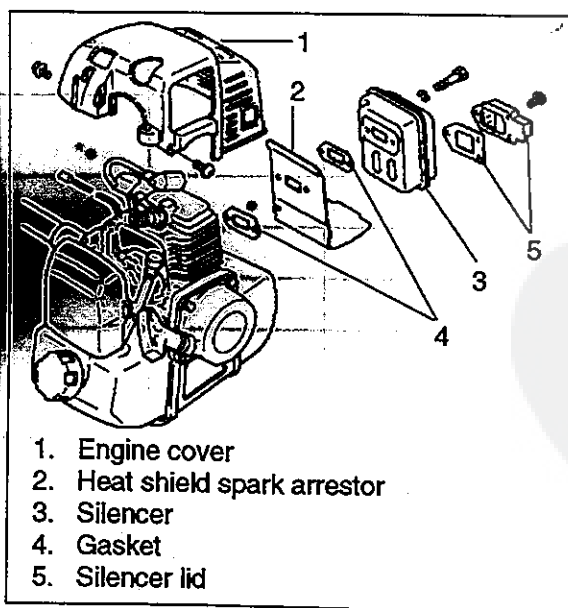
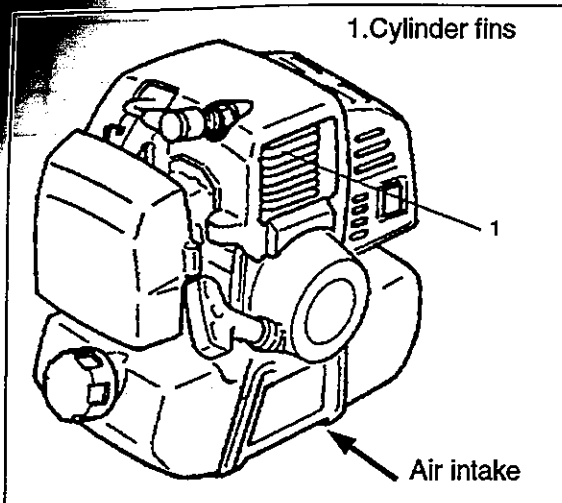

CLEANING SILENCER AND EXHAUST PORT

- Remove spark plug lead from spark plug, and throttle cable from carburettor swivel.
- Remove the four screws which secure engine cover.
- Remove engine cover.
- Remove silencer and heat shield.
- Place piston at top dead centre. Clean deposits from silencer and cylinder exhaust port.

NOTE

Be careful not to scratch the cylinder or piston when cleaning the cylinder exhaust port.

- Inspect gasket, replace if damaged.

- Install heat shield and silencer.
- Install silencer lid.
- Install engine cover and spark plug lead.

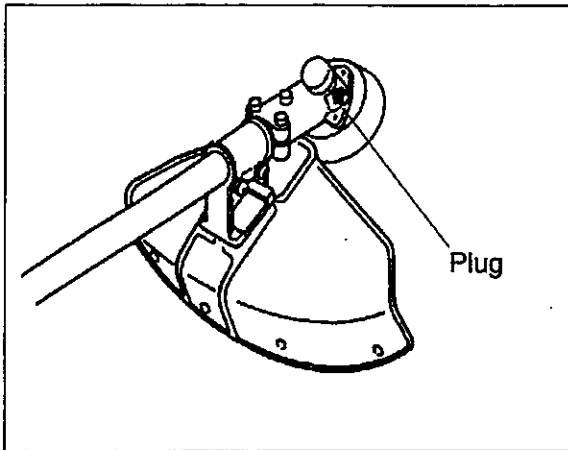

ANGLE TRANSMISSION AND SHAFT TUBE

- Remove plug from angle transmission.
- Add grease, if necessary, using low pressure pump.

NOTE

Use good quality lithium multi grease.
DO NOT overfill housing.

- Reinstall plug.

SERVICING GUIDE

AREA	MAINTENANCE	PAGE	BEFORE USE	MONTHLY	YEARLY
Air Filter	Clean/Replace	21	•		
Fuel Filter	Inspect/Replace	21	•		
Spark Plug	Inspect/Clean	23		•	
Carburettor	Adjust/Replace	21		•	
Cylinder Fins	Inspect/Clean	23			•
Silencer	Inspect/Clean	23	•		
Shaft Tube	Grease	24		•	
Angle Transmission	Grease	24			•*
Starter Rope	Inspect/Replace	-		•	
Cut-off Knife	Inspect/Clean	-	•		
Fuel System	Inspect/Repair	-	•		
Screw, Bolts & Nuts	Inspect, Tighten/Replace	-	•		

IMPORTANT

Time intervals are maximum. Actual use and your experience will determine the frequency of required maintenance.

* Or 50 hours, whichever occurs first.

TROUBLESHOOTING

Trouble		Cause	Remedy
Engine	starts hard does not start		
Engine cranks	Fuel at carburettor → No fuel at carburettor	<ul style="list-style-type: none"> • Fuel strainer clogged • Fuel line clogged • Carburettor 	<ul style="list-style-type: none"> • Clean • Clean • See your Echo dealer
	Fuel at cylinder → No fuel at cylinder	<ul style="list-style-type: none"> • Carburettor 	<ul style="list-style-type: none"> • See your Echo dealer
	→ Silencer wet with fuel	<ul style="list-style-type: none"> • Fuel mixture is too rich 	<ul style="list-style-type: none"> • Open choke • Clean/replace air filter • Adjust carburettor • See your Echo dealer
	Spark at end of plug wire → No spark at end of plug wire	<ul style="list-style-type: none"> • Ignition switch off • Electrical problem 	<ul style="list-style-type: none"> • Turn switch on • See your Echo dealer
	Spark at plug → No spark at plug	<ul style="list-style-type: none"> • Spark gap incorrect • Covered with carbon • Fouled with fuel • Spark plug defective 	<ul style="list-style-type: none"> • Adjust 0.6 ~ 0.7 mm (0.024 ~ 0.028 in) • Clean or replace • Clean or replace • Replace plug
Engine does not crank		<ul style="list-style-type: none"> • Internal engine problem 	<ul style="list-style-type: none"> • See your Echo dealer
Engine runs	Dies or accelerates poorly	<ul style="list-style-type: none"> • Air filter dirty • Fuel filter dirty • Fuel vent plugged • Spark plug • Carburettor • Cooling system plugged • Exhaust port/silencer lid plugged 	<ul style="list-style-type: none"> • Clean or replace • Replace • Clean • Clean and adjust/replace • Adjust • Clean • Clean

WARNING  **DANGER**
 ALL TRIMMER SERVICING, OTHER THAN THE ITEMS LISTED IN THE OPERATOR'S MANUAL SHOULD BE PERFORMED BY COMPETENT TRIMMER SERVICE PERSONNEL.

STORAGE

LONG TERM STORAGE (Over 60 Days)

Do not store your unit for a prolonged period of time (60 days or longer) without performing protective storage maintenance which includes the following:

1. Store unit in a dry, dust free place, out of the reach of children.

WARNING  **DANGER**
DO NOT STORE IN ENCLOSURE WHERE
FUEL FUMES MAY ACCUMULATE OR
REACH AN OPEN FLAME OR SPARK.

2. Place ignition switch in STOP position.
3. Remove accumulation of grease, oil, dirt and debris from exterior of unit.
4. Perform all periodic lubrication and services that are required.
5. Tighten all the screws and nuts.

6. Drain the fuel tank completely and pull the starter handle several times to remove fuel from the carburetter.
7. Remove the spark plug and pour 1/2 tablespoon of fresh, clean, two-stroke engine oil into the cylinder through the spark plug hole.
 - A. Place a clean cloth over the spark plug hole.
 - B. Pull the recoil starter handle 2 ~ 3 times to distribute the oil inside the engine.
 - C. Observe the piston location through the spark plug hole. Pull the recoil handle slowly until the piston reaches the top of its travel and leave it there.
8. Install the spark plug (do not connect ignition cable).

NOTE











For future reference, you should keep this operator's manual.



SPECIFICATIONS

		SRM-2010 (L)
Masses		
unit without cutting attachment, empty tank	kg	4.7
unit with specified cutting attachment, empty tank	kg	5.0
unit with specified cutting attachment, full tank	kg	5.3
Volume		
fuel tank	ℓ	0.4
Cutting attachment		
nylon line head		SRAH - 200
line diameter	mm	2.4
line length	m	2.5 x 2 lines
thread		Left-handed M10 x 1.25
Option		
nylon line disc		MH-2
line diameter	mm	2.4
Gear ratio		
gear ratio and lubrication		1 : 1.36 reduction and shell deipena or good quality lithium grease
Rotational direction of output shaft seen from above		Counter-clockwise
External dimensions		
length x width x height	mm	1,745 x 215 x 351
Engine		
type		Air cooled two stroke single cylinder
engine displacement	cm ³	21.2
maximum shaft brake power, measured in accordance with ISO 8893	kW	0.6
engine speed at maximum engine power	min ⁻¹	6,500
recommended maximum engine speed	min ⁻¹	9,000
output shaft speed	min ⁻¹	2,800
recommended engine idling speed	min ⁻¹	3,600
engine speed at beginning of clutch engagement	min ⁻¹	Diaphragm type
carburettor		Flywheel magneto - CDI system
Ignition	rpm	CHAMPION RCJ-7Y
spark plug		Recoil starter
starter		Automatic centrifugal clutch
clutch		
Fuel consumption		
mixing ratio		Regular grade petrol 25 parts : 1 part (4%) an air cooled two stroke engine oil of a reputable brand name
fuel consumption at maximum engine power	ℓ/h	0.541
specified fuel consumption at maximum engine power	g/kWh	690
Sound pressure level		
L_{PA2v}	dB(A)	94.9
Sound power level		
L_{WA2v}	dB(A)	103
Vibration levels		
idling	m/s ²	9.1
racing	m/s ²	13.2

DECALS AND SYMBOLS

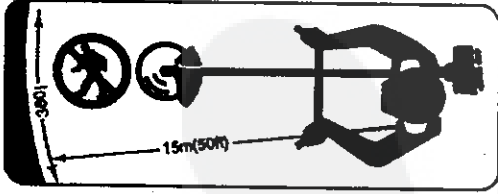
Symbol form/shape	Symbol description/application	Symbol form/shape	Symbol description/application
	Carefully read the operator's manual		Fuel and oil mixture
	Wear eyes, ears and head protection		Safety alert
	Emergency stop	L	Carburettor adjustment - Low speed mixture
	Warning! Thrown objects!	H	Carburettor adjustment - High speed mixture
	Usage without guard not permitted	T	Carburettor adjustment - Idle speed
	Usage of metal blades not permitted		The maximum speed of the cutting attachment shaft in rev/min
	Warning, side thrust		Circle and slash symbol means whatever is shown is prohibited
	Keep bystanders away 15 meters (50 feet)		

DECLARATION "CE" OF CONFORMITY

The undersigned manufacturer:

KIORITZ CORPORATION
7-2 SUEHIROCHO 1-CHOME
OHME ; TOKYO 198
JAPAN

declares that the hereunder specified new unit:

GRASS-TRIMMER

Brand : **ECHO**
Type : **SRM-2010**

complies with:

- * the requirements of Directive 89/392/EEC
(use of harmonized standard pr EN 31806).
- * the requirements of Directive 89/336/EEC
(use of harmonized standards EN 50081-1, EN 50082-1, EN 55014 & EN 55022).

Tokyo,
September, 1st 1995

KIORITZ CORPORATION

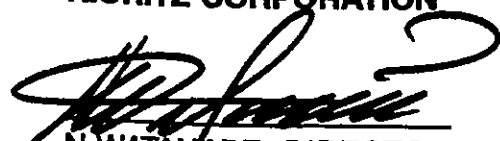
N. WATANABE, DIRECTOR

(GB)



KIORITZ CORPORATION

7-2 SUEHIROCHO 1-CHOME, OHME, TOKYO 198, JAPAN
PHONE: 81-428-32-6118. FAX: 81-428-32-6145.
TELEX: 2852070 KIORIT J



ECHO.

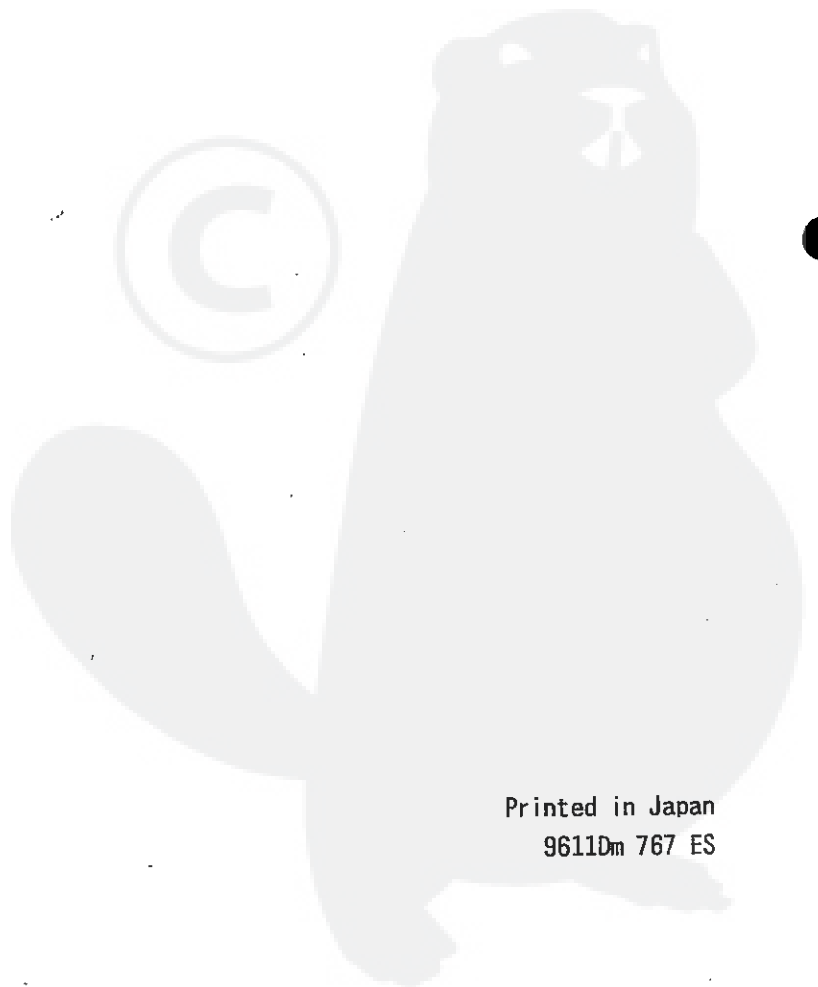

898615-46733
X753227-2303

Printed in Japan
9611Dm 767 ES