

OPERATOR'S MANUAL

ECHO TRIMMER/ BRUSHCUTTER SRM-200AE

CAUTION

Read Rules for Safe Operation
and Instructions Carefully



898 571-2033 2



**IMPORTANT
RULES FOR SAFE OPERATION**

1. Obey Rules and/or Regulations in your area.
2. Read this Operator's Manual well to acquaint yourself with how to handle the unit safely and effectively before use.
 - Before starting operation, study the working procedures well.
 - If there are any questions, contact and inquire with your distributor or dealer.
3. Never operate the unit when you are fatigued.
 - Fatigue causes carelessness.
 - Keep sufficient rest periods and breaks when operating the unit.
 - Be more cautious before rest periods and before the end of your shift.
4. Handle gasoline with care. It is highly inflammable.
 - Always store gasoline in an approved container.
 - Handle at a clean and cleared place and away from fire.
 - Do not smoke while handling fuel.
 - Always stop the engine to refuel the tank.
 - Do not refuel a hot engine. Wait until the engine has cooled down.
 - Avoid spilling fuel or oil. Spilled fuel should always be wiped up.
 - Move at least three meters (10 feet) away from the fueling point before starting engine.
 - Do not remove the fuel tank cap when engine is still warm or running.
5. When transporting, checking or adjusting the unit be sure the engine is stopped.
6. Do not operate in unventilated areas. Exhaust gas is highly poisonous.
7. Do not operate without shield in correct position.
8. Before starting up the engine, make sure that the cutter head is not touching anything.
9. Always wear safety footwear, safety goggles and ear protectors where possible.
10. Do not allow either people or animals into the work area.
 - When two or more operators are working together, a safe distance should be kept between them.
11. Do not smoke when operating.
12. Be sure of your footing when operating.
13. Always hold the unit firmly with both hands with the thumb and fingers encircling the handles.
14. To avoid hitting small stones or other debris, do not cut too close to the ground.
15. Before setting down the trimmer, switch off the engine.
16. When using a metal blade (Optional supply).
 - Use only the cutter blade designated by the manufacturer for this model. Make sure that the cutter is correctly fixed according to the instructions. Blade has to be well leveled and sharpened, teeth bottom must be well rounded.
 - Levelling should not be adjusted while engine is in motion. When crack is noticed on the cutter blade, never use it, but replace with a new one.

HANDLING OF NYLON CORD CUTTER HEAD

Install the nylon cord cutter head as follows.

1. Insert locking bar as shown.
2. Tighten head counter-clockwise.

ASSEMBLING

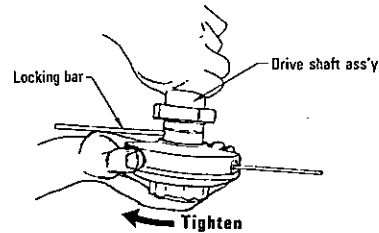

ADJUSTMENT OF NYLON CORD

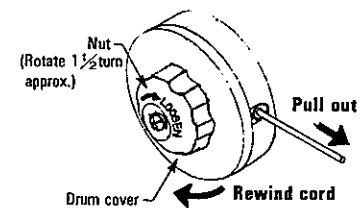

1. Loosen nut 1-1/2 turn approximately clockwise.
2. Pull out nylon cord to a specified length. (Approx. 5 in. : 13 cm)
3. Turn reel drum cover clockwise to rewind nylon cord when necessary.
4. After adjusting the length, tighten nut securely.

*When tip of cord worn out, cracked or shortened, cut the tip and adjust exposed cord length properly as above.

INSTALLING OF NEW NYLON CORD

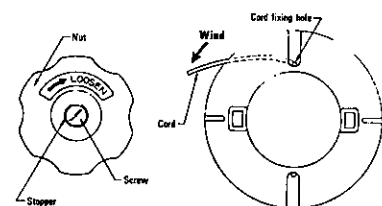

1. Remove screw and stopper. (standard thread)
2. Remove nut (left hand thread)
3. Take out cord reel and wind nylon cord as shown. Insert cord end into cord fixing hole and start the windings.
4. Assemble the parts backward of above steps 1 to 3.

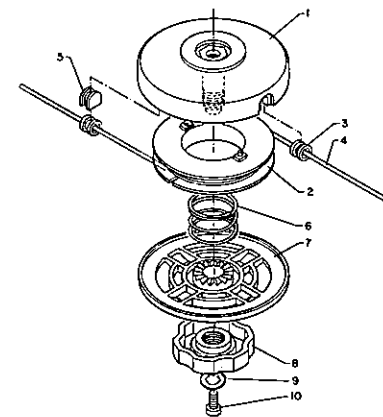

Key No.	Part Name
1.	Drum, cord reel
2.	Cord reel
3.	Cord guide
4.	Nylon cord
5.	Plug cord guide
6.	Spring
7.	Drum cover
8.	Nut
9.	Stopper
10.	Screw

CONTENTS

	Page
Rules for Safe Operation	2
Technical Data	3
Nomenclature of Parts	4
Assembling	4
Operation	5
Maintenance and Care	7
Trouble Shooting	9
Storage After Use	10
Parts Catalogue	11

TECHNICAL DATA

Dimension	L x W x H	cm (in.)	169 x 19 x 21.5 (66.5 x 7.6 x 8.2)
Weight		kg (lbs)	5.0 (11.0): w/o shoulder harness and cutter head
Engine	Type Displacement Max revolution Carburetor Ignition Spark plug Starter Clutch	cc (cu.in.) rpm	Air cooled two stroke single cylinder 21.2 (1.29) 8,000 Walbro diaphragm type WA Flywheel magneto: CDI (Capacitor Discharge Ignition) system NGK-BM6A or CHAMPION CJ-8 Recoil starter Automatic centrifugal clutch
Fuel	Mixing ratio Tank capacity	 litre (FL.OZ.US)	 Regular grade gasoline 25 parts: ECHO brand motor oil (or an air cooled two stroke engine oil of a reputable brand name) 1 part (4%) 0.5 (16.9)
Drive shaft ass'y	Cutter Cutter (option) Cutter (option) Gear housing Lubrication Drive shaft Shield		Nylon cord cutter head Eight (8) cutter blade, 8 in. Circular saw, 8 in. 60 degree spur bevel gears, ratio 1:1.25 (Counter-clockwise) Shell Delpena or good quality lithium grease High tensile solid steel, 5 bearings Plastic plate mounted on the gear housing

Technical data subject to change without notice.

(Note) U-shaped handle kit is available as optional supply. (Part No. 351 304-2033 0)

NOMENCLATURE OF PARTS

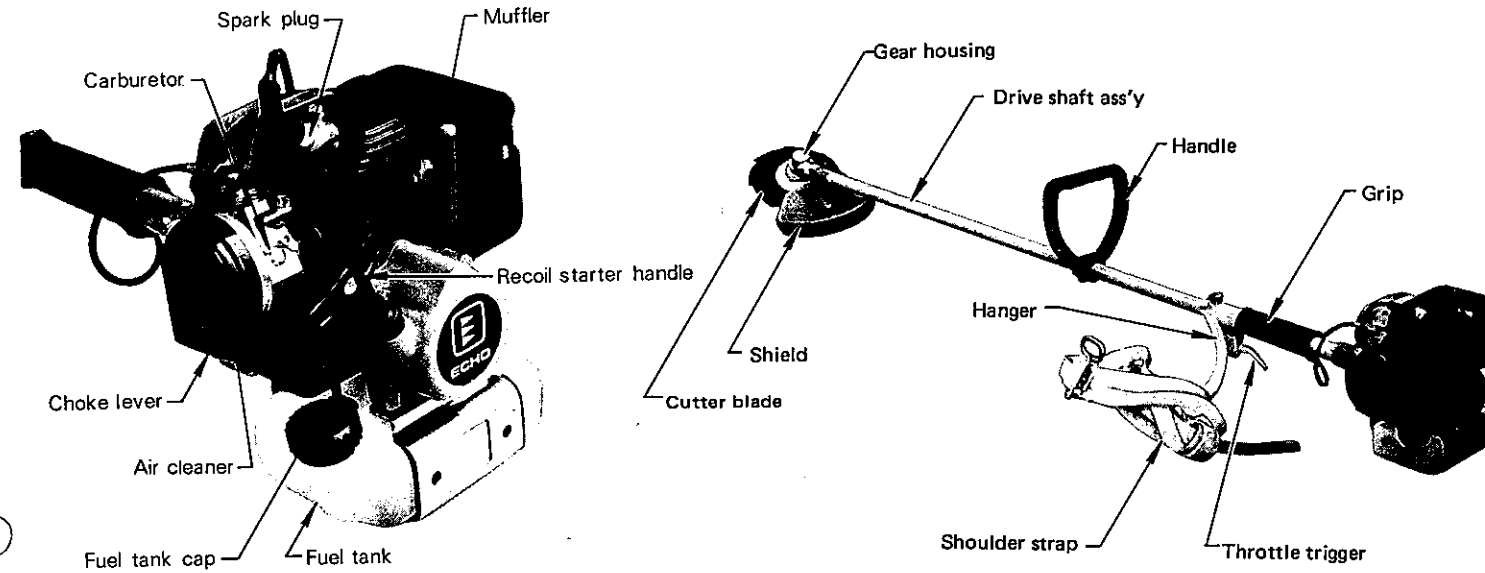

ASSEMBLING

DRIVE SHAFT

- Stand engine upright on a level floor.
- Loosen bolt at drive shaft end of the engine.
- Fit drive shaft assembly ensuring that the drive shaft is correctly engaged.
- The line on drive shaft housing must be in contact with the engine.
- Rotate drive shaft housing until gear housing is in line with the engine.
- Tighten bolt to fasten drive shaft ass'y.

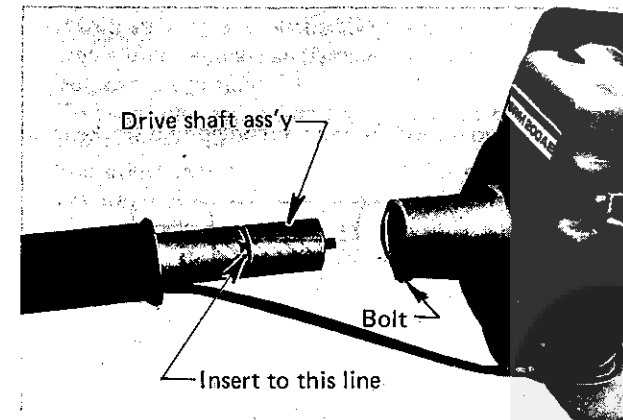

THROTTLE CABLE

As the engine is delivered with throttle cable (engine side) separated, assemble the cable to carburetor as follows.

- Remove nut (A) from throttle cable.
- Insert throttle cable through the hole of crankcase as shown.
- Replace nut (A) finger tight, and attach the inner cable to swivel on throttle lever ensuring that the nipple fits into socket provided on one side of slot.
- Tighten nut (A) to secure in this position.
- Check that throttle operates freely and returns to idle position.
- Do not loosen nut (B) unnecessarily, as it is located properly at the factory.



HANGER FOR SHOULDER STRAP

- Install hanger for shoulder strap as shown.
 - Remove screw and set hanger with a spacer.
 - Tighten screw securely.

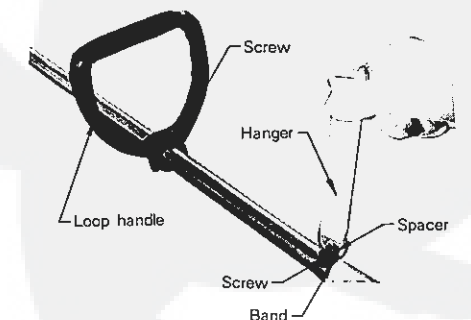

LOOP HANDLE

- Assemble loop handle and loop handle bracket to drive shaft ass'y loosely.
- Adjust location of handle to a convenient position. Tighten the bolts securely. (Refer to page 4)

SHIELD and PROTECTOR

Protector assembling (Protector for weed winding)

- Remove fixing plate.
- Align the arrow mark on the gear housing to hole of the protector. Tighten three screws.

Shield

- Fit the shield on the bracket and tighten four (4) screws.
- For safe operation, never use the trimmer without shield.

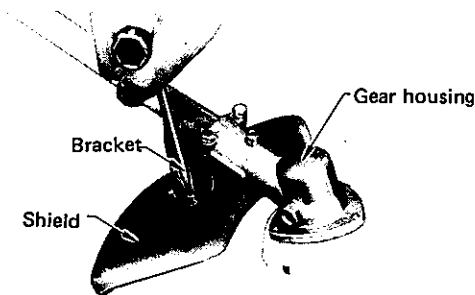
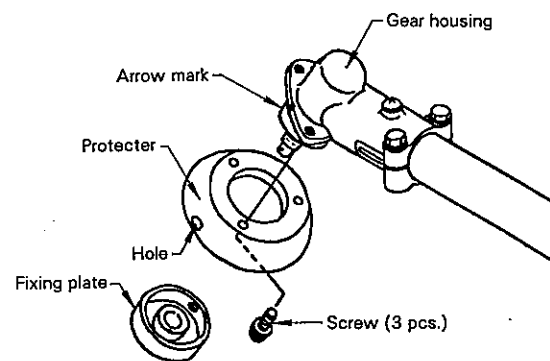

NYLON CORD HEAD

- As for the NYLON CORD CUTTER HEAD follow the instructions, page 1.

CUTTER BLADE (Optional supply at extra cost)

- After fixing the shield assemble the inner blade fixing plate, blade and outer blade fixing plate to the PTO shaft, then fit the nut finger tight.
- Lock the bearing housing inner blade fixing plate with locking rod and tighten the nut with box wrench. (Counterclockwise)

(NOTE) The nut is fitted with a left hand thread but must always be secured by a split pin.

Assemble cutter blade properly

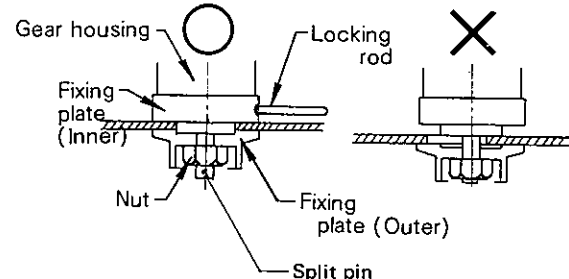

SHOULDER STRAP

- Fit shoulder strap to hanger, and readjust length of strap to maintain the cutter head parallel to the ground.

OPERATION

- Check for loose nuts, bolts and screws before using the unit every use.

FUEL

- Fuel used for this model is a mixture of regular grade gasoline and ECHO brand motor oil or an aircooled two stroke engine oil of a reputable brand name.

- Mixture ratio is Gasoline 25 parts: Oil 1 part. (4%)

- Fuel mixture at a rate other than 25 : 1 may cause malfunction of the engine. Watch out for mixture ratio.
- Pour 1/2 of the gasoline into a safe container, add oil and mix thoroughly.
- Now add the remainder of gasoline and mix again.
- Do not use motor oil other than that recommended above.
- Do not mix directly in engine fuel tank.

- After refueling, secure the fuel tank cap and wipe all spilled fuel with a dry cloth.

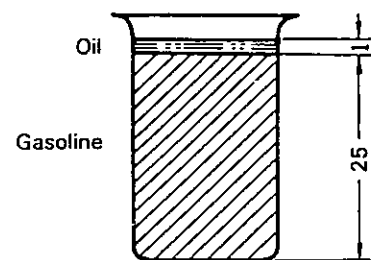

Fuel mix chart 25:1 (4%)

US		IMPERIAL		METRIC	
GAS	OIL	GAS	OIL	GAS	OIL
GAL.	FL. OZ.	GAL.	FL. OZ.	LITERS	C.C.
1	5.1	1	6.4	4	160
2	10.2	2	12.8	8	320
5	25.6	5	32.0	20	800

STARTING COLD ENGINE

- Turn switch to START/RUN position as shown. Turn choke lever to START (Close) position.
- Squeeze throttle trigger slightly and pull starter handle several times until first firing sound. Now, turn choke lever to RUN (Open) position, and if necessary, restart the engine again and allow to warm up for a few minutes before using.
- After idling, gradually open throttle and cutter blade will start to operate as the engine attains clutch engagement speed of 3000 ~ 3400 RPM approx.

(NOTE)

Recoil starter: Use short pulls — only 1/2—2/3 of starter rope for starting.

Always hold the unit firmly with both hands.

STARTING WARM ENGINE

- When engine is warm, start it by pulling recoil starter rope with switch positioned at START/RUN. (Keep choke lever in RUN (Open) position.)
- If engine does not start in a few tries, follow same procedures as to start cold engine.

STOPPING ENGINE

- Release throttle trigger and allow to run at an idle speed.
- Turn ignition switch to "STOP" position.

OPERATING THE TRIMMER

- Adjust handle to a convenient position for trimming as instructed on page 5.
- Allow the engine to warm up at a fast idle for a few minutes.
- Increase engine speed as necessary.
- When trimming weed or grass, swing the cutter head from right to left as you move forward.
 - Avoid striking any obstruction such as rocks, stones or tree stumps which can damage the cutter head. Do not cut into the ground.
 - To avoid damage to the engine, do not run the engine unloaded at full throttle.
- In the event that the cutter strikes an obstruction or is otherwise prevented from rotating in normal operation, the clutch will slip to prevent possible engine damage. In this case, stop the engine, free the cutter and then start the operation again.
- In an emergency, pull out pin of shoulder strap to detach the unit.

(CAUTION)

Do not allow either people or animals into the work area. Always wear safety goggles when cutting. Dress properly — Avoid loose clothing.

When grass or weeds have clogged the cutter head affecting normal operation, first, stop the engine and then remove it.

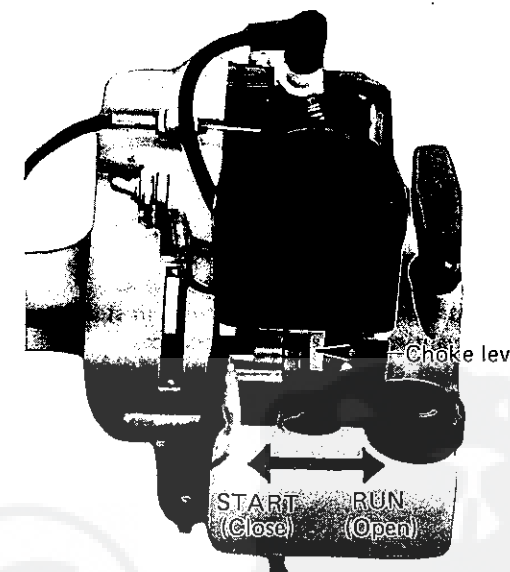
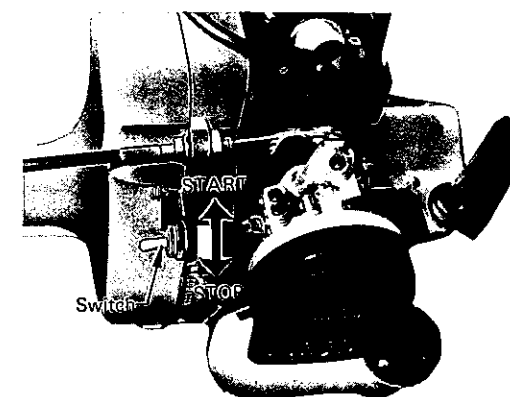

MAINTENANCE AND CARE

= ALWAYS KEEP THE UNIT CLEAN =

AIR FILTER

- Clean every day.
 - Remove air cleaner cover w/filter.
 - Brush off dust lightly or wash it in a non-inflammable solvent.
 - When you wash it in a solvent, dry it completely before putting back in place.

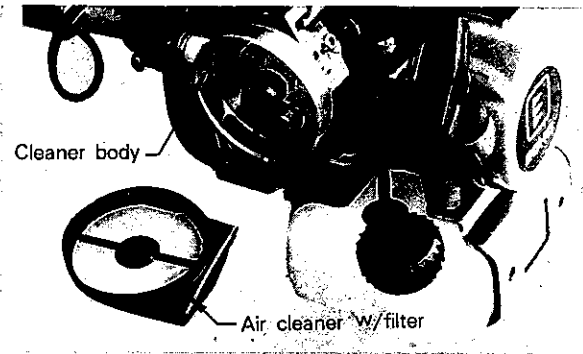

FUEL STRAINER

- Check periodically.
 - Do not allow dust to enter into fuel tank.
 - Clogged strainer will cause difficulty in starting engine or abnormalities in engine performances.
 - Pick up fuel strainer through fuel inlet port with a piece of steel wire or the like.
 - When strainer is dirty, wash it in a non-inflammable solvent.

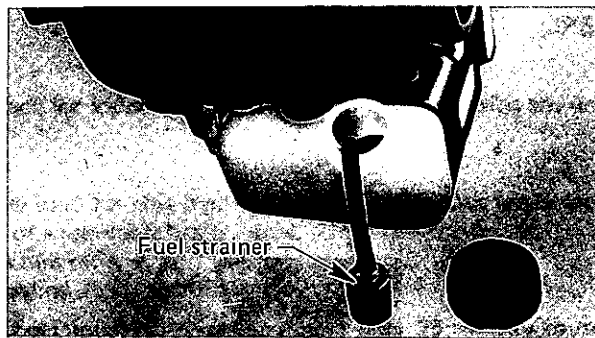

MUFFLER AND EXHAUST PORT

- Clean as necessary.
- Carbon deposit in cylinder exhaust port and muffler will reduce engine output.
 - Muffler can be removed by taking off muffler cover.
 - Be careful not to scratch cylinder or piston when cleaning cylinder exhaust port.

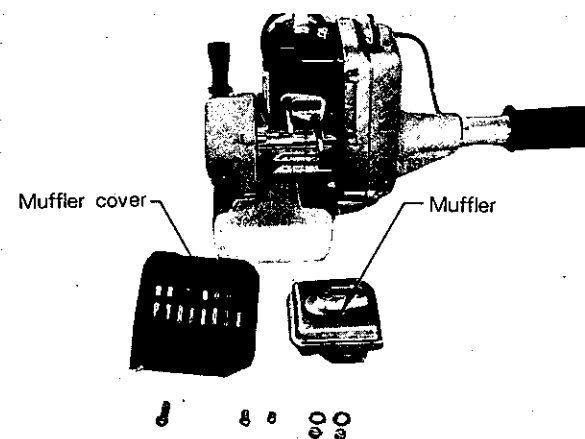

CYLINDER FINS

- Check periodically.
- Clogged fins will result in poor engine cooling.
- Remove dirt and dust from between fins to let cooling air pass easily.

SPARK PLUG

- Check periodically.
- Standard spark gap is 0.6–0.7 mm (0.024–0.028 in.).
- Replace if either electrode is worn or if the insulator is fouled by oil or other deposits.
- TORQUE = 145 – 155 kg-cm (125 – 135 in. lb)

CAUTION
Do not over torque.

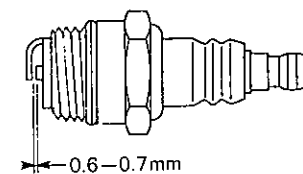

GEAR HOUSING

- Remove the bolt every 50 hours and check.
- Replenish as necessary, but do not overfill.
 - Shell delpena or good quality lithium multi grease is recommendable.

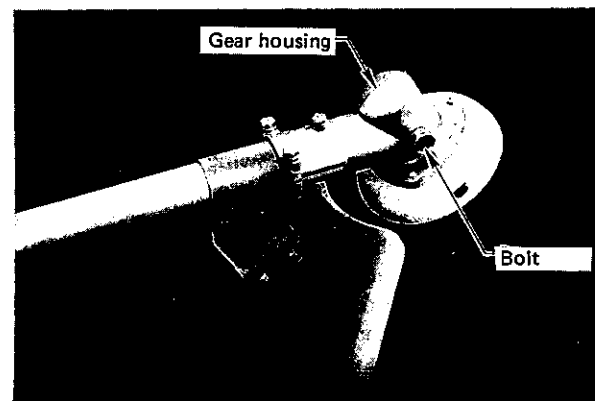

CARBURETOR

- Carburetor is set at the factory. So normally, further adjustment is unnecessary. If readjustment is required, refer to the following instructions.

CARBURETOR ADJUSTMENT

The diaphragm carburetor has three external adjustments, and to some extent, the adjustment of each will affect the other two. It will be necessary, therefore, to readjust each until satisfactory performance is achieved.

1. Idle speed adjusting screw.

This adjustment controls the throttle opening in the idle position.
 2. Low (LO) speed needle screw.

The low speed needle controls the volume of fuel/oil mixture at low engine speed. It also controls the supplementary fuel required to obtain smooth progression from idling to high speed.
 3. High (HI) speed needle screw.

The high speed needle controls the volume of fuel/oil mixture at full throttle opening.
- Turn both 'HI' and 'LO' needles clockwise until fully closed.

Do not use excessive force

Unscrew the 'LO' needle one complete turn.

Turn the idle speed adjustment screw clockwise until the throttle is slightly open.

Start the engine and run for a few minutes on high idle until the engine is warm. Allow the engine to idle, and if necessary, readjust the idle speed screw to keep the engine from stalling.

'LO' SPEED ADJUSTMENT

Turn the 'LO' needle clockwise slowly and note the position at which the engine speed is reduced. Now turn the 'LO' needle counterclockwise and again note the position when speed is reduced. Set the needle in the midway position. Finally, adjust the engine idling speed by turning the idle speed screw in a clockwise direction until the clutch just begins to engage. This indicates a speed of 3000–3400 RPM. Now reduce engine speed by turning the screw counterclockwise one half turn.

NYLON CORD CUTTER

- Refer to instructions, page 1.

EIGHT (8) CUTTER BLADE (Optional supply at extra cost)

- Use only the blade designated by the manufacturer for this model.
- When crack is noticed on the blade, never use it, but replace with a new one.
- Round the teeth bottom for 1 – 2 mm radius in order to avoid the crack using a round file.
 - Rounded part is not to be sharpened.
 - Sharpen each cutter equally so as to retain the balance of the blade.
 - In sharpening the edge by use of a grinder, do not cool the cutter abruptly by immersing it in water.

MAGNETO

The unit is incorporated with magneto of C.D.I. (Capacitor Discharge Ignition) system, which does not require adjustment of ignition timing and the contact breaker point gap. Ensure wire connections and couplers assembling.

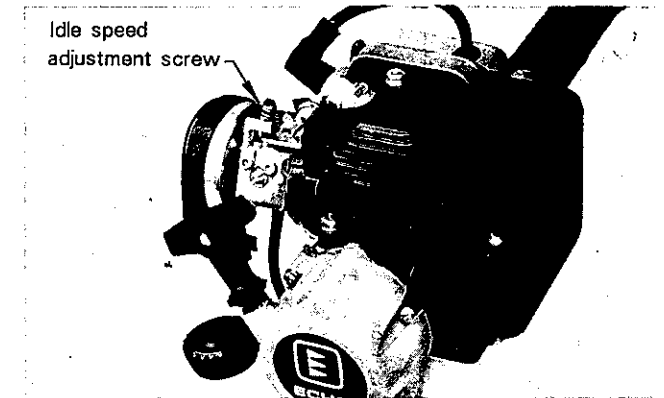
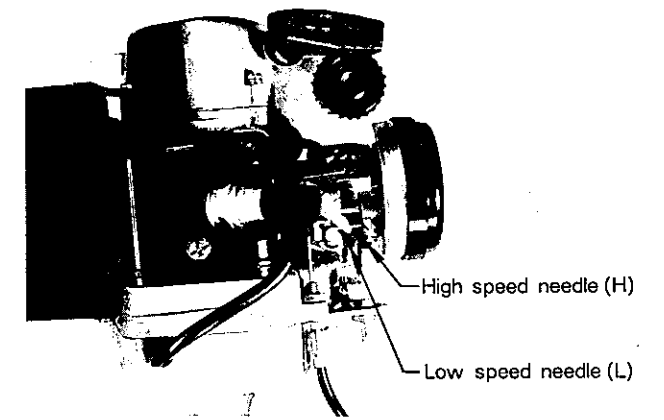

'HI' SPEED ADJUSTMENT

Engine must be at normal operating temperature. Turn the 'HI' needle counterclockwise 1-1/4 turns. Run the engine at full throttle and turn the 'HI' needle slowly clockwise until the engine runs smoothly without "four stroking" on no load. Turn the needle open again (counterclockwise) 1/8" turn to obtain optimum fuel for full power under load conditions.

CAUTION
DO NOT RUN THE ENGINE ON FULL THROTTLE LONGER THAN 5-6 SECONDS TO AVOID DAMAGE TO ENGINE.

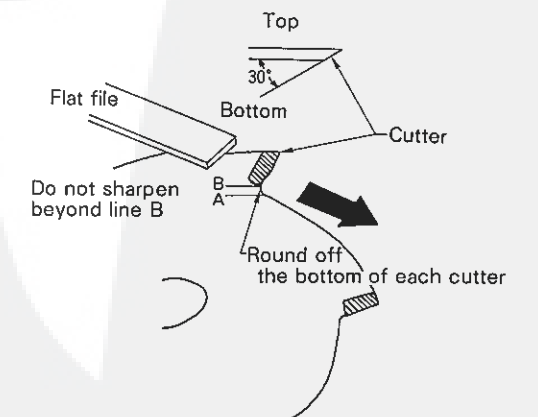

TROUBLE SHOOTING

Poor performance of the engine and/or trimming mechanism can normally be prevented by carefully following the above instructions.

Poor performances can easily be corrected even by a beginner.

When the engine does not function properly check the following three (3) points first.

- Is engine compression adequate?
- Is fuel system in good condition and is enough fuel being supplied?
- Is electrical system in good condition and is spark plug operating normally?

When there is serious trouble with the unit, do not try to repair it yourself but have your distributor or dealer do it for you. For detailed **TROUBLE SHOOTING** refer to tables 1 and 2. Locate the problem on the following charts and repair as necessary.

Table 1

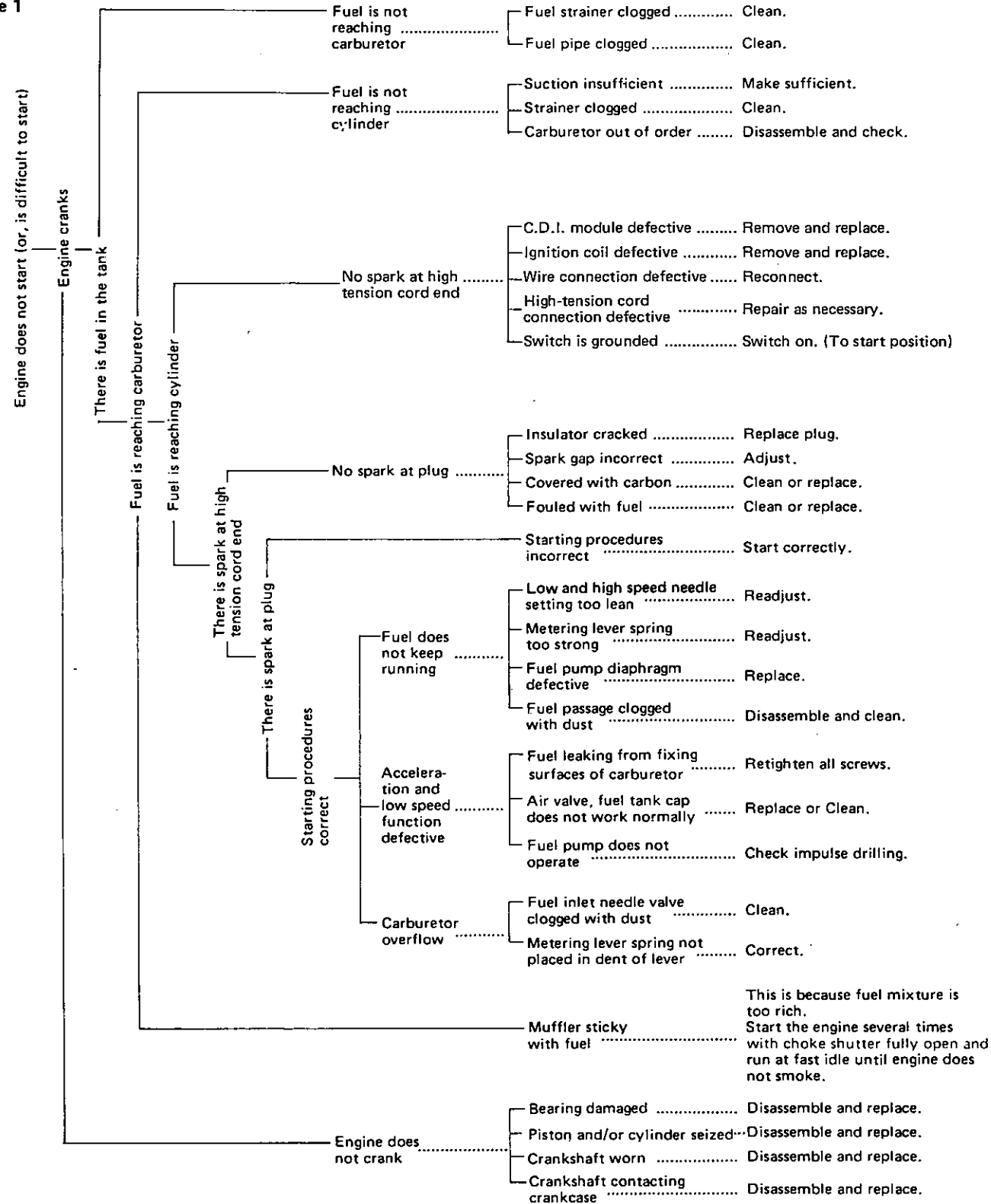
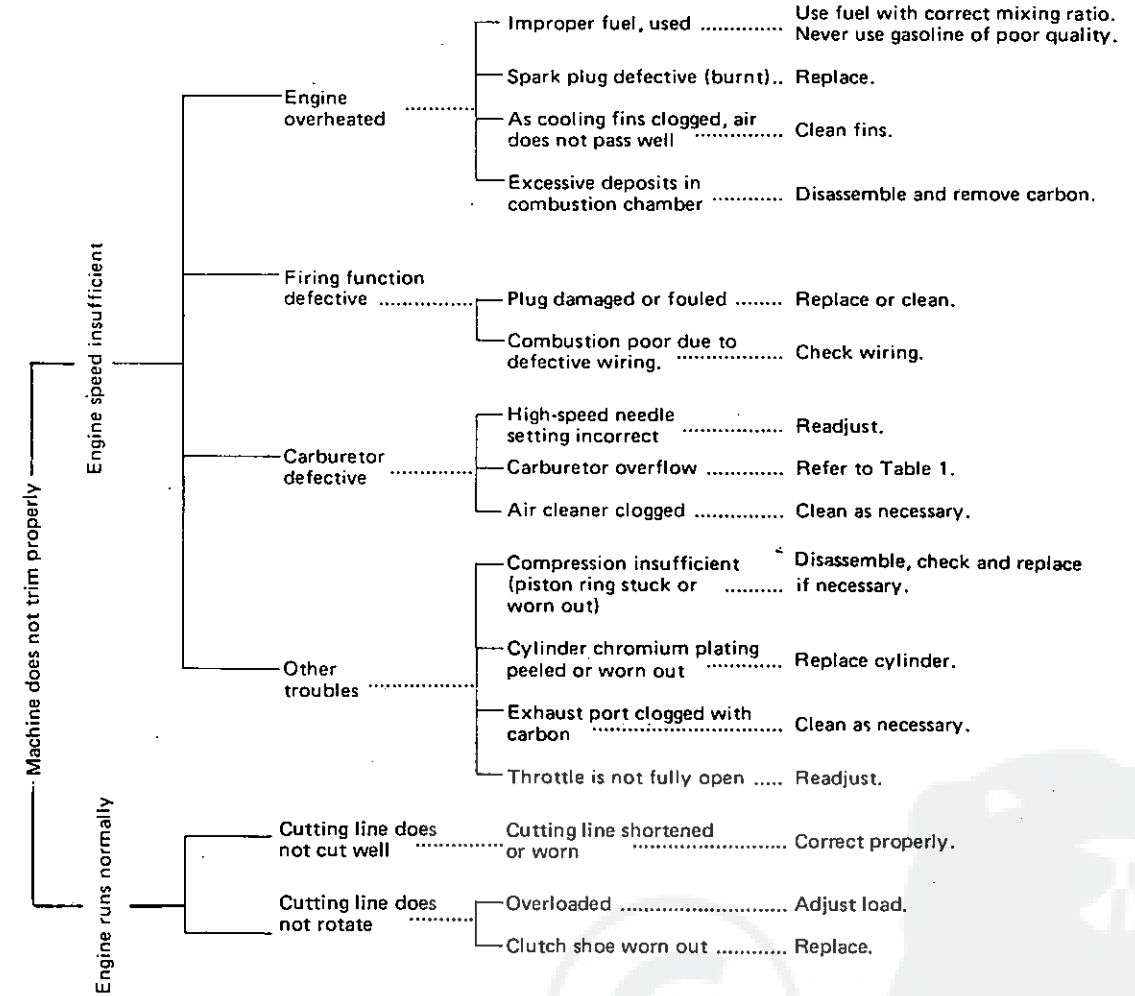

Table 2



STORAGE AFTER USE

- Inspect and adjust every part of the unit.
 - Completely clean every part, and repair, if necessary.
 - Apply thin coating of oil on metal parts to prevent rust.
 - Remove the cutter head, apply sufficient oil coating and wrap up in plastic.
- Drain fuel tank, pull starter handle slowly a few times to drain fuel from carburetor.
- Pour a small amount of clean motor oil into spark plug hole, pull starter handle and then crank the engine until **TOP DEAD CENTER**.
- Store in a dry area, free from dust.

PARTS CATALOGUE

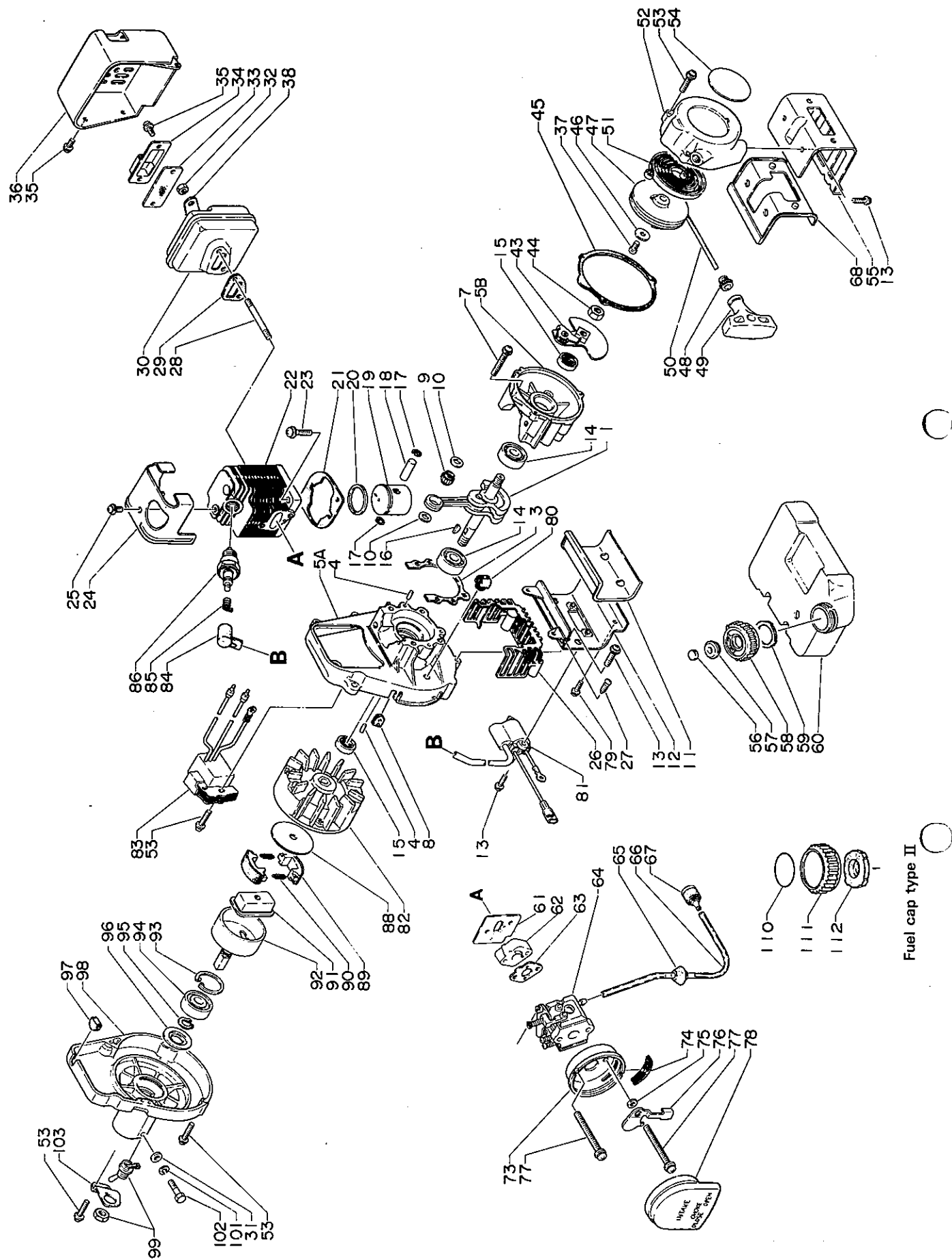

Key No.	Part No.	Q'ty	Description	Key No.	Part No.	Q'ty	Description
1- 1	100 100-0742 0	1	Crankshaft	1- 55	131 918-0732 0	1	Bracket, fuel tank
3	100 242-0492 0	1	Gasket, crankcase	***	131 004-0632 0	1	Cap ass'y, fuel tank
5	100 200-0742 0	1	Crankcase Set	56	-131 315-0502 0	1	Filter, check valve
4	-100 215-0393 0	4	Knock pin	57	-131 314-0632 0	1	Check valve
7	900 242-0503 0	4	Screw 5x30 w/W, SW	58	-131 017-0743 0	1	Cap, fuel tank
8	156 114-0231 0	1	Grommet	59	-131 016-0492 0	1	Gasket, fuel tank cap
9	100 113-0593 0	1	Needle bearing	60	131 010-0732 0	1	Fuel tank
10	100 014-0652 0	2	Spacer, piston pin	61	130 010-2163 0	1	Gasket
11	131 920-0732 0	1	Cushion	62	130 017-0652 0	1	Insulator
12	131 910-0742 0	1	Bracket, fuel tank	63	130 016-0492 1	1	Gasket
13	900 242-0401 4	4	Screw 4x14 w/W, SW	64	123 000-0652 0	1	Carburetor ass'y (WA-81)
14	900 810-3620 1	2	Ball bearing 6201	65	132 115-0492 0	1	Grommet
15	100 213-0553 0	2	Oil seal	66	132 010-0492 0	1	Fuel pipe
16	100 142-0031 0	1	Woodruff key	67	131 205-0732 0	1	Fuel strainer
17	100 015-0463 0	2	Circlip, piston pin	68	131 924-0732 0	1	Cushion
18	100 013-1021 0	1	Piston pin	73	130 301-0492 0	1	Case, air cleaner
19	100 010-0652 1	1	Piston	74	-178 810-0492 0	1	Grommet
20	100 011-0533 0	1	Piston ring	75	178 516-0083 0	1	Washer
21	101 010-0492 0	1	Gasket, cylinder base	76	178 515-0492 0	1	Choke shutter
22	101 011-0652 0	1	Cylinder	77	900 242-0505 7	2	Screw 5x57 w/W, SW
23	900 242-0602 0	2	Screw 6x20 w/W, SW	78	130 310-0492 2	1	Air filter
24	101 514-0652 0	1	Cylinder cover	79	900 242-0401 2	2	Screw 4x12
25	900 242-0501 0	1	Screw 5x10 w/W, SW	80	159 110-0742 0	1	Cord holder
26	100 616-0632 0	1	Dust filter	81	156 626-0742 0	1	Ignition coil
27	900 245-0401 4	2	Tapping screw 4x14	82	156 800-0742 0	1	Flywheel
28	101 014-0056 0	2	Stud bolt	83	156 601-0742 1	1	C.D. ignition module
*	145 803-0652 1	1	Muffler ass'y (S.A.M.)	84	159 012-0162 0	1	Cap, spark plug
29	-145 510-0903 0	1	Gasket, muffler	85	159 011-0051 0	1	Coil spring, plug cap
30	-145 806-0652 0	1	Muffler body	86	159 026-0393 0	1	Spark plug
33	-145 862-0652 0	1	Screen	88	175 019-0492 0	1	Side plate
34	-145 809-0652 0	1	Lid, muffler	89	175 009-0513 0	2	Clutch shoe
35	-900 242-0401 0	4	Screw 4x10 w/W, SW	90	175 018-0513 0	2	Clutch spring
36	-145 621-0652 0	1	Muffler cover	91	175 016-0492 0	1	Clutch boss
31	900 600-0000 5	1	Washer 5	92	175 010-0492 0	1	Clutch drum
32	433 020-0083 0	2	Lock nut 5	93	900 702-0003 2	1	Circlip 32
38	145 642-2333 0	1	Washer	94	900 819-3620 1	1	Ball bearing 6201
43	177 305-0492 0	1	Ratchet ass'y	95	900 701-0001 2	1	Circlip 12
44	900 502-0000 8	1	Nut 8	96	175 053-0492 0	1	Stopper
45	100 615-0492 0	1	Gasket, recoil	97	101 538-0742 0	1	Plug
**	177 200-0742 0	1	Recoil starter ass'y	98	101 511-0652 0	1	Fan cover
37	-900 241-0401 0	1	Screw 4x10 w/SW	99	163 400-0652 0	1	Stop switch
46	-177 214-2043 0	1	Washer	101	900 605-0000 5	1	Spring washer 5
47	-177 215-0492 0	1	Recoil drum	102	900 151-0502 5	1	Bolt 5x25
48	-177 226-0653 0	1	Starter rope	103	163 810-0652 0	1	Bracket, switch
49	-177 228-0653 0	1	Starter handle	Fuel cap TYPE II			
50	-177 227-0533 0	1	Rope guide	110	898 315-0393 0	1	Decal
51	-177 220-0653 0	1	Rewind spring	***	131 004-0493 2	1	Cap ass'y, fuel tank
52	-177 209-0742 0	1	Starter case	111	-131 017-0493 0	1	Cap, fuel tank
53	900 242-0402 0	9	Screw 4x20 w/W, SW	112	-131 314-0493 0	1	Check valve
54	890 112-0603 1	1	Decal, ECHO				

Remarks:

*: Consists of 29, 30 and 33 thru 36.

**: Consists of 37 and 46 thru 52.

***: Consists of 56 thru 59.

73: Includes 74.

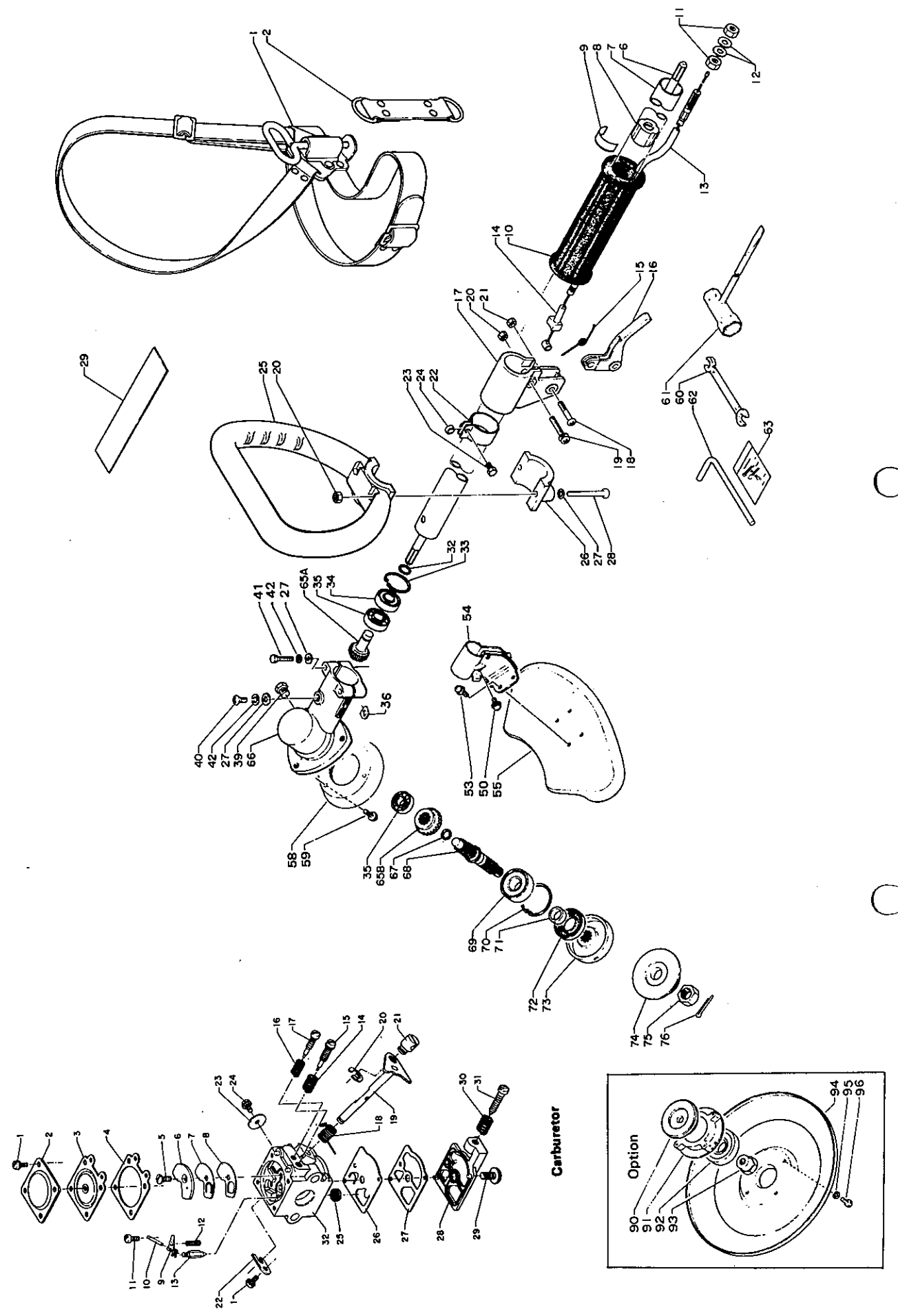

Key No.	Part No.	Q'ty	Description	Key No.	Part No.	Q'ty	Description
2- 1	301 000-0753 0	1	Shoulder strap	2- 34	-900 803-0060 9	1	Ball bearing 609
2	-301 305-0753 0	1	Strap	35	-900 800-0060 9	2	Ball bearing 609
6	610 011-0893 0	1	Shaft, drive	36	-610 239-0413 0	2	Spacer
7	610 206-0893 0	1	Housing ass'y	39	-900 100-0800 8	1	Bolt 8x8
8	-610 105-0893 0	4	Bush	40	-900 220-0401 0	1	Screw 4x10
9	890 152-0493 0	1	Decal	41	-900 100-0502 8	2	Bolt 5x28
10	351 012-0893 0	1	Grip	42	-900 605-0000 5	3	Spring washer 5
11	900 502-0000 6	2	Nut 6	58	-610 443-2123 2	1	Adapter
12	900 600-0000 6	2	Washer 6	59	-900 242-0502 0	3	Screw 5x20
13	178 001-0893 1	1	Throttle cable	65	-610 301-0893 0	1	Gear set
14	178 048-0563 0	1	Spacer	66	-610 460-0893 0	1	Gear housing
15	178 043-0693 0	1	Spring, return	67	-610 335-0713 0	1	Circlip
16	178 010-0563 0	1	Throttle trigger	68	-610 360-0893 1	1	Shaft, P.T.O.
17	178 024-0893 0	1	Bracket, trigger	69	-900 810-0620 1	1	Ball bearing 6201
18	178 110-0533 0	1	Screw	70	-900 702-0003 2	1	Circlip 32
19	900 242-0502 8	1	Screw 5x28	71	-610 315-0713 0	1	Spacer
20	900 500-0000 5	1	Nut 5	72	-610 413-0713 0	1	Oil seal
21	433 020-0083 0	1	Lock nut 5	73	-610 338-0893 0	1	Plate, blade fixing
22	301 207-0893 0	1	Hock	74	-610 314-0413 1	1	Plate, blade fixing
23	900 100-0501 8	1	Bolt 5x18	75	-900 511-0001 0	1	Nut 10 L-h
24	699 012-0333 0	1	Spacer	76	-900 300-2002 2	1	Split pin 2x22
25, 26	351 201-0893 0	1	handle set	60	895 112-0033 0	1	Spanner 8x10
20	-900 500-0000 5	2	Nut 5	61	895 410-0793 0	1	Wrench 17x19
27	-900 600-0000 5	2	Washer 5	62	897 518-0113 1	1	Locking tool
28	-900 220-0504 0	2	Screw 5x40	63	898 502-0113 0	1	10 pcs. split pin
29	890 160-0753 0	1	Decal, caution	90	610 314-0463 1	1	Fitting plate
*	699 000-2123 0	1	Shield ass'y	91	699 226-0543 0	1	Holder, bearing
50	-900 242-0501 4	2	Screw 5x14	92	900 814-0620 2	1	Ball bearing 6202
53	-900 242-0501 0	4	Screw 5x10	93	699 227-0463 0	1	Nut
54	-699 011-2123 0	1	Bracket, shield	94	699 228-0893 0	1	Cover plate
55	-699 010-2123 1	1	Shield	95	900 605-0000 5	4	Spring washer 5
**	610 402-2033 0	1	Gear housing ass'y	96	900 100-0501 2	4	Bolt 5x12
27	-900 600-0000 5	3	Washer 5	-	SRAH-200	1	Cord cutter head (Option)
32	-610 337-0893 0	1	Circlip				
33	-900 702-0002 5	1	Circlip 25				

Remarks:
 1: Includes 2.
 7: Includes 8.
 25, 26: Consists of 20, 27 and 28.
 *: Consists of 50, 53 thru 55.
 **: Consists of 27, 32 thru 35, 36 39 thru 42, 58, 59 and 67 thru 76.

Key No.	Part No.	Q'ty	Description	Key No.	Part No.	Q'ty	Description
3- *	123 000-0652 0	1	Carburetor ass'y (WA-81)	20	-123 127-1063 0	1	Clip
1	-123 144-0393 0	5	Screw	21	-123 172-0432 0	1	Swivel
2	-123 142-0393 0	1	Cover, metering diaphragm	22	-123 127-0393 0	1	Clip, throttle shaft
3	-123 141-0393 0	1	Diaphragm, metering	23	-123 116-0523 0	1	Valve, throttle
4	-123 140-0393 0	1	Gasket, m./diaphragm	24	-123 114-0393 0	1	Screw, throttle valve
5	-123 167-0523 0	1	Screw, circuit plate	25	-123 126-0393 0	1	Screen, inlet
6	-123 166-0393 0	1	Plate, circuit	26	-123 112-0393 0	1	Diaphragm, fuel pump
7	-123 165-0393 0	1	Diaphragm, circuit plate	27	-123 125-0393 0	1	Gasket, fuel pump
8	-123 164-0393 0	1	Gasket, circuit plate	28	-123 124-1113 0	1	Cover, fuel pump
9	-123 123-0393 0	1	Lever, metering	29	-123 110-0393 0	1	Screw, pump cover
10	-123 138-0393 0	1	Pin, metering lever	30	-123 133-1113 0	1	Spring, idle screw
11	-123 139-0393 0	1	Screw, metering lever pin	31	-123 134-0653 0	1	Screw, idle adjustment
12	-123 122-0393 0	1	Spring, metering lever	32	-Not Available	1	Body ass'y
13	-123 137-0393 0	1	Valve, inlet needle				
14	-123 119-0393 0	1	Spring, H.S. needle				
15	-123 120-0653 0	1	Needle, high speed				
16	-123 121-0393 0	1	Spring, idle needle				
17	-123 118-0652 0	1	Needle idle				
18	-123 113-0393 0	1	Spring, throttle return				
19	-123 117-0502 0	1	Shaft, throttle				

Remarks:
 3-*: Consists of 1 thru 32.



KIORITZ CORPORATION

5-1, SHIMORENJAKU 7-CHOME, MITAKA, TOKYO 181, JAPAN
PHONE:0422-48-6115 P.O. BOX 10 MITAKA TOKYO
CABLE ADDRESS:KIORITZ MITAKA TELEX:KIORITZ A J26592

ECHO

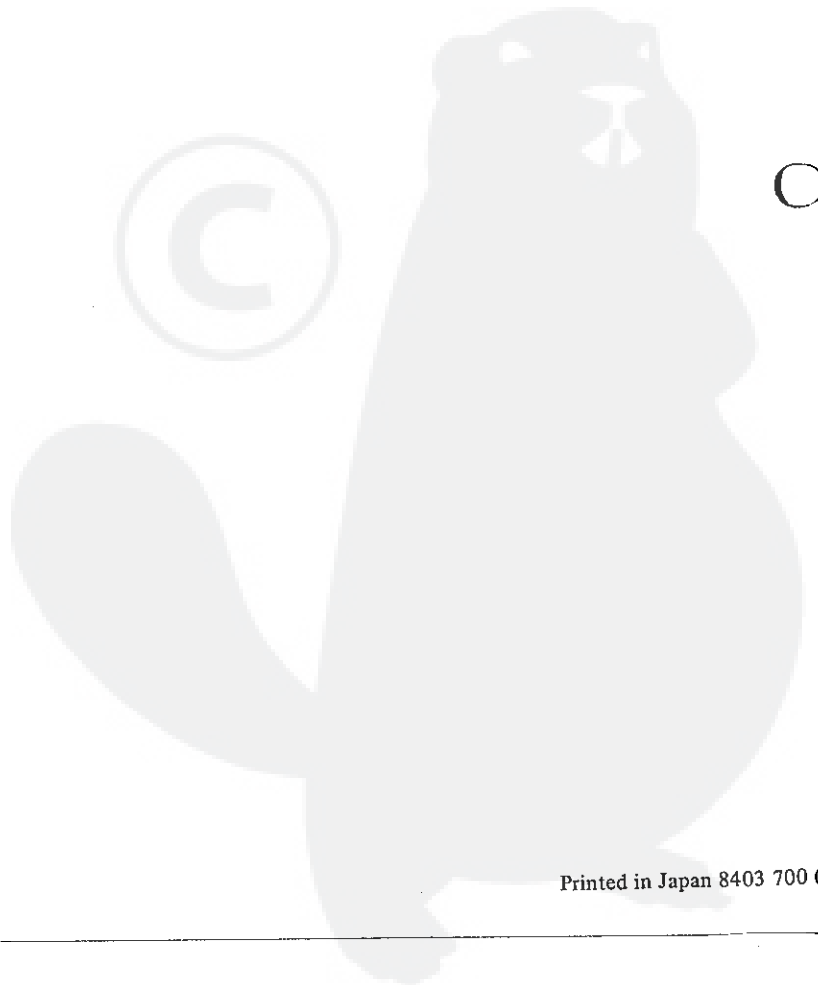

Printed in Japan 8403 700 (S)