

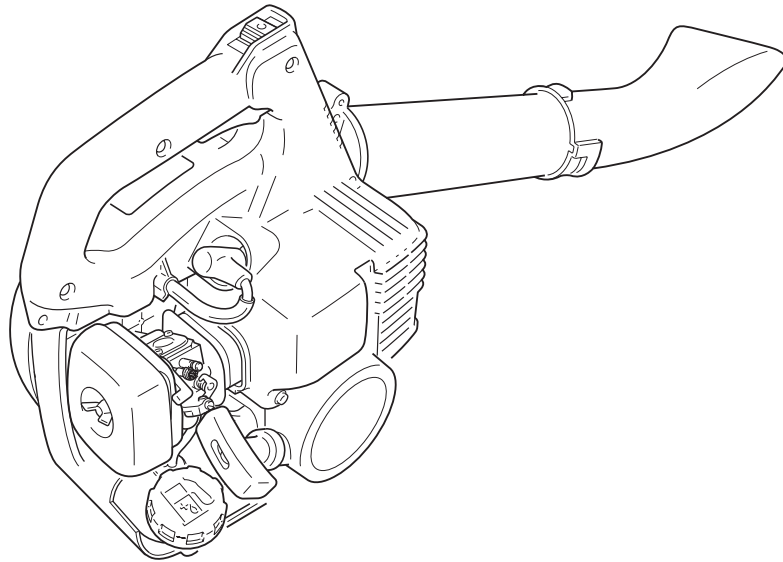

GB ENGLISH



OPERATOR'S MANUAL

PB-2350

⚠ WARNING

READ THE INSTRUCTIONS CAREFULLY AND FOLLOW THE RULES FOR SAFE OPERATION. FAILURE TO DO SO COULD RESULT IN SERIOUS INJURY.



Important information

Please ensure that you read the operator's manual before using your product.

○ Intended use of this product

- ♦ ECHO Power Blower are designed for vacuuming and processing a wide variety of fallen leaves and cut lawn. Also this unit is easily converted to a blower.
- ♦ Do not use this unit for any purpose other than aforementioned.

○ Users of the product

- ♦ You should not use this product until you have read the operator's manual carefully and fully absorbed its content.
- ♦ This product should not be used by anyone who has failed to read the operator's manual properly, is suffering from a cold, tiredness or otherwise in poor physical condition, or children.
- ♦ Keep in mind that the operator or user is responsible for accidents or hazards occurring to other people or their property.

○ About your operator's manual

- ♦ This manual contains necessary information about the assembly, operation, and maintenance of your product. Please read it carefully and absorb its contents.
- ♦ Always keep your manual in a place where it is readily accessible.
- ♦ If you have lost your manual or it is damaged and no longer readable, please purchase a new one from your ECHO DEALER.
- ♦ The units used in this manual are SI units (International System of Units). Figures in parentheses are reference values, and there may be a slight conversion error in some cases.

○ Loaning or assigning your product

- ♦ When loaning the product described in this manual to another party, ensure that the person borrowing and working with the product receives the operator's manual along with the product. If you assign your product to another party, please enclose the operator's manual with the product when handing it over.

○ Enquiries

- ♦ Please contact your ECHO DEALER for requests regarding information about your product, the purchase of consumables, repairs, and other such enquiries.

○ Notices

- ♦ The content of this manual may be changed without notice for the purpose of upgrades to the product. Some of the illustrations used may differ from the product itself in order to make the explanations clearer.
- ♦ This product requires the assembly of some parts.
- ♦ Please consult your ECHO DEALER if anything is unclear or of concern.

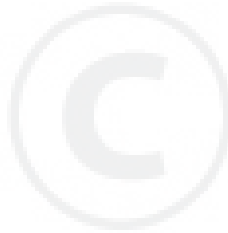

For safe use of your product.....	4
Warning notices	4
Other indicators	4
Symbols.....	4
Location in which the safety decal is attached.....	6
Handling fuel.....	7
Handling the engine.....	8
Handling the product	9
Packing list.....	12
Description	13
Before you start	14
Assembly	14
Preparing the fuel	16
Engine operation.....	17
Starting the engine	17
Stopping the engine.....	18
Operation	19
Operating vacuum	19
Operating blower	20
Maintenance and care	21
Servicing guidelines.....	21
Maintenance and care	21
Troubleshooting table	26
Long-term storage(30 days or more).....	27
Specifications.....	28
Declaration "CE" of conformity	29



For safe use of your product

Be careful to read this section before using your product.



○ The precautions described in this section contain important safety information. Please observe them carefully.

○ You must also read the precautions that appear in the body of the manual itself.

Text following a [diamond mark] mark describes the potential consequences of failing to observe the precaution.

Warning notices

Situations where there is a risk of physical injury to the operator and other people are indicated in this manual and on the product itself by the following warning notices. Always read and observe them carefully in order to ensure safe operation.

 DANGER	 WARNING	 CAUTION
This symbol accompanied by the word " DANGER " calls attentions to an act or a condition which will lead to serious personal injury or death of operators and bystanders.	This symbol accompanied by the word " WARNING " calls attentions to an act or a condition which can lead to serious personal injury or death of operators and bystanders.	" CAUTION " indicates a potentially hazardous situation which, if not avoided, may result in minor or moderate injury.







Other indicators

As well as warning notices, this manual uses the following explanatory symbols:











	Circle and slash symbol means whatever is shown is prohibited.	NOTE	This enclosed message provides tips for use, care and maintenance of the product.	IMPORTANT	Framed text featuring the word " IMPORTANT " contains important information about the use, checking, maintenance and storage of the product described in this manual.
---	--	-------------	---	------------------	--

Symbols

In this manual and on the product itself, a series of explanatory symbols is used. Please make sure that you fully understand what each symbol means.

Symbol form/shape	Symbol description/application	Symbol form/shape	Symbol description/application
	Carefully read the operator's manual		Petrol and oil mixture
	Wear eyes, ears and head protection		Purge bulb (Primer)
	Safety / Alert	L	Carburettor adjustment - Low speed mixture
	Emergency stop	H	Carburettor adjustment - High speed mixture
	Finger Severing	T	Carburettor adjustment - Idle speed

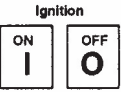
For safe use of your product

Symbol form/shape	Symbol description/applica- tion	Symbol form/shape	Symbol description/applica- tion
	Do not use the product in plac- es with poor ventilation		Choke Control "Cold Start" Position (Choke Closed)
	Beware of fire		Choke Control "Run" Position (Choke Open)
	Beware of electric shocks		Idle speed
	Guaranteed sound power lev- el		Fast speed
	Ignition ON / OFF		Beware of high-temperature areas

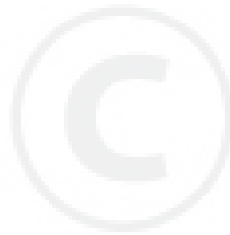

For safe use of your product

Location in which the safety decal is attached

- ♦ The safety decal shown below has been attached to the product described in this manual. Ensure that you understand what the decal means before using your product.
- ♦ If the decal becomes unreadable due to wear and tear or damage, or peels off and is lost, please purchase a replacement decal from your ECHO DEALER and attach it in the location shown in the illustrations below. Ensure that the decal is readable at all times.



1. Safety decal (Part number X505002310)



2. Safety decal (Part number 89016009461)



3. Safety decal (Part number X505001010)

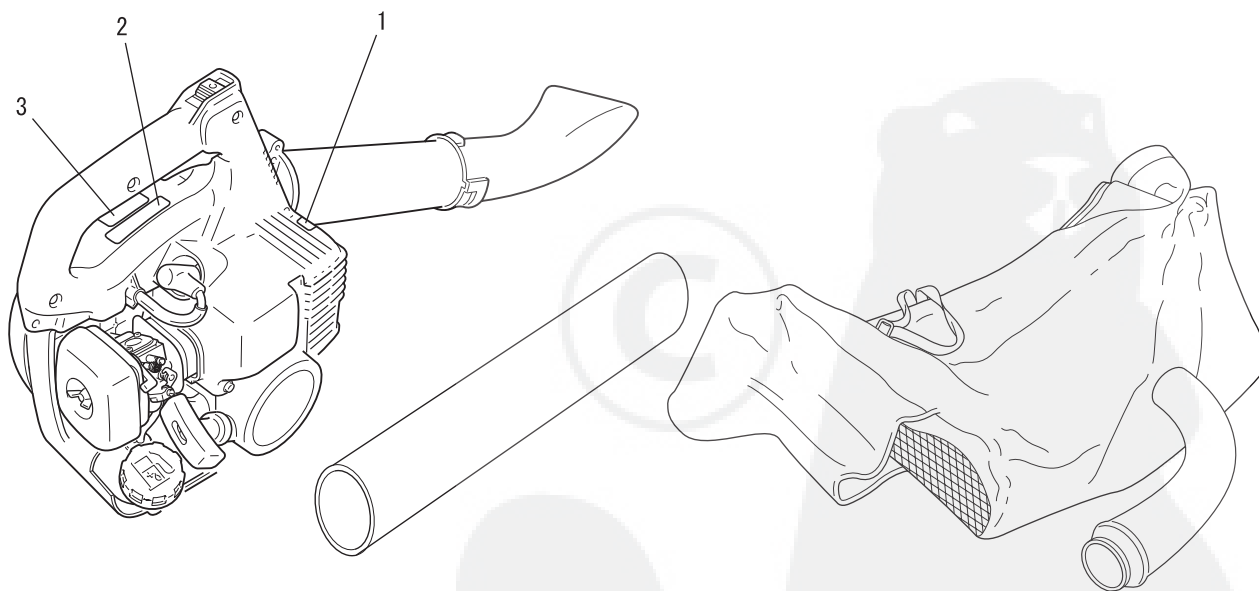

Handling fuel

DANGER

Always keep well away from fire when refuelling

Fuel is highly inflammable and leads to a risk of fire if mishandled. Use extreme care when mixing, storing or handling or serious personal injury may result. Be careful to observe the following instructions.

- Do not smoke or hold a flame near when refuelling.
- Do not fuel up while the engine is hot or in operation.
- ◆ If you do so, the fuel could ignite and cause fire, leading to burns.



About the container and refuelling place

- Use an approved fuel container.
- Fuel tanks/cans may be under pressure.
Always loosen fuel caps slowly allowing pressure to equalize.
- DO NOT fill fuel tanks indoors.
ALWAYS fill fuel tanks outdoors over bare ground.

Fuel spills can cause fire

Observe the following precautions when refuelling:

- Do not add so much fuel that it reaches the mouth of the fuel tank. Keep the fuel within the prescribed level (up to the shoulder level of the fuel tank).
- Mop up any fuel that overflows or spills out due to over-filling.
- Tighten the fuel tank cap securely after refuelling.
- ◆ Fuel spills can cause fire and burns when ignited.

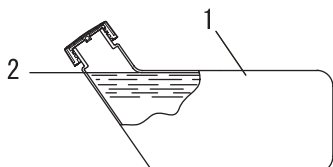

- 1. Fuel tank
- 2. Shoulder level

Do not start the engine in the area where you refueled

- You must not start the engine in the place where you carried out the refuelling. Move at least 3m from the place where you refueled before starting the engine.
- ◆ Fuel leaks that occur while refuelling can cause fire if ignited.

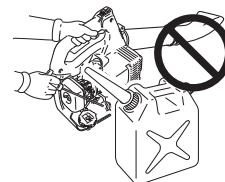

Fuel leaks cause fire

- After refuelling, always check that there are no leaks or discharges of fuel from the fuel pipe, fuel system grommets, or around the fuel tank cap.
- If you do find fuel leaks or discharges, stop using the product immediately and contact your ECHO DEALER to have it repaired.
- ◆ Any fuel leaks could cause fire.

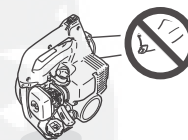

For safe use of your product

Handling the engine

WARNING

Starting the engine

Be particularly careful to observe the following precautions when starting the engine:

- Check that none of the nuts and bolts are loose
- Check that there are no fuel leaks
- Place the product in a flat, well ventilated place
- Leave plenty of space around the product and do not allow people or animals near it
- Remove obstructions, if any
- Start the engine with the throttle lever in the start/operation position
- Hold the product firmly to the ground when starting the engine
- ◆ Failure to observe the precautions could cause an accident or injury, or even lead to a fatality.

Once the engine has started, check for abnormal vibrations and sounds

- Check that there are no abnormal vibrations or sounds once the engine starts. Do not use the product if there are abnormal vibrations or sounds. Contact your ECHO DEALER to have it repaired.
- ◆ Accidents involving parts that fall or shatter off can cause wounds or serious injury.

Do not touch high temperature or high voltage components while the product is running

Do not touch the following high temperature or high voltage components while the product is running or for some time after it stops.

- Muffler, cylinder, and other high temperature components
- ◆ You could burn yourself if you touch a high temperature component.
- Spark plug, spark plug wire, and other high voltage components
- ◆ You could receive an electric shock if you touch a high voltage component while the product is running.



Put safety first in the case of fire or smoke

- If fire comes from the engine or smoke appears from any area other than the exhaust vent, first distance yourself from the product to ensure your physical safety.
- Use a shovel to throw sand or other such material on the fire to prevent it from spreading, or put it out with a fire extinguisher.
- ◆ A panicked reaction could result in the fire and other damage becoming more extensive.



Exhaust fumes are toxic

- The exhaust fumes from the engine contain toxic gases. Do not operate the product indoors or in a plastic greenhouse or in other ill ventilated places.
- ◆ The exhaust fumes could cause poisoning.

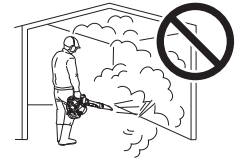

Turn off the engine when checking or maintaining the product

Observe the following precautions when checking and maintaining your product after use:

- Turn the engine off and do not attempt to check or maintain the product until the engine has cooled
- ◆ You could burn yourself.
- Remove the spark plug cap before performing checks and maintenance
- ◆ An accident could occur if the product starts unexpectedly.

Checking the spark plug

Observe the following precautions when checking the spark plug.

- If the electrodes or terminals are worn, or if there are cracks in the ceramics, replace them with new parts.
- The spark test (for checking whether the spark plug is sparking) must be carried out by a professional. Please ask your ECHO DEALER.
- The spark test must not be carried out in proximity of the spark plug hole.
- The spark test must not be performed in places where there are fuel spills or inflammable gases
- You must not touch the metal parts of the spark plug
- ◆ The spark plug could ignite a fire or give you an electric shock.



For safe use of your product

Handling the product General precautions

WARNING

Operator's manual

- Be careful to read the operator's manual properly before using your product in order to ensure correct operation.
- ◆ Failure to do so could lead to an accident or serious injury.



Do not use the product for anything other than its intended purpose

- You must not use the product for any purpose other than those described in the operator's manual.
- ◆ To do so could lead to an accident or serious injury.

Do not modify the product

- You must not modify the product.
- ◆ To do so could lead to an accident or serious injury. Any malfunction resulting from a modification to the product will not be covered by the manufacturer's warranty.

Do not use the product unless it has been checked and maintained

- You must not use the product unless it has been checked and maintained. Always ensure that the product is checked and maintained on a regular basis.
- ◆ Failure to do so could lead to an accident or serious injury.

Loaning or assigning your product

- When loaning your product to another party, ensure that the person borrowing the product receives the operator's manual along with it.
- If you assign your product to another party, please enclose the operator's manual with the product when handing it over.
- ◆ Failure to do so could lead to an accident or serious injury.

Being prepared in case of an injury

In the unlikely event of an accident or injury, please ensure that you are prepared.

- First aid kit
- Towels and wipes (to stop any bleeding)
- Whistle or mobile phone (for calling outside help)
- ◆ If you are unable to perform first aid or call for outside help, the injury could worsen.

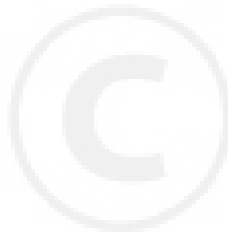
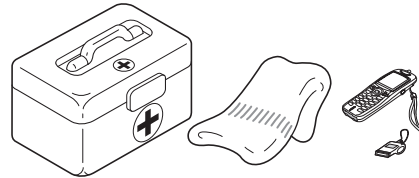

For safe use of your product

Precautions for use

WARNING

Users of the product

The product should not be used by:

- people who are tired
- people who have taken alcohol
- people who are on medication
- people who are pregnant
- people who are in poor physical condition
- people who have not read the operator's manual
- children
- ◆ Failure to observe these instructions could lead to an accident.



Environment of use and operation

- Do not use the product in places where there is no sure foothold, such as on steep slopes or after rainfall, as such places are slippery and dangerous.
- Do not operate the product at night or in dark places with poor visibility.
- ◆ A serious injury could result if you fall or slip, or fail to operate the product correctly.

Using the product

When using the product, pay special attention to observe the following precautions.

- Do not allow people who are irrelevant to the work conducted or animals to be in the worksite.
- Do not point the blower pipe at people or animals.
- Do not use the product in places where there is no sure foothold.
- Hold the arm tightly.
- Avoid using the product late at night or early in the morning so that the neighbors will not be disturbed by noise.
- ◆ Failure to observe these instructions could lead to an accident or injury.

Turn off the engine when moving around

When moving around in the situations described below, turn off the engine and move with the product shouldered.

- Moving to the place where you are working
- Moving to another area while you are working
- Leaving the place where you have been working
- ◆ Failure to observe these precautions could cause burns or serious injury.
- When transporting the product by car, empty the fuel tank, put the product in the upright position, and secure it firmly in place to prevent it from moving around.
- ◆ Travelling by car with fuel in the fuel tank could lead to a fire.

Be careful not to get caught in the fan

- Be careful not to get your hair caught in the fan.
- Never put your hand in between the engine and the backpack frame when the product is in operation.
- ◆ The wind pressure from the fan could make your hand get caught in the fan, resulting in a serious injury.

Vibration and cold

It is believed that a condition called Raynaud's Phenomenon which affects the fingers of certain individuals may be brought about by exposure to vibration and cold. Exposure to vibration and cold may cause tingling and burning, followed by loss of colour and numbness in the fingers. The following precautions are strongly recommended because the minimum exposure which might trigger the ailment is unknown.

- Keep your body warm, especially the head and neck, feet and ankles, and hands and wrists.
- Maintain good blood circulation by performing vigorous arm exercises during frequent work breaks, and also by not smoking.
- Limit the number of hours of operation.
Try to fill each day with jobs where operating the blower or other hand-held power equipment is not required.
- If you experience discomfort redness and swelling of the fingers, followed by whitening and loss of feeling, consult your physician before exposing yourself further to cold and vibration.
- ◆ Failure to observe these instructions could result in damage to your health.

For safe use of your product

WARNING

Repetitive stress injuries

It is believed that over-using the muscles and tendons of the fingers, hands, arms and shoulders may cause soreness, swelling, numbness, weakness and extreme pain to the areas just mentioned. Certain repetitive hand activities may put you at a high risk for developing a repetitive stress injury (RSI).

To reduce the risk of RSI, do the following:

- Avoid using your wrist in a bent, extended or twisted position.
- Take periodic breaks to minimize repetition and rest your hands. Reduce the speed and force in which you do the repetitive movement.
- Do exercises to strengthen hand and arm muscles.
- See a doctor if you feel tingling, numbness or pain in your fingers, hands, wrists or arms. The sooner RSI is diagnosed, the more likely permanent nerve and muscle damage can be prevented.
- ◆ Failure to observe these instructions could result in damage to your health.

Turn off the engine immediately if anything goes wrong

- Turn off the engine immediately if the product suddenly starts to emit abnormal sounds or vibrate abnormally. The product cannot be used when it suffers from abnormal vibration or sounds. Contact your ECHO DEALER for repair.
- ◆ Continuing to use parts when they are damaged could lead to an accident or serious injury.

Protective gear

WARNING

Wear protective gear

- Wear appropriate work clothes and protective gear when working with the power blower. Above all, make sure to wear safety goggles, a dust mask, and ear muffs at all times while working.

◆ Without the protective gear, you could inhale the debris or dust blown away or get them in your eyes, which could lead to an accident or injury.

- a **Head protection (helmet):** Protects the head
- b **Ear muffs or ear plugs:** Protect the hearing
- c **Safety goggles:** Protect the eyes
- d **Dust mask**
- e **Safety gloves:** Protect the hands from cold and vibration
- f **Work clothes that fit (long sleeves, long trousers):** Protect the body
- g **Heavy duty, non-slip protective boots (with toecaps) or non-slip work shoes (with toecaps):** Protect the feet
- ◆ Failure to observe these precautions could result in damage to your sight or hearing, or lead to a serious injury.

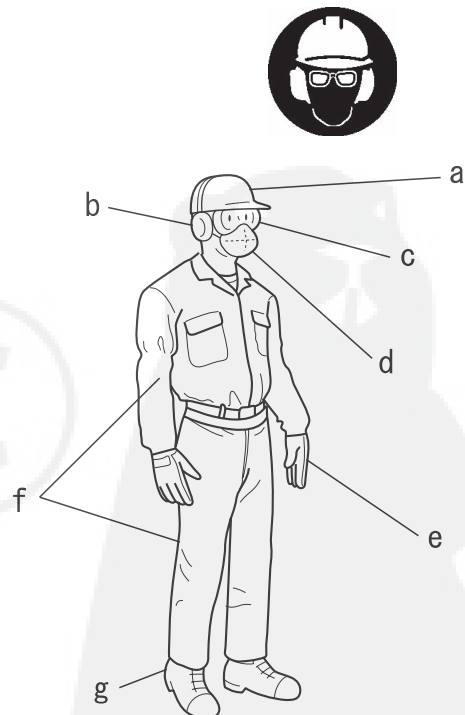

Wear proper clothing.

Do not wear ties, jewellery, or loose, dangling clothing which could be caught in the unit. Do not wear open toed footwear, or go bare-foot or barelegged. In certain situations, total face and head protection may be required.

- ◆ Failure to observe these precautions could result in damage to your sight or hearing, or lead to a serious injury.



Packing list

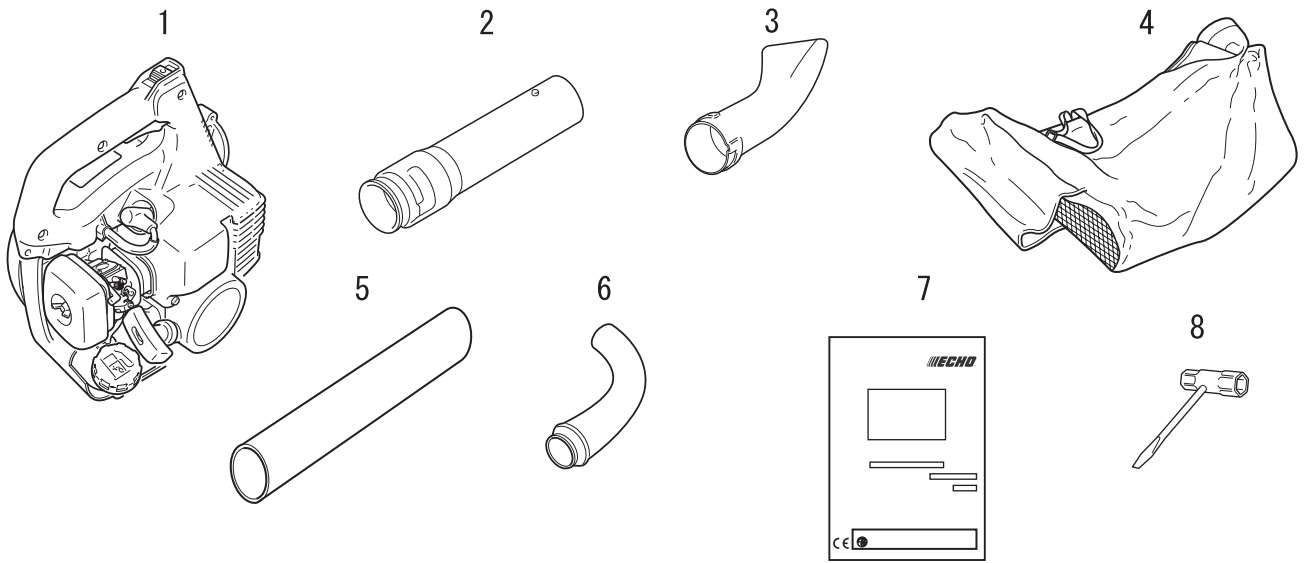

- ♦ The following parts are packed separately in the packing box.
- ♦ When you have unpacked the box, please check the parts that it contains.
- ♦ Contact your ECHO DEALER if anything is missing or broken.



Number	Part name	Quantity	Number	Part name	Quantity
(1)	Power Head	1	(5)	Vacuum Tube	1
(2)	Straight Pipe	1	(6)	Vacuum Elbow	1
(3)	Fan Head Nozzle	1	(7)	Operator's Manual	1
(4)	Debris Bag	1	(8)	T-Wrench	1

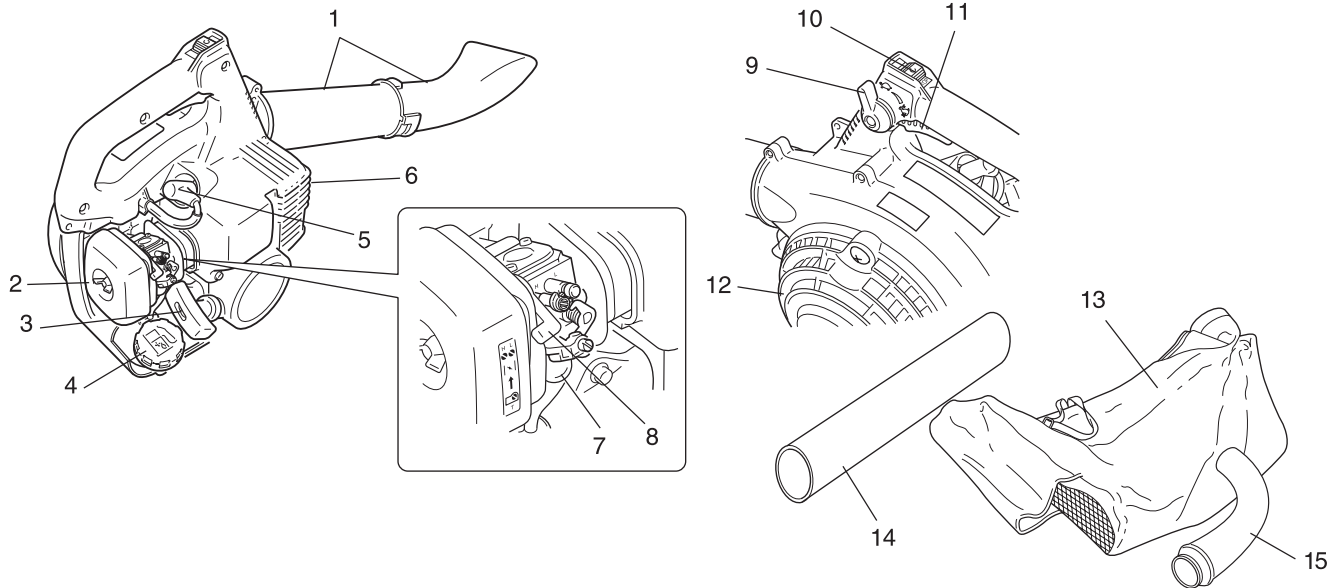



1. **Blower pipes** Exclusive positive locking system.
2. **Air cleaner** Contains replaceable air filter element.
3. **Starter handle** Pull recoil handle slowly until recoil starter engages, then quickly and firmly. When engine starts, return handle slowly. DO NOT let handle snap back or damage to unit will occur.
4. **Fuel tank cap** Covers and seals fuel tank.
5. **Spark plug** Provides spark to ignite fuel mixture.
6. **Spark arrestor - Catalytic muffler / Muffler** The muffler or catalytic muffler controls exhaust noise and emission. The spark arrestor screen prevents hot, glowing particles of carbon from leaving the muffler. Keep exhaust area clear of flammable debris.
7. **Purge bulb** Pumping purge bulb before starting engine draws fresh fuel from the fuel tank, purging air from the carburetor. Pump purge bulb until fuel is visible and flows freely in the clear fuel tank return line. Pump purge bulb an additional 4 or 5 times.
8. **Choke** Choke is located on top of the air cleaner. Move choke lever to  position to close choke for cold starting. Move choke lever to  position to open choke.
9. **Throttle position lever** Pull back to increase engine speed. Friction washers maintain throttle lever setting.
10. **Stop switch** "SLIDE SWITCH" mounted on top of handle. Push forward to start and run. Slide back to stop.
11. **Throttle trigger** Spring loaded to return to idle when released. During acceleration, press trigger gradually for best operating technique.
12. **Housing cover** Covers blade area and activates safety interlock switch when closed. Engine will not run if safety switch is not activated.
13. **Debris bag** Collects shredded material.
14. **Vacuum tube** Sucks in materials to be shredded.
15. **Vacuum elbow** Discharges shredded material.

Before you start

Assembly

WARNING

- Read the operator's manual carefully to ensure that you assemble the product correctly.
- Never perform maintenance or assembly procedures with engine running.
- ◆ Using a product that has been incorrectly assembled could lead to an accident or serious injury.



Install vacuum tube

1. Turn screw anticlockwise until hinged housing cover is free to open for vacuum tube installation.

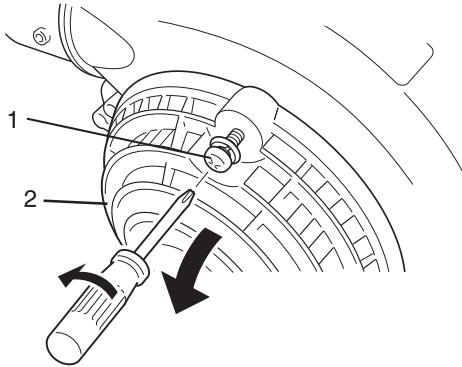

1. Screw

2. Housing cover

2. While holding housing cover open, install vacuum tube into blower housing with bevel end facing downward.
3. Secure vacuum tube with clamp.

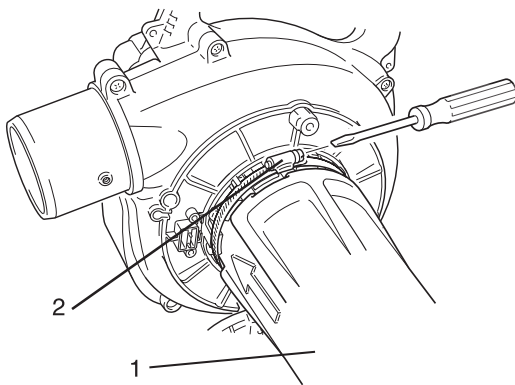

1. Vacuum tube

2. Clamp

NOTE

Clamp fits under slotted guide.

Install debris bag

1. Remove pipe retaining screw from blower housing. Align grooves in vacuum elbow (A) with pegs (B) on blower housing and install vacuum elbow.
2. Turn vacuum elbow anticlockwise to lock it into place.

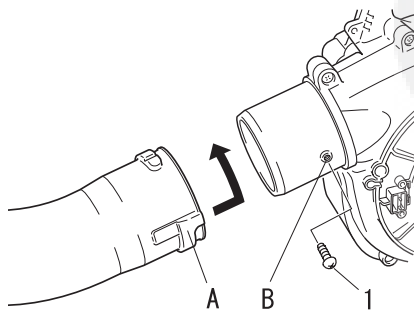

1. Screw

Before you start

3. Tighten screw securely.

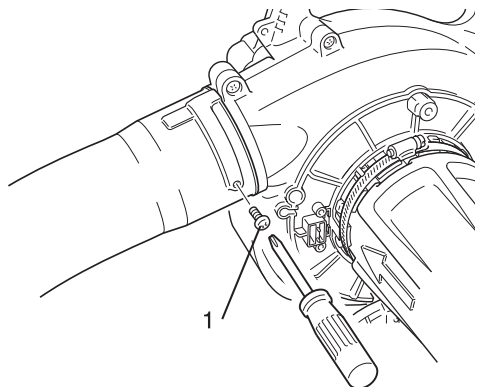

1. Screw

4. Place debris bag opening over flared end of vacuum elbow, and cinch debris bag securely with velcro strap (C).

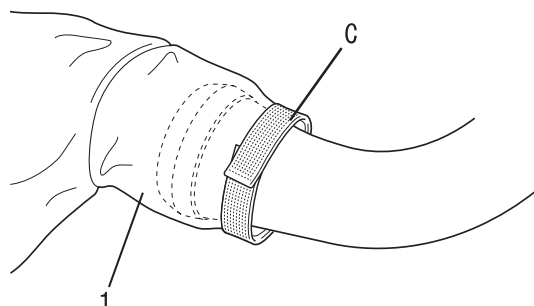

1. Debris bag

Install blower pipes for blower usage

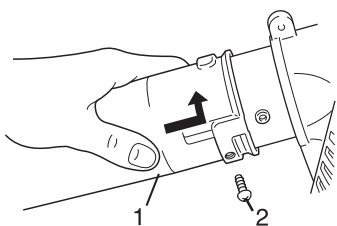

1. Straight pipe

2. Screw

1. Remove pipe retaining screw from blower housing. Align grooves in straight pipe with pegs of blower housing and slide pipe onto housing.
2. Turn straight pipe clockwise to lock it into place.

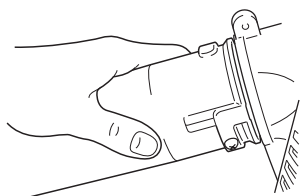

3. Tighten screw securely.
4. Remove pipe retaining screw from the straight pipe. Align grooves in fan head nozzle with pegs on straight pipe and slide fan head nozzle onto straight pipe.
5. Turn fan head nozzle clockwise to lock it into place.
6. Tighten the screw on fan head nozzle securely.

Before you start

Preparing the fuel

DANGER

- Fuel is highly inflammable and there is a risk of fire if it is handled incorrectly. Carefully read and observe the precautions in the section of this manual titled "For safe use of your product".
- Once the refuelling is complete, securely tighten the fuel tank cap and do not forget to check that there are no leaks or discharges of fuel from the fuel pipe, fuel system grommets, or around the fuel tank cap. If you do find fuel leaks or discharges, stop using the product immediately and contact your ECHO DEALER to have it repaired.
- ◆ If the fuel ignites, it could cause burns and fire.



CAUTION

There is difference in pressure between the fuel tank and the outside air. When refuelling, loosen the fuel tank cap slightly to eliminate the difference in pressure.

- ◆ Otherwise, fuel may get spewed.

NOTE

Stored fuel ages. Do not mix more fuel than you expect use in thirty (30) days. Do not mix directly in fuel tank.

Fuel



- ◆ Fuel is a mixture of regular grade petrol and an air-cooled 2-stroke engine oil of reputable brand name. Minimum 89 Octane unleaded petrol is recommended. Do not use fuel containing methyl alcohol or more than 10 % of ethyl alcohol.
- ◆ Recommended mixture ratio; 50 : 1 (2 %) for ISO-L-EGD Standard (ISO/CD 13738), JASO FC,FD grade and ECHO Premium 50 : 1 oil.
 - Do not mix directly in engine fuel tank.
 - Avoid spilling petrol or oil. Spilling fuel should always be wiped up.
 - Handle petrol with care, it is highly inflammable.
 - Always store fuel in approved container.

Fuel supply

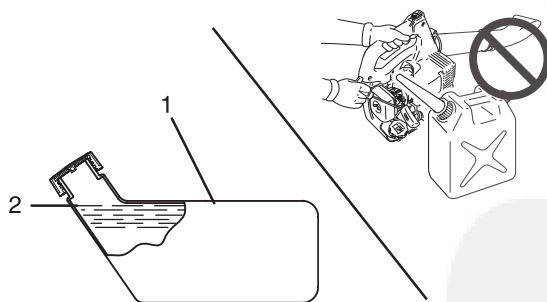

1. Fuel tank

2. Shoulder level

- ◆ Always refuel in a well ventilated location. Do not pour fuel indoors.
- ◆ Place the product and the refuelling tank on the ground when performing the refuelling operation. Do not refuel the product on the loading platform of a truck, or in other such places.
- ◆ Always ensure that the fuel level remains below the shoulder level of the fuel tank when refuelling.
- ◆ There is a difference in pressure between the fuel tank and the outside air. When refuelling, loosen the fuel tank cap slightly to eliminate the difference in pressure.
- ◆ Always wipe up any fuel spills.
- ◆ Move at least 3m away from where you refueled before you start the engine.
- ◆ Keep the refuelling tank in a shaded area away from fire.

Starting the engine

WARNING

- When starting the engine, observe the precautions described from Page 4 in the section "For safe use of your product" to ensure that you operate the product correctly.
- ◆ Failure to observe the precautions could cause an accident or injury, or even lead to a fatality.

NOTE

- ◆ Pull out the starter grip gently at first, and then more rapidly. Do not pull the starter rope out to more than 2/3 of its length.
- ◆ Do not let go of the starter grip as it returns.
- ◆ To start the engine, return the choke knob when you hear the first explosion-like sound and pull on the starter grip again. Be careful not to miss the first explosion-like sound.

Starting a cold engine

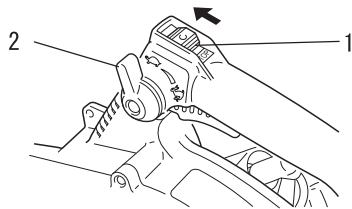

1. Stop switch 2. Throttle position lever

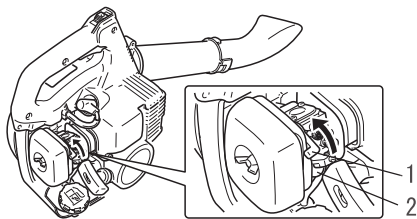

1. Choke 2. Purge bulb

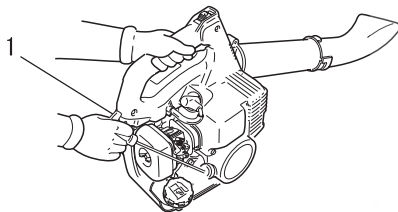

1. Recoil starter

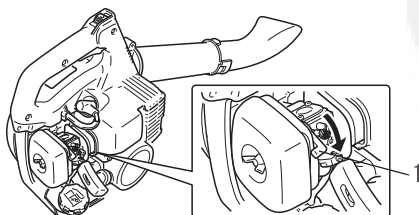

1. Choke

- ◆ Recoil starter: Use short pulls - only 1/2-2/3 of rope length for starting. Do not allow the rope to snap back in. Always hold the unit firmly.

1. *Stop Switch*
Move stop switch away from the STOP position.
2. *Throttle Position Lever*
Move throttle position lever midway between idle and full throttle positions.
3. *Choke*
Move choke to "" position.
4. *Purge Bulb*
Pump purge bulb until fuel is visible and flows freely in the clear fuel tank return line.

5. *Recoil Starter*
Place the unit on a flat, clear area. Firmly grasp throttle grip with left hand and rapidly pull recoil starter handle/rope until engine fires, or maximum 5 pulls.

6. *Choke*
Move choke to "" position and if necessary, restart engine.

NOTE

If engine does not start after 5 pulls, repeat instructions 3-6.

After engine warm up, gradually depress throttle trigger to increase engine RPM to operating speed.

NOTE

Allow engine to warm up before use.

Engine operation

Engine warm-up

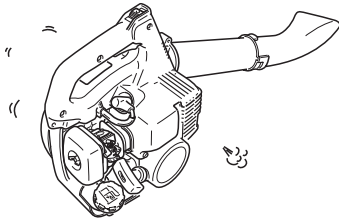

1. Once the engine starts, allow it to warm up for 2 to 3 minutes at idling (i.e. low speed).
2. Warming the engine helps to lubricate its internal workings more smoothly. Allow the engine to warm up fully, especially when it is cold.
3. Never run the engine without the blower pipes fitted.

Starting a warm engine

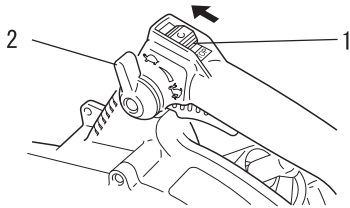

1. Stop switch
2. Throttle position lever

♦ The starting procedure is the same as Cold Start except DO NOT close the choke.

1. *Stop Switch*
Move stop switch away from the STOP position.
2. *Throttle Position Lever*
Move throttle position lever midway between idle and full throttle positions.

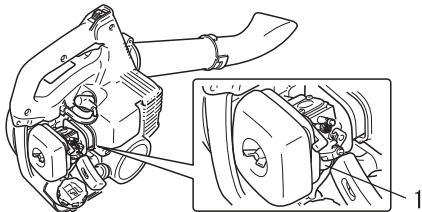

1. Purge bulb

3. *Purge Bulb*
Pump purge bulb until fuel is visible and flows freely in the clear fuel tank return line.

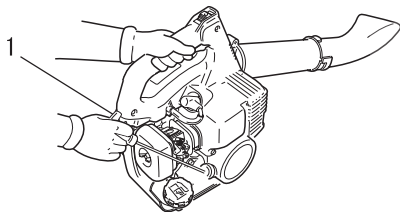

1. Recoil starter

4. *Recoil Starter*
Place the unit on a flat, clear area. Firmly grasp throttle grip with left hand and rapidly pull recoil starter handle/rope until engine fires.

Stopping the engine

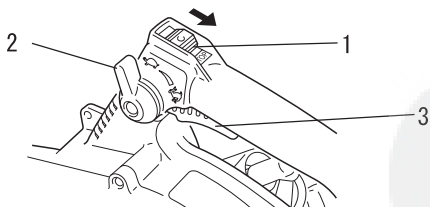

1. Stop switch
2. Throttle position lever
3. Throttle trigger

1. *Throttle Position Lever*
Release throttle trigger. Move throttle position lever forward to idle position and allow engine to return to idle before shutting off engine.
2. Move stop switch to STOP position.

NOTE

If engine does not start after 5 pulls, use cold start procedures.

WARNING

If engine does not stop when stop switch is moved to STOP position, close choke -  position - to stall engine. Have your ECHO dealer repair stop switch before using blower again.

Operating vacuum

-SHRED'N'VAC® Operation-

⚠ DANGER

Flying debris hazard. Never operate unit as a vacuum unless discharge elbow is installed and debris bag is securely cinched to elbow. Failure to follow instructions can result in serious injuries.

NOTE

Vacuum action works best at higher engine speeds. Avoid using vacuum in areas where rocks or other large, hard debris may be vacuumed into unit. Clear these areas with blower first, blowing light debris into a pile. Use attachment to vacuum pile.

Be aware that fan or fan case will rapidly wear if unit vacuums up abrasive objects such as sand, dirt mixed with sand, or crushed stones. Also, vacuuming up sticky material like mud or fallen leaves turning to leaf mold may cause fan case or pipe to clog. Contact the local ECHO dealer in your area should you notice a significant decrease in suction power or abnormal vibrations using your unit.

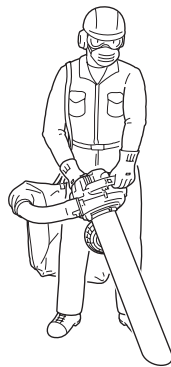

1. Adjust debris bag strap to support bag on operator's shoulder. Bag must not be folded at intake area, or intake will clog. Further adjustment may be necessary as the debris bag fills and becomes heavier.
2. Grip top handle with left hand, and rear handle with right hand. Keep unit to your right side so hot exhaust will be directed away from you.
3. Operate unit with beveled end of tube facing downward. Keep tube opening close to material being vacuumed for best results.
4. Empty bag when debris level reaches intake opening. To empty bag, move stop switch to "Stop" position, and wait for blower to stop running. Loosen Velcro strap at elbow and slide bag off elbow. Open other end of bag, and empty contents. Close bag, and reattach to blower. Secure bag with Velcro strap.

-SHRED'N'VAC® Troubleshooting-

Problem	Cause	Solution
Unit runs, but doesn't vacuum or has poor suction.	Elbow or debris bag clogged.	Check elbow and debris bag, and clear as needed. Make sure bag is not folded over at intake during use.
	Obstructions in vacuum tube.	Check vacuum tube, and remove obstructions. Avoid wet leaves.
Unit stopped suddenly during vacuuming, and now starter won't work.	Object stuck in fan housing area.	Remove vacuum tube and check fan area. Remove object.
Unit jams repeatedly during use.	Material being vacuumed too big or too hard for blades to shred.	Use vacuum for leaves and small twigs, maximum 1/4" diameter x 3" long.

Operation

Operating blower

WARNING

Always wear safety glasses, hearing protection, face filter mask and take all safety precautions or serious personal injury may result. Do not point the blower pipe in the direction of people or pets.

IMPORTANT

To avoid engine damage due to over revving, do not block blower pipe opening.

NOTE

Never use a higher speed setting than necessary to perform a task. Remember, the higher the engine speed, the louder the blower noise. Minimize dust by using blower at lower speeds. Keep debris on your property. Be Smart - be a good neighbor.

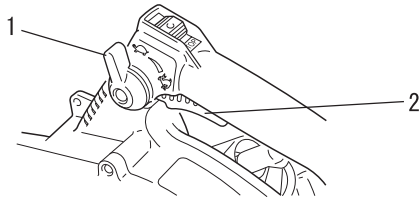

1. Throttle position lever 2. Throttle trigger

♦ Read the Safty Section carefully.

1. Use only during appropriate hours.
2. Allow the engine to warm up at a fast idle for a few minutes.
3. Control engine speed with throttle trigger, or for continuous use, set engine speed with throttle position lever. Rotate throttle position lever forward for lower speed, back for higher speed.
4. Use lower speed to blow debris from hard surfaces.
5. Additional speed may be necessary to clean debris, snow, etc. from lawns and flowerbeds.

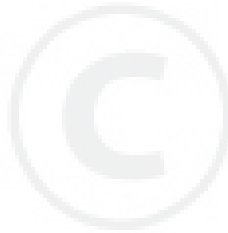
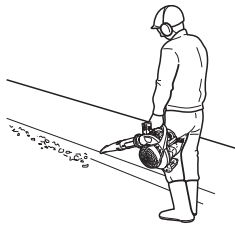
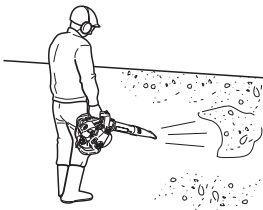

Maintenance and care

Servicing guidelines

Area	Maintenance	Page	Before use	Monthly
Air filter	Inspect/Clean/Replace	21	•	
Fuel filter	Inspect/Replace	22	•	
Spark plug	Inspect/Clean/Adjust/Replace	26		•
Carburettor	Inspect	22		•
Cooling system	Inspect/Clean	24	•	
Exhaust system	Inspect/Tighten/Clean	25	•	
Starter	Inspect	-	•	
Fuel system	Inspect	-	•	
Screws, bolts and nuts	Inspect/Tighten/Replace	-	•	

IMPORTANT

Time intervals are maximum. Actual use and your experience will determine the frequency of required maintenance.

Maintenance and care

If you have any questions or problems, please contact your ECHO DEALER.

Cleaning air filter



Tools required: 25-50 mm (1-2 in.) Cleaning brush
Parts required: Air filter

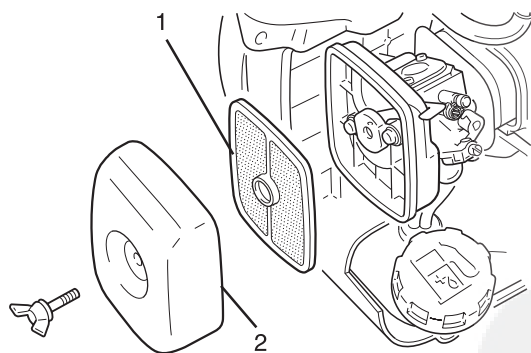

1. Air filter

2. Air filter cover

1. Close choke (). This prevents dirt from entering the carburetor throat when the air filter is removed.
2. Remove air filter cover. Brush dirt from inside cover.
3. Remove air filter and lightly brush debris from filter. Replace filter if it is damaged, fuel soaked, very dirty, or the rubber sealing edges are deformed.
4. If filter can be reused, be certain it:
 - ♦ Fits tightly in the air filter cavity.
 - ♦ Is installed with the original side out.
5. Install air filter cover.

Maintenance and care

Replacing fuel filter

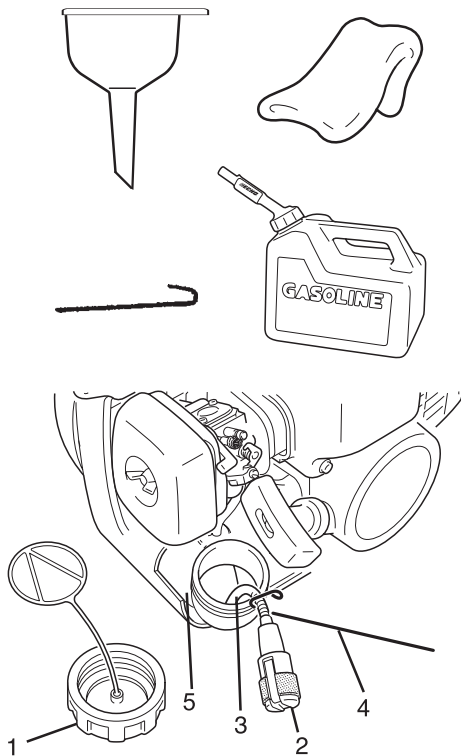

1. Fuel cap
2. Fuel filter
3. Fuel line
4. Fuel line hook
5. Fuel tank

Tools required: 200-250 mm (8-10 in.) length of wire with one end bent into a hook, clean rag, funnel, and an approved fuel container
Parts required: Fuel line and filter

⚠ DANGER

Fuel is **VERY** flammable. Use extreme care when mixing, storing or handling.

NOTE

If filter is excessive dirty or no longer fits properly, replace it.

1. Use a clean rag to remove loose dirt from around fuel cap and empty fuel tank.
2. Use the "fuel line hook" to pull the fuel line and filter from the tank.
3. Remove the filter from the line and install the new filter.

Carburettor adjustment

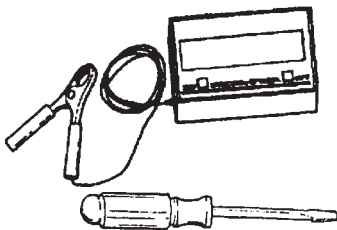

Engine Break-In

New engines must be operated a minimum duration of two tanks of fuel break-in before carburetor adjustments can be made. During the break-in period your engine performance will increase and exhaust emissions will stabilize. Idle speed can be adjusted as required.

High Altitude Adjustment

This engine has been factory adjusted to maintain satisfactory starting, emission, and durability performance up to 1,000 feet above mean sea level (MSL). To maintain proper engine operation above 1,000 feet MSL the carburetor must be adjusted by an authorized ECHO service dealer.

Tools required: Screwdriver, tachometer (Echo P/N 99051130017)
Parts required: None

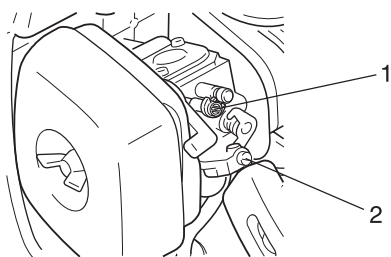

1. HI speed needle

2. IDLE speed adjustment
Screw

IMPORTANT

If the engine is adjusted for operation above 1,000 feet MSL, the carburetor must be re-adjusted when operating the engine below 1,000 feet MSL, otherwise severe engine damage can result.

NOTE

Every unit is run at the factory and the carburetor is set in compliance with Emission Regulations. This carburetor does not have acceleration adjustment needles.

Before Adjustment

Check that:

- Air filter is clean and properly installed.
- Spark arrestor screen is free of carbon.
- Blower pipes are installed.

- Before adjusting the carburetor, clean or replace the air filter and spark arrestor screen and install blower pipes.
- Start engine and run for several minutes to reach operating temperature.
- Stop engine. Turn red HI speed needle CCW (counter clockwise) to stop.
- Idle Speed Adjustment with tachometer.
 - Start engine and turn "idle" speed adjustment screw to idle RPM found "Specifications" on page 28 of this manual.
- Accelerate to full throttle for 2-3 seconds to clear excess fuel from engine then return to idle. Accelerate to full throttle to check for smooth transition from idle to full throttle. If engine stops or stalls after full warm up, return the unit to your authorized ECHO dealer for repair.
- Check HI speed RPM at W.O.T. (Wide Open Throttle). HI speed RPM should be set to specifications found "Specifications" on page 28 of this manual.
- Check idle speed and reset if necessary.

Maintenance and care

Cooling system maintenance

IMPORTANT

To maintain proper engine operating temperature, cooling air must pass freely through the cylinder fin area. This flow of air carries combustion heat away from the engine.

Overheating and engine seizure can occur when:

- ♦ Air intakes are blocked, preventing cooling air from reaching the cylinder,

or

- ♦ Dust and grass build up on the out side of the cylinder. This build-up insulates the engine and prevents the heat from leaving. Removal of cooling passage blockages or cleaning of cylinder fins is considered "Normal Maintenance". Any resultant failure attributed to lack of maintenance is not warranted.

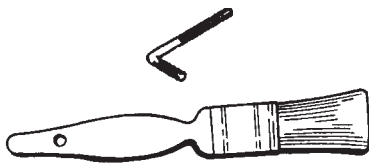

Tools required: 3mm hex wrench, cleaning brush, cross head screwdriver

Parts required: None, if you are careful.

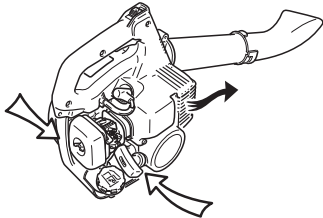

Cleaning Grill

1. Brush accumulated debris from crankcase intake grill above the fuel tank.

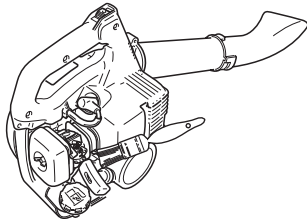

IMPORTANT

Do not over-tighten screws, otherwise mounting holes may become stripped.

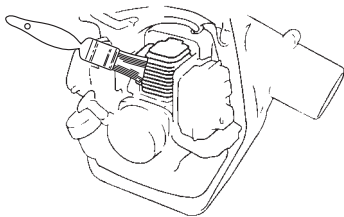

Cleaning Cylinder Fins

1. Remove spark plug lead and spark plug.
2. Remove four 3 mm hex screws, side handle and recoil starter.
3. Remove engine cover (five screws), pull cover away from engine. Loosely install spark plug to prevent dirt from entering cylinder. Clean cylinder fins to allow cooling air to pass freely.
4. Remove spark plug and loosely reassemble engine cover, recoil starter, and side handle.
5. Tighten all screws securely.
6. Install spark plug and spark plug lead.

Maintenance and care

Exhaust system

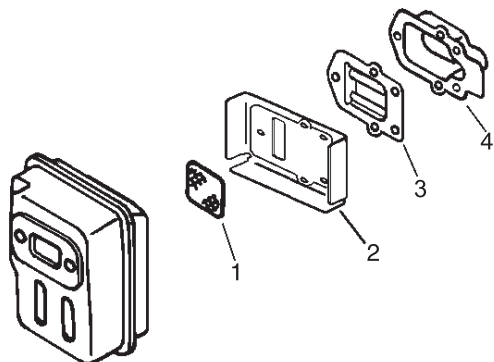
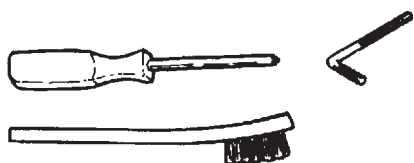

- 1. Spark arrester screen
- 2. Gasket
- 3. Spark arrester cover
- 4. Exhaust deflector

Spark Arrester Screen

Tools required: Cross Head Screwdriver, 3 mm Hex Wrench, Soft metal brush

Parts required: Spark arrester screen, Gasket

IMPORTANT

Carbon deposits in muffler will cause a drop in engine output and overheating. Spark arrester screen must be checked periodically.

1. Remove spark plug lead and spark plug.
2. Remove two upper 3 mm hex screws at recoil starter.
3. Remove five engine cover screws and remove cover from engine.
4. Remove spark arrester covers, gasket and spark arrester screen from muffler. Replace screen if plugged with carbon deposits.
5. Install spark arrester screen, gasket, and covers.
6. Loosely reassemble engine cover with five cross head and two hex head screws.
7. Tighten all screws securely.
8. Install spark plug and spark plug lead.

NOTE

When cleaning carbon deposits, be careful not to damage the catalytic element inside muffler.

Cylinder Exhaust Port

IMPORTANT

The cylinder exhaust port must be inspected and cleaned of excess carbon every 3 months or 90 hours of operation in order to maintain this engine within the emissions durability period. ECHO strongly recommends that you return your unit to your ECHO dealer for this important maintenance service.

Maintenance and care

Check spark plug

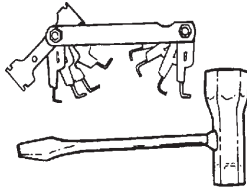

Tools required: T-Wrench, Feeler gauge
Parts required: Spark plug

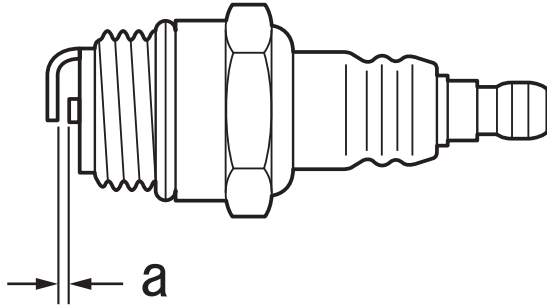

a: 0.6 - 0.7 mm

IMPORTANT

Use only NGK BPMR8Y spark plug otherwise severe engine damage may occur.

1. Check plug gap. Correct gap is 0.6 mm to 0.7 mm.
2. Inspect electrode for wear.
3. Inspect insulator for oil or other deposits.
4. Replace plug if needed and tighten to 15 N·m - 17 N·m (150 kgf·cm to 170 kgf·cm).

Troubleshooting table

Problem	Diagnosis	Cause	Solution
Engine is difficult to start, fluctuating rotation or The engine does not start	No fuel is entering the overflow pipe	Fuel filter is clogged Fuel system is clogged Internal carburettor parts sticking	Clean or replace Clean Consult your ECHO DEALER
	Fuel is entering the overflow pipe	Fuel degradation Carburettor problem	Replace with new fuel Consult your ECHO DEALER
	The crankshaft does not rotate	Internal engine malfunction	Consult your ECHO DEALER
	The spark plug is dirty or damp	Fuel degradation Incorrect electrode gap Carbon deposits Electrical fault	Replace with new fuel Adjust or Replace Clean or Replace Consult your ECHO DEALER
Engine starts but no acceleration is possible		Dirty air filter Dirty fuel filter Blocked fuel passage Carburettor adjustment problem Spark plug problem Blocked exhaust vent or silencer vent Spark arrestor screen plugged or normal wear	Clean or replace Clean or replace Consult your ECHO DEALER Consult your ECHO DEALER Clean, Adjust or Replace Clean Clean or replace

- ♦ Checking and maintenance requires specialist knowledge. If you are unable to check and maintain the product or deal with a fault yourself, consult your ECHO DEALER. Do not attempt to dismantle the product.
- ♦ Consult your ECHO DEALER in the event of a problem that is not covered in the table above, or other such concerns.
- ♦ For spare parts and consumables, please use only genuine parts and designated products and components. Using parts from other manufacturers or non-designated components may result in a malfunction.

Maintenance and care

Long-term storage(30 days or more)

WARNING

During operation the muffler - catalytic muffler and surrounding cover become hot. Always keep exhaust area clear of flammable debris during transportation or when storing, otherwise serious property damage or personal injury may result.



Do not store your unit for a prolonged period of time (30 days or longer) without performing protective storage maintenance which includes the following:

1. Store unit in a dry, dust free place, out of the reach of children.

WARNING

Do not store where fuel fumes may accumulate or reach an open flame or spark.

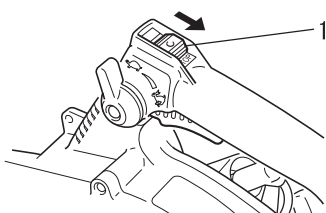

1. Stop switch

2. Place the stop switch in the "STOP" position.
3. Remove accumulation of grease, oil, dirt and debris from exterior of unit.
4. Perform all periodic lubrication and services that are required.
5. Tighten all screws and nuts.
6. Drain the fuel tank completely and pull the recoil starter handle several times to remove fuel from the carburetor.
7. Remove the spark plug and pour 10mL of fresh, clean ECHO 2-stroke engine oil into the cylinder through the spark plug hole.
 - A. Place a clean cloth over the spark plug hole.
 - B. Pull the recoil starter handle 2-3 times to distribute the oil inside the engine.
 - C. Observe the piston location through the spark plug hole. Pull the recoil handle slowly until the piston reaches the top of its travel and leave it there.
8. Fit the spark plug. (Do not connect the spark plug cap.)
9. Remove blower pipe assembly from unit.

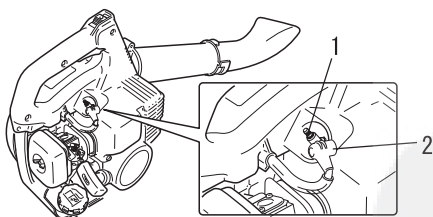

1. Spark plug

2. Spark plug cap

Please contact your ECHO DEALER in order to dispose of the product or its parts in compliance with national laws.

Specifications

		PB-2350
Mass (Dry , without pipes):	kg	4.0
External dimensions (without pipes): Length Width Height	mm mm mm	330 280 340
Engine: Type Engine displacement Maximum power Engine speed at maximum engine power Recommended maximum engine speed Recommended engine idling speed Carburettor Ignition Spark plug Starter	mL (cm ³) kW r/min r/min r/min	Air cooled 2-stroke single cylinder 21.2 0.6 8000 7500 2900 Diaphragm type Flywheel magneto - CDI system NGK BPMR8Y Automatic recoil system
Air Volume with fan head nozzle: Air speed with fan head nozzle:	m ³ /min m/s	7.5 59
Fuel: Oil Ratio		Regular grade petrol. Minimum 89 Octane unleaded petrol is recommended. Do not use fuel containing methyl alcohol or more than 10 % of ethyl alcohol. Two stroke, air-cooled engine oil. ISO-L-EGD Standard (ISO/CD 13738), JASO FC,FD grade and ECHO Premium 50 : 1 oil. 50 : 1 (2%)
Tank Capacity:	L	0.5
Sound pressure level: (ISO 22868) LpAav =	dB(A)	86
Guaranteed sound power level: (2000/14/EC) L _{WA} =	dB(A)	107
Vibration levels: (ISO 22867)	m/s ²	9.0

These specifications are subject to change without notice.

Declaration "CE" of conformity

The undersigned manufacturer:

KIORITZ CORPORATION
7-2 SUEHIROCHO 1-CHOME
OHME; TOKYO 198-8711
JAPAN

declares that the hereunder specified new unit:

POWER BLOWER

Brand: ECHO
Type: PB-2350

assembled by:

ECHO, INCORPORATED
400 Oakwood Road
Lake Zurich, Illinois 60047-1564
U.S.A.

complies with:

- * the requirements of Directive **98/37/EC (1998)**
- * the requirements of Directive **2004/108/EC**
(use of harmonized standards **EN 50081-1, EN 50082-1, EN 55014 and EN 55022**)
- * the requirements of Directive **2002/88/EC**
- * the requirements of Directive **2000/14/EC**

Conformity assessment procedure followed **ANNEX V**

Measured sound power level : **104dB(A)**

Guaranteed sound power level : **107dB(A)**

PB-2350 Serial Number 37001001 and up

Tokyo,
February 1st 2008

KIORITZ CORPORATION

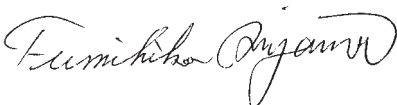

F. Aiyama **General Manager**

Authorized Representative in Europe:

Company: Countax Limited

Address: Countax House, Haseley Trading Estate,
Great Haseley, Oxfordshire OX44 7PF, U.K.

Mr. Harry Handkammar

MEMORANDUM



MEMORANDUM





KIORITZ CORPORATION

7-2 SUEHIROCHO 1-CHOME, OHME, TOKYO 198-8711, JAPAN
PHONE: 81-428-32-6118. FAX: 81-428-32-6145.

ECHO®

ECHO, INCORPORATED
400 Oakwood Road,
Lake Zurich Illinois 60047-1564
U.S.A.



X753-003 60 0

X753 113-750 0