

USO · MANUTENZIONE · RICAMBI  
EMPLOI · ENTRETIEN · PIEGES DETACHEES  
USE · MAINTENANCE · SPARE PARTS  
BEDIENUNG · WARTUNG · ERSATZTEILE  
EMPLEO · MANTENIMIENTO · REPUESTOS

# VT 88 W - VT 94 W

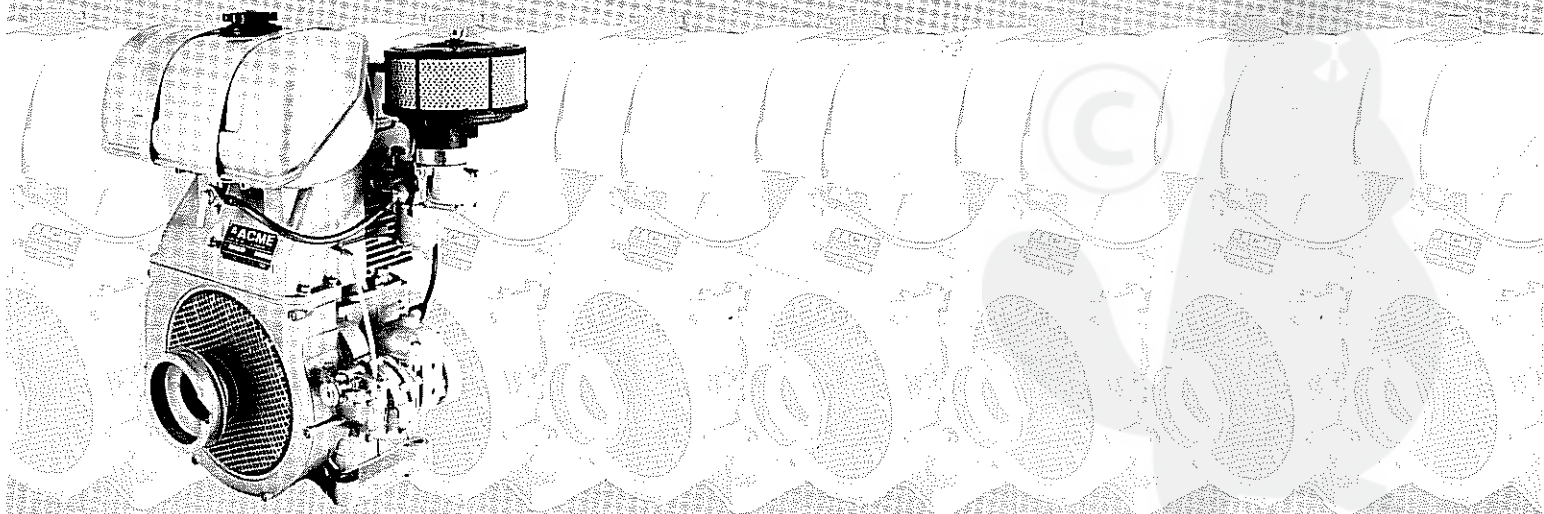

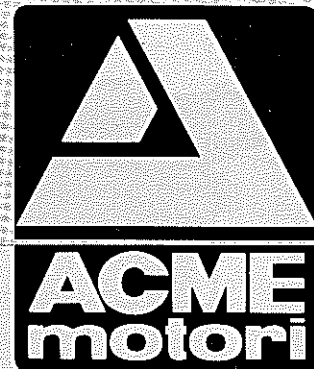
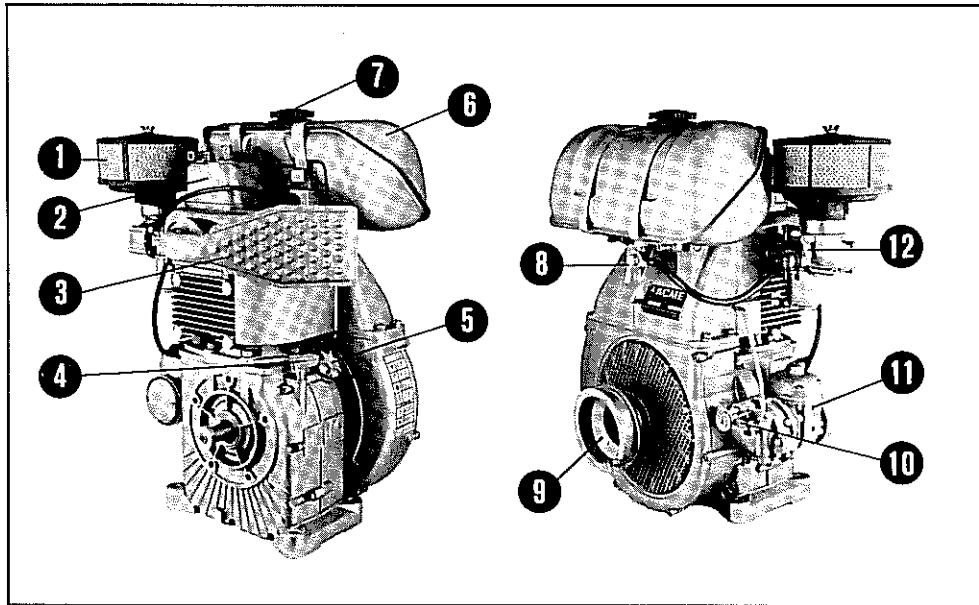

- 1) Filtro aria
- 2) Coperchio bilancieri
- 3) Marmitta
- 4) Asta livello olio
- 5) Tappo rifornimento olio
- 6) Serbatoio
- 7) Tappo serbatoio
- 8) Rubinello
- 9) Puleggia avviamento
- 10) Leva acceleratore
- 11) Magnete
- 12) Starter

- 1) Filtre à air
- 2) Couvercle culbuteurs
- 3) Pot d'échappement
- 4) Jauge d'huile
- 5) Bouchon remplissage d'huile
- 6) Réservoir
- 7) Bouchon du réservoir
- 8) Robinet
- 9) Poulie lancement
- 10) Levier accélérateur
- 11) Magnète
- 12) Starter

- 1) Air cleaner
- 2) Rocker arms cover
- 3) Muffler
- 4) Dip stick
- 5) Oil filling plug
- 6) Fuel tank
- 7) Tank plug
- 8) Fuel tap
- 9) Starting pulley
- 10) Throttle lever
- 11) Magneto
- 12) Starter

- 1) Luftfilter
- 2) Kipphebeldeckel
- 3) Auspufftopf
- 4) Ölstand
- 5) Ölfülldeckel
- 6) Behälter
- 7) Tankdeckel
- 8) Hahn
- 9) Anwertscheibe
- 10) Gashebel
- 11) Magnet
- 12) Starter

- 1) Filtro aire
- 2) Tapa de los balancines
- 3) Silenciador
- 4) Varilla nivel
- 5) Tapon para llenar el aceite
- 6) Deposito
- 7) Tapon para el depósito
- 8) Grito
- 9) Polea arranque
- 10) Palanca acelerador
- 11) Magneto
- 12) Surtidor de arranque

MOTORE MOTEUR ENGINE MOTOR MOTOR	VT 88 W	VT 94 W	
Cilindri Cylindres Cylinders Zylinderzahl Cilindros	N	1	1
Corsa Course Stroke Hub Carrera	mm	79	79
Alesaggio Alésage Bore Bohrung Diametro	mm	88	94
Cilindrata Cylindrée Displacement Hubraum Cilindraje	cm <sup>3</sup>	480	548
COMBUSTIBILE COMBUSTIBLE FUEL KRAFTSTOFF COMBUSTIBLE	BENZINA ESSENCE PETROL BENZIN GASOLINA	BENZINA ESSENCE PETROL BENZIN GASOLINA	
Ciclo Otto 4 tempi Cycle Otto 4 temps Cycle 4 stroke Otto Arbeitsverfahren Otto-viertakt Ciclo Otto a 4 tiempos			

Adoperare olio avente le caratteristiche descritte in fig. 1, sia nel basamento che nel filtro aria.

*Employer, soit dans le carter moteur que dans le filtre à air, de l'huile ayant les caractéristiques indiquées à la fig. 1.*

Employ oil having the specifications described in illustr. 1, either in the crankcase or in the air filter.

*Man Verwendet sowohl im Kurbelgehäuse als auch im Luftfilter ein Öl, das die in Abb. 1, beschriebenen Eigenschaften besitzt.*

Usar aceite con las características mencionadas en la fig. 1, ya sea en el bloque motor como en el filtro aire.

**Agip DIESEL GAMMA**  
MIL - L - 2104B  
API - SC - CC

122	50	SAE 40
104	40	
86	30	SAE 30
68	20	
50	10	SAE 20W/20
32	0	
14	-10	SAE 10W
-4	-20	

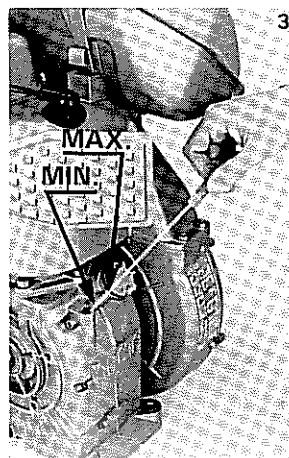
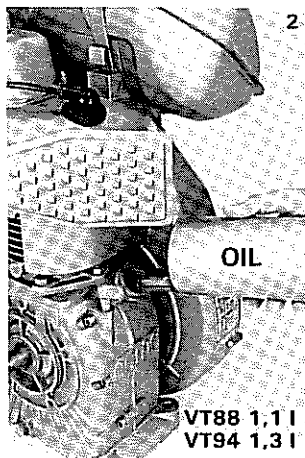

Riempire à livello  
Remplir jusqu' au niveau  
Fill up to level  
Bündig füllen  
Llenar hasta el nivel

COMBUSTIBLE · COMBUSTIBLE · FUEL · KRAFTSTOFF · COMBUSTIBLE

Usare benzina di buona qualità. Si consiglia il filtraggio (Fig. 5).

*Utiliser de l'essence de bonne qualité. Le filtrage est conseillé (Fig. 5).*

Use petrol of high quality. Filtering is recommended (illustr. 5).

*Man verwendet Benzin guter Qualität. Das Filtrieren wird beraten (Abb. 5).*

Usar gasolina de buena calidad. Se aconseja la filtración (Fig. 5).

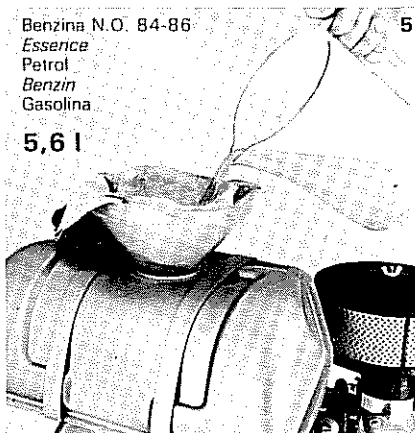

Fare una periodica pulizia al filtro benzina (Fig. 6).

*Nettoyer périodiquement le filtre combustible (Fig. 6).*

Clean periodically the petrol filter (Illustr. 6).

*Man reinigt periodisch den Benzinfilter (Abb. 6).*

Hágase una limpieza periódica del filtro de gasolina (Fig. 6).

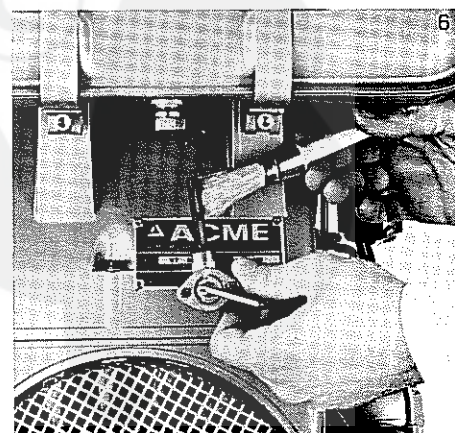

# AVVIAMENTO - DEMARRAGE - STARTING - ANLASSEN - ARRANQUE

Aprire il rubinetto e posizionare l'acceleratore a metà; a motore freddo chiudere lo starter (Fig. 7-8-9). Con basse temperature premere il pulsante "A" (Fig. 10).

Ouvrir le robinet et mettre l'accélérateur au milieu; à moteur froid fermer le starter (Fig. 7-8-9). A de basses températures appuyer sur le bouton "A" (Fig. 10).

Open the tank tap and to put the ignition in the middle; at cold engine to close the starter (Illustr. 7-8-9). With low temperature push "A" button (Illustr. 10).

Man öffnet den hahn und positioniert den Gashebel in die Mitte; wenn der Motor kalt ist, schliesst man den Starter (Abb. 7-8-9). Bei niedrigen Temperaturen drückt man den Knopf "A" (Abb. 10).

Abrir el grifo y poner el acelerador en su posición intermedia; si el motor está frío cerrar el surtidor de arranque (Fig. 7-8-9). Con bajas temperaturas apretar el pulsante "A" (Fig. 10).

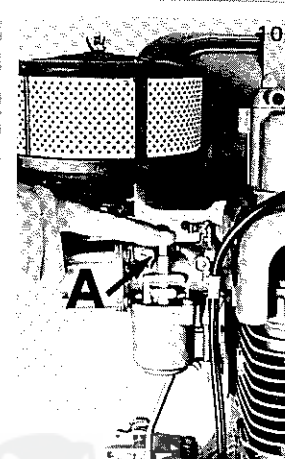
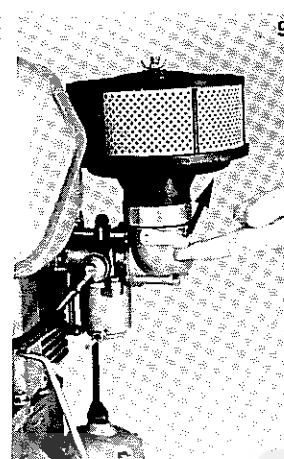
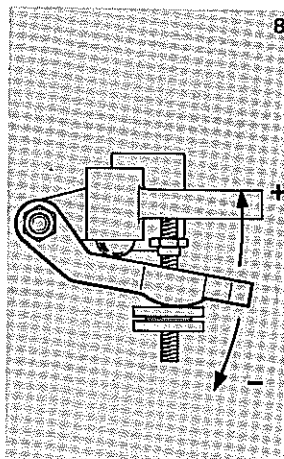
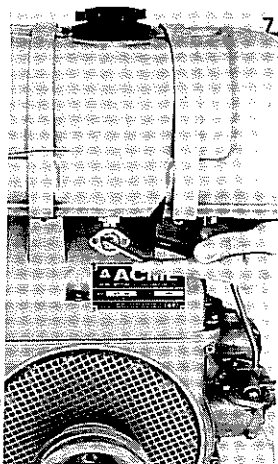

## A STRAPPO - A CORDELETTE - ROPE - SEILANLASSEN - A CUERDA

Avvolgere la funicella sulla puleggia e lassarla con decisione (Fig. 11). A motore avviato, aprire subito lo starter.

Enrouler la corde sur la poulie et tirer avec décision (Fig. 11). Lorsque le moteur est en marche, ouvrir tout de suite le starter.

Wind up the rope on the pulley and pull it resolutely (Illustr. 11). As soon as the engine has started, open the starter.

Man wickelt das Seil um die Riemenscheibe ein und zieht es mit Stärke (Abb. 11). Sobald der Motor läuft, öffnet man den Starter.

Enrollar la cuerda en la polea y lassarla con decisión (Fig. 11). Apenas el motor ha arrancado, abrir el surtidor de arranque.

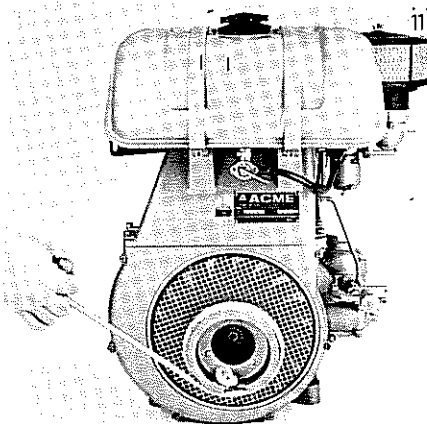

## ELETRICO - ELECTRIQUE - ELECTRIC - ELEKTRISCHES - ELECTRICO

Premere la leva alzavavola e girare la chiave su AVVIAMENTO (Fig. 12). A motore avviato aprire subito lo starter. Si consiglia una batteria da 50 Ah.

Appuyer sur le decompresseur manuel et tourner la clé sur le DEMARRAGE (Fig. 12). Lorsque le moteur est en marche, ouvrir tout de suite le starter. Il est conseillé une batterie de 50 Ah.

Push the valve lifter and turn the key on STARTING (Illustr. 12). As soon as the engine has started, open the starter. A battery of 50 Ah is recommended.

Man drückt den Ventilheber und dreht den Schlüssel auf ANLASSEN (Abb. 12). Sobald der Motor läuft, öffnet man den Starter. Man berat eine Batterie von 50 Ah.

Comprimir la palanca de la alzavavola y poner la llavecita en la posición ARRANQUE (Fig. 12). Apenas el motor ha arrancado, abrir el surtidor de arranque. Se aconseja una batería de 50 Ah.

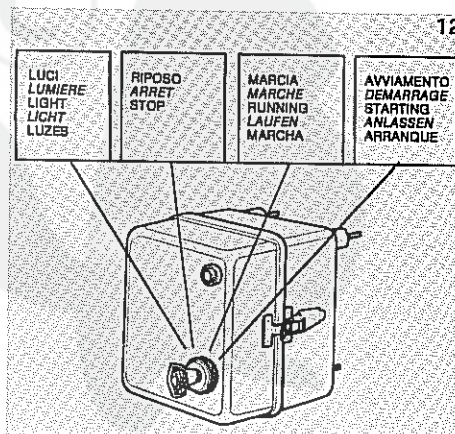

## ARRESTO - ARRET - STOP - ABSTELLEN - PARADA

Lasciare girare il motore al minimo per alcuni minuti, quindi premere il pulsante di massa o girare la chiave su STOP (Fig. 14-12).

*Laisser tourner le moteur au minimum pour quelques minutes, appuyer ensuite sur le bouton de masse ou tourner la clef sur ARRET (Fig. 14-12).*

Let the engine run at minimum speed for a few minutes, then push the earth push button or turn the key on STOP (Illustr. 14-12).

*Man lässt den Motor einige Minuten, dann drückt man den Stopknopf und dreht den Schlüssel auf ABSTELLUNG (Abb. 14-12).*

Se hace funcionar el motor al mínimo por algunos minutos, luego apretar el pulsador de masa o volver la llavecita a la posición STOP (Fig. 14-12).

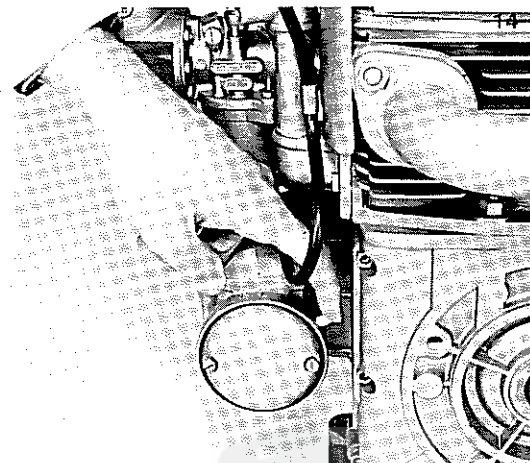
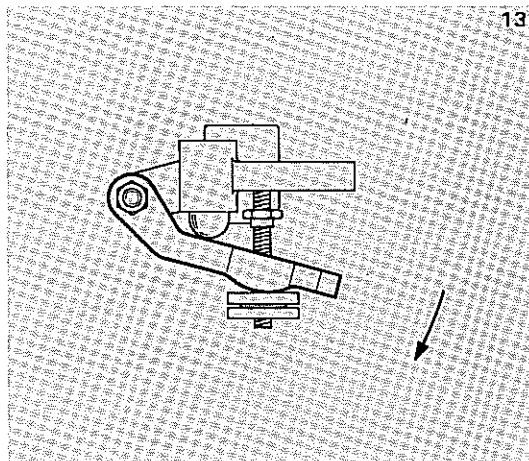

## NOTE - NOTES - NOTES - ERKLÄRUNGEN - NOTAS

Riscaldare il motore prima di applicare il carico. Aumentare gradualmente i giri. Dopo le prime 25 ore di funzionamento, sostituire l'olio. Non far funzionare per lungo tempo il motore al minimo. Attenervi alle istruzioni è nel Vostro interesse. Prolungherete la durata del Vostro motore.

*Chauffer le moteur avant de le charger. Augmenter graduellement la vitesse. Après les premières 25 heures de fonctionnement remplacer l'huile. Le moteur ne doit pas fonctionner longtemps au minimum. Dans votre intérêt il est conseillé s'en tenir aux instructions. Vous prolongerez la vie de votre moteur.*

Warm-up the engine before loading. Bring it gradually to operating speed. After the first 25 hours of running change the oil. Do not let the engine idle for a long time. It is your interest to follow the instructions. You will prolong the life of your engine.

*Motor vor seiner Belastung warnlaufen lassen. Stufenweise bis zur Vollastdrehzahl bringen. Nach den ersten 25 Stunden Lauf das Öl wechseln. Man soll den Motor nicht lang leerlaufen lassen. Es ist Ihr Interesse, den Anweisungen zu folgen. Sie werden die Dauer Ihres Motors verlängern.*

Calentar el motor antes de aplicar la carga. Aumentar gradualmente la velocidad. Después de las primeras 25 horas de funcionamiento cambiar el aceite. No se haga funcionar el motor por mucho tiempo al mínimo. Seguir las instrucciones está en su interés. Ya que la vida de sumotor será prolongada.

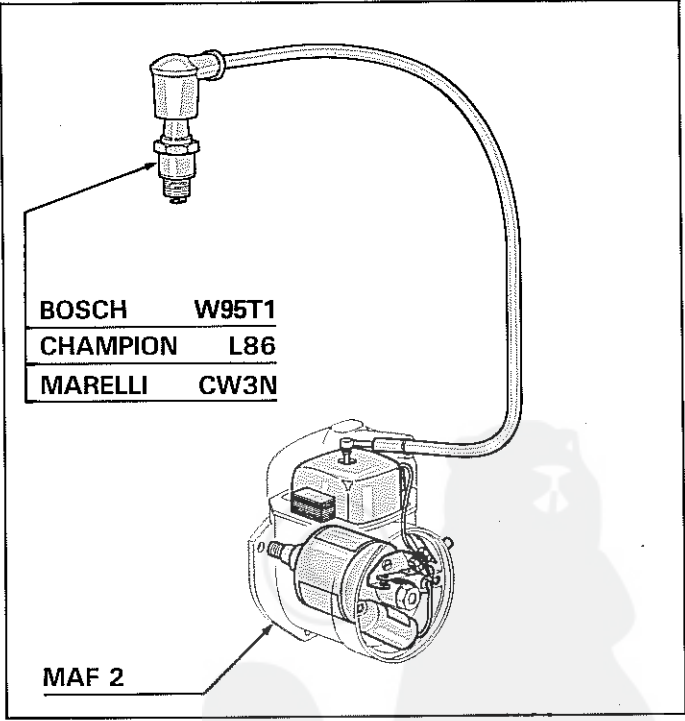
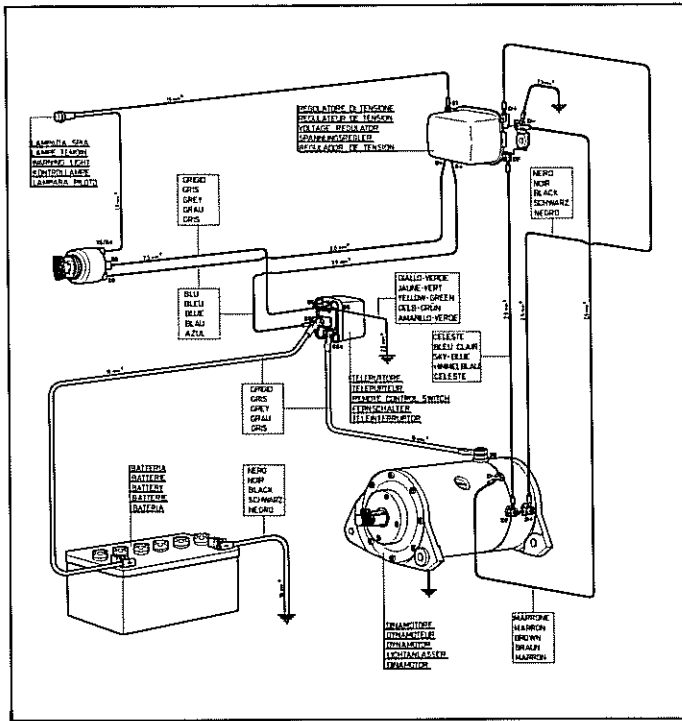

In moto: chiave su MARCIA. Da fermo, chiave su RIPOSO. Si consiglia una periodica manutenzione del dinamotore.  
 En fonction: clef sur MARCHE. A moteur arrêté: clef sur ARRET. Il est conseillé faire une maintenance périodique du dynamoteur.  
 Running: keyswitch on RUNNING. Stopping: keyswitch on STOP. A periodic maintenance of the dynamotor is recommended.  
 Laufend: Schlüssel auf GANG. Still: Schlüssel auf RUHE. Man berät eine periodische Warnung des Dynamotors.  
 Puesta en marcha: llavecita en la posición MARCHA. Parada: llavecita en la posición STOP. Se aconseja una periódica manutención de dinamotor.

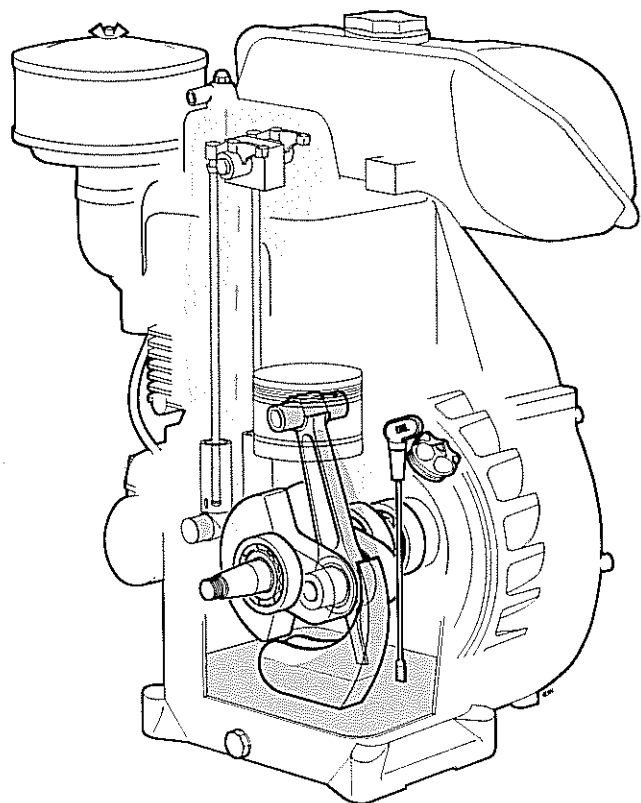

**CIRCUITO LUBRIFICAZIONE**  
**CIRCUIT DE GRAISSAGE**  
**LUBRICATING SYSTEM**  
**SCHMIERUNGSSYSTEM**  
**CIRCUITO LUBRIFICACION**

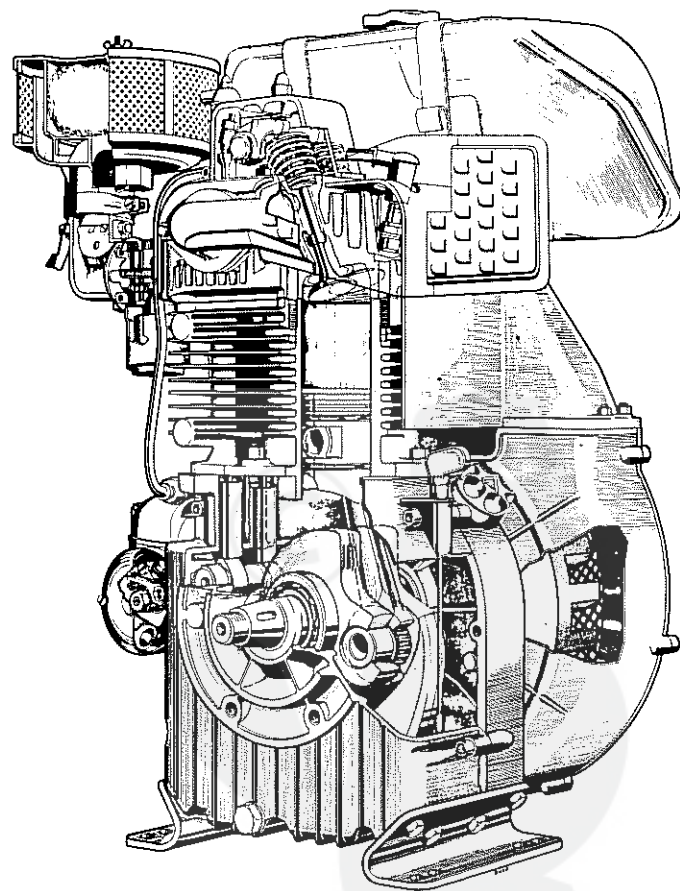

OGNI  
CHAQUE  
EVERY  
JEDE  
CADA



8 H

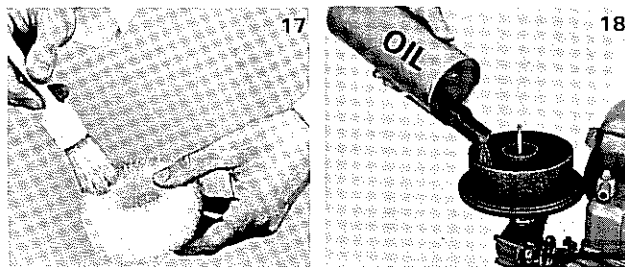
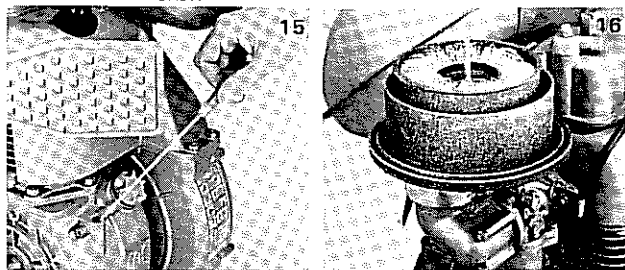

Controllare il livello dell'olio nel carter. (Fig. 15). Pulire il filtro aria e sostituirvi l'olio (Fig. 16-17-18).

*Contrôler le niveau de l'huile dans le carter (Fig. 15). Nettoyer le filtre à air et y remplacer l'huile (Fig. 16-17-18).*

Check the oil level in the crankcase (Illustr. 15). Clean the air filter and change the oil (Illustr. 16-17-18).

*Man kontrolliert den Ölstand im Kurbelgehäuse (Abb. 15). Man reinigt den Ölfilter und ersetzt das Öl (Abb. 16-17-18).*

Controlar el nivel del aceite en el bloque motor (Fig. 15). Limpiar el filtro del aire y reemplazar el aceite del mismo (Fig. 16-17-18).

OGNI  
CHAQUE  
EVERY  
JEDE  
CADA



100 H

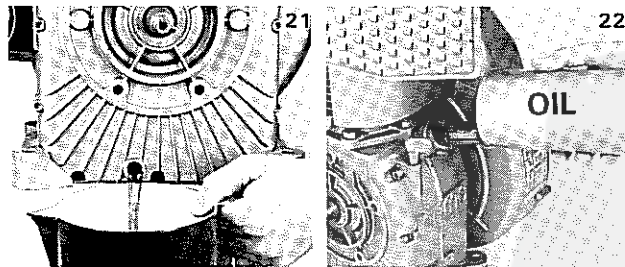
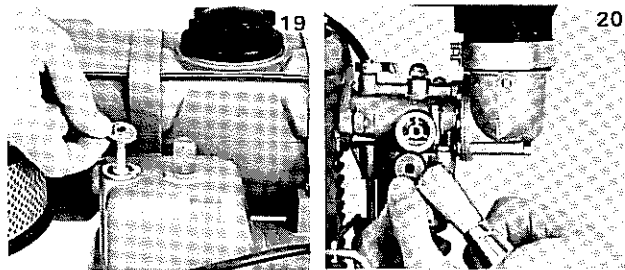

Pulire la valvolina sfiato olio (Fig. 19) e il filtro benzina (Fig. 20). Sostituire completamente l'olio nel carter (Fig. 21-22).

*Nettoyer la soupape reniflard (Fig. 19) et le filtre combustible (Fig. 20). Remplacer complètement l'huile dans le carter (Fig. 21-22).*

Clean the oil breather (Illustr. 19) and the fuel filter (Illustr. 20). Change completely the oil in the crankcase (Illustr. 21-22).

*Man reinigt den Öelentlüfter (Abb. 19) und den Benzinflter (Abb. 20). Man ersetzt das Öl im Kurbelgehäuse völlig (Abb. 21-22).*

Limpiar la valvulita respiradero de aceite (Fig. 19) y el filtro de gasolina (Fig. 20). Cambiar completamente el aceite en el bloque motor (Fig. 21-22).

OGNI  
CHAQUE  
EVERY  
JEDE  
CADA

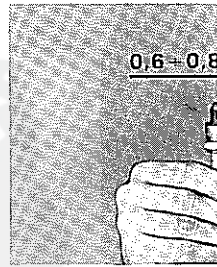
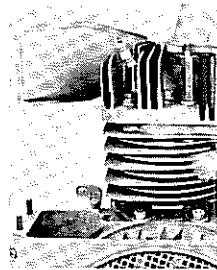

Pulire le alette del sta e controllare la 24).

*Nettoyer les alette la culasse et cor (Fig. 23-24).*

Clean the cylinder fins and check the 24).

*Man reinigt die A ders und des Kopl die Zündkerze (Ab*

Limpiar las aletas y culata y controlar 24).



300 H



23

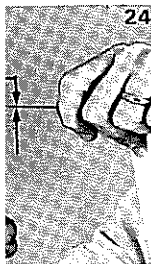

24

OGNI  
CHAQUE  
EVERY  
JEDE  
CADA



1000 H

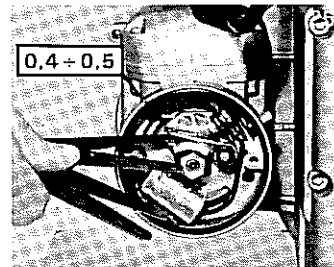

0,4 ÷ 0,5

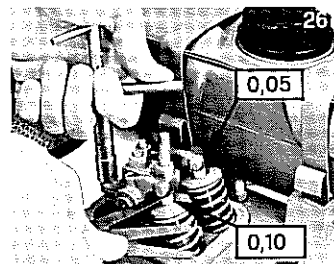

26

0,05

0,10

Pulire i contatti, controllare il gioco valvole (Fig. 25-26).

*Nettoyer les contacts et contrôler le jeu des soupapes (Fig. 25-26).*

Clean the breather points, check the valves clearance (Illustr. 25-26).

*Man reinigt die Kontakte, und überprüft Ventilspiel (Abb. 25-26).*

Limpiar los platinos y controlar el juego de las válvulas (Fig. 25-26).

ndro, della te-  
idela (Fig. 23-

u cylindre, de  
er la bougie

ylinder head  
park plug (Il-

en des Zyllin-  
und überprüft

cilindro, de la  
ujja (Fig. 23-

OGNI  
CHAQUE  
EVERY  
JEDE  
CADA



2000 H

**REVISIONE  
REVISION  
OVERHAUL  
OBERHOLUNG  
REVISION**

Comprende: controllo cilindro, fasce elastiche, molle, bobina accensione, carburatore e smerigliatura sedi valvole.

*Comprend: le contrôle du cylindre, des segments, des ressorts, de la bobine allumage, du carburateur et le rodage des sièges soupapes.*

Includes: control of cylinder, piston rings, springs, control of ignition coil, carburettor and grinding of valve seats.

*Schliesst die Kontrolle des Zylinders, der Kolbenringe, der Federn, die Kontrolle der Zündspule, des Vergasers und das Einschleifen der Ventilsitze ein.*

Comprende: el control del cilindro, de los segmentos, de los resortes, de la bobina para el encendido, del carburador y el esmerillado de los asientos de la válvulas.

IMMAGAZZINAGGIO  
STOCKAGE  
STORING  
EINLAGERUNG  
ALMACENAMIENTO

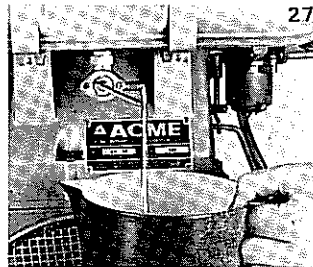

27

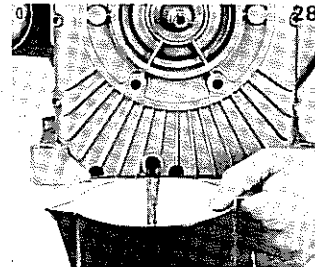

28

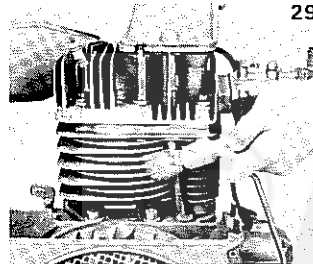

29

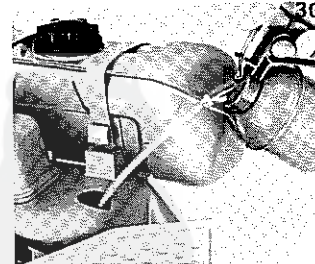

30

Togliere tutto il carburante, l'olio dal carter, pulire le alette e mettere alcune gocce d'olio nel foro della candela (Fig. 27-28-29-30).

*Enlever tout le combustible, l'huile du carter, nettoyer les ailettes et mettre quelques gouttes d'huile dans le trou de la bougie (Fig. 27-28-29-30).*

Remove all the fuel and empty the crankcase from the oil, clean the fins and put some drops of oil on the spark plug hole (Illustr. 27-28-29-30).

*Man nimmt den Kraftstoff völlig heraus, entleert das Kurbelgehäuse vom Öl, reinigt die Rippen und giesst einige Tropfen Öl auf die Zündkerzenöffnung (Abb. 27-28-29-30).*

Sacar todo el carburante, el aceite del bloque motor, limpiar las aletas y poner algunas gotas de aceite en el ojo de la bujia (Fig. 27-28-29-30).



BASAMENTO

CARTER MOTEUR

CRANKCASE

KURBELGEHÄUSE

BANCADA

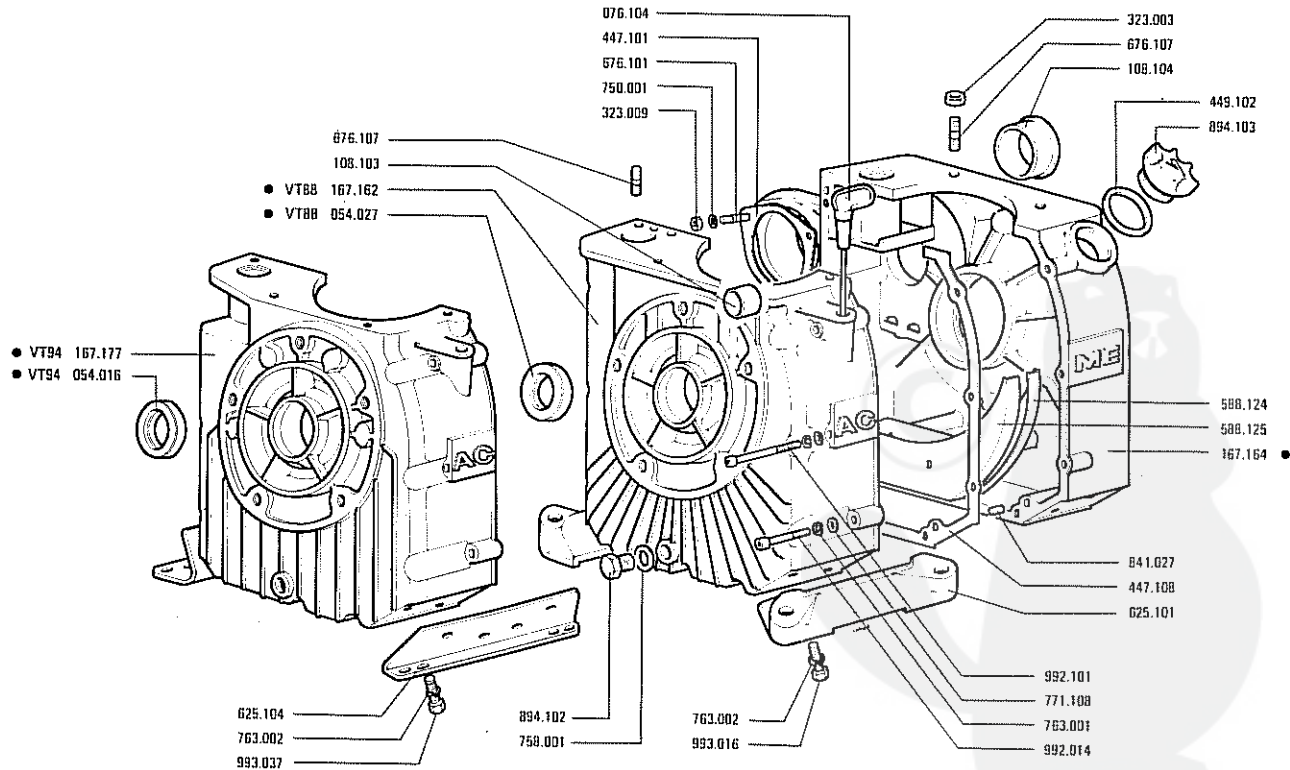

● Particolare appartenente ad un gruppo completo – Pièce composant un groupe complet – Part included in a complete groupe – Teile einer kompl. Gruppe – Pieza de un grupo completo



MANOVELLISMO

VILEBREQUIN,  
BIELLE  
ET PISTON

CRANKSHAFT,  
CONNECTING ROD  
AND PISTON

KURBELWELLE,  
PLEUELSTANGE  
UND KOLBEN

CIGUENAL,  
BIELA  
Y PISTON

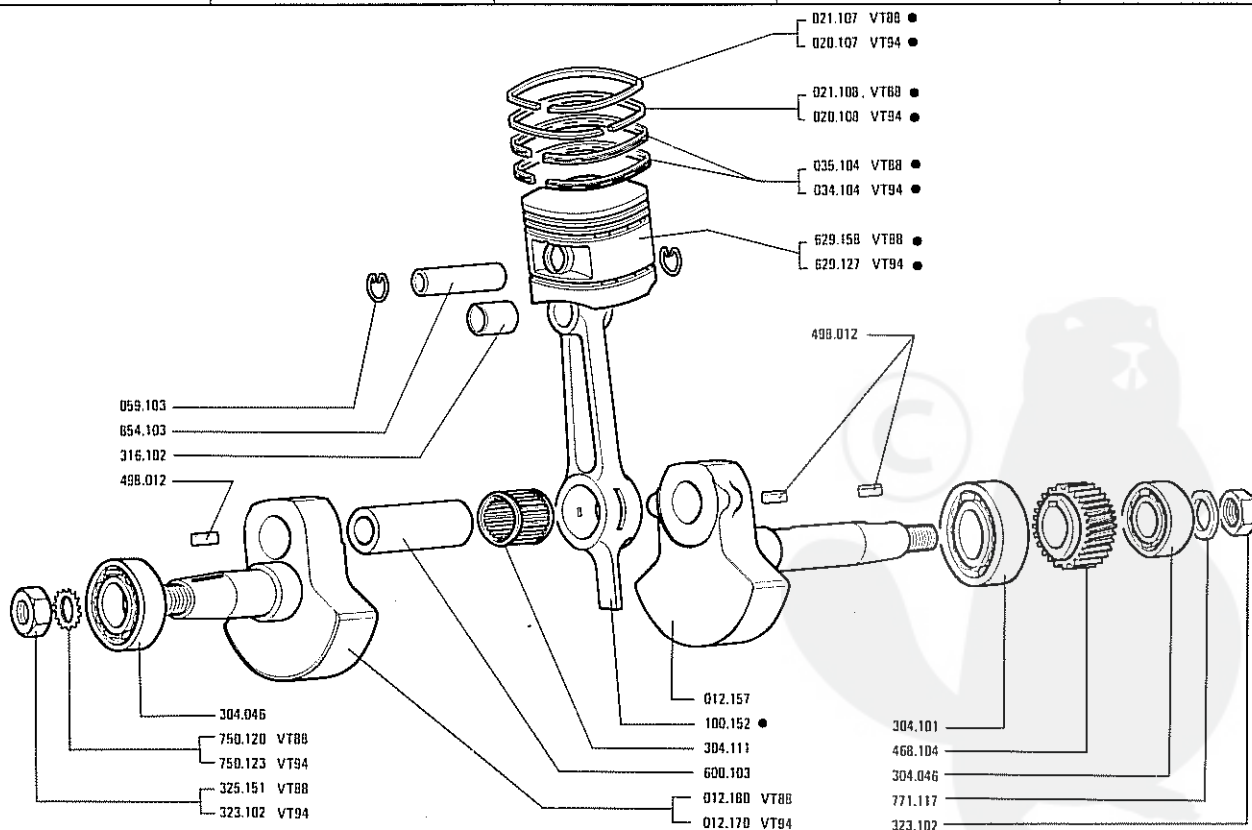

● Particolare appartenente ad un gruppo completo – Pièce composant un groupe complet – Part included in a complete groupe – Teile einer kompl. Gruppe – Pieza de un grupo completo



TESTA CILINDRO

CULASSE  
ET CYLINDRE

CYLINDER HEAD  
AND CYLINDER

ZYLINDERKOPF  
UND ZYLINDER

CULATA  
Y CILINDRO

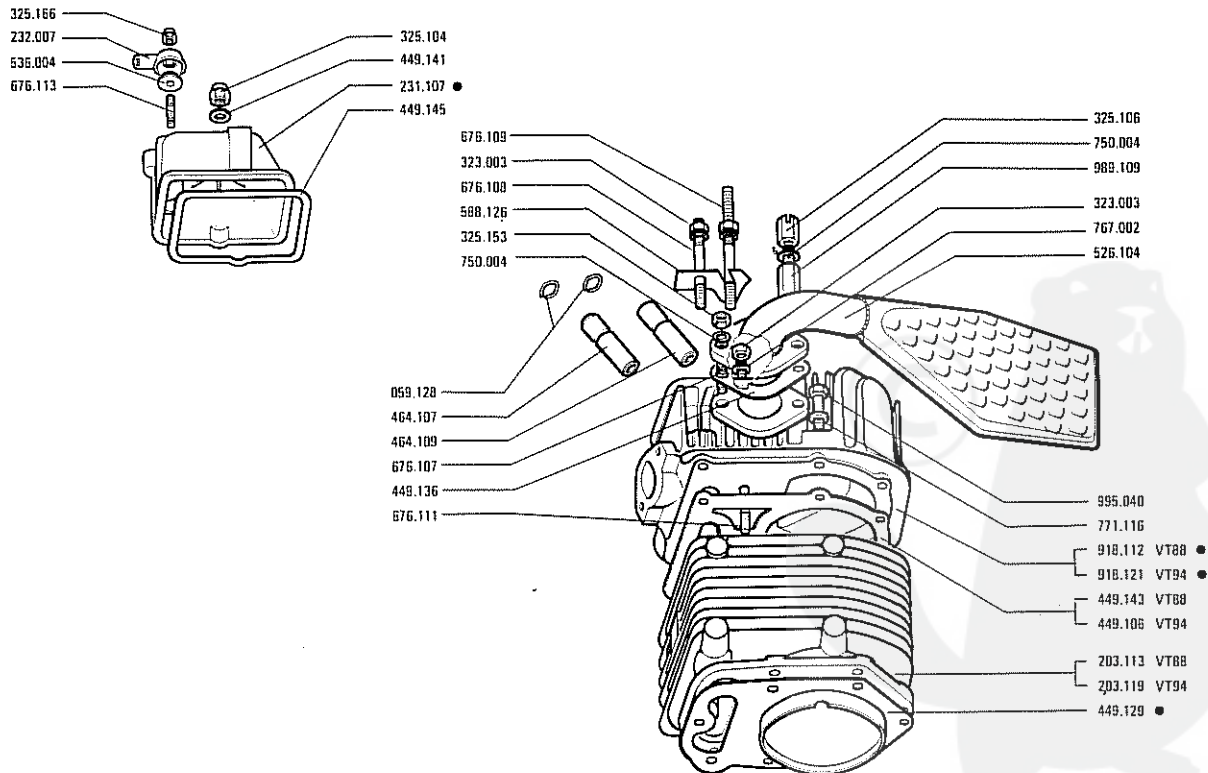

● Particolare appartenente ad un gruppo completo - Pièce composant un groupe complet - Part included in a complete groupe - Teile einer kompl. Gruppe - Pieza de un grupo completo



DISTRIBUZIONE.  
REGOLATORE  
DI GIRI

DISTRIBUTION.  
REGULATEUR  
DE TOURS

DISTRIBUTION.  
SPEED  
GOVERNOR

NOCKENSTEU-  
RUNG  
DREHZAHLEGLER

DISTRIBUCION  
REGULADOR  
DE VELOCIDAD

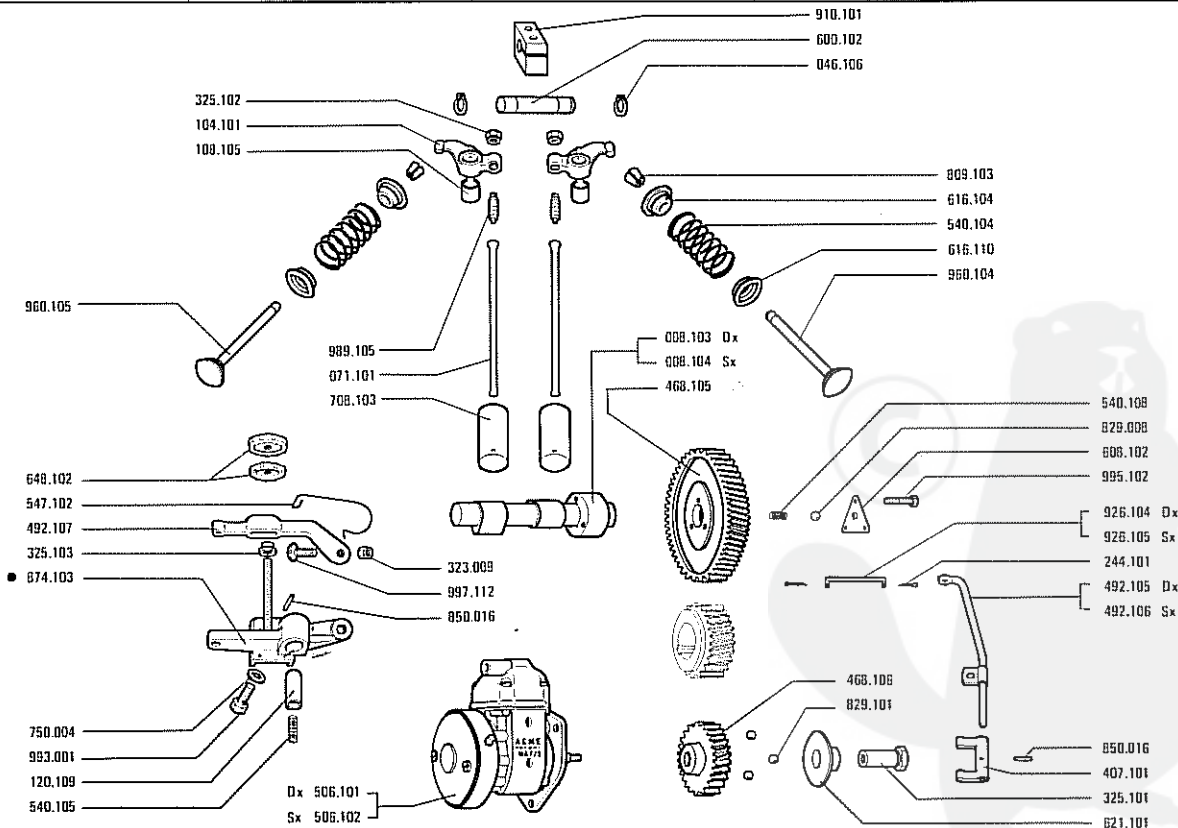

● Particolare appartenente ad un gruppo completo - Pièce composant un groupe complet - Part included in a complete group - Teile einer kompl. Gruppe - Pieza de un grupo completo



RAFFREDDAMENTO

REFROIDISSEMENT

COOLING SYSTEM

KÜHLUNG

ENFRIAMIENTO

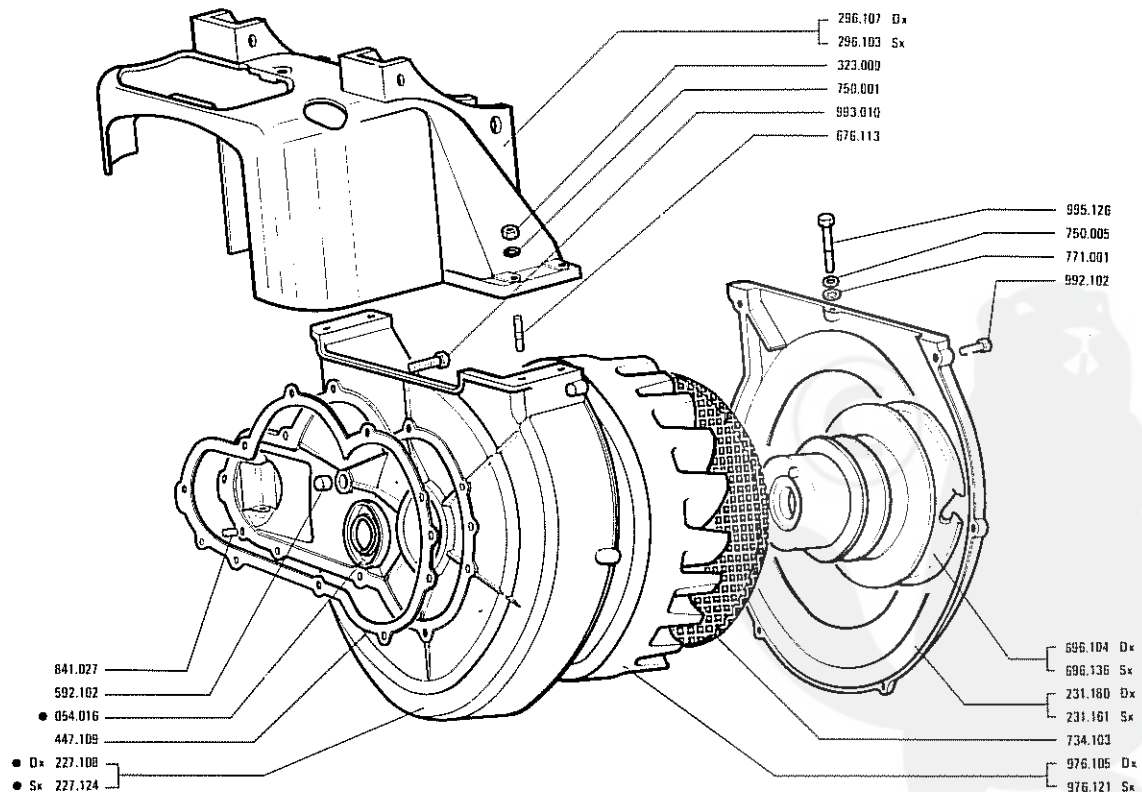

● Particolare appartenente ad un gruppo completo – Pièce composant un groupe complet – Part included in a complete groupe – Teile einer kompl. Gruppe – Pieza de un grupo completo



ALIMENTAZIONE  
A BENZINA.  
FILTRO ARIA

ALIMENTATION  
A ESSENCE.  
FILTRE A AIR

PETROL  
FEEDING.  
AIR CLEANER

BENZIN-  
SPEISUNG.  
LUFTFILTER

ALIMENTACION  
CON GASOLINA.  
FILTRO AIRE

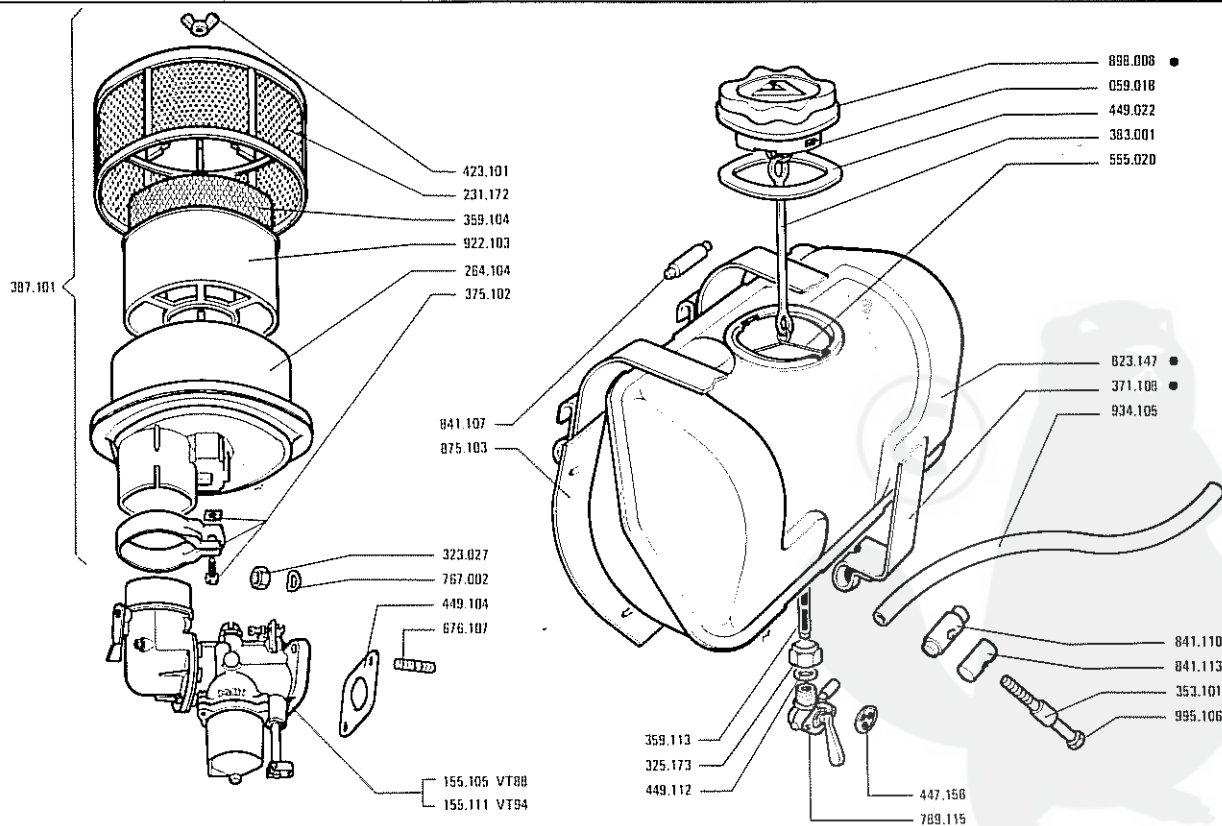

● Particolare appartenente ad un gruppo completo - Pièce composant un groupe complet - Part included in a complete groupe - Teile einer kompl. Gruppe - Pieza de un grupo completo



CARBURATORE

CARBURATEUR

CARBURETTOR

VERGASER

CARBURADOR

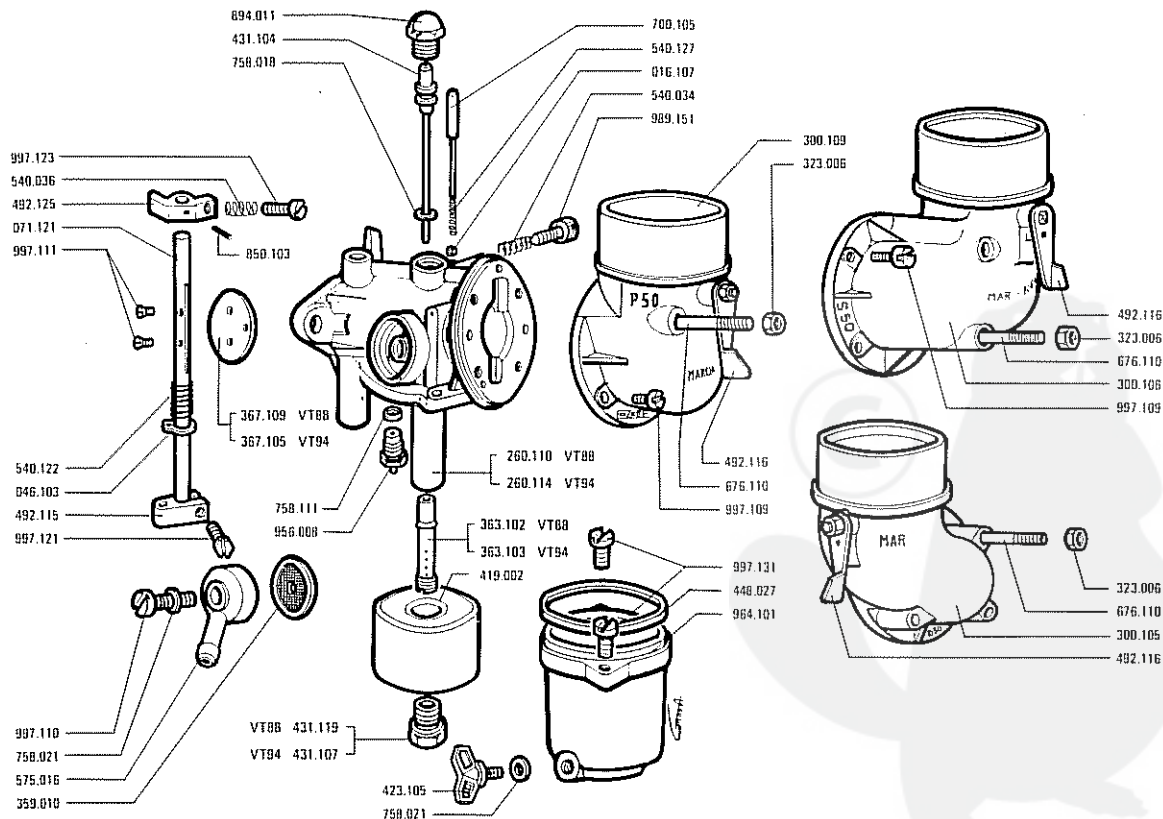

● Particolare appartenente ad un gruppo completo – Pièce composant un groupe complet – Part included in a complete group – Teile einer kompl. Gruppe – Pieza de un grupo completo





MAGNETE

MAGNETO

MAGNETO

MAGNET

MAGNETO

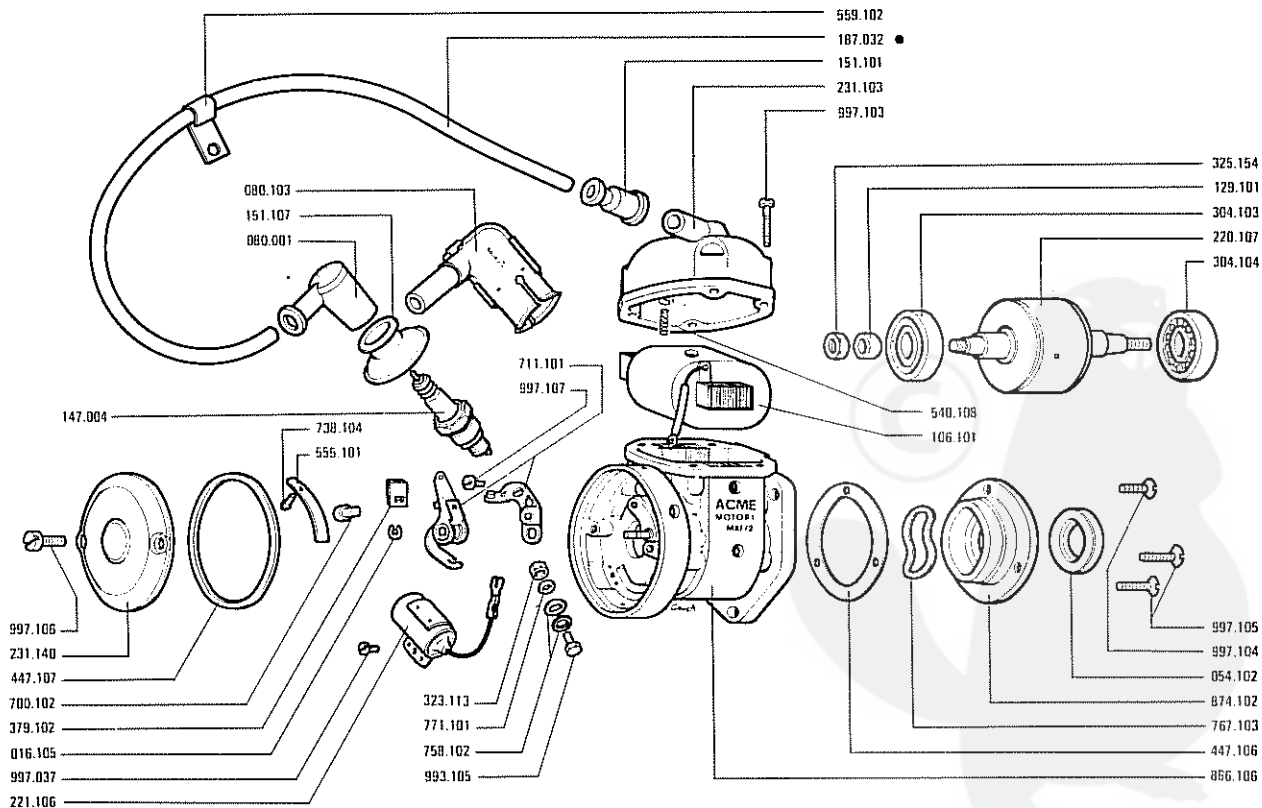

● Particolare appartenente ad un gruppo completo – Pièce composant un groupe complet – Part included in a complete groupe – Teile einer kompl. Gruppe – Pieza de un grupo completo



AVVIAMENTO  
ELETTRICO  
DINAMOTORE

DEMARRAGE  
ELECTRIQUE  
AVEC DYNAMOTEUR

ELECTRIC  
STARTING  
WITH DYNAMOTOR

ELEKTRISCHE  
ANLASSUNG MIT  
LICHTANLASSER

ARRANQUE  
ELECTRICO  
DINAMOTOR

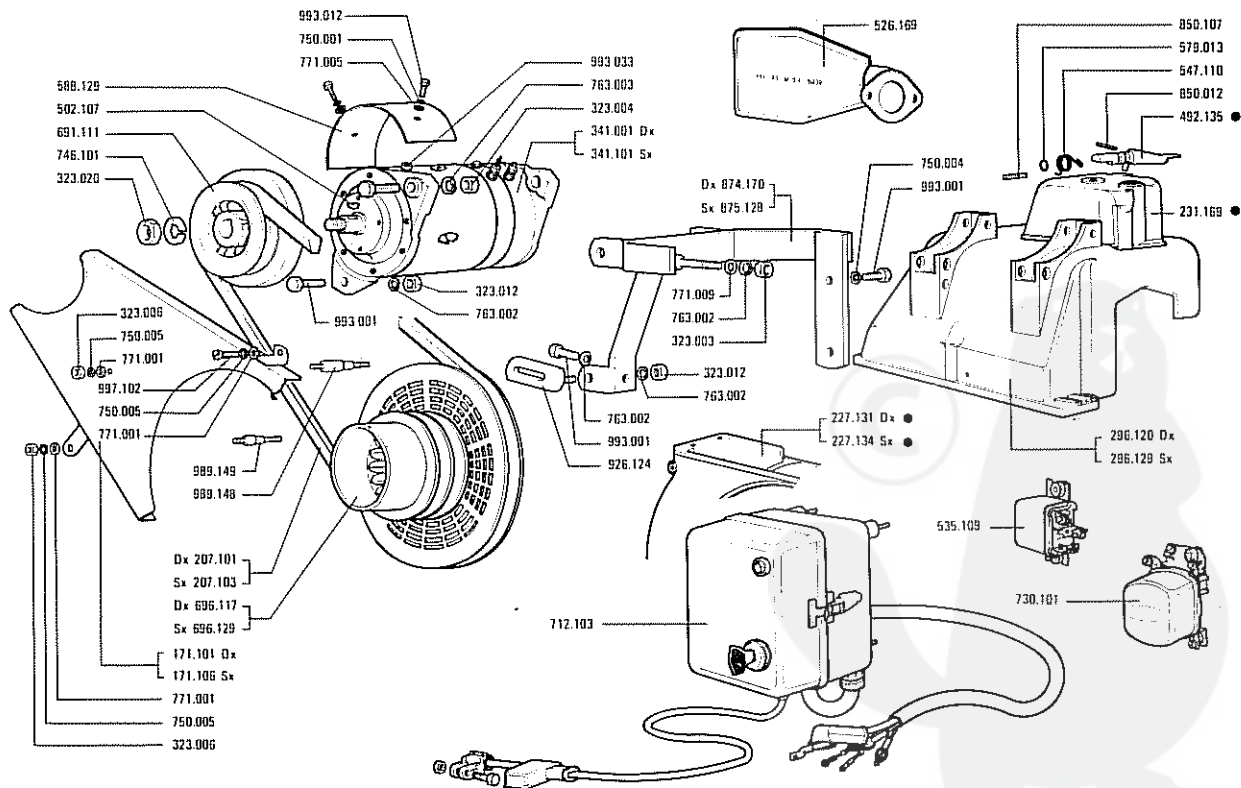

● Particolare appartenente ad un gruppo completo - Pièce composant un groupe complet - Part included in a complete groupe - Teile einer kompl. Gruppe - Pieza de un grupo completo

## CONDIZIONI DI GARANZIA

L'A.C.M.E. MOTORI S.p.A. garantisce i motori di sua produzione per la durata di 12 mesi dalla data di acquisto.

La durata della garanzia viene ridotta a 6 mesi per i motori che lavorano regolarmente più di 6 ore al giorno continuative.

In tale periodo si impegna solamente a sostituire o riparare quelle parti che a suo giudizio presentino vizi di fabbricazione o di materiale, con esclusione di risoluzioni di contratti e di ogni altra responsabilità ed obbligazione, danni, perdite dirette ed indirette derivanti dall'uso o mancato uso dei motori.

La garanzia non è riconosciuta se l'avaria è dovuta a: motori non usati in accordo con le istruzioni dell'ACME; manomissione dei sigilli apposti dall'ACME; motori smontati, riparati o modificati da officine non autorizzate dall'ACME; mancata manutenzione; uso di carburanti o lubrificanti inadatti; normale usura.

Per le parti ed accessori non prodotti dall'ACME, si applicano le garanzie date dai singoli fabbricanti.

La presente garanzia annulla e sostituisce ogni altra garanzia esplicita od implicita ed è modificabile solo per iscritto.

## WARRANTY CLAUSES

All engines manufactured by the A.C.M.E. MOTORI S.p.A. are warranted for 12 months, beginning from the date of purchase.

The warranty period is reduced down to 6 months in the case of engines which work daily more than 6 hours continuously.

In such warranty period, the after-sale service is restricted only to replacing or repairing those components which, in the indisputable opinion of ACME engineers, would show machining defects or material flaws, with exclusion of invalidation of contracts, or on any other responsibilities, damages, direct or indirect losses caused by the use or non-use of the engines.

No warranty shall be acknowledged when the failure is caused by the non-compliance of ACME directions for the use and operation of the engines; tampering of seals set by ACME; engines disassembled, repaired or modified in shops not authorized by ACME; default of maintenance; use of improper fuels or lubricants; normal wear.

The warranties guaranteed by the related manufacturers hold in the case of spares and accessories not produced by the ACME.

Any other express or implied warranty is cancelled and substituted by this warranty, which clauses can be modified by writing only.

## CLAUSES DE GARANTIE

La A.C.M.E. MOTORI S.p.A. garantit les moteurs de sa propre construction pour une durée de 12 mois à partir de la date de leur achat.

Pour ce qui concerne les moteurs destinés à travailler régulièrement pour plus de 6 heures par jour continuellement, la garantie est donnée pour une durée de 6 mois à partir de la date d'achat.

Pendant les périodes de garantie précitées, ACME s'engage uniquement à remplacer, ou réparer les pièces qui sont jugées, à l'avis de ACME, comme présentant des vices de construction ou de matière première, avec exclusion de résiliation de contrats et de toute autre responsabilité, obligation, dommages, pertes directes ou indirectes dérivant de l'utilisation ou non utilisation des moteurs considérés.

La garantie n'est pas reconnue par ACME si le dommage est dû aux causes suivantes: moteurs non utilisés selon les instructions données par ACME; manipulation indue des sceaux apposés par ACME; moteurs démontés, réparés ou modifiés par des ateliers ou usines non autorisés par ACME; défauts d'entretien; emploi de carburants ou de lubrifiants non appropriés; usure normale.

Pour les pièces et accessoires qui ne sont pas de construction ACME, on appliquera les garanties respectives données individuellement par les constructeurs de ces pièces et accessoires.

La présente garantie annule et remplace toute autre garantie explicite ou implicite et elle peut être modifiée uniquement par écrit.

## GEWÄHRLEISTUNG

A.C.M.E. MOTORI S.p.A. leistet Gewähr für eine dem jeweiligen Stand der Technik des Motortyps entsprechende Fehlerfreiheit für 12 Monate.

Für Motoren, die regelmäßig täglich mehr als 6 Stunden im Dauereinsatz betrieben werden, beträgt die Gewährleistungszeit 6 Monate.

Während der Gewährleistungszeit verpflichtet sich ACME MOTORI dazu, Teile zu ersetzen oder zu reparieren, die Herstellungs- oder Materialfehler aufweisen. Jede weitere, über die gesetzlichen Bestimmungen hinausgehende Haftung wird abgelehnt.

Voraussetzung für obige Gewährleistung ist, daß die Motoren entsprechend der Bedienungsanleitung der Firma ACME behandelt werden, daß die dort vorgeschriebenen Wartungs- und Pflegearbeiten pünktlich ausgeführt und daß die vorgeschriebenen Kraftstoffe und Schmiermittel verwandt werden. Die Garantie erlischt, wenn innerhalb der Gewährleistungszeit Reparaturen durch nicht autorisierte Werkstätten durchgeführt werden. Normaler Verschleiß ist von der Gewährleistung ebenfalls ausgeschlossen.

Für Zubehör, das nicht von der Firma ACME hergestellt wird, gelten die Gewährleistungsbestimmungen der Zubehöhersteller.

Diese Gewährleistungsbestimmungen annullieren und ersetzen alle vorher von der Firma ACME herausgegebenen Bestimmungen dieser Art in allen Teilen. Sie können nur schriftlich abgeändert werden.



ACME MOTORI S.p.A.  
31049 VALDOBBIADENE  
(Treviso) Italy - Telephone (0423) 73245  
P.O. Box n. 38 - Telex 410573 ACME I  
Telefax (0423) 73623

FILIALI, SOCIETÀ COLLEGATE E SOCIETÀ LICENZIATARIE  
BRANCHES, ASSOCIATED COMPANIES AND LICENCEE COMPANIES  
FILIALES, SOCIÉTÉS ASSOCIÉES ET SOCIÉTÉS CONCESSIONNAIRES DE LICENCE  
FILIALEN, SCHWESTERFIRMEN UND LIZENZNEHMER

#### ACME NORTH AMERICA CORPORATION

5209 West 73rd street  
MINNEAPOLIS (MINN.) 55435

#### F.I.M. Spa

Viale Italia 32  
31040 SEGUSINO (TV)

#### LICENSINTORG

Minskaja street 11  
MOSCOW 121108 (U.S.S.R.)

#### ACME FRANCE

9, Rt. De La Porte de Fourqueux  
78112 - FOURQUEUX (France)

#### TOMOS - TOVARNA MOTORNIH VOZIL

Smarska 4  
66001 KOPER (Yugoslavija)

#### MOTOREPS C.A.

Avenida Pedro Leon Torres con Calle 52  
BARQUISIMETO (Venezuela)

#### USA RICAMBI ORIGINALI ACME

Nel ringraziarti per averci riservato la tua preferenza, ci permettiamo di ricordarti che è nel tuo interesse acquistare sempre e unicamente ricambi e componenti originali ACME:

- per ottenere il ripristino della completa funzionalità del motore
- per preservare la sua affidabilità e durata
- per essere sicuro di beneficiare degli aggiornamenti tecnici intervenuti dal momento dell'acquisto
- per mantenere efficace alle condizioni di garanzia (e perché ciò che costa meno non vale di più...).

Come vedi, hai molte buone ragioni per seguire il nostro consiglio. Richiedi sempre e pretendi RICAMBI ORIGINALI ACME.

#### UTILISEZ DES PIECES DE RECHANGE ORIGINALES ACME

Merci de votre préférence. Nous nous permettons de vous rappeler qu'il est dans votre intérêt d'acheter toujours et seulement des pièces de rechange originales ACME:

- pour rétablir la fonction complète du moteur
- pour préserver sa durée et sa fiabilité
- pour être sûrs de bénéficier des mises à jour techniques de votre achat
- pour maintenir toujours valables les conditions de garantie (car ce qui coûte moins ne vaut pas plus...).

Comme vous voyez, il y a de bonnes raisons pour suivre nos conseils. Demandez toujours et exigez les PIÈCES DE RECHANGE ORIGINALES ACME.

#### USE ACME ORIGINAL SPARE PARTS

Thank you for your choice. We take the liberty of reminding you that it is your own interest to buy only ACME original parts:

- to obtain again the complete functionality of your engine
- to preserve its reliability and life
- to be sure that you will be enjoying the technical updates since your first purchase
- to keep the efficacy unchanged under guarantee conditions (and because what costs less isn't more valuable...).

As you can see, there are many reasons to take our advice. Always demand ACME ORIGINAL SPARE PARTS.

#### BENUTZEN SIE DIE ORIGINALLEN ERSATZTEILE ACME

Indem wir Ihnen für die Aufmerksamkeit danken, die Sie unseren Waren geschenkt haben, erlauben wir uns, Ihnen zu erinnern, dass es in Ihrem Interesse liegt, Ersatzteile und Bestandteile ACME immer und allein zu beziehen:

- um die komplette Leistungsfähigkeit des Motors wieder zu schaffen
- um die originale Lebensdauer und Zuverlässigkeit des Motors zu schützen
- um aus den technischen Verbesserungen Nutzen zu ziehen, die nach dem Ankauf vorgenommen worden sind
- um die Garantie noch in Kraft zu behalten (nicht immer was weniger kostet, mehr Wert hat...).

Wie Sie sehen, gibt es viele gute Gründe, um unseren Empfehlungen zu folgen. Verlangen Sie immer ORIGINALLE ERSATZTEILE ACME.



ACME SPA · 31049 VALDOBBIADENE TREVISO ITALY · VIA ERIZZO 43 · TELEFONO 0423 73245 · TELEX 410573 ACME I

*Particolari per motore standard. Per applicazioni speciali consultare il Catalogo presso i Centri Assistenza e Ricambi. Descrizioni e illustrazioni non impegnative.*

*Pièces pour des moteurs standard. Pour les adaptations consulter le Catalogue auprès des Agents Service. Descriptions et illustrations peuvent être modifiées.*

*Parts for standard engine. For special applications see Master Catalog at Service Centers. Descriptions and characteristics subject to modifications.*

*Teile für Standard-Motoren. Für Sonderanfertigungen siehe Ersatzteilkatalog bei Service-Workstätten. Änderungen vorbehalten*

*Repuestos motores standard. Para aplicaciones especiales véase Catalogo en las estaciones Servicio. Instrucciones e ilustraciones pueden ser modificadas.*