

42 INCH CUT MOWER MULCHER KIT

Number MK420B

INSTALLATION INSTRUCTIONS

Kit Contains:

- | | |
|-------------------|------------------|
| (1) Mulcher Plate | (2) Lock Washers |
| (2) Mulcher Blade | (2) Flat Washers |
| (2) Latch Hooks | (2) Weld Nuts |
| (2) Screws | |

REPLACE MOWER BLADES (See Fig. 1)

- Raise mower to highest position to allow access to blades.
- Remove blade bolt securing blades.
- Install mulcher blades with trailing edge up towards deck as shown.

IMPORTANT: TO ENSURE PROPER ASSEMBLY, CENTER HOLE IN BLADE MUST ALIGN WITH STAR ON MANDREL ASSEMBLY.

Three (3) bolt mandrels -

- Reassemble blade bolt, lock washer and flat washer, previously removed, in exact order as shown.
- Tighten bolt securely (30-35 Ft. Lbs. torque).

Four (4) bolt mandrels -

- Reassemble blade bolt.
- Tighten bolt securely (45-55 Ft. Lbs. torque).

IMPORTANT: SPECIAL BLADE BOLT IS HEAT TREATED.

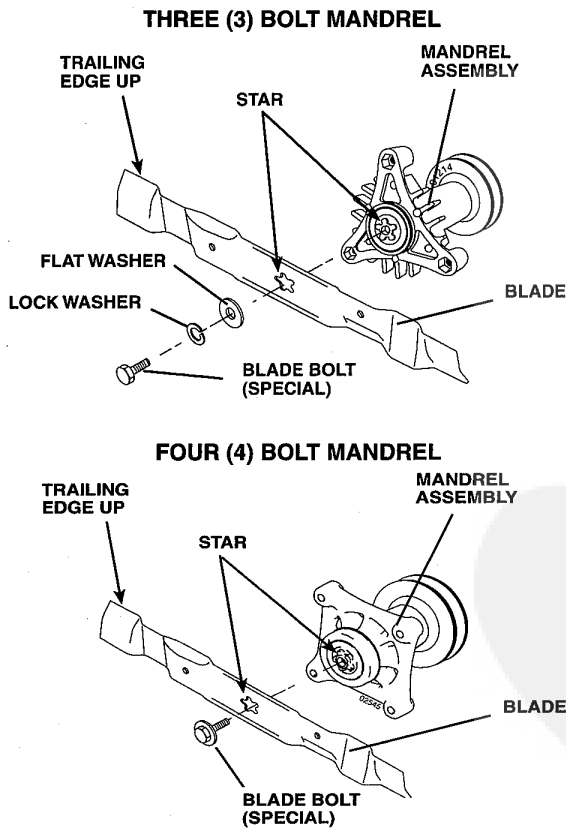

FIG. 1

INSTALL MULCHER PLATE

(See Figs. 2, 3 & 4)

- Install two latch hooks to mulcher plate using screw, washer, lock washer, and weld nut as shown.

NOTE: Pre-assemble weld nut to latch hook by inserting weld nut from the top with hook pointing down.

- Tighten hardware securely.

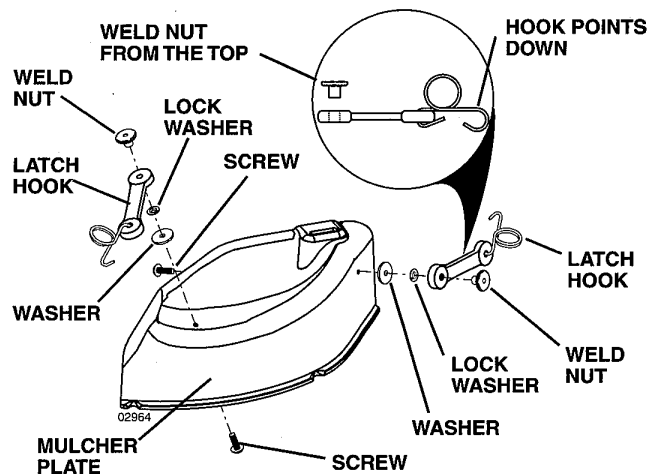

FIG. 2

CAUTION: Do not remove discharge guard from mower. Raise and hold guard when attaching mulcher plate and allow it to rest on plate while in operation.

- Raise and hold deflector shield in upright position.
- Place front of mulcher plate over front of mower deck opening and slide into place.

NOTE: On mowers so equipped, place slot in mulcher plate over tab on mower and position plate over mower opening as shown.

- Hook front latch hook into hole on front of mower deck.
- Hook rear latch hook into hole on back of mower deck.

WITHOUT GAUGE WHEELS

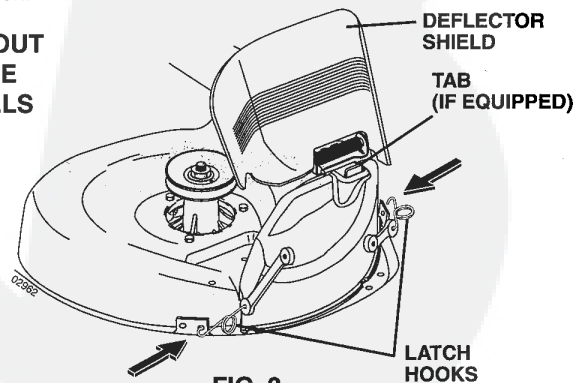

FIG. 3

199974 08.15.05 Printed in U.S.A.

- If your tractor is equipped with gauge wheels on the mower, then it will be necessary to use the hole in the R.H. gauge wheel mounting bracket.

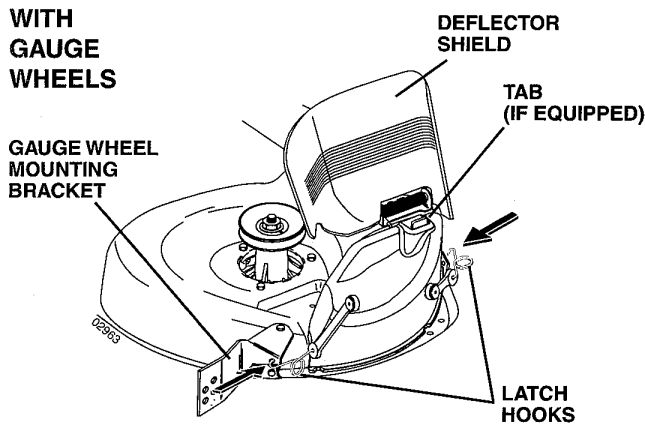

FIG. 4

TO CONVERT TO BAGGING OR DISCHARGING

Simply remove mulcher plate and store in a safe place. Your mower is now ready for discharging or installation of optional grass catcher accessory.

NOTE: It is not necessary to change blades. The mulcher blades are designed for discharging and bagging also.

MULCHING MOWING TIPS

IMPORTANT: FOR BEST PERFORMANCE, KEEP MOWER HOUSING FREE OF BUILT-UP GRASS AND TRASH. CLEAN AFTER EACH USE.

- The special mulching blade will recut the grass clippings many times and reduce them in size so that as they fall onto the lawn they will disperse into the grass and not be noticed. Also, the mulched grass will biodegrade quickly to provide nutrients for the lawn. Always mulch with your highest engine (blade) speed as this will provide the best recutting action of the blades.
- Avoid cutting your lawn when it is wet. Wet grass tends to form clumps and interferes with the mulching action. The best time to mow your lawn is the early afternoon. At this time the grass has dried and the newly cut area will not be exposed to the direct sun.
- For best results, adjust the mower cutting height so that the mower cuts off only the top one-third of the grass blades (See Fig. 5). For extremely heavy mulching, reduce your width of cut and mow slowly.

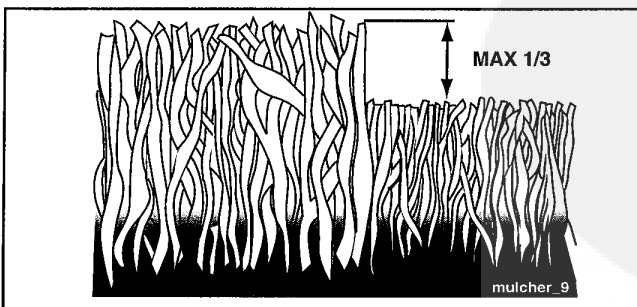

FIG. 5

- Certain types of grass and grass conditions may require that an area be mulched a second time to completely hide the clippings. When doing a second cut, mow across or perpendicular to the first cut path.
- Change your cutting pattern from week to week. Mow north to south one week then change to east to west the next week. This will help prevent matting and graining of the lawn.

FOR FUTURE REFERENCE AND REPAIR PARTS ORDERING, KEEP THIS INSTRUCTION SHEET WITH YOUR TRACTOR MANUAL

REPAIR PARTS NO. MK420B

KEY NO.	PART NO.	DESCRIPTION
1	532134149	Blade, Mulching
2	532193107	Mulcher Plate
3	532160793	Latch Hook
4	532125004	Nut, Weld
5	819061216	Washer #10
6	810071000	Washer, Lock#10
7	871081010	Screw

