

MORRISON®

EXPORT ROTARY MOWERS

Part Number
464963

Model
S16 Surecut 3n1 SP

Engine
B&S Series 300

Month and Year of First Manufacture - March 2016

Starting Serial Number - > 8020000



Issue A.0
ECN 03261
March 2016 BH
REF # 764963S



S16 Surecut SP
3'N1:
Powered by:
B&S Series 300

MORRISON

Issue A.0
ECN 03261
March 2016 BH
REF # 764963S

420mm 16" Bar Blade Assembly

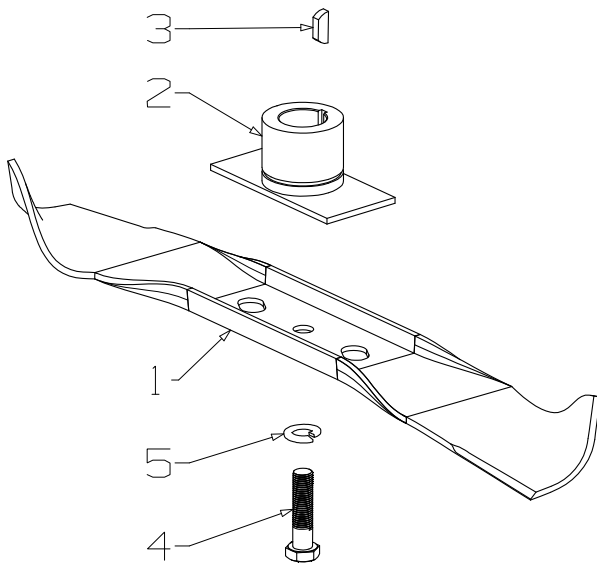

Item	Part	Description	Qty
1	564514	Blade-Bar,420mm	1
2	911106	Driver Assy-Blade, 7/8"	1
3	500636	Key-W/Ruff 5/8"x5/32"x1/4"	1
4	503543	Bolt; Hex NF 3/8"x1.5 NYG8	1
5	500204	Washer; Spg 3/8"	1

An alternative fastening may be used in this assembly

4 581610 Screw, Set NF 3/8 x 1.25 NYG8 1

764512 Catcher Assembly 16" - Fabric

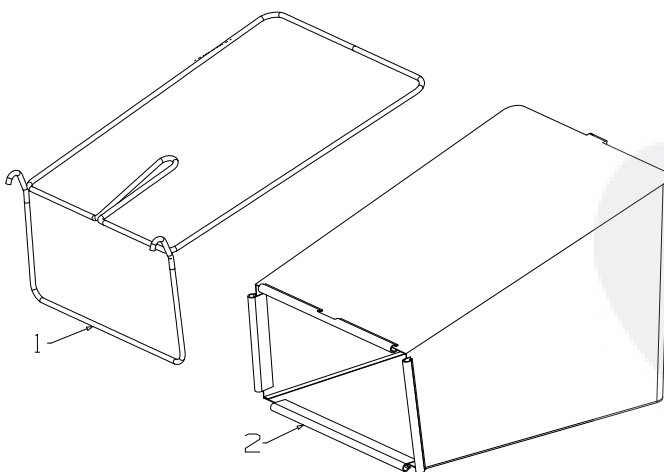

Item	Part No	Description	Qty
1	564496	Frame Assy- Catch, Fabric 16"	1
2	564513	Bag Assembly - 16" Masport	1

When ordering PLEASE QUOTE PART NUMBER & Description, NOT Illustration No.
Determine right or left hand side from standing in operating position (standing at handle).

Bold Text = Assemblies, Bulleted Text * = Items included in the Assemblies & may not be available as a spares item.



S16 Surecut SP
3'N1:
Powered by:
B&S Series 300

MORRISON®

Issue A.0
ECN 03261
March 2016 BH
REF # 764963S

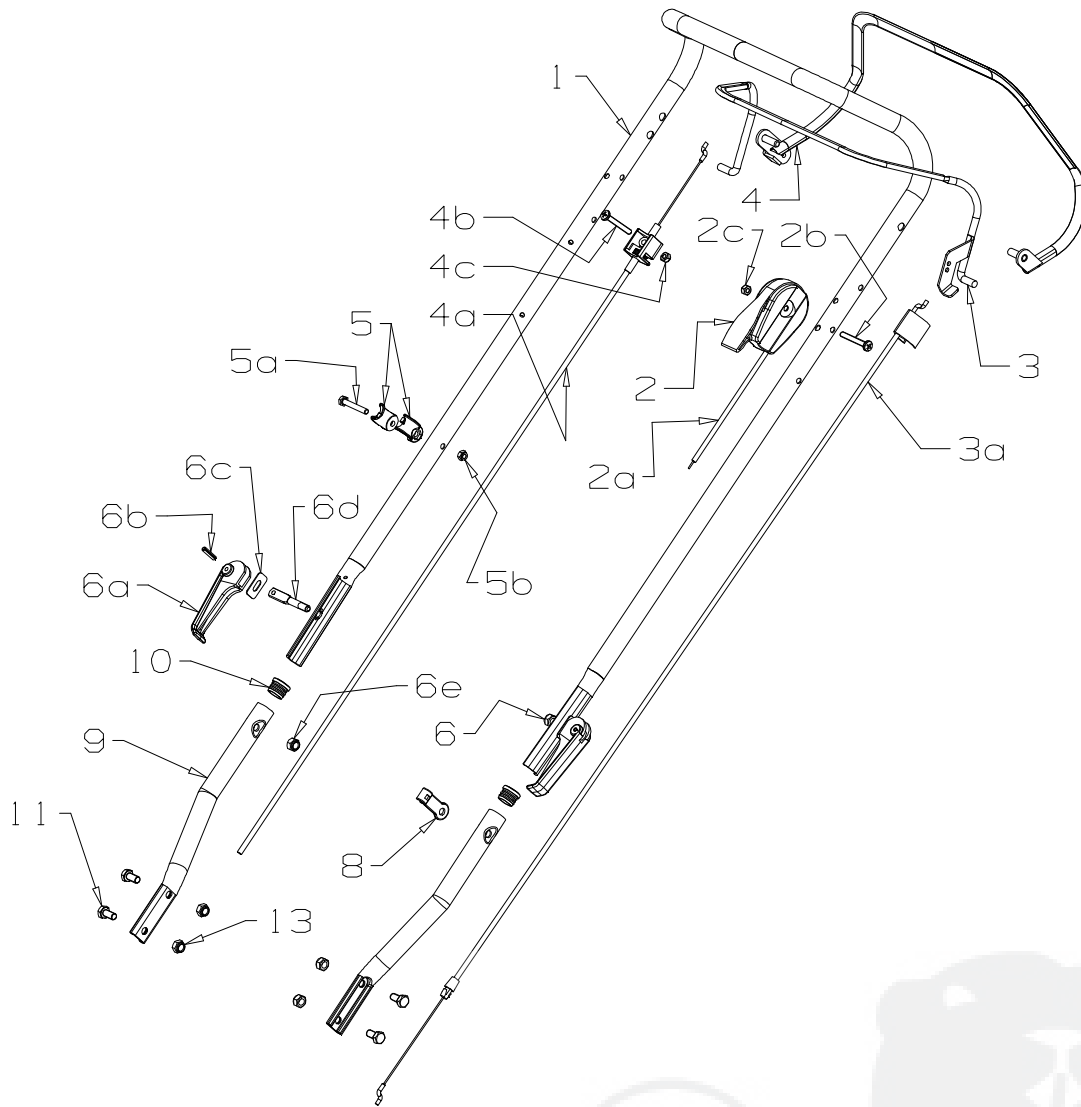

Item No	Part No	Description	Qty	Item No	Part No	Description	Qty
1	974429	Handle-Upper, Upt S16 SP Blk	1	6	779755	Cam Lock Assy- MSV	2
2/2a	583458	Throttle Ctrl & Cable, Wescon	1	6a	580313	*Lever- Handle Locking	1
2b	503604	*Screw, Pan M6 x 45 Poz	1	6b	503369	*Pin, Tension 5.0 x 22	1
2c	501764	*Nut, M6 Hex Nyloc x 6mm thick	1	6c	016777	*Washer- Slipper S/S	1
3	981740	Bail Arm Assembly- OPC, 16" Blk	1	6d	583041	*Stud- Handle Lock, 61mm	1
3a	581658	Cable- Engine, OPC Push On	1	6e	501793	*Nut, M8 Hex Nyloc x 8mm thick	1
4	974175	Bail Arm Assembly- SP, 16" Blk	1	8	581527	Retainer-Control Cable, Handle	1
4a	574214	Cable- Clutch, Thumb Wheel	1	9	974436	Handle-Lower, Stub S16 Black	2
4b	503604	Screw, Pan M6 x 45 Poz	1	10	503319	Plug-22mm Black Plastic	2
4c	501764	Nut, M6 Hex Nyloc x 6mm thick	1	11	502106	Screw, Set-M8 x 16 Hex	4
5	703856	Comfort Start Kit	1	13	501793	Nut, Nyloc M8	4
5a	503794	*Screw, Set M6 x 40	1				
5b	501764	*Nut, M6 Hex Nyloc x 6mm thick	1				

When ordering PLEASE QUOTE PART NUMBER & Description, NOT Illustration No.

Determine right or left hand side from standing in operating position (standing at handle).

Bold Text = Assemblies, Bulleted Text * = Items included in the Assemblies & may not be available as a spares item.



S16 Surecut SP
3'N1:
Powered by:
B&S Series 300

MORRISON

Issue A.0
ECN 03261
March 2016 BH
REF # 764963S

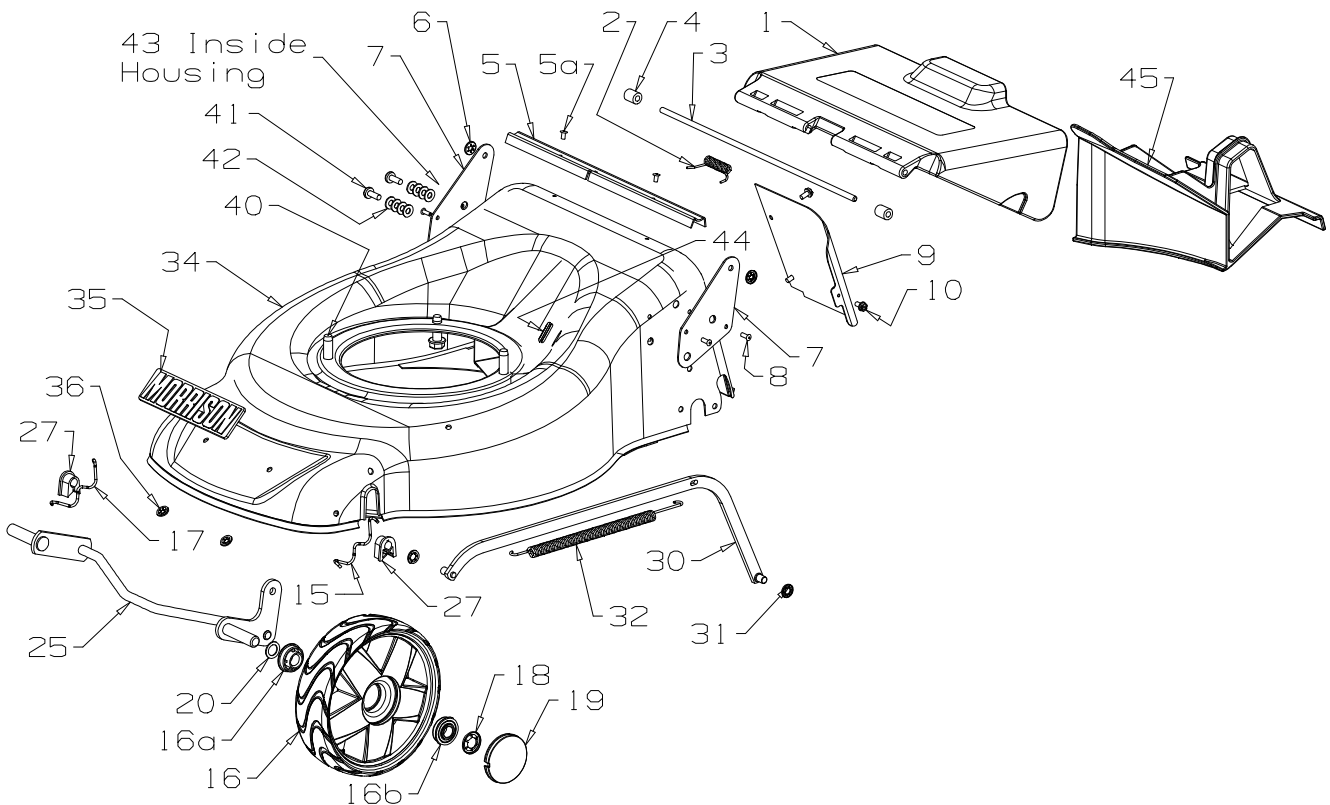

Item No	Part No	Description	Qty	Item No	Part No	Description	Qty
1	564570	Flap- Mower, 16" Black	1	31	501365	Clip-Starlock, 5/16"	2
2	581349	Spring-Flap, 18" STL	1	32	581463	Spring-Counter Balance	1
3	564503	Wire-Flap Pivot 335mm x 6mm	1	34	774378	Hsg-Assy Stl 16" Chisel SP Red	1
4	579733	Spacer-Flap	2	35	581330	Nameplate-Morrison	1
5	583151	Seal-Flap, Dust	1	36	503150	Clip-Starlock, 5 Dia	2
5a	581369	Rivet-Pop 4.0 Dia x 3.2 73SS5-2	2	40	580453	Screw; S/T 3/8 x 1-1/8" UNC Tri	3
6	503574	Clip-Starlock, 6 dia	2	41	503331	Screw, Pan M6 x 16	2
7	564517	Bracket- Flap, S16 Fabric/Catcher	2	42	501703	Washer, Flat 6 x 14 x 1.2	8
8	501303	Rivet-Pop 4.0 Dia x 7.9 73AS5-5	3	43	501764	Nut, M6 Hex Nyloc x 6mm thick	2
9	574168	Tunnel- G/Box Cover 16"	1	44	502179	Grommet- Clutch Cable, 20x16x6	1
10	503630	Screw; S/Tapping 10x .4 Typ B	4	45	574188	Insert- Mulching, 16" ST/SP	1
15	529674	Retainer- Axle, Front "W"	2				
16	579200	Wheel Assy-175, Spoked Blk (Includes 2 x 551212 per wheel)	2				
16a	579694	Bearing- Wheel, Plastic	2				
16b	551212	Bearing- Wheel, Ball Type	2				
18	503236	Clip-Starlock, 1/2"	2				
19	579202	Hub Cap- Button, Spoked Blk	2				
25	564515	Axle Assy-Front, S16- 7" Wheel	1				
27	564499	Bush- Pivot, Axle Front S16	2				
30	574173	Rod Assy-Connecting, S16 SP	1				

When ordering PLEASE QUOTE PART NUMBER & Description, NOT Illustration No.
Determine right or left hand side from standing in operating position (standing at handle).

Bold Text = Assemblies, **Bulleted Text** * = Items included in the Assemblies & may not be available as a spares item.



S16 Surecut SP
3'N1:
Powered by:
B&S Series 300

MORRISON

Issue A.0
ECN 03261
March 2016 BH
REF # 764963S

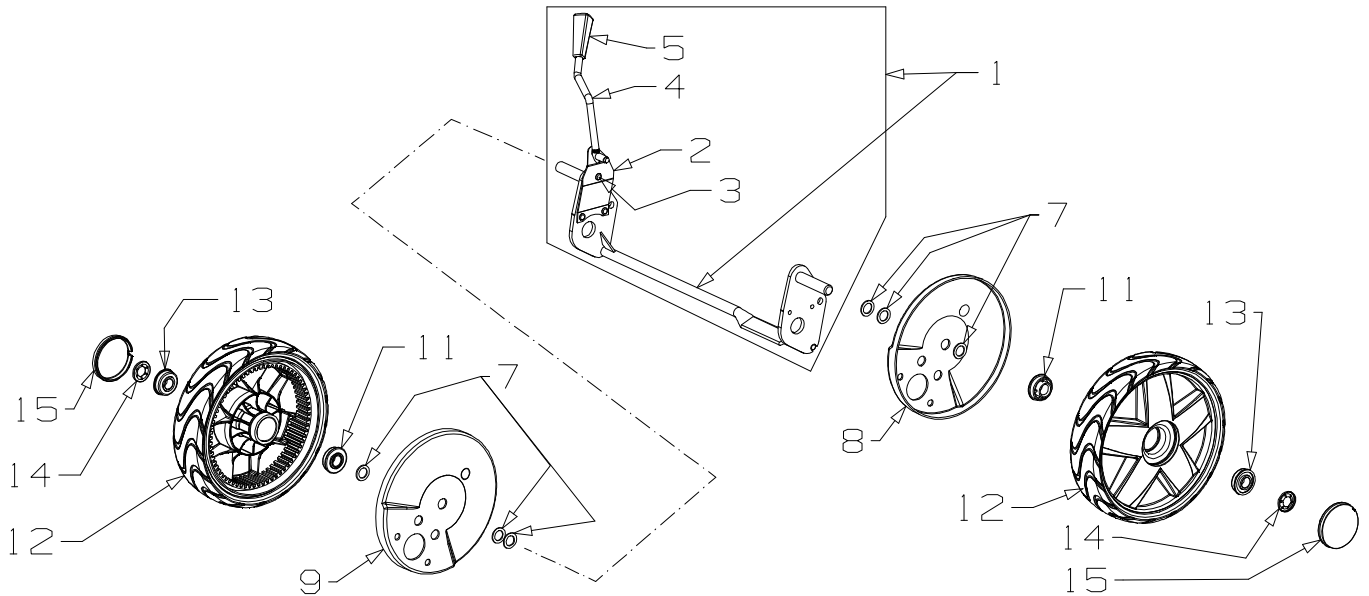

Item No	Part No	Description	Qty Req'd	NOT ILLUSTRATED	
1	774410	Axle Assy-Rear, 16" SP	1	503054	Tie- Nylon, Cable 3
2	580649	Spring-Leaf	1	564463	Decal, Hsg "Maxi Drive" 1
3	503373	Rivet-Flat Head, 3/16x27/64	3	564550	Instructions, Fab' Catcher 16" 1
4	574216	Rod-Height Selector, 16" SP	1	569160	Owners Manual-Masport Euro 1
5	580056	Knob-Height Adjust (Square)	1	571100	Decal, "Power Drive" 1
7	503301	Washer, Flat 1/2x3/4x18g	6	567522	Decal, Noise Morr Exp 98 1
8	567597	Dust Cover RH/LH	1	564684	Decal, Hsg S16 Surecut 1
9	567597	Dust Cover LH/RH	1	574316	Certificate of Conformity 1
11	579694	Bearing-Wheel, Plastic	2	582049	Decal, Flap Caution 1
12	564077	Wheel Assy -200mm SP Blk (Includes 2 x 551212 per wheel)	2		
13	551212	Bearing-Wheel, Ball Type	2		
14	503236	Clip- Starlock, 1/2"	2		
15	579202	Hub Cap- Button, Spocked Blk	2		

When ordering PLEASE QUOTE PART NUMBER & Description, NOT Illustration No.
Determine right or left hand side from standing in operating position (standing at handle).

Bold Text = Assemblies, **Bulleted Text** * = Items included in the Assemblies & may not be available as a spares item.



S16 Surecut SP
3'N1:
Powered by:
B&S Series 300

MORRISON

Issue A.0
ECN 03261
March 2016 BH
REF # 764963S

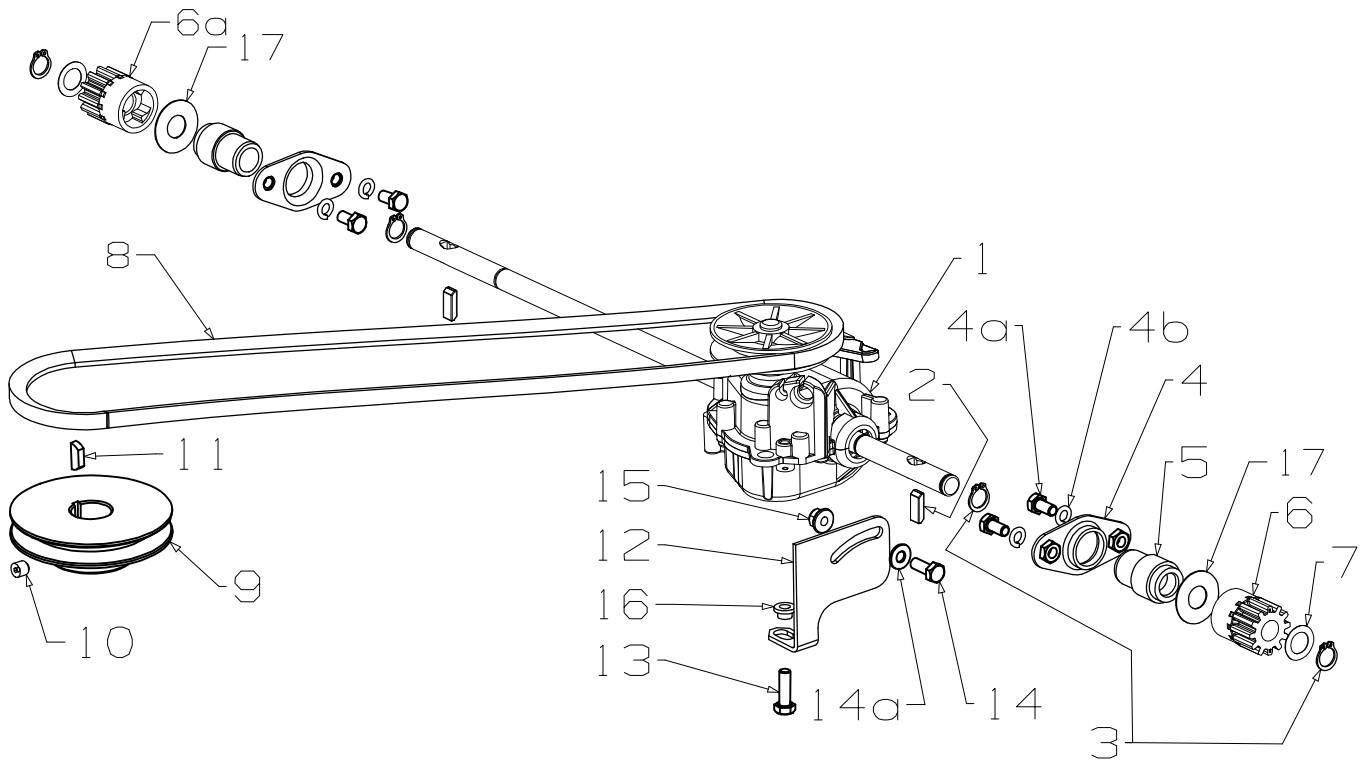

**Please Note: RH pinion must be installed on the left side,
LH pinion must be installed on the right side.**

Item No	Part No	Description	Qty	Item No	Part No	Description	Qty
1	574161	Gearbox- Single Speed Dog	1	8	574437	Belt-V Sanlux XPZ 710	1
2	581092	Pawl Pinion, 950SP	2	9	564136	Pulley-ENG, 7/8Bx89Dx28H	1
3	503759	Circlip, 12EXT DIN 471	4	10	503386	Screw, Grb M8x8	1
4	567598	Retainer Axle Rear 18" ST SP	2	11	500636	Key-W/Ruff 5/8x5/32x1/4	1
4a	501959	Screw, Set M6x12	4	12	574212	Mount-Gearbox 16" ST SP	1
4b	500201	Washer, SPG 6	4	13	501600	Screw, Set M6x20	1
5	567572	Boss - Bearing 18" ST SP LH	2	14	501702	Screw, Set M6x16	1
6	569179	Pinion - R/H, 12 Teeth	1	14a	501703	Washer, Flat 6 x 14 x 1.2	1
6a	569178	Pinion-L/H, 12 Teeth	1	15	503973	Nut, M6 Hex Nyloc	1
7	503102	Washer, FLT 12x20x0.4	2	16	564093	Bush-G/Box Mount, ST Syncro	1
				17	564092	Washer, FLT 13x30x0.6	2

When ordering PLEASE QUOTE PART NUMBER & Description, NOT Illustration No.
Determine right or left hand side from standing in operating position (standing at handle).

Bold Text = Assemblies, Bulleted Text * = Items included in the Assemblies & may not be available as a spares item.