

Schedule I: Exploded views and parts lists

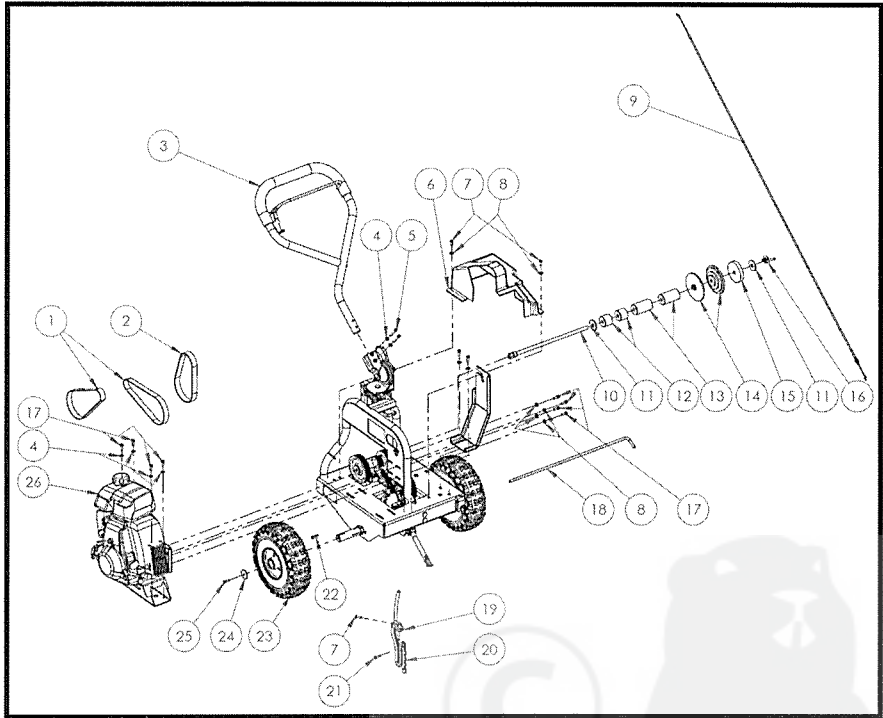

PWM600MH - PERIMETER WIRE MACHINE - 600MH		
VIEW	PART #	DESCRIPTION
1	43-0035	BELT 220-J 8 GROOVES
2	43-0044	BELT 190-J 8 GROOVES
3	70-0039	HANDLE ASS'Y
4	35-0001	INTERNAL TOOTH LOCK WASHER TYPE-A 1/4 - ZN
5	32-0027	BHCS M6-1.0 X 45mm - ZN
6	10-0243	BELT COVER
7	32-0004	BHCS M6-1.0 X 16mm - SS
8	36-0001	FLAT WASHER M6 - ZN
9	41-0015	THOTTLE CABLE ASS'Y
10	10-0348	THREADED ROD M12-1.75 X 330 - ZN
11	35-0004	FLAT WASHER 1/2 - ZN
12	10-0257	SHORT PLASTIC SPACER

13	10-0258	LONG PLASTIC SPACER
14	10-0231	SPOOL CENTER HUB
15	10-0220	RUBBER DAMPER
16	10-0265	WING NUT
17	32-0039	SHCS M6-1 X 16mm - BLACK
18	10-0214	DISTANCE ROD
19	70-0056	WIRE GUIDE ASS'Y
20	10-0303	BLADE TYPE 7
21	32-0014	REAMER BOLT M6-1.0 X 23 - BLACK
22	43-0034	KEY 1/4 X 1/4 X 1
23	44-0038	TIRE AND HUB 4.10 X 10
24	10-0102	RETAINING WASHER 1/4 X 1-1/4 - ZN
25	32-0005	BHCS M6-1.0 X 20mm - SS
26	70-0036	ENGINE ASS'Y

Schedule II: Characteristics of GS-1000 Prolab synthetic grease

Characteristics	ASTM test	Typical values
Appearance		Beige
N.L.G.I. grade		2
Viscosity at 40°C	D445	46 cSt
Viscosity at 100°C	D445	8 cSt
Viscosity index	D2270	145
Dropping point	D2265	300°C