

1713761
322-0500

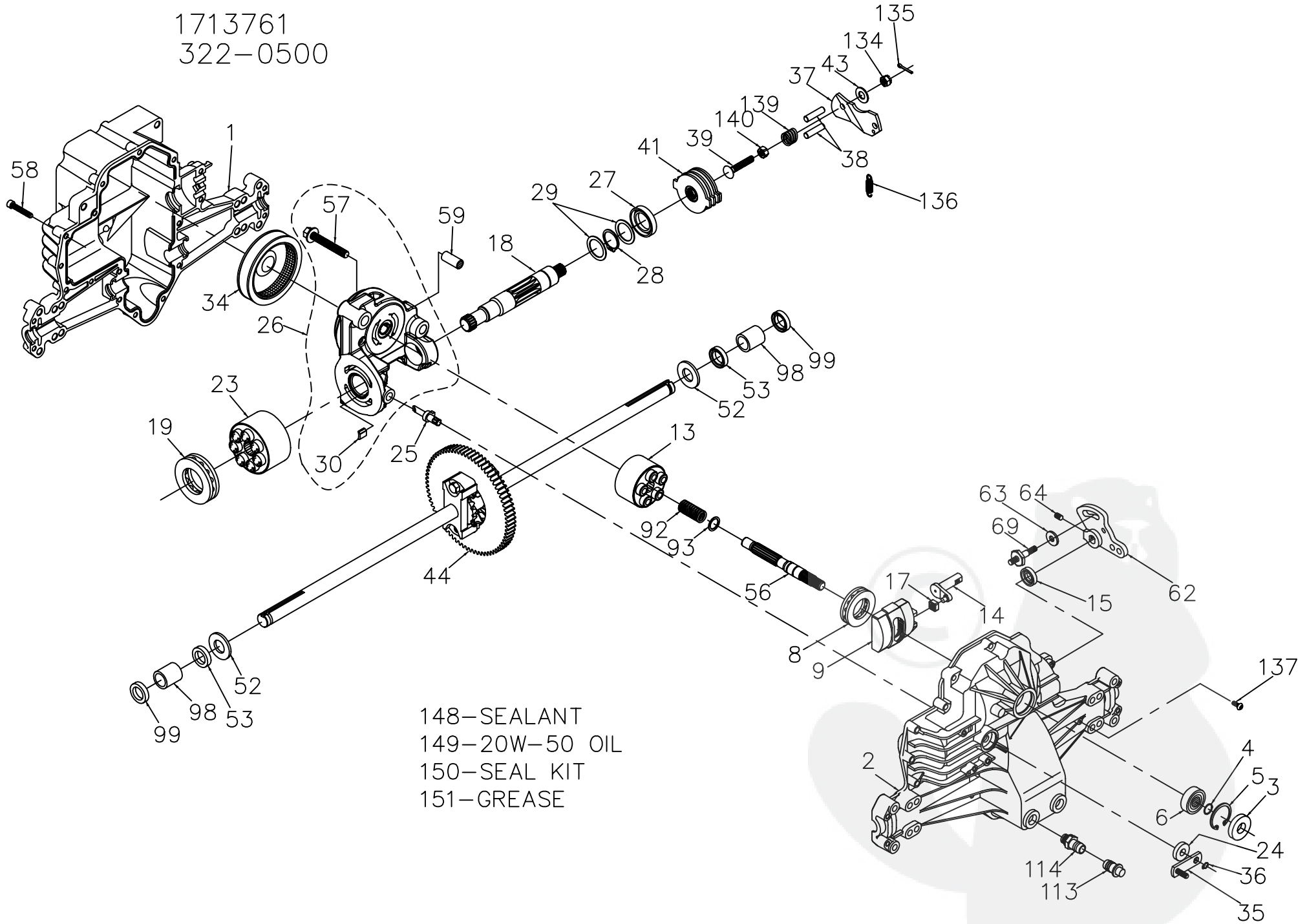

1713761
322-0500

| ITEM NO | HYDRO-GEAR PART NO | QTY | DESCRIPTION |
|---------|--------------------|-----|---------------------------|
| 1 | 44863RM | 1 | HOUSING, LOWER |
| 2 | 70254 | 1 | ASSEMBLY, UPPER HOUSING |
| | | 1 | UPPER HOUSING |
| | | 1 | TRUNNION JOURNAL BEARING |
| 3 | 9008000-0128 | 1 | SEAL-LIP |
| 4 | 2003016 | 1 | RING-WIRE RETAINING |
| 5 | 2003052 | 1 | RING-RETAINING |
| 6 | 2003043 | 1 | BEARING-SHAFT BALL |
| 8 | 50551 | 1 | BEARING-THRUST 30X52X13 |
| 9 | 2003087 | 1 | SWASHPLATE-VARIABLE |
| 13 | 70331 | 1 | BLOCK-CYLINDER ASS'Y. |
| | | 1 | BLOCK-CYLINDER |
| | | 5 | PISTON |
| | | 5 | PISTON SPRING |
| | | 5 | PISTON SPRING WASHER |
| 14 | 2003005 | 1 | ARM-TRUNNION |
| 15 | 9008000-0126 | 1 | SEAL-LIP |
| 17 | 2000015 | 1 | GUIDE-SLOT |
| 18 | 50449 | 1 | SHAFT-MOTOR |
| 19 | 50552 | 1 | BEARING-THRUST 42X68X16 |
| 23 | 70082 | 1 | BLOCK-CYLINDER ASS'Y. |
| | | 1 | BLOCK-CYLINDER |
| | | 7 | PISTON |
| | | 7 | PISTON SPRING |
| | | 7 | PISTON SPRING WASHER |
| 24 | 45074 | 1 | SEAL-LIP 10X25X7 |
| 25 | 2003555 | 1 | ACTUATOR-BYPASS |
| 26 | 70250 | 1 | KIT, CENTER SECTION |
| | | 1 | PLATE, BYPASS |
| | | 2 | CHECK PLUG ASSEMBLY |
| | | 1 | CENTER SECTION |
| | | 1 | DU BEARING |
| | | 3 | BOLT, 3/8-24 X 2.5 |
| | | 1 | BUSHING, 1.02 X 1.1 X .67 |
| 27 | 45075 | 1 | SEAL-LIP 26X42X8 |
| 28 | 50007 | 1 | RING-RETAINING |
| 29 | 44872 | 2 | WASHER-26X35X1 |
| 30 | 70680 | 1 | KIT, BYPASS PLATE |
| 34 | 50990 | 1 | FILTER |
| 35 | 50126 | 1 | ARM-BYPASS |
| 36 | 44870 | 1 | RING-RETAINING |
| 37 | 50130 | 1 | ARM-ACTUATING |
| 38 | 44891 | 2 | PIN-ACTUATING |

| ITEM NO | HYDRO-GEAR PART NO | QTY | DESCRIPTION |
|---------|--------------------|------|----------------------------|
| 39 | 50316 | 1 | BOLT-5/16-24 X 1-3/4 |
| 41 | 70135 | 1 | BRAKE ROTOR/STATOR KIT |
| | | 4 | BRAKE STATOR |
| | | 2 | BRAKE ROTOR |
| 43 | 44130 | 1 | WASHER-7/16 X 7/8 X .060 |
| 44 | 70126 | 1 | DIFFERENTIAL ASSEMBLY |
| | | 2 | AXLE SHAFT |
| | | 1 | 72T DIFFERENTIAL GEAR |
| | | 2 | DIFFERENTIAL HOUSING |
| | | 2 | 14T BEVEL GEAR |
| | | 2 | 10T PLANET GEAR |
| | | 2 | RETAINING RING |
| | | 2 | DIFFERENTIAL LOCKING BOLT |
| | | 1 | DIFFERENTIAL SPACER |
| 52 | 44875 | 2 | WASHER-3/4 X 1.5 X .13 |
| 53 | 45076 | 2 | SEAL- .75 X 1.25 X .250 |
| 56 | 50005 | 1 | SHAFT-INPUT |
| 57 | 50016 | 3 | BOLT, 3/8-24 X 2.5 |
| 58 | 44876 | 20 | BOLT- 1/4-20 X 1.38 |
| 59 | 50002 | 2 | PIN- .5 OD X .43 ID X .750 |
| 62 | 45007 | 1 | ARM-CONTROL |
| 63 | 50281 | 1 | PUCK-DAMPENER |
| 64 | 50018 | 1 | SET SCREW |
| 69 | 50426 | 1 | 5/16-24 STUD |
| 92 | 2003014 | 1 | SPRING, BLOCK |
| 93 | 2003017 | 1 | WASHER, BLOCK THRUST |
| 98 | 50137 | 2 | SLEEVE BEARING |
| 99 | 50941 | 2 | SEAL, LIP 0.75X1.00X0.158 |
| 113 | 70109 | 1 | CAP-VENT ASSEMBLY |
| | | 1 | CAP-POPPET VALVE |
| | | 1 | PLASTIC VENT |
| 114 | 70110 | 1 | FITTING-O RING ASSEMBLY |
| | | 1 | O-RING |
| | | 1 | PLASTIC HOSE FITTING |
| 134 | 44142 | 1 | CASTLE NUT, 5/16-24 |
| 135 | 44101 | 1 | COTTER PIN |
| 136 | 50384 | 1 | EXTENSION SPRING |
| 137 | 50653 | 1 | SCREW, 10-32 X 1/2 |
| 139 | 50431 | 1 | COMPRESSION SPRING |
| 140 | 50269 | 1 | NUT, HEX 5/16-24 |
| 148 | 50928 | 1 | SEALANT |
| 149 | | 77oz | 20W-50 OIL |
| 150 | 70312 | 1 | SEAL KIT |
| 151 | 50416 | 1 | GREASE |

