

157981  
314-3000

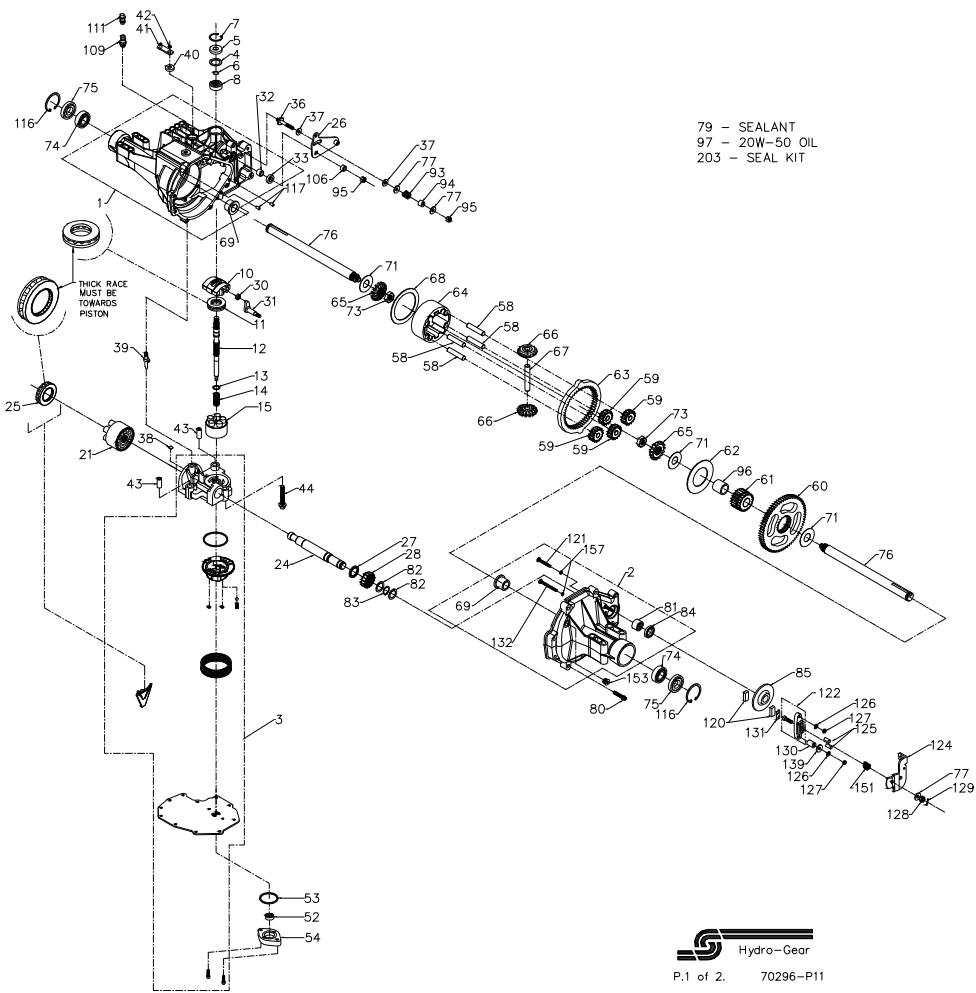

157981  
314-3000

ITEM #	PART #	QTY	DESCRIPTION		
1	70297	1	MAIN HOUSING ASSEMBLY		
		1	MAIN HOUSING		
		1	LIP SEAL		
		1	FLANGE BEARING		
		1	TRUNNION BUSHING		
		2	CRADLE BEARING		
2	70298	1	R.H. HOUSING ASSEMBLY		
		1	R.H. HOUSING		
		1	FLANGE BEARING		
		2	O RING		
		1	RIB NECK BOLT, 2"		
		1	RIB NECK BOLT, 3"		
		1	NEEDLE BEARING(SC1412)		
		1	SEAL, LIP .875 X 1.38 X .25		
		3	70449	1	KIT, MANIFOLD
				1	KIT, CENTER SECTION
1	CENTER SECTION				
1	BEARING .50 X .60 X .50				
1	BUSHING .90 X 1.02 X .75				
1	PLATE, BYPASS				
1	CHECK PLUG ASSEMBLY, .044				
1	CHECK PLUG ASSEMBLY, NO BLEED				
2	CAPSCREW M6X1-22				
1	COVER, LOWER				
1	KIT, FILTER				
1	MANIFOLD, CHARGE				
1	RETAINER, MOTOR BEARING				
1	O RING .103X2.987				
1	SPRING, RELIEF				
1	BALL 7/16				
2	O-RING .070X.239				
4	2003018	1	SPACER		
5	9008000-0128	1	SEAL-LIP		
6	2003016	1	WIRE RETAINING RING		
7	2003052	1	RETAINING RING		
8	2003043	1	BALL BEARING		
10	2003087	1	VARIABLE SWASHPLATE		
11	50551	1	THRUST BEARING 30 X 52 X 13		
12	50795	1	INPUT SHAFT		
13	2003017	1	BLOCK THRUST WASHER		
14	2003014	1	BLOCK SPRING		
15	70331	1	10cc CYLINDER BLOCK ASSEMBLY		
		5	10cc CYLINDER BLOCK		
		5	10cc PISTON		
		5	10cc PISTON SPRING		
		5	PISTON SEAT WASHER		
21	70082	1	21cc CYLINDER BLOCK ASSEMBLY		
		1	21cc CYLINDER BLOCK		
		7	PISTON SEAT WASHER		
		7	21cc PISTON		
		7	21cc PISTON SPRING		
24	50662	1	OUTPUT (MOTOR) SHAFT		
25	50552	1	THRUST BEARING 42 X 68 X 16		
26	50857	1	CONTROL ARM		
27	50774	1	SPACER		
28	50661	1	16T PINION GEAR		

ITEM #	PART #	QTY	DESCRIPTION
30	2000015	1	SLOT GUIDE
31	50807	1	TRUNNION ARM
32	2003009	1	TRUNNION BUSHING
33	9008000-0126	1	LIP SEAL
36	50284	1	5/16-24 STUD
37	50281	2	PUCK, FRICTION
38	70680	1	KIT, BYPASS PLATE
39	2003555	1	BYPASS ACTUATOR
40	45074	1	LIP SEAL
41	50270	1	BYPASS ARM
42	44870	1	RETAINING RING
43	50002	2	PIN
44	50016	3	SCREW
52	50273	1	GEROTOR ASSEMBLY
53	9004101-1340	1	O-RING
54	50260	1	GEROTOR COVER
58	50776	4	PIN, CARRIER
59	50763	4	15T PLANET GEAR
60	50646	1	67T SPUR GEAR
61	50645	1	21 TOOTH SUN GEAR
62	50769	1	PLANET THRUST PLATE
63	50764	1	51T RING GEAR
64	50765	1	PLANETARY CARRIER
65	50647	2	MITER GEAR, DIFF. (SPLINED)
66	50648	2	MITER GEAR, DIFF.
67	50766	1	SHAFT, DIFFERENTIAL
68	50767	1	DIFF. THRUST PLATE
69	50768	2	FLANGE BEARING
71	50788	3	WASHER 1.0 X 2.25 X .04
73	50791	2	HEX JAM NUT, 5/8-18
74	50771	2	BEARING, BALL 6205-1
75	50772	2	SEAL, 1" ID X 2.0472 X 0.375
76	50663	2	SHAFT, AXLE
77	44130	3	WASHER
79	50928	1	GASKET MATERIAL
80	50868	8	TORX HEAD SCREW, 5/16-18
81	44752	1	NEEDLE BEARING (SCE1412)
82	50777	2	WASHER
83	50775	1	RETAINING RING
84	50773	1	LIP SEAL (.875 I.D. X 1.30 D. X .25)
85	50779	1	BRAKE DISK
93	50866	1	SLEEVE BEARING
94	50277	1	SPRING, FRICTION PACK
95	50278	1	SPACER, FRICTION PACK
97	50108	2	HEX LOCK NUT 5/16-24
		122oz	20W-50 OIL

ITEM #	PART #	QTY	DESCRIPTION
106	50850	1	SPACER, TRUNNION
109	70110	1	FITTING-O RING ASSEMBLY
111	70109	1	CAP-VENT ASSEMBLY
116	50859	2	RETAINING RING
117	9004800-2506	2	STD HDLS PIN
120	44132	2	PUCK, BRAKE
121	50874	1	RIB NECK BOLT 2"
122	70633	1	BRAKE YOKE ASSEMBLY
124	50916	1	ARM, BRAKE
125	44127	2	PINS, BRAKE
126	43177	2	LOCKWASHER, 1/4"
127	43178	2	NUT, 1/4-20
128	44142	1	NUT, CASTLE
129	44101	1	COTTER PIN
130	23711	1	SPACER
131	44134	1	PUCK PLATE
132	50865	1	RIB NECK BOLT 3"
139	44278	1	WASHER, 7/800 X .265ID X .125 THK
151	50919	1	COMP. SPRING, BRAKE ANTI-DRAW
153	9005110-5600	1	PLUG, STRAIGHT THREAD
157	50977	2	O-RING, .070 X .239
203	70492	1	KIT, SEAL
		1	SEAL-LIP 15X5X37
		1	SEAL-LIP 12X25X7
		1	SEAL-LIP 10X25X7
		1	O-RING, .103X1.862
		2	SEAL 25X52X10
		1	LIP SEAL (.875 I.D. X 1.3 O.D. X .25)
		4	O-RING, .070X.239
		1	KIT, O-RING, MANIFOLD