

HCS-3210ES

Serial Number

37000001-37999999

Last updated date

27/Nov/2020

TABLE OF CONTENTS

CYLINDER, PISTON, CRANKSHAFT	1
CRANKCASE	3
MAGNETO.....	5
AIR CLEANER, CARBURETOR.....	7
CARBURETOR.....	9
FUEL TANK	11
MUFFLER.....	13
RECOIL STARTER.....	15
GEAR CASE	17
CUTTING BLADE	19
MAIN PIPE, HANDLE.....	21
ACCESSORIES	23

CYLINDER, PISTON, CRANKSHAFT

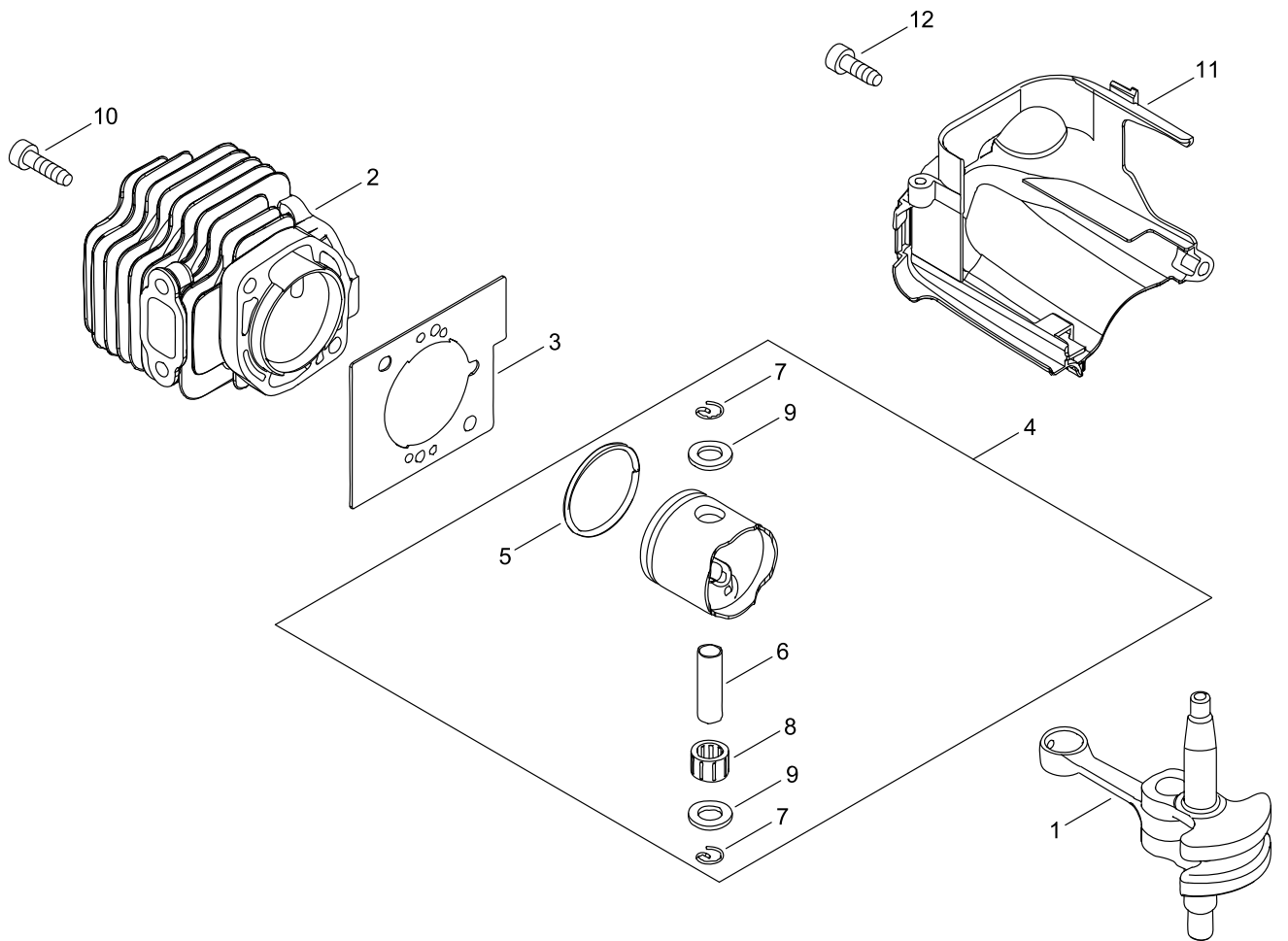

CYLINDER, PISTON, CRANKSHAFT

Key No.	LV (+)	Parts Number	Parts Description	Qty	Standard	Class
1		A011-001180	CRANKSHAFT,ASY	1		D
2		A130-001960	CYLINDER	1		D
3		V100-000720	GASKET,CYL	1		B
4		P021-037930	PISTON KIT	1		
5	+	A101-000090	RING,PISTON	1		B
6	+	V606-000020	PIN,ENG 8	1	5.8*8*25.5	D
7	+	100015-04630	CIRCLIP, PISTON PIN	2		C
8	+	100113-05930	BEARING, NEEDLE	1	8*12*8	B
9	+	100014-08960	SPACER, PISTON PIN	2		C
10		V203-000170	BOLT,5	2	5*22	C
11		A160-002470	COVER,CYLINDER	1		C
12		V805-000150	BOLT, TORX 5	1	TB-5*16 10.9	C

Class : Consumable class

A:Fast moving parts B:Semi-fast moving parts C:Slow moving parts D:Order only as needed

CRANKCASE

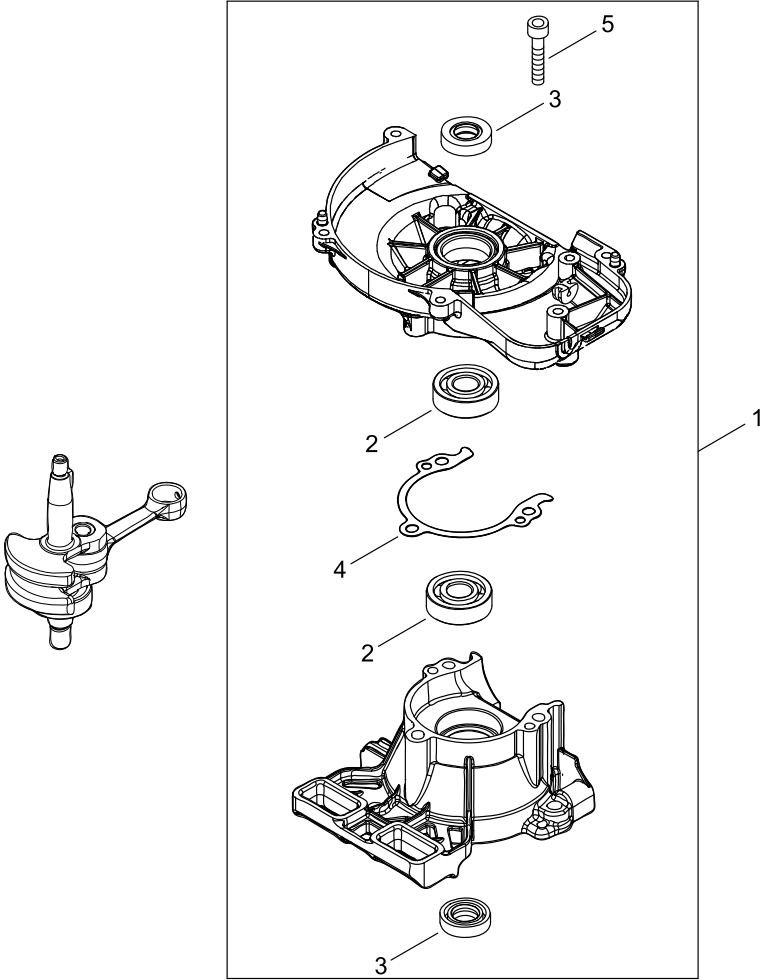

CRANKCASE

Key No.	LV (+)	Parts Number	Parts Description	Qty	Standard	Class
1		P100-001510	CRANK CASE SET	1		
2	+	900810-36000	BEARING, BALL	2	6000	
3	+	100212-61830	OILSEAL	2	ISCD 10*20*5	C
4	+	V102-000240	GASKET,CRANKCASE	1		B
5	+	91128-05028	BOLT HSH	3	5*28	

Class : Consumable class

A:Fast moving parts B:Semi-fast moving parts C:Slow moving parts D:Order only as needed

MAGNETO

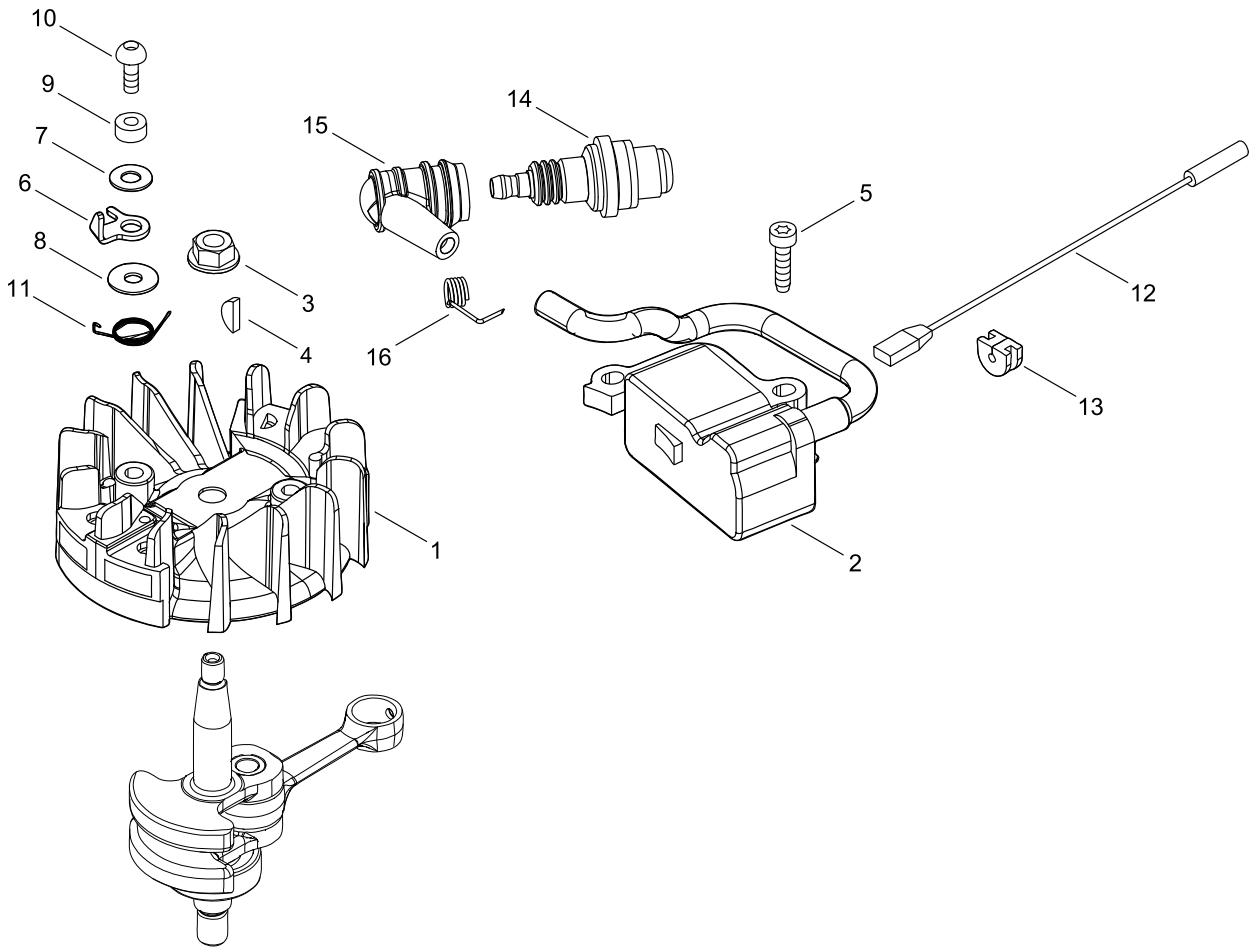

MAGNETO

Key No.	LV (+)	Parts Number	Parts Description	Qty	Standard	Class
1		A409-001120	ROTOR, MAGNETO	1		C
2		A411-001801	COIL, IGNITION	1	A10054識別B	C
3		92105-06000	NUT, FLANGE	1	M6*1.0 L	
4		100142-12330	KEY, WOODRUFF	1		C
5		V804-000100	BOLT, TORX 4	2	TB-4*16 12.9	C
6		A514-000260	PAWL	2		C
7		900603-00005	WASHER 5	2	5.5*12*0.8	
8		131911-03460	WASHER	2		C
9		178070-10860	SPACER	2		C
10		V203-000080	BOLT,5	2	5*14	C
11		V452-001370	SPRING,TORSION	2		B
12		V485-001220	LEAD	1	L:85	C
13		156114-04920	GROMMET	1		C
14		A425-000000	SPARKPLUG	1	BPMR8Y	A
15		A427-000013	CAP,SPARK PLUG	1		C
16		A426-000010	TERMINAL,SPARKPLUG	1		C

Class : Consumable class

A:Fast moving parts B:Semi-fast moving parts C:Slow moving parts D:Order only as needed

AIR CLEANER, CARBURETOR

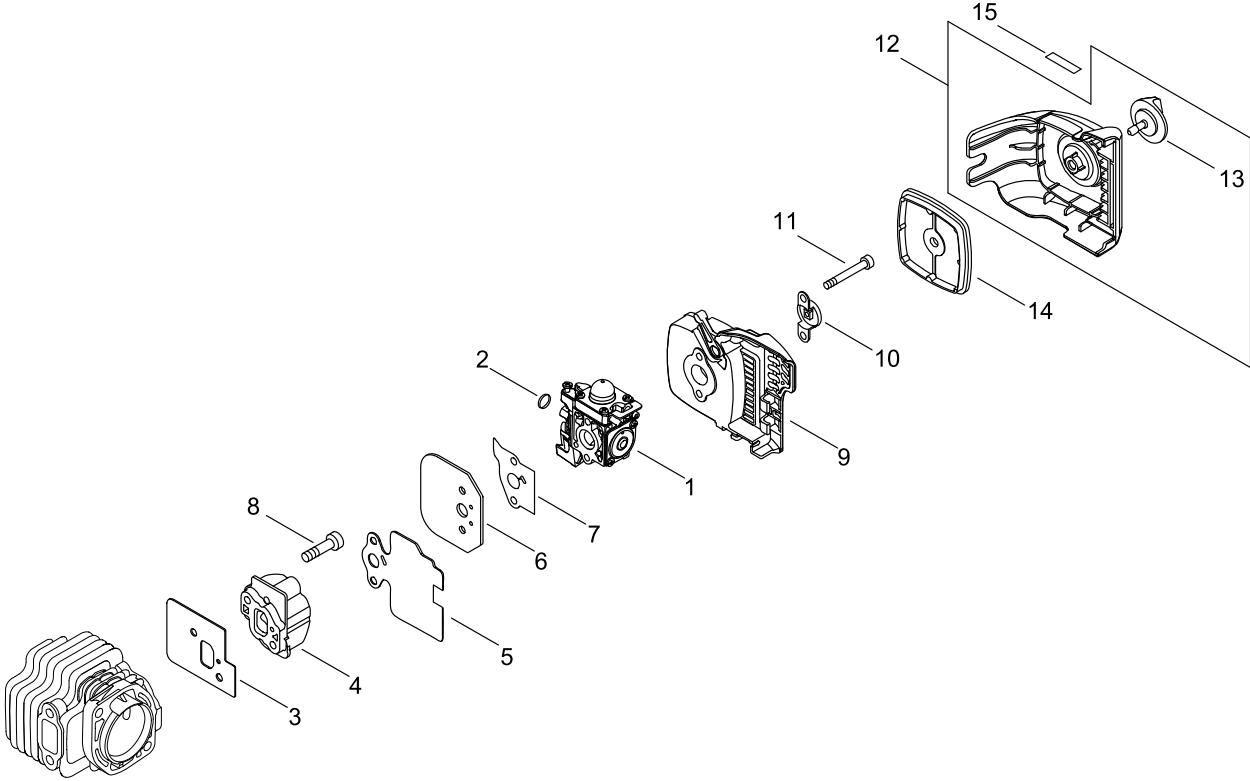

AIR CLEANER, CARBURETOR

Key No.	LV (+)	Parts Number	Parts Description	Qty	Standard	Class
1		A021-004670	CARBURETOR,DIAPHRAGM	1	RB-K119	B
2		V490-001100	CLIP	1		C
3		V103-001401	GASKET,INTAKE	1		A
4		A200-000941	INSULATOR, INTAKE	1		C
5		V103-001410	GASKET,INTAKE	1		A
6		A209-000610	PLATE, INSULATOR	1		C
7		V103-001740	GASKET,INTAKE	1		A
8		V805-000170	BOLT, TORX 5	2	TB-5*25 10.9	C
9		P021-046091	CASE,CLEANER	1		
10		A244-000070	PLATE,PREVENT	1		C
11		V805-000100	BOLT, TORX 5	2	TB-5*65 10.9	C
12		P021-046100	LID,CLEANER ASY	1		
13	+	V299-000410	KNOB	1		C
14		A226-001410	ELEMENT,AIR FILTER	1		A
15		890332-52730	LABEL, CHOKE	1		D

Class : Consumable class

A:Fast moving parts B:Semi-fast moving parts C:Slow moving parts D:Order only as needed

CARBURETOR

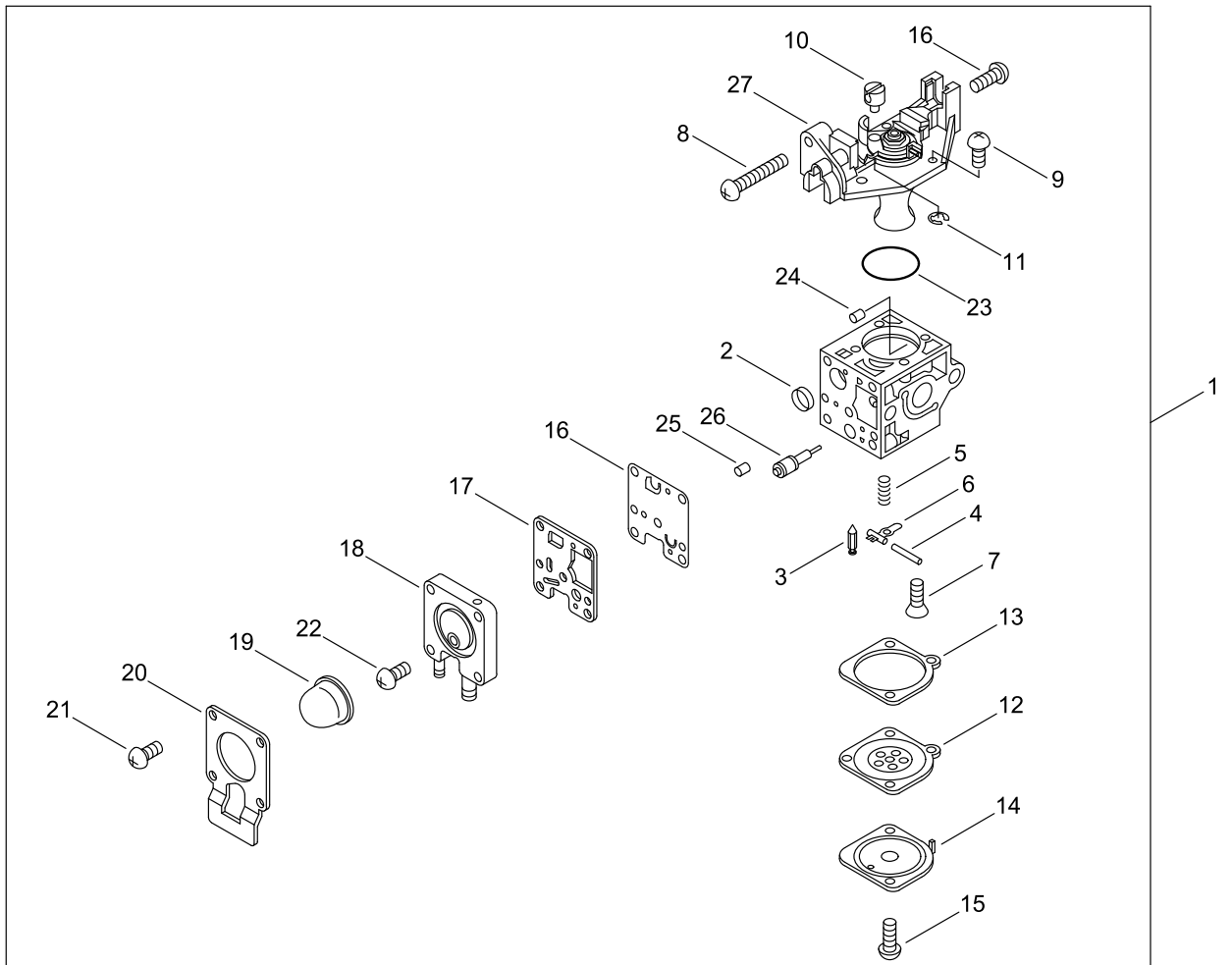

CARBURETOR

Key No.	LV (+)	Parts Number	Parts Description	Qty	Standard	Class
1		A021-004670	CARBURETOR,DIAPHRAGM	1	RB-K119	B
2	+	P005-000010	STRAINER	1		
3	+	125337-08260	VALVE, INLET NEEDLE	1		
4	+	125338-13930	PIN, METERING ARM	1		
5	+	P005-000940	SPRING, METER. LEVER	1		
6	+	125323-08260	ARM, VALVE	1		
7	+	125339-42030	SCREW	1		
8	+	P005-000100	SCREW,THROTTLEADJUST	1		
9	+	125344-13931	SCREW	3		
10	+	P005-002200	POST	1		
11	+	P005-000190	E-RING	1		
12	+	P005-002230	DIAPHRAGM ,METERING	1		A
13	+	P005-000200	GASKET, METERING	1		A
14	+	125342-52130	COVER, DIAPHRAGM	1		
15	+	125344-52130	SCREW	3		
16	+	P005-000510	DIAPHRAGM, PUMP	1		A
17	+	P005-000520	GASKET, PUMP	1		A
18	+	P005-004240	BASE, ASY PRIMER	1		
19	+	P005-003110	PUMP, PRIMER	1		
20	+	P005-000250	RETAINER	1		
21	+	P005-001900	SCREW	4		
22	+	P005-000270	SCREW	1		
23	+	P005-000280	O-RING	1		
24	+	P005-001000	ROLLER, GUIDE	1		
25	+	P005-001250	RETAINER,PLUG BALL	1		
26	+	P005-001260	SCREW,MAINN MIXTURE	1		
27	+	P005-002050	COVER ASY, ROTOR	1		

Class : Consumable class

A:Fast moving parts B:Semi-fast moving parts C:Slow moving parts D:Order only as needed

FUEL TANK

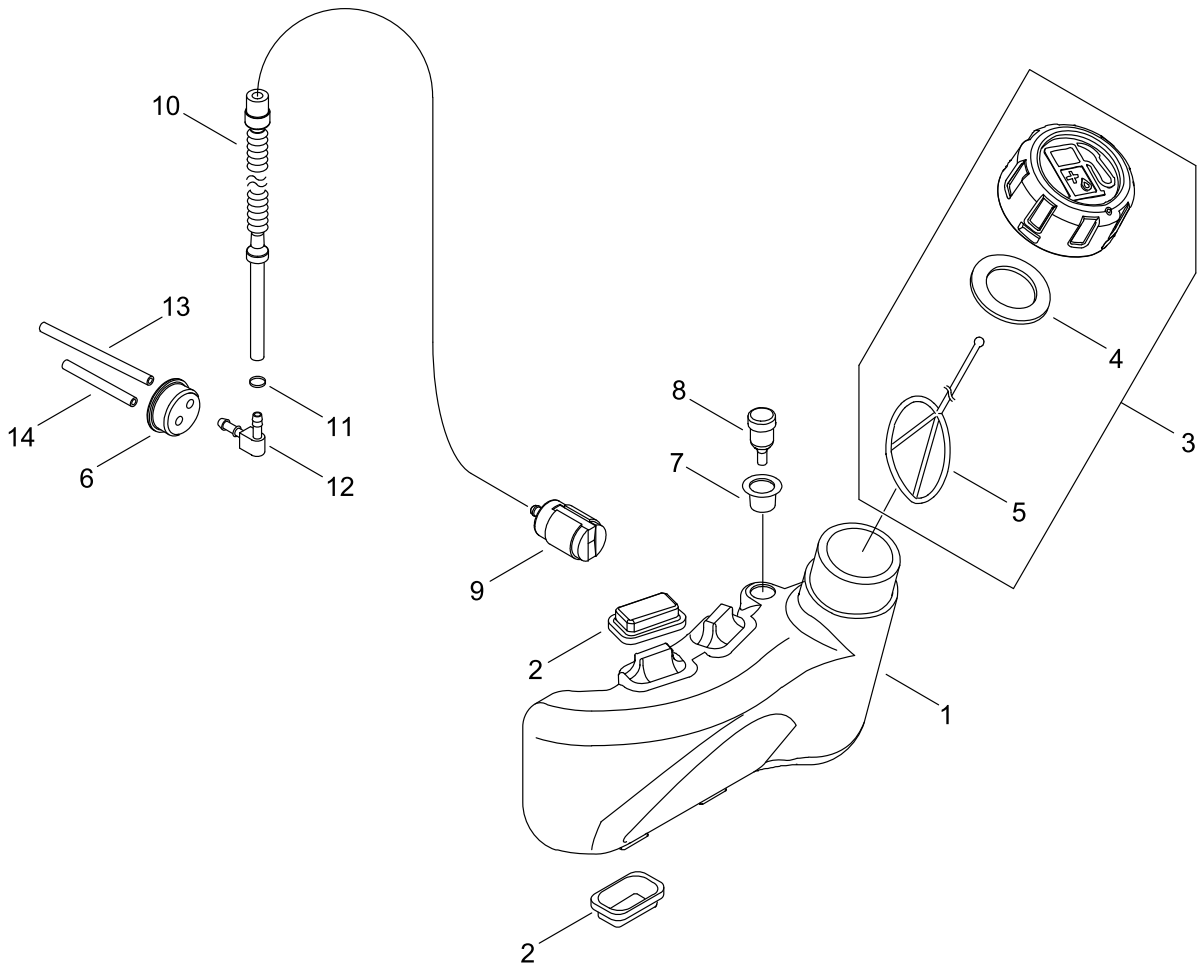

FUEL TANK

Key No.	LV (+)	Parts Number	Parts Description	Qty	Standard	Class
1		A350-001880	TANK, FUEL	1		C
2		V420-004490	CUSHION	4		B
3		P021-046081	FUEL CAP ASY	1		
4	+	V107-000190	GASKET, FUEL CAP	1	37.9* T 2.2	A
5	+	A365-000060	CONNECTOR, CAP	1	L=123	B
6		132115-44331	GROMMET, FUEL	1		C
7		V137-000001	GROMMET, FUEL	1		C
8		A356-000031	VALVE, CHECK	1		B
9		131205-07321	STRAINER, FUEL	1		A
10		V471-003511	PIPE	1	V471224000Xカット	C
11		V490-000500	CLIP	1		C
12		V186-000270	JOINT, PIPE	1		C
13		V471-003501	PIPE	1	3*6*92	C
14		132010-49730	PIPE 3*6*85	1	3*6*85 YL	C

Class : Consumable class

A:Fast moving parts B:Semi-fast moving parts C:Slow moving parts D:Order only as needed

MUFFLER

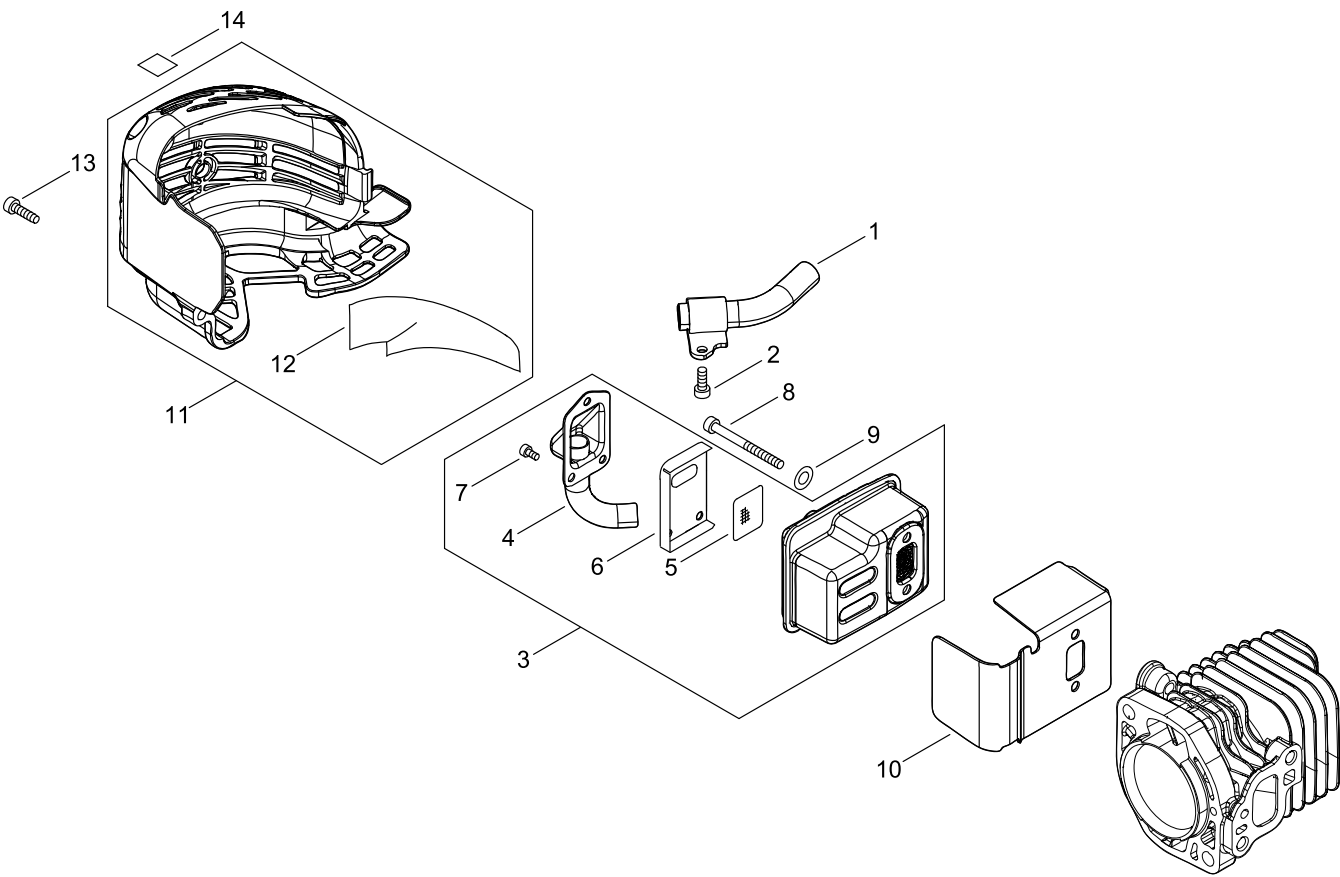

MUFFLER

Key No.	LV (+)	Parts Number	Parts Description	Qty	Standard	Class
1		A313-001730	GUIDE, EXHAUST	1		C
2		V805-000130	BOLT, TORX 5	1	TB-5*10 10.9	C
3		P021-041970	MUFFLER ASY	1		
4	+	A313-001741	GUIDE,EXH	1		C
5	+	A310-000070	SCREEN, ARRESTOR	1	22*28*3	B
6	+	V104-000072	GASKET,EXHAUST	1		A
7	+	V804-000030	BOLT, TORX 4	3	TB-4*8 10.9	C
8		V805-000190	BOLT, TORX 5	2	TB-5*55 12.9	C
9		900603-00005	WASHER	2	5	
10		V104-001831	GASKET,EXHAUST	1		A
11		P100-002061	MUFFLER COVER ASY	1		
12	+	A209-000621	PLATE, INSULATOR	1	HT2210S T2.0	C
13		V805-000150	BOLT, TORX 5	2	TB-5*16 10.9	C
14		X505-002310	LABEL,CAUTION	1	HOT CAUTION	D

Class : Consumable class

A:Fast moving parts B:Semi-fast moving parts C:Slow moving parts D:Order only as needed

RECOIL STARTER

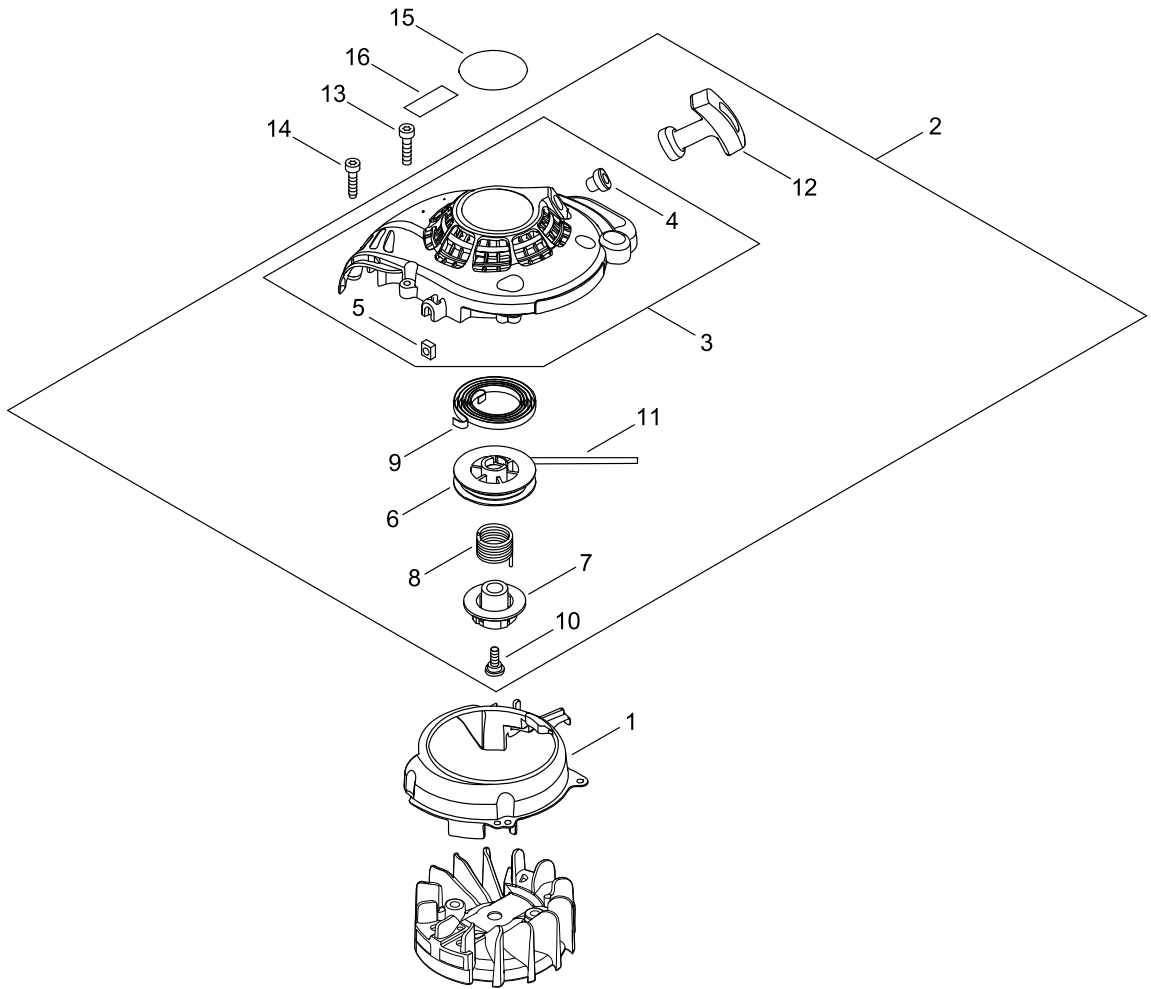

RECOIL STARTER

Key No.	LV (+)	Parts Number	Parts Description	Qty	Standard	Class
1		A172-001990	COVER,FAN	1		C
2		A051-002373	STARTER,RECOIL ASY	1		B
3	+	P022-053050	STARTER,RECOIL	1		
4	++	P022-045770	GUIDE, ROPE	1		
5	++	900565-00005	NUT	1	5	
6	+	P022-027980	DRUM, STARTER	1		
7	+	P022-037310	PLATE, CAM	1		
8	+	P022-008270	SPRING,DAMPER	1		
9	+	177220-42030	SPRING, REWIND	1		
10	+	177236-61830	SCREW	1		
11	+	P022-006800	ROPE, STARTER	1	3.0*880	
12	+	177228-44330	GRIP, STARTER	1		
13		V804-000060	BOLT, TORX 4	4	TB-4*16 10.9	C
14		V804-000010	BOLT, TORX 4	1	TT-4*16 DG 10.9	C
15		X502-000890	LABEL,ECHO	1		D
16		X543-005400	LABEL,MODEL	1	HCS-3210ES	D

Class : Consumable class

A:Fast moving parts B:Semi-fast moving parts C:Slow moving parts D:Order only as needed

GEAR CASE

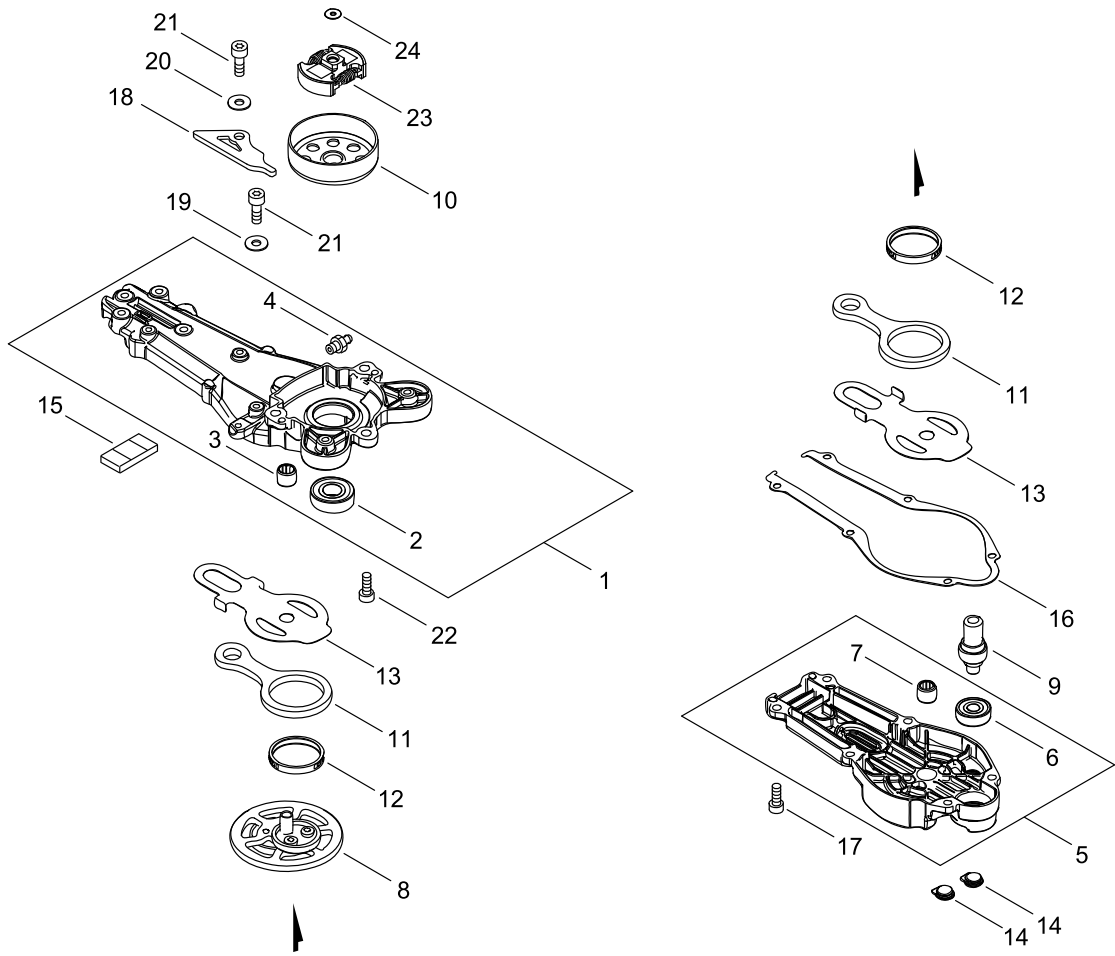

GEAR CASE

Key No.	LV (+)	Parts Number	Parts Description	Qty	Standard	Class
1		P021-041562	GEAR CASE COMP	1		
2	+	900802-06001	BEARING, BALL 6001	1	6001DDU(LLU)	
3	+	V553-000110	BEARING, NEEDLE	1		B
4	+	V187-000080	GREASE NIPPLE	1		C
5		P021-034241	CASE COVER COMP	1		
6	+	900804-00608	BEARING, BALL 608	1	608ZZ	
7	+	V553-000110	BEARING, NEEDLE	1		B
8		V060-000072	GEAR, SPUR	1		C
9		V655-000070	SHAFT, PINION	1		C
10		A556-001430	DRUM, CLUTCH	1		B
11		C532-000200	ROD	2		C
12		V572-000000	BEARING, NEEDLE	2		C
13		C603-000260	PLATE, SIDE	2		C
14		V162-000390	PLUG	2		C
15		V541-000200	SEAL	1		C
16		V110-000190	GASKET, GEAR CASE	1		A
17		V805-000150	BOLT, TORX 5	6	TB-5*16 10.9	C
18		C536-000170	COVER, GEAR CASE	1		C
19		900602-00005	WASHER 5	1	5.3*10*1	
20		V303-000240	COLLAR	1		C
21		V805-000110	BOLT, TORX 5	3	TB-5*6 10.9	C
22		V806-000050	BOLT, TORX 6	3	TB-6*20 12.9	C
23		A056-000700	CLUTCH ASY	1		B
24		610350-12360	WASHER	1		C

Class : Consumable class

A:Fast moving parts B:Semi-fast moving parts C:Slow moving parts D:Order only as needed

CUTTING BLADE

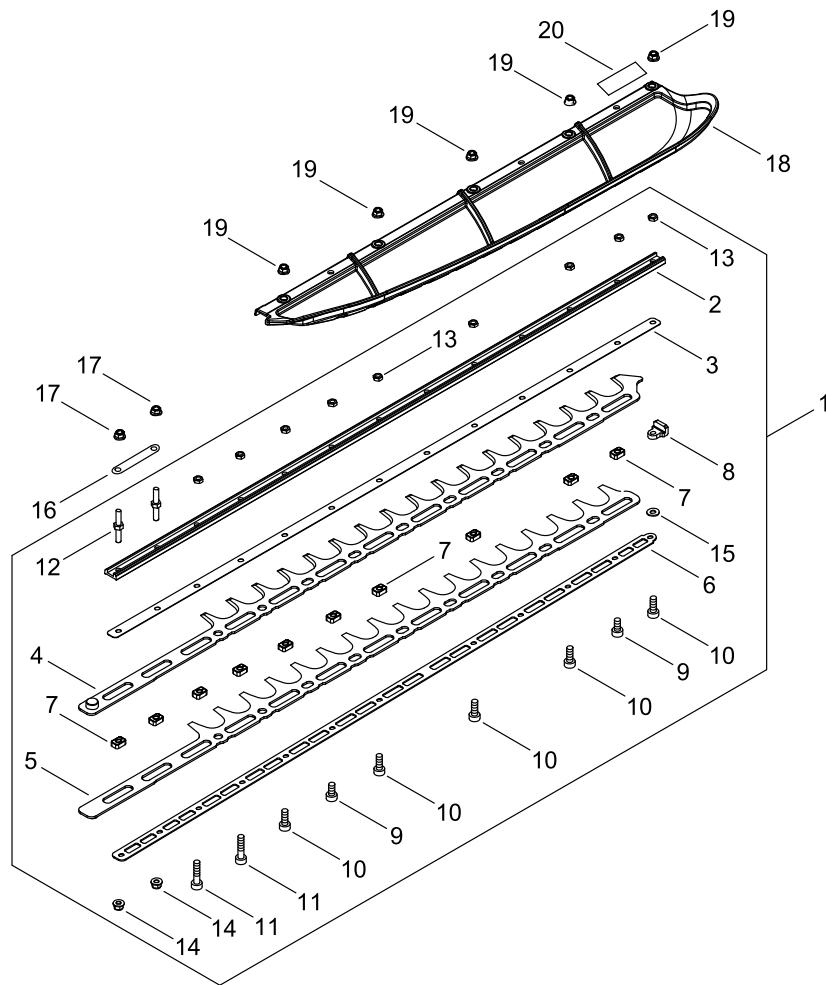

CUTTING BLADE

Key No.	LV (+)	Parts Number	Parts Description	Qty	Standard	Class
1		X041-000690	CUTTER,ASM	1	HCS-3210ES ASSY	B
2	+	X425-001070	SUPPORT,CUTTER	1		B
3	+	X425-001100	SUPPORT,CUTTER	1	HCS-3210ES	B
4	+	X412-000780	CUTTER	1		A
5	+	X412-000790	CUTTER	1		A
6	+	X425-001110	SUPPORT,CUTTER	1	HCS-3210ES	B
7	+	V376-001390	SPACER	10		C
8	+	V376-001380	BLOCK	1		C
9	+	V805-000150	BOLT, TORX 5	2	TB-5*16 10.9	C
10	+	V805-000170	BOLT, TORX 5	5	TB-5*25 10.9	C
11	+	V805-000050	BOLT, TORX 5	2	TB-5*30 10.9	C
12	+	V223-000020	BOLT	2		C
13	+	92022-05000	NUT	9	M5	
14	+	V263-000250	NUT	2	M5	C
15	+	92217-05000	WASHER	1		
16		V150-003700	PLATE,EYE	1		C
17		V263-000250	NUT	2	M5	C
18		C571-000130	PLATE	1	750MM ORANGE	D
19		V263-000250	NUT	5	M5	C
20		X502-001080	LABEL,ECHO	1	22*91	D

Class : Consumable class

A:Fast moving parts B:Semi-fast moving parts C:Slow moving parts D:Order only as needed

MAIN PIPE, HANDLE

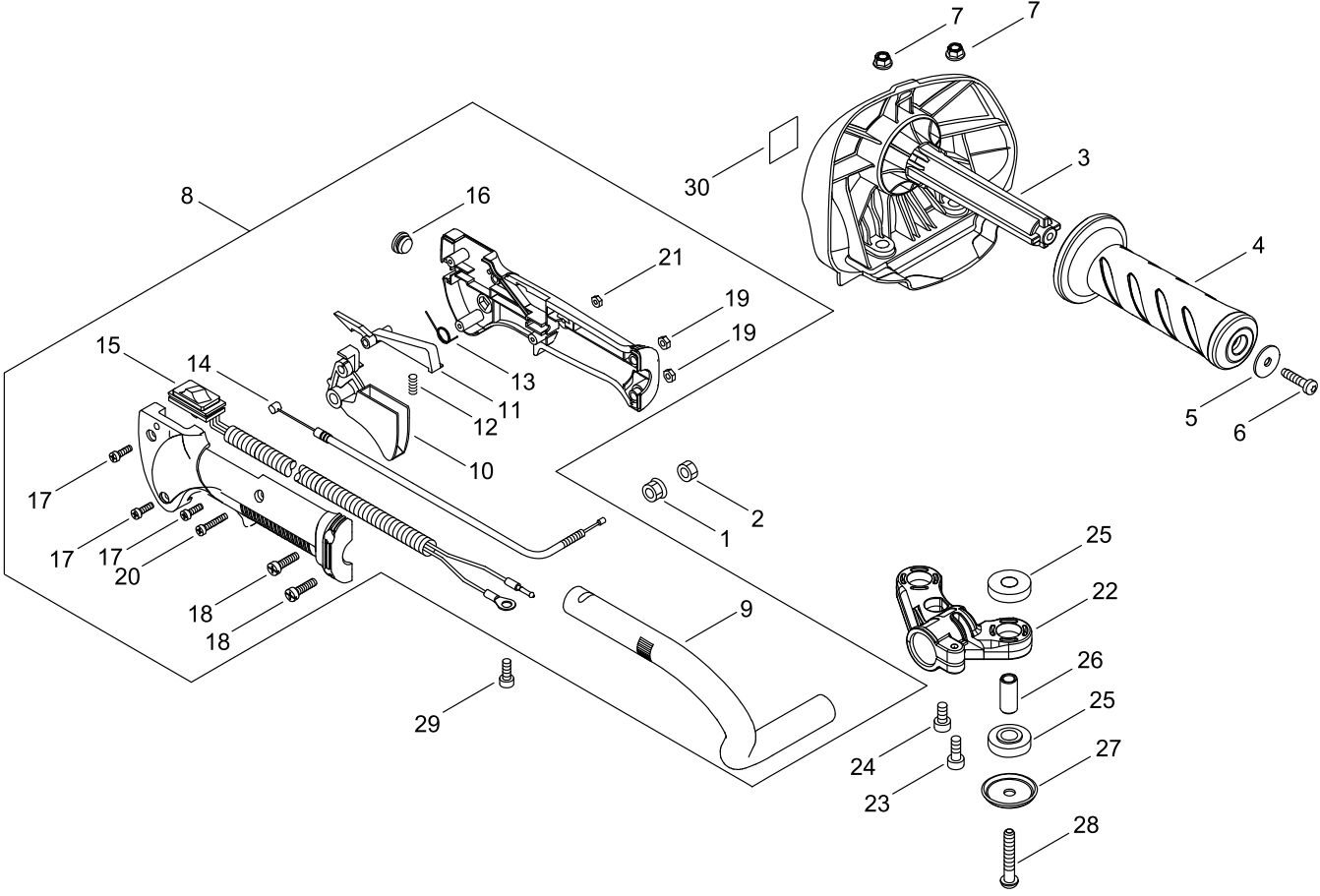

MAIN PIPE, HANDLE

Key No.	LV (+)	Parts Number	Parts Description	Qty	Standard	Class
1		900515-00006	NUT, FLANGE	1	6	
2		900502-00006	NUT	1	6	
3		C400-000851	HANDLE, FRONT	1		C
4		C403-000460	GRIP	1		C
5		V323-000120	WASHER,CIRCULAR 5	1		C
6		V805-000010	BOLT, TORX 5	1	TT-5*20 DG 10.9	C
7		V263-000250	NUT	2	M5	C
8		C041-000800	HANDLE,ASM REAR	1		C
9	+	P022-050860	PIPE	1		
10	+	P022-037380	TRIGGER,THROTTLE	1		
11	+	P022-037390	LOCKOUT,THROTTLE	1		
12	+	V450-001020	COIL SPRING	1		B
13	+	V452-000690	COIL SPRING	1		B
14	+	P022-051060	CABLE,BOWDEN	1		
15	+	P022-051050	SWITCH, ON OFF	1		
16	+	V162-000410	PLUG	1		C
17	+	V252-000360	SCREW TAPPING	3		C
18	+	P022-037460	SCREW	1	M5*22	
19	+	P022-037470	NUT, LOCK	1	M5	
20	+	V252-000370	SCREW	1		C
21	+	V262-000100	NUT	1		C
22		C415-000210	SUPPORTER, HANDLE	1		C
23		V805-000160	BOLT, TORX 5	1	TB-5*20 10.9	C
24		V805-000140	BOLT, TORX 5	1	TB-5*12 10.9	C
25		V420-004390	CUSHION	4		B
26		V354-000310	COLLAR	2	10*6.5*L=22.5	C
27		V304-000230	WASHER,CIRCULAR	2		C
28		V806-000110	BOLT, TORX 6	2	TB-6*35 10.9	C
29		V804-000040	BOLT, TORX 4	1	TB-4*10 10.9	C
30		X505-002030	LABEL,CAUTION	1	37*35	D

Class : Consumable class

A:Fast moving parts B:Semi-fast moving parts C:Slow moving parts D:Order only as needed

ACCESSORIES

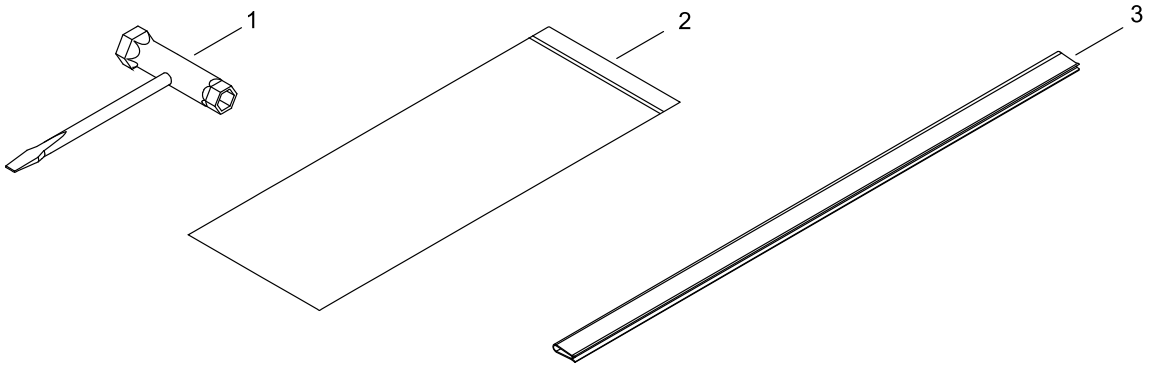

ACCESSORIES

Key No.	LV (+)	Parts Number	Parts Description	Qty	Standard	Class
1		X602-000120	TOOL,WRENCH	1	19-13	D
2		X705-000100	BAG,PACKING	1	140*200*T0.08	
3		X495-000880	SCABBARD,BLADE	1	L805	D

Class : Consumable class

A:Fast moving parts B:Semi-fast moving parts C:Slow moving parts D:Order only as needed

NUMERICAL PARTS INDEX

Part No	Part description	Page	Part No	Part description	Page	Part No	Part description	Page
100014-08960	SPACER, PISTON PIN	2	A172-001990	COVER,FAN	16	P005-003110	PUMP, PRIMER	10
100015-04630	CIRCLIP, PISTON PIN	2	A200-000941	INSULATOR, INTAKE	8	P005-004240	BASE, ASY PRIMER	10
100113-05930	BEARING, NEEDLE	2	A209-000610	PLATE, INSULATOR	8	P021-034241	CASE COVER COMP	18
100142-12330	KEY, WOODRUFF	6	A209-000621	PLATE, INSULATOR	14	P021-037930	PISTON KIT	2
100212-61830	OILSEAL	4	A226-001410	ELEMENT,AIR FILTER	8	P021-041562	GEAR CASE COMP	18
125323-08260	ARM, VALVE	10	A244-000070	PLATE,PREVENT	8	P021-041970	MUFFLER ASY	14
125337-08260	VALVE, INLET NEEDLE	10	A310-000070	SCREEN, ARRESTOR	14	P021-046081	FUEL CAP ASY	12
125338-13930	PIN, METERING ARM	10	A313-001730	GUIDE, EXHAUST	14	P021-046091	CASE,CLEANER	8
125339-42030	SCREW	10	A313-001741	GUIDE,EXH	14	P021-046100	LID,CLEANER ASY	8
125342-52130	COVER, DIAPHRAGM	10	A350-001880	TANK, FUEL	12	P022-006800	ROPE, STARTER	16
125344-13931	SCREW	10	A356-000031	VALVE,CHECK	12	P022-008270	SPRING,DAMPER	16
125344-52130	SCREW	10	A365-000060	CONNECTOR,CAP	12	P022-027980	DRUM, STARTER	16
131205-07321	STRAINER, FUEL	12	A409-001120	ROTOR, MAGNETO	6	P022-037310	PLATE, CAM	16
131911-03460	WASHER	6	A411-001801	COIL, IGNITION	6	P022-037380	TRIGGER,THROTTLE	22
132010-49730	PIPE 3*6*85	12	A425-000000	SPARKPLUG	6	P022-037390	LOCKOUT,THROTTLE	22
132115-44331	GROMMET, FUEL	12	A426-000010	TERMINAL,SPARKPLUG	6	P022-037460	SCREW	22
156114-04920	GROMMET	6	A427-000013	CAP,SPARK PLUG	6	P022-037470	NUT, LOCK	22
177220-42030	SPRING, REWIND	16	A514-000260	PAWL	6	P022-045770	GUIDE, ROPE	16
177228-44330	GRIP, STARTER	16	A556-001430	DRUM, CLUTCH	18	P022-050860	PIPE	22
177236-61830	SCREW	16	C041-000800	HANDLE,ASM REAR	22	P022-051050	SWITCH, ON OFF	22
178070-10860	SPACER	6	C400-000851	HANDLE, FRONT	22	P022-051060	CABLE,BOWDEN	22
610350-12360	WASHER	18	C403-000460	GRIP	22	P022-053050	STARTER,RECOIL	16
890332-52730	LABEL, CHOKE	8	C415-000210	SUPPORTER, HANDLE	22	P100-001510	CRANK CASE SET	4
900502-00006	NUT	22	C532-000200	ROD	18	P100-002061	MUFFLER COVER ASY	14
900515-00006	NUT, FLANGE	22	C536-000170	COVER,GEAR CASE	18	V060-000072	GEAR,SPUR	18
900565-00005	NUT	16	C571-000130	PLATE	20	V100-000720	GASKET,CYL	2
900602-00005	WASHER 5	18	C603-000260	PLATE,SIDE	18	V102-000240	GASKET,CRANKCASE	4
900603-00005	WASHER 5	6	P005-000010	STRAINER	10	V103-001401	GASKET,INTAKE	8
900603-00005	WASHER	14	P005-000100	SCREW, THROTTLEADJUST	10	V103-001410	GASKET,INTAKE	8
900802-06001	BEARING, BALL 6001	18	P005-000190	E-RING	10	V103-001740	GASKET,INTAKE	8
900804-00608	BEARING, BALL 608	18	P005-000200	GASKET, METERING	10	V104-000072	GASKET,EXHAUST	14
900810-36000	BEARING, BALL	4	P005-000250	RETAINER	10	V104-001831	GASKET,EXHAUST	14
91128-05028	BOLT HSH	4	P005-000270	SCREW	10	V107-000190	GASKET,FUEL CAP	12
92022-05000	NUT	20	P005-000280	O-RING	10	V110-000190	GASKET,GEAR CASE	18
92105-06000	NUT, FLANGE	6	P005-000510	DIAPHRAGM, PUMP	10	V137-000001	GROMMET,FUEL	12
92217-05000	WASHER	20	P005-000520	GASKET, PUMP	10	V150-003700	PLATE,EYE	20
A011-001180	CRANKSHAFT,ASY	2	P005-000940	SPRING, METER. LEVER	10	V162-000390	PLUG	18
A021-004670	CARBURETOR, DIAPHRAGM	8	P005-001000	ROLLER, GUIDE	10	V162-000410	PLUG	22
A021-004670	CARBURETOR, DIAPHRAGM	10	P005-001250	RETAINER,PLUG BALL	10	V186-000270	JOINT,PIPE	12
A051-002373	STARTER,RECOIL ASY	16	P005-001260	SCREW,MAINN MIXTURE	10	V187-000080	GREASE NIPPLE	18
A056-000700	CLUTCH ASY	18	P005-001900	SCREW	10	V203-000080	BOLT,5	6
A101-000090	RING,PISTON	2	P005-002050	COVER ASY, ROTOR	10	V203-000170	BOLT,5	2
A130-001960	CYLINDER	2	P005-002200	POST	10	V223-000020	BOLT	20
A160-002470	COVER,CYLINDER	2	P005-002230	DIAPHRAGM ,METERING	10	V252-000360	SCREW TAPPING	22
						V252-000370	SCREW	22

NUMERICAL PARTS INDEX

Part No	Part description	Page	Part No	Part description	Page
V262-000100	NUT	22	V806-000110	BOLT, TORX 6	22
V263-000250	NUT	20	X041-000690	CUTTER,ASM	20
V263-000250	NUT	22	X412-000780	CUTTER	20
V299-000410	KNOB	8	X412-000790	CUTTER	20
V303-000240	COLLAR	18	X425-001070	SUPPORT,CUTTER	20
V304-000230	WASHER,CIRCULAR	22	X425-001100	SUPPORT,CUTTER	20
V323-000120	WASHER,CIRCULAR 5	22	X425-001110	SUPPORT,CUTTER	20
V354-000310	COLLAR	22	X495-000880	SCABBARD,BLADE	24
V376-001380	BLOCK	20	X502-000890	LABEL,ECHO	16
V376-001390	SPACER	20	X502-001080	LABEL,ECHO	20
V420-004390	CUSHION	22	X505-002030	LABEL,CAUTION	22
V420-004490	CUSHION	12	X505-002310	LABEL,CAUTION	14
V450-001020	COIL SPRING	22	X543-005400	LABEL,MODEL	16
V452-000690	COIL SPRING	22	X602-000120	TOOL,WRENCH	24
V452-001370	SPRING,TORSION	6	X705-000100	BAG,PACKING	24
V471-003501	PIPE	12			
V471-003511	PIPE	12			
V485-001220	LEAD	6			
V490-000500	CLIP	12			
V490-001100	CLIP	8			
V541-000200	SEAL	18			
V553-000110	BEARING,NEEDLE	18			
V572-000000	BEARING, NEEDLE	18			
V606-000020	PIN,ENG 8	2			
V655-000070	SHAFT,PINION	18			
V804-000010	BOLT, TORX 4	16			
V804-000030	BOLT, TORX 4	14			
V804-000040	BOLT, TORX 4	22			
V804-000060	BOLT, TORX 4	16			
V804-000100	BOLT, TORX 4	6			
V805-000010	BOLT, TORX 5	22			
V805-000050	BOLT, TORX 5	20			
V805-000100	BOLT, TORX 5	8			
V805-000110	BOLT, TORX 5	18			
V805-000130	BOLT, TORX 5	14			
V805-000140	BOLT, TORX 5	22			
V805-000150	BOLT, TORX 5	2			
V805-000150	BOLT, TORX 5	14			
V805-000150	BOLT, TORX 5	18			
V805-000150	BOLT, TORX 5	20			
V805-000160	BOLT, TORX 5	22			
V805-000170	BOLT, TORX 5	8			
V805-000170	BOLT, TORX 5	20			
V805-000190	BOLT, TORX 5	14			
V806-000050	BOLT, TORX 6	18			