

CS-2511TES_25R

Published:08/24/2016

TABLE OF CONTENTS

CYLINDER, PISTON, CRANKSHAFT.....	1
ENGINE COVER.....	3
MAGNETO.....	5
AIR CLEANER, CARBURETOR.....	7
CARBURETOR.....	9
MUFFLER.....	11
RECOIL STARTER.....	13
HANDLE.....	15
CHAIN BRAKE.....	17
ACCESSORIES.....	19
AUTO-OILER.....	21
GUIDE BAR, CHAIN.....	23
OPTION PARTS.....	25

CYLINDER, PISTON, CRANKSHAFT

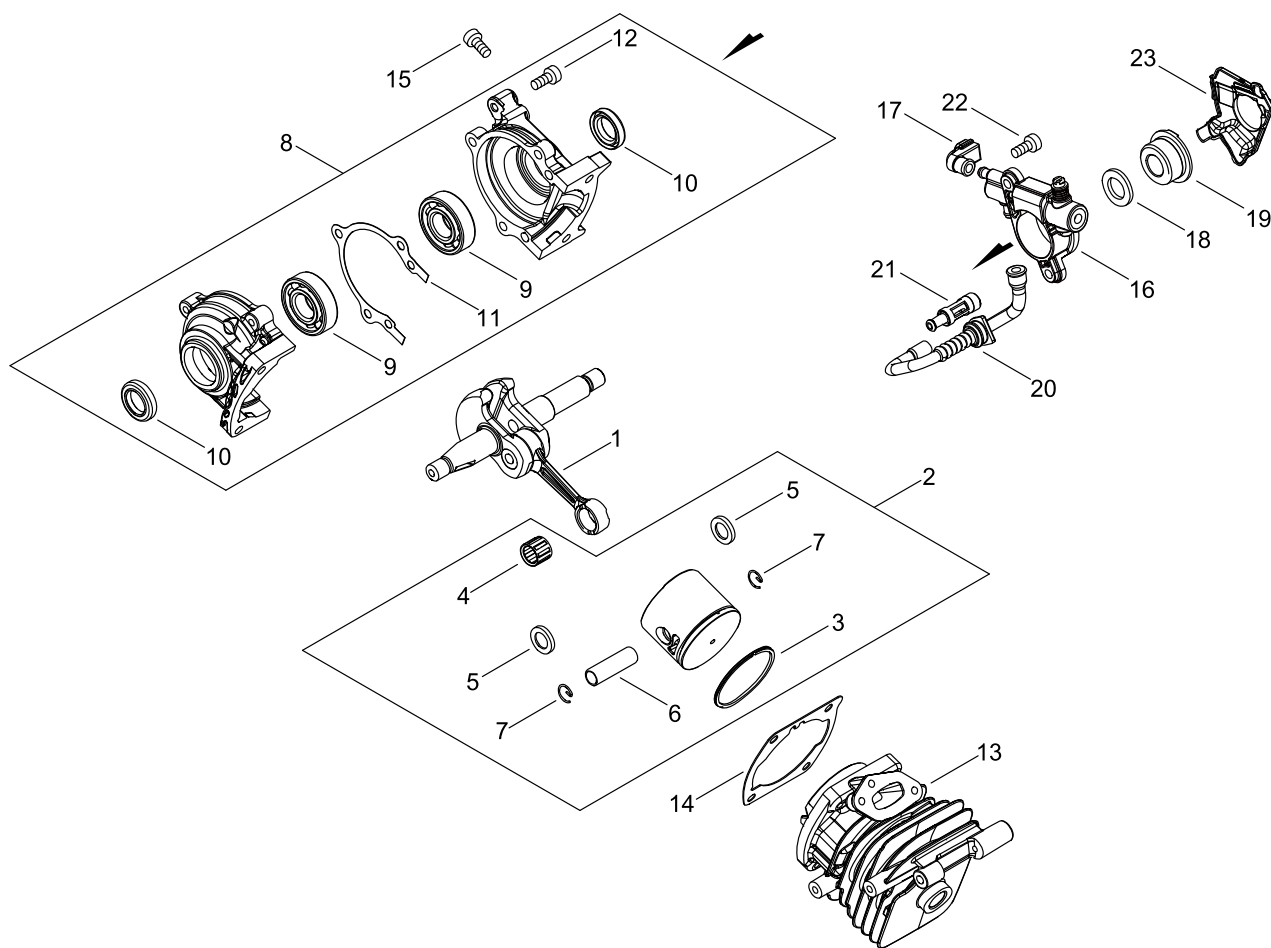

CYLINDER, PISTON, CRANKSHAFT

KEY NO	LV(+)	Part No	Description	Qty	Standard
1		A011-001440	CRANKSHAFT,ASM	1	
2		P021-050120	PISTON KIT	1	
3	+	A101-000700	RING, PISTON	1	35*B1.2*T1.6
4	+	V553-000020	BEARING,NEEDLE 8	1	KBK8X11X8.8X4
5	+	100014-55930	SPACER, PISTON PIN	2	
6	+	V606-000020	PIN,ENG 8	1	5.8*8*25.5
7	+	100015-04630	CIRCLIP, PISTON PIN	2	
8		P021-050130	CRANKCASE SET	1	
9	+	900800-36001	BEARING, BALL 6001	2	6001/C3
10	+	V505-000070	OIL SEAL	2	
11	+	V102-000290	GASKET,CRANKCASE	1	T0.3
12	+	V804-000100	BOLT, TORX 4	3	TB-4*16 12.9
13		P021-051920	CYLINDER	1	
14		V100-000830	GASKET,CYL	1	T0.5
15		V804-000100	BOLT, TORX 4	4	TB-4*16 12.9
16		C022-000210	AUTO-OILER ASSEMBLY	1	
17		V470-002171	PIPE	1	
18		V308-000030	WASHER,CIRCULAR 11	1	10.5*17.4*1.8
19		V652-000230	GEAR,WORM	1	
20		V470-002200	PIPE	1	
21		P021-050140	STRAINER, OIL ASY	1	
22		V804-000050	BOLT, TORX 4	2	TB-4*12 10.9
23		C236-000150	COVER,OILER	1	

ENGINE COVER

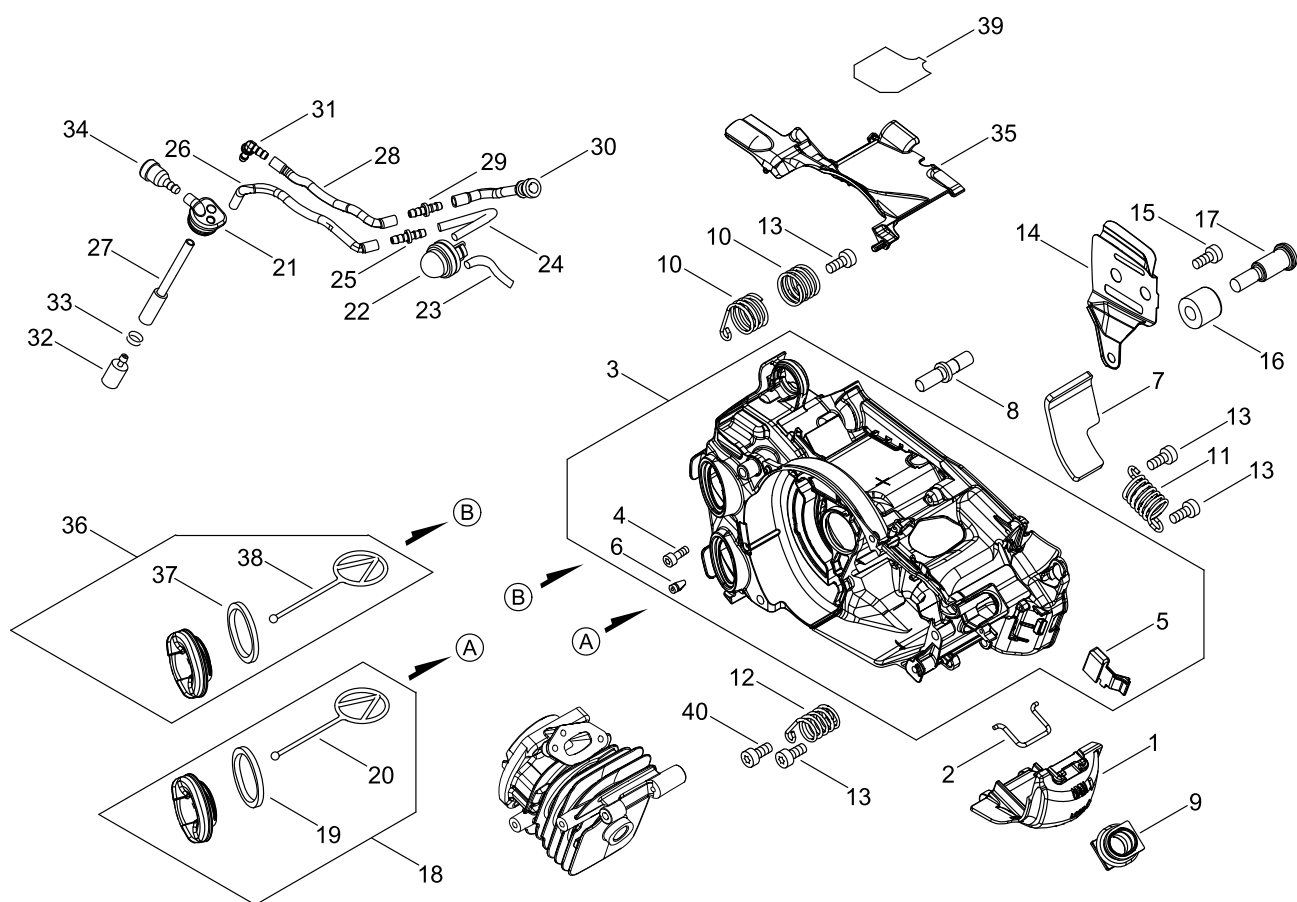

ENGINE COVER

KEY NO	LV(+)	Part No	Description	Qty	Standard
1		A429-000200	COVER,CAP	1	
2		C649-000440	HOOK	1	
3		P021-051910	ENGINE COVER ASY	1	
4	+	V804-000100	BOLT, TORX 4	3	TB-4*16 12.9
5	+	A219-000071	SHUTTER, AIR	1	
6	+	436114-13930	VALVE, CHECK	1	
7		V341-000200	WASHER,SQUARE	1	
8		V225-000262	BOLT,STUD 8	1	
9		A239-000110	PIPE, INTAKE	1	
10		V450-002050	SPRING,COMPRESSION	2	
11		V450-002060	SPRING,COMPRESSION	1	
12		V450-002070	SPRING,COMPRESSION	1	
13		V804-000000	BOLT, TORX 4	4	TT-4*12 DG 10.9
14		C305-000490	PLATE,SPROCKET GUARD	1	T0.3
15		V203-002280	BOLT,5	1	
16		C310-000140	CATCHER, CHAIN	1	
17		V203-002260	BOLT,5	1	
18		A033-000390	CAP,FUEL	1	
19	+	V107-000180	GASKET,FUEL CAP	1	
20	+	A365-000050	CONNECTOR,CAP	1	
21		V137-000140	GROMMET,FUEL	1	
22		123181-39130	PUMP, PRIMER	1	
23		V470-002180	PIPE	1	
24		V471-004870	PIPE	1	3*5*58L
25		V186-000020	JOINT,PIPE	1	
26		V471-003660	PIPE	1	
27		V470-002210	PIPE	1	
28		V471-003820	PIPE	1	3*5*95
29		V186-000510	JOINT,PIPE	1	
30		V470-002190	PIPE	1	
31		V186-000530	JOINT,PIPE	1	
32		A369-000420	STRAINER, FUEL	1	ES-16499
33		V490-000500	CLIP	1	
34		131300-56431	VENT ASSEMBLY, FUEL	1	
35		A127-000450	COVER,DUST	1	
36		A033-000410	CAP,FUEL	1	
37	+	V107-000180	GASKET,FUEL CAP	1	
38	+	A365-000050	CONNECTOR,CAP	1	
39		X505-008600	LABEL,CAUTION	1	CE(112DB)
40		V804-000010	BOLT, TORX 4	1	TT-4*16 DG 10.9

MAGNETO

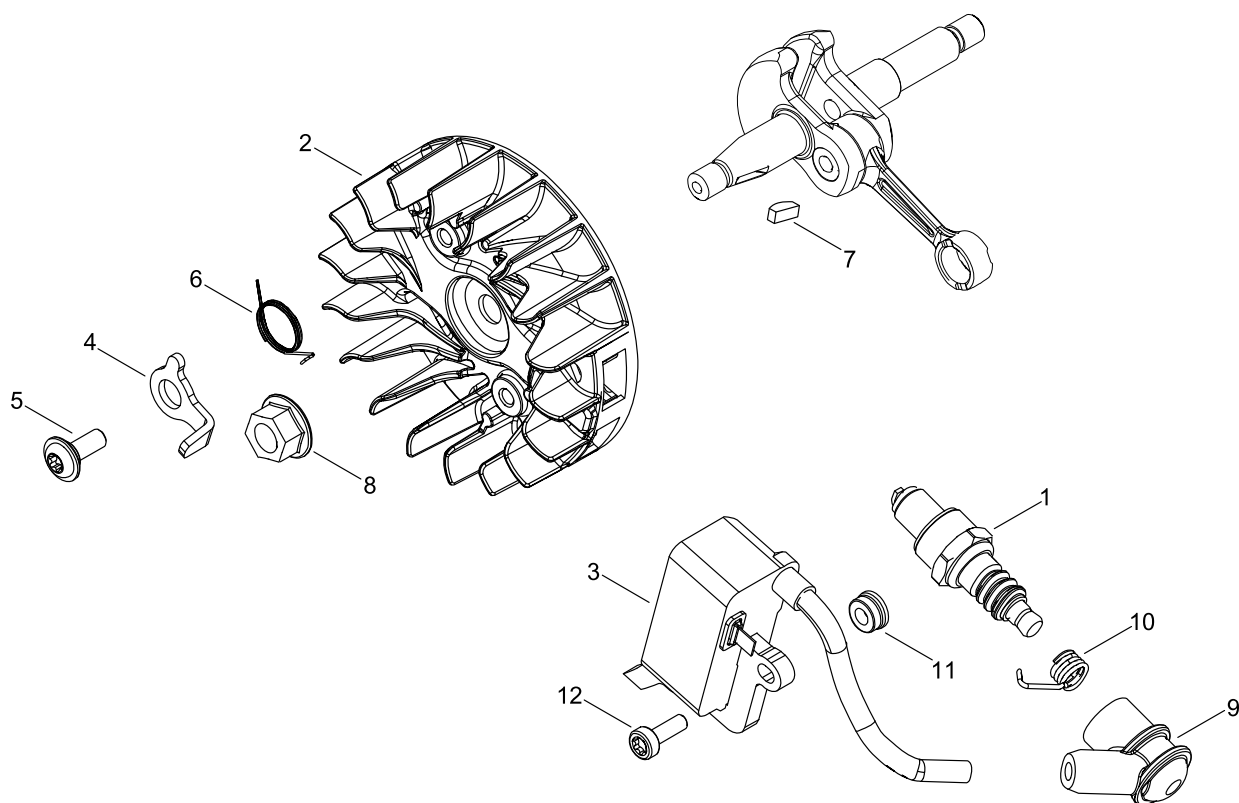

MAGNETO

KEY NO	LV(+)	Part No	Description	Qty	Standard
1		A425-000060	SPARKPLUG	1	CMR7H
2		A409-001300	ROTOR, MAGNETO	1	
3		P021-050160	COIL, IGNITION	1	
4		A514-000300	PAWL	2	
5		V203-002250	BOLT,5	2	
6		V452-000030	SPRING,TORSION	2	
7		100142-12330	KEY, WOODRUFF	1	
8		V265-000140	NUT	1	
9		A427-000190	CAP,SPARK PLUG	1	
10		A426-000010	TERMINAL,SPARKPLUG	1	
11		V352-000300	COLLAR,4	2	4.5*8.3*4.6L
12		V804-000060	BOLT, TORX 4	2	TB-4*16 10.9

AIR CLEANER, CARBURETOR

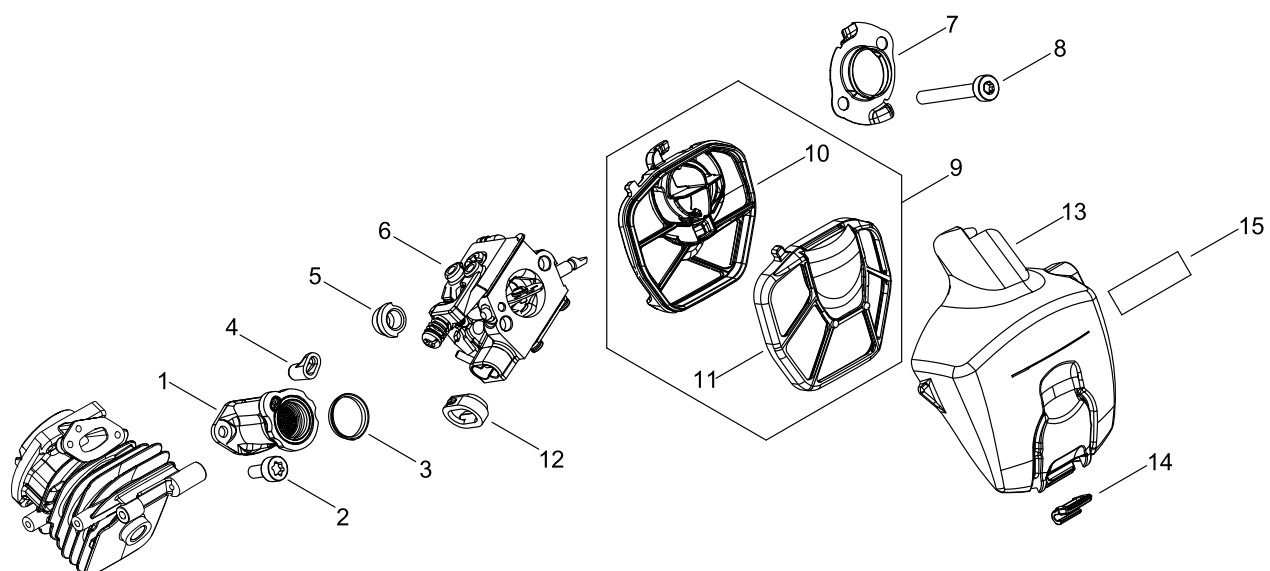

AIR CLEANER, CARBURETOR

KEY NO	LV(+)	Part No	Description	Qty	Standard
1		A202-000290	BELLOWS, INTAKE	1	
2		V804-000040	BOLT, TORX 4	2	TB-4*10 10.9
3		V358-000220	COLLAR,14	1	14*16*2.5
4		V351-000030	COLLAR,3	1	
5		V162-000770	PLUG	2	
6		A021-004520	CARBURETOR, DIAPHRAGM	1	WT-1153
7		A204-000250	ELBOW, CARBURETOR	1	T:0.5
8		V805-000070	BOLT, TORX 5	2	TB-5*40 10.9
9		A226-002140	ELEMENT, AIR FILTER	1	
10	+	A226-002120	ELEMENT, AIR FILTER	1	
11	+	A226-002130	ELEMENT, AIR FILTER	1	
12		V131-000220	GROMMET,NEEDLE	1	
13		A232-001841	LID,CLEANER	1	
14		A235-000410	KNOB,CLEANER LID	1	
15		X503-014140	LABEL,MODEL	1	

CARBURETOR

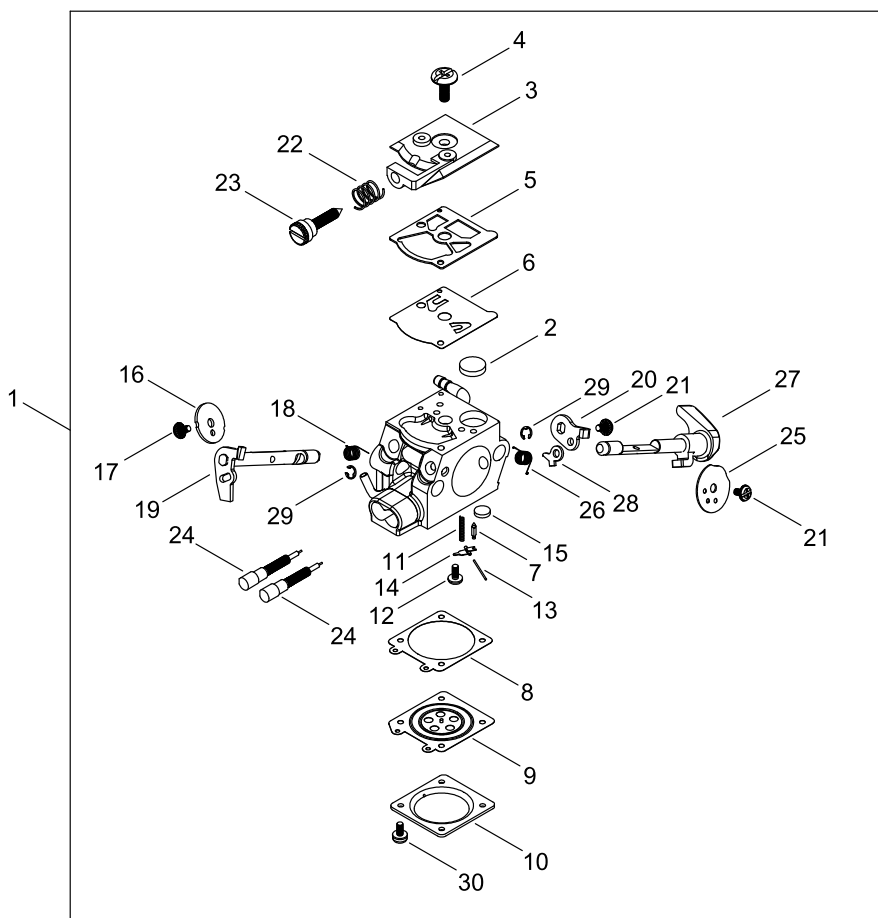

CARBURETOR

KEY NO	LV(+)	Part No	Description	Qty	Standard
1		A021-004520	CARBURETOR, DIAPHRAGM	1	WT-1153
2	+	123126-10631	SCREEN, INLET	1	
3	+	123124-02960	COVER, FUEL PUMP	1	
4	+	123110-03930	SCREW, PUMP COVER	1	
5	+	123125-15030	GASKET, FUEL PUMP	1	
6	+	123112-15030	DIAPHRAGM, FUEL PUMP	1	
7	+	123137-19830	VALVE, INLET NEEDLE	1	
8	+	123140-27230	GASKET,M. DIAPHRAGM	1	
9	+	P003-001850	DIAPHRAGM, METERING	1	
10	+	123142-03930	COVER, M. DIAPHRAGM	1	
11	+	123122-39830	SPRING, METER. LEVER	1	
12	+	123139-03930	SCREW, M. LEVER PIN	1	
13	+	123138-03930	PIN, METERING LEVER	1	
14	+	123123-03930	LEVER, METERING	1	
15	+	123146-10631	PLUG, WELCH	1	
16	+	P003-005750	VALVE, THROTTLE	1	
17	+	P003-002380	SCREW	1	
18	+	123113-37530	SPRING, THROTTLE RTN	1	
19	+	P003-001300	SHAFT, THROTTLE	1	
20	+	P003-000380	THROTTLE, LEVER	1	
21	+	123114-38830	SCREW	2	
22	+	123133-04260	SPRING, IDLE ADJUST	1	
23	+	123134-04260	SCREW, IDLE ADJUST	1	
24	+	P003-004190	NEEDLE	2	
25	+	P003-000410	VALVE CHOKE	1	
26	+	P003-004780	SPRING	1	
27	+	P003-005760	SHAFT-CHOKE	1	
28	+	P003-001510	LEVER-FAST IDLE	1	
29	+	123127-15030	RING	2	
30	+	123130-02960	SCREW	4	

MUFFLER

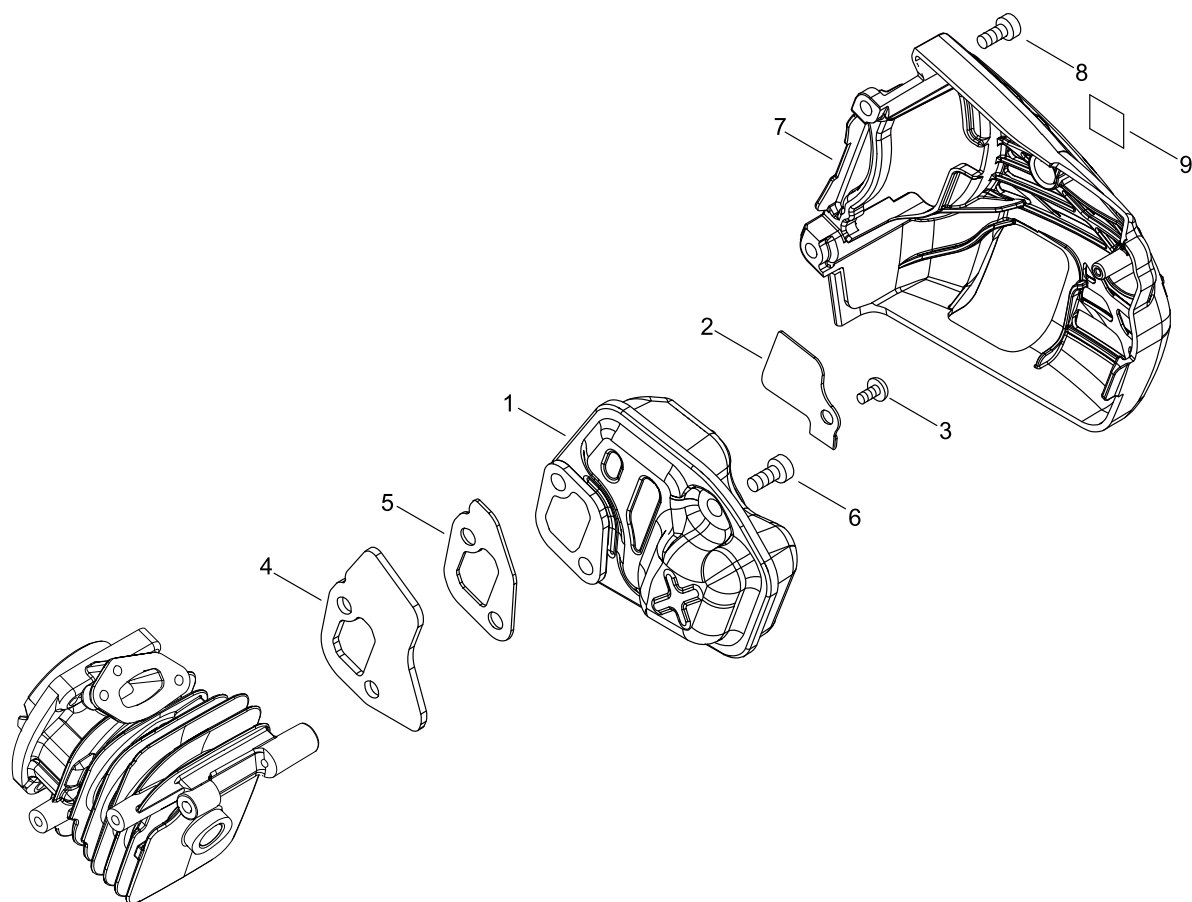

MUFFLER

KEY NO	LV(+)	Part No	Description	Qty	Standard
1		A030-000860	MUFFLER ASY	1	
2		A310-000490	SCREEN, ARRESTOR	1	
3		900216-04006	SCREW	1	4*6
4		A312-000090	PLATE, EXHUST	1	
5		V104-002290	GASKET,EXHAUST	1	
6		V805-000150	BOLT, TORX 5	3	TB-5*16 10.9
7		A320-001210	COVER,MUFFLER	1	
8		V804-000010	BOLT, TORX 4	2	TT-4*16 DG 10.9
9		X505-007710	LABEL,CAUTION	1	

RECOIL STARTER

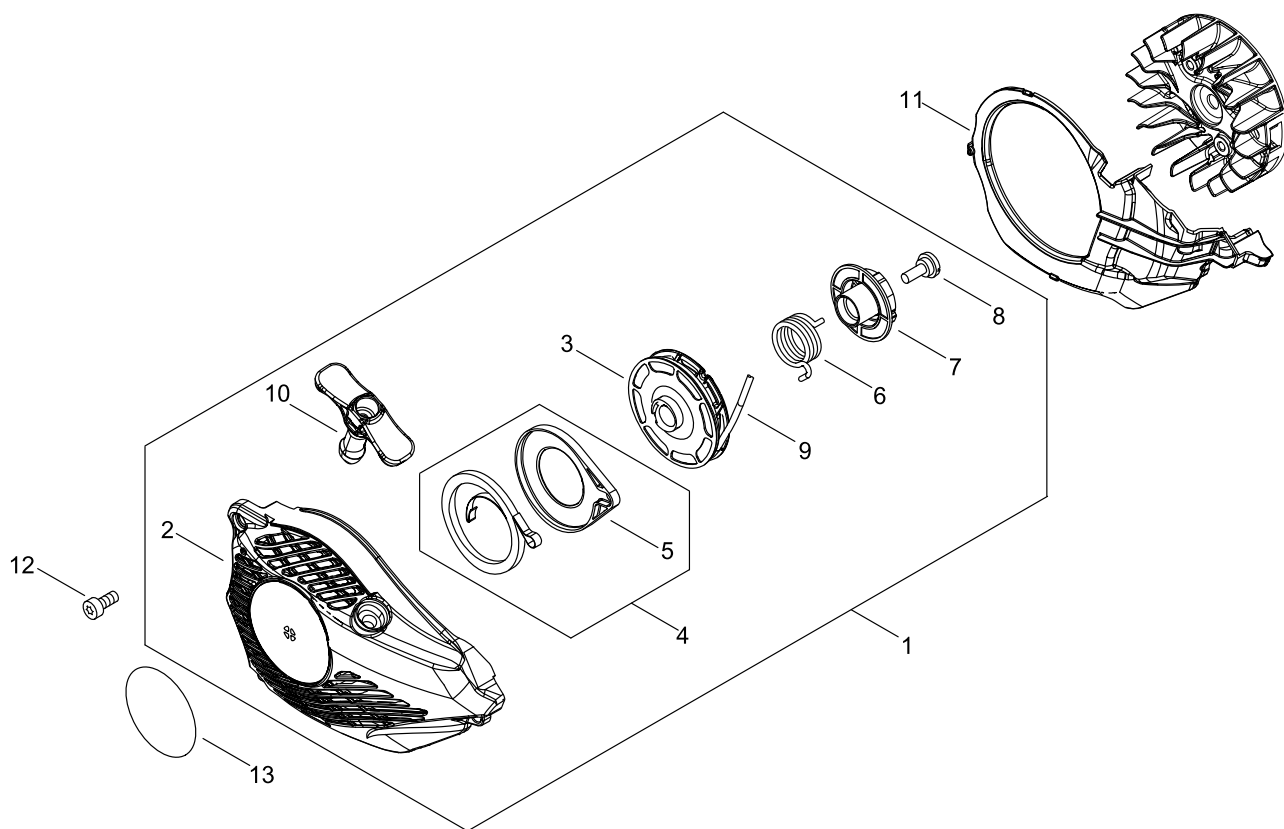

RECOIL STARTER

KEY NO	LV(+)	Part No	Description	Qty	Standard
1		A051-003131	STARTER,RECOIL ASY	1	
2	+	P022-045300	CASE,STARTER ASY	1	
3	+	P022-040050	DRUM	1	
4	+	P022-040060	SPRING KIT, REWIND	1	
5	++	P022-040070	SPRING CASE	1	
6	+	P022-036670	SPRING,DAMPER	1	
7	+	P022-040080	PLATE, CAM	1	
8	+	177236-61830	SCREW	1	
9	+	P022-040090	ROPE, STARTER	1	3*700
10	+	P022-040100	GRIP, STARTER	1	
11		A172-003200	COVER,FAN	1	
12		V804-000060	BOLT, TORX 4	3	TB-4*16 10.9
13		X502-001030	LABEL,ECHO	1	ECHO

HANDLE

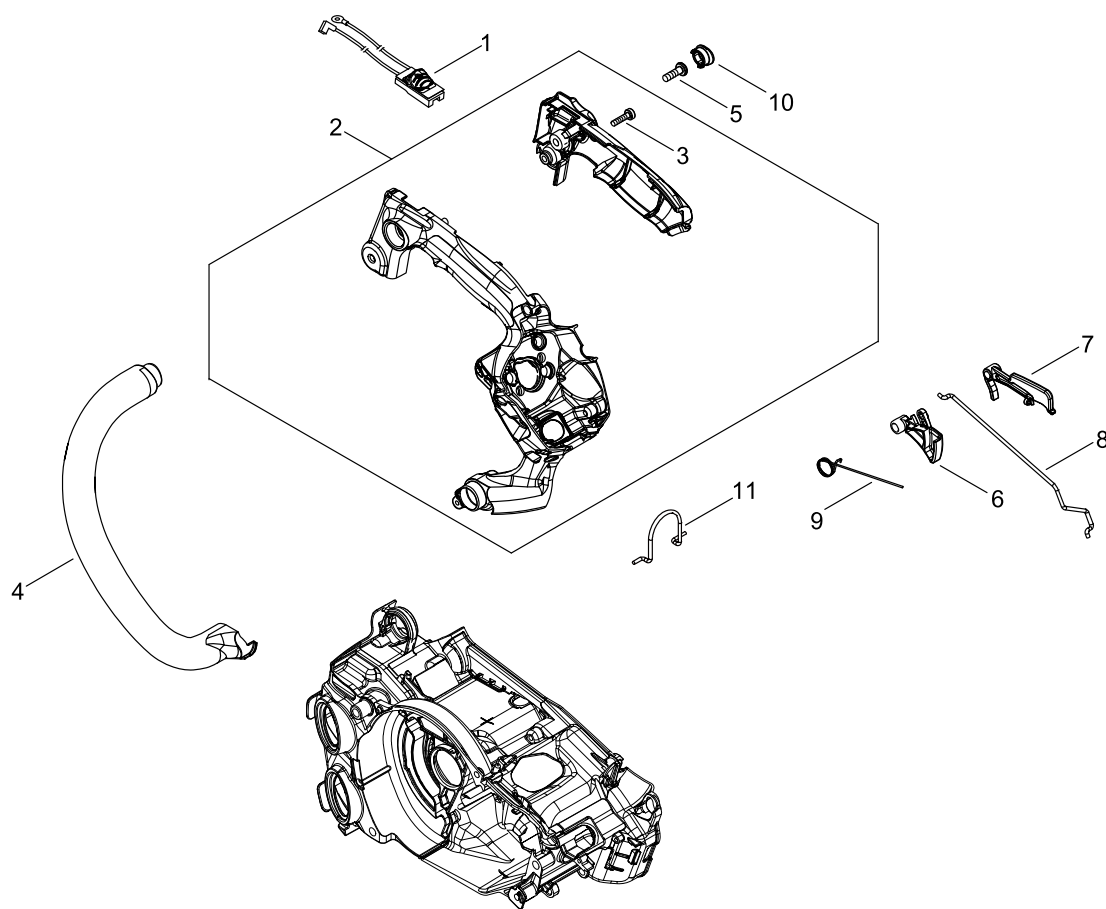

HANDLE

KEY NO	LV(+)	Part No	Description	Qty	Standard
1		A440-002740	SWITCH,ON OFF	1	
2		P021-050171	HANDLE SET, REAR	1	
3	+	V804-000010	BOLT, TORX 4	1	TT-4*16 DG 10.9
4		C400-001550	HANDLE, FRONT	1	
5		V805-000000	BOLT, TORX 5	1	TT-5*16 DG 10.9
6		C450-000950	CONTROL, THROTTLE	1	
7		C460-000590	LOCKOUT, THROTTLE	1	
8		C454-000540	ROD, THROTTLE	1	
9		V452-001650	SPRING,TORSION	1	
10		V162-000760	PLUG	1	
11		C646-000132	RING,HARNESS	1	

CHAIN BRAKE

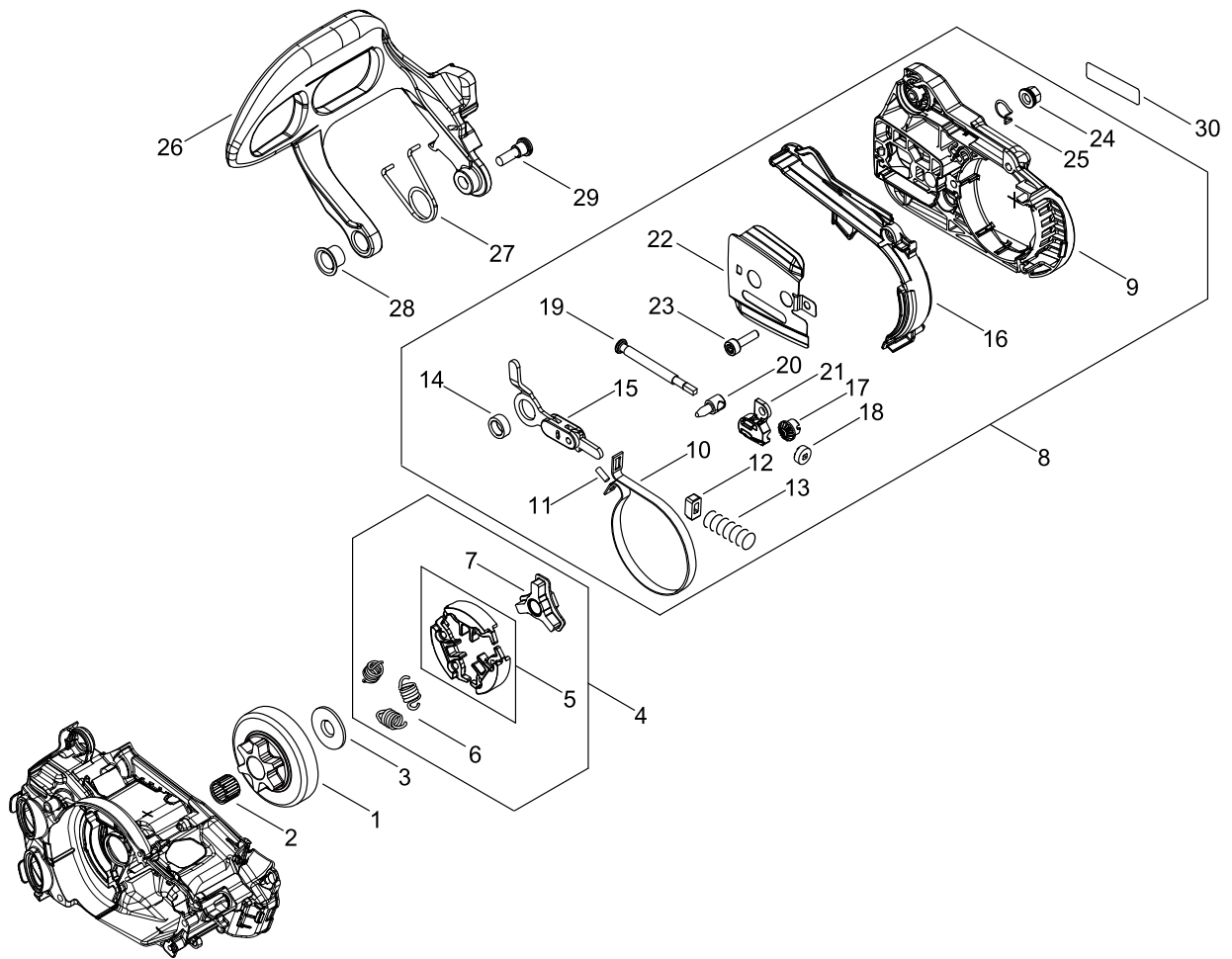

CHAIN BRAKE

KEY NO	LV(+)	Part No	Description	Qty	Standard
1		A556-001720	DRUM, CLUTCH	1	3/8
2		V555-000190	BEARING,NEEDLE 10	1	10*13*9.8
3		A551-000170	PLATE, CLUTCH	1	
4		A056-000800	CLUTCH ASY	1	
5	+	P021-050190	CLUTCH SHOE SET	1	
6	+	A566-000290	SPRING, CLUTCH	3	
7	+	A552-000430	HUB, CLUTCH	1	
8		P021-050202	GUARD, SPROCKET ASY	1	
9	+	C300-001112	GUARD, SPROCKET	1	
10	+	C328-000330	BAND, BRAKE	1	
11	+	93050-30080	ROLLER	1	
12	+	V376-000450	SPACER	1	
13	+	V450-002080	SPRING,COMPRESSION	1	
14	+	V355-000860	COLLAR,8	1	
15	+	C334-000340	CONNECTOR, BRAKE	1	
16	+	C345-000640	COVER,BRAKE	1	
17	+	V651-001060	GEAR,BEVEL	1	
18	+	V651-000011	GEAR,BEVEL	1	
19	+	V203-000041	BOLT,5	1	
20	+	C309-000110	TENSIONER,CHAIN	1	
21	+	V355-000840	COLLAR,8	1	
22	+	C305-000500	PLATE,SPROCKET GUARD	1	T0.3
23	+	V804-000000	BOLT, TORX 4	3	TT-4*12 DG 10.9
24	+	V265-000550	NUT,8	1	
25	+	C649-000420	HOOK	1	
26		C320-000510	LEVER, BRAKE	1	
27		V452-001660	SPRING,TORSION	1	
28		V356-000780	COLLAR,10	1	
29		V203-002270	BOLT,5	1	
30		X502-000340	LABEL,ECHO	1	ECHO(WHITE)

ACCESSORIES

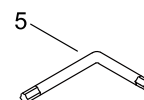
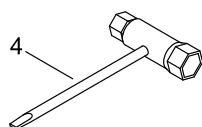
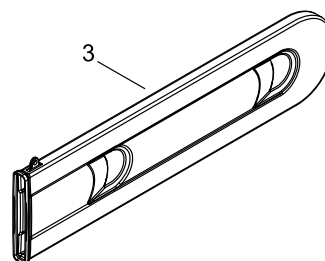
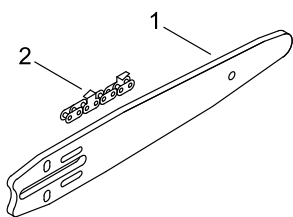

ACCESSORIES

KEY NO	LV(+)	Part No	Description	Qty	Standard
1		X121-000003	BAR,GUIDE 25	1	C25S91-40SL-ET
2		X221-000100	CHAIN,SAW	1	91PX-40E
3		X490-000840	SCABBARD,CHAIN	1	
4		X602-000160	PLUG WRENCH	1	
5		X605-000190	TOOL,L WRENCH	1	T27 120*80

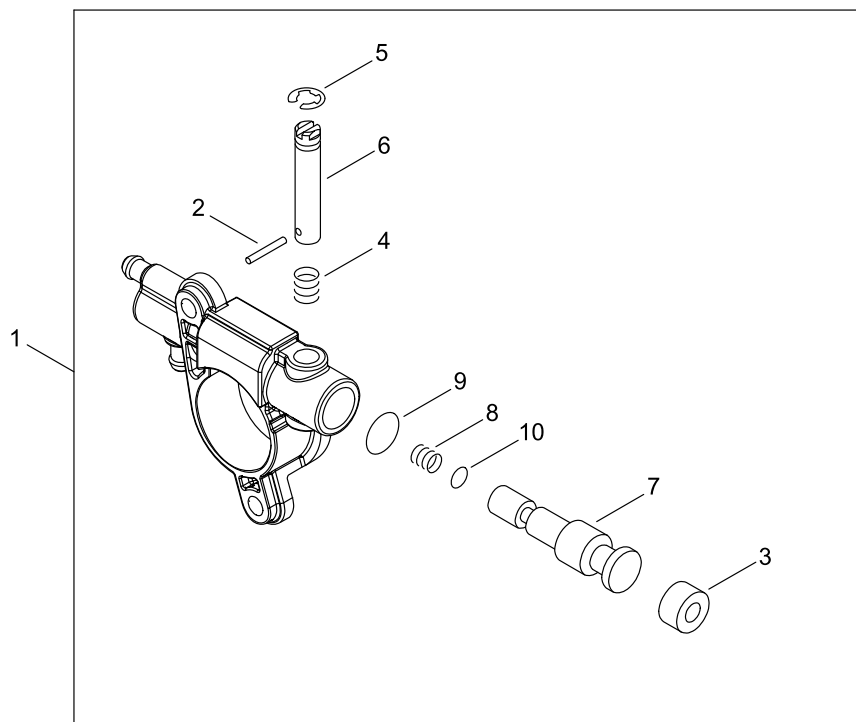

AUTO-OILER



AUTO-OILER

KEY NO	LV(+)	Part No	Description	Qty	Standard
1		C022-000210	AUTO-OILER ASSEMBLY	1	
2	+	P003-002180	PIN, SPRING	1	
3	+	437062-38330	CAP, OIL PUMP	1	
4	+	437015-37330	SPRING	1	
5	+	123127-15030	RING	1	
6	+	P003-005430	NEEDLE-ADJ	1	
7	+	P003-005770	SHAFT ASY-PLUNGER	1	
8	+	P003-005780	SPRING	1	
9	+	P003-005420	WASHER	1	
10	+	P003-005790	WASHER	1	

GUIDE BAR, CHAIN

Pitch ピッチ	Gauge ゲージ	Length 長さ	Guide Bar ガイドバー		Saw Chain ソーチェン		Hard Nose ハード ノーズ 	Sprocket Nose スプロケット ノーズ 
			Key	Type 形式	Key	Type 形式		
1/4 6.35 (inch) (mm)	0.050 1.27 (inch) (mm)	20	A1	C20H25-52CL- ED	A2	25AP-52E	●	
1/4 6.35	0.050 1.27	25	B1	C25H25-60CL- ET	B2	25AP-60E	●	
1/4 6.35	0.050 1.27	25	C1	C25H25-60CLD ED	C2	25AP-60E	●	
3/8 9.53	0.050 1.27	20	D1	C20S91-35SA- ET	D2	91PX-35E		●
3/8 9.53	0.050 1.27	25	E1	C25S91-40SL- ET	E2	91PX-40E		●
3/8 9.53	0.050 1.27	30	F1	C30S91-47ML- ET	F2	91PX-47E		●

GUIDE BAR, CHAIN

KEY NO	LV(+)	Part No	Description	Qty	Standard
A1		X100-000060	BAR,GUIDE 20	1	C20H25-52CL-ED
A2		X200-000000	CHAIN,SAW	1	25AP-52E
B1		X101-000011	BAR,GUIDE 25	1	C25H25-60CL-ET
B2		431610-10030	CHAIN, SAW	1	25AP-60E
C1		X101-000200	BAR,GUIDE 25	1	C25H25-60CLD ED
C2		431610-10030	CHAIN, SAW	1	25AP-60E
D1		X120-000021	BAR,GUIDE 20	1	C20S91-35SA-ET
D2		X220-000020	CHAIN,SAW	1	91PX-35E
E1		X121-000003	BAR,GUIDE 25	1	C25S91-40SL-ET
E2		X221-000100	CHAIN,SAW	1	91PX-40E
F1		X122-000073	BAR,GUIDE 30	1	C30S91-47ML-ET
F2		X222-000140	CHAIN,SAW	1	91PX-47E

OPTION PARTS

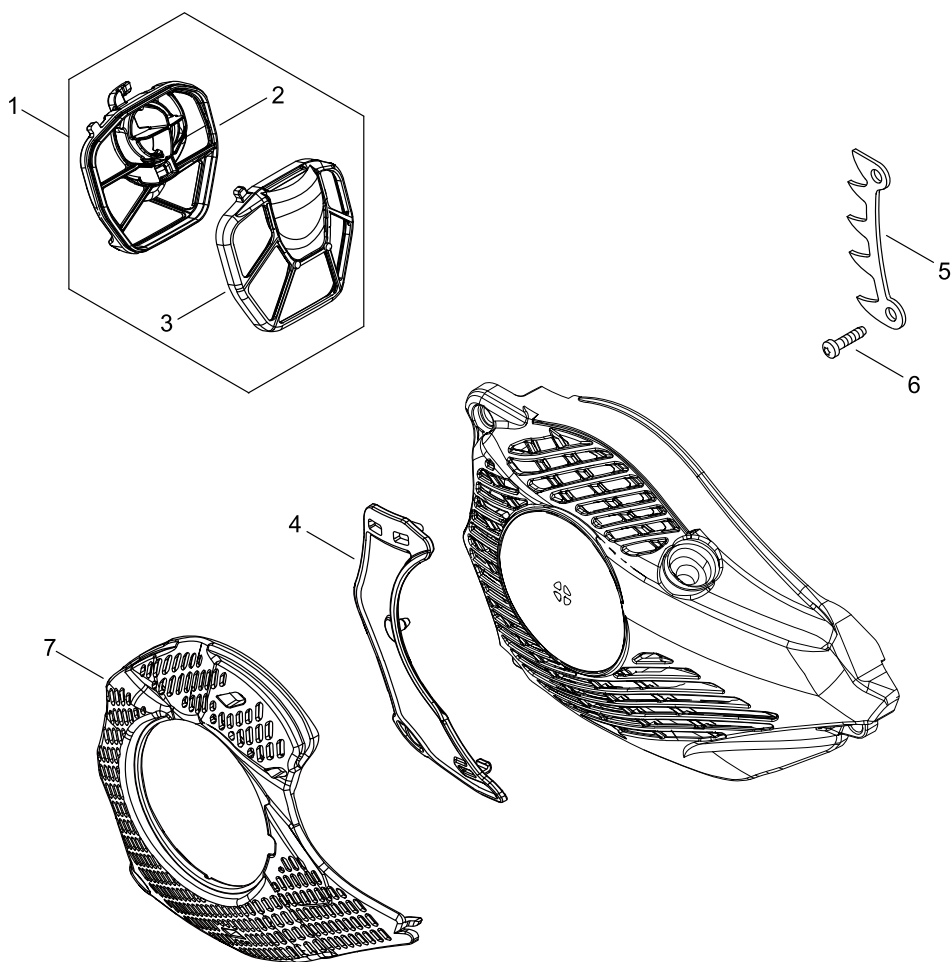

OPTION PARTS

KEY NO	LV(+)	Part No	Description	Qty	Standard
1		A226-001991	ELEMENT, AIR FILTER	1	
2	+	A226-001970	ELEMENT, AIR FILTER	1	
3	+	A226-001981	ELEMENT, AIR FILTER	1	
4		C418-000150	SHIELD, SNOW	1	
5		C304-000000	SPIKE	1	
6		V805-000240	BOLT, TORX 5	2	TT-5*12 DG 10.9
7		A127-000480	COVER,DUST	1	

NUMERICAL PARTS INDEX

Part No	Part description	Page	Part No	Part description	Page	Part No	Part description	Page
100014-5-5930	SPACER, PISTON PIN	2	131300-5-6431	VENT ASSEMBLY, FUEL	4	A226-00-1970	ELEMENT, AIR FILTER	26
100015-0-4630	CIRCLIP, PISTON PIN	2	177236-6-1830	SCREW	14	A226-00-1981	ELEMENT, AIR FILTER	26
100142-1-2330	KEY, WOODRUFF	6	431610-1-0030	CHAIN, SAW	24	A226-00-1991	ELEMENT, AIR FILTER	26
123110-0-3930	SCREW, PUMP COVER	10	436114-1-3930	VALVE, CHECK	4	A226-00-2120	ELEMENT, AIR FILTER	8
123112-1-5030	DIAPHRAGM, FUEL PUMP	10	437015-3-7330	SPRING	22	A226-00-2130	ELEMENT, AIR FILTER	8
123113-3-7530	SPRING, THROTTLE RTN	10	437062-3-8330	CAP, OIL PUMP	22	A226-00-2140	ELEMENT, AIR FILTER	8
123114-3-8830	SCREW	10	900216-0-4006	SCREW	12	A232-00-1841	LID,CLEANER	8
123122-3-9830	SPRING, METER. LEVER	10	900800-3-6001	BEARING, BALL 6001	2	A235-00-0410	KNOB,CLEANER LID	8
123123-0-3930	LEVER, METERING	10	93050-30-080	ROLLER	18	A239-00-0110	PIPE, INTAKE	4
123124-0-2960	COVER, FUEL PUMP	10	A011-00-1440	CRANKSHAFT,ASM	2	A310-00-0490	SCREEN, ARRESTOR	12
123125-1-5030	GASKET, FUEL PUMP	10	A021-00-4520	CARBURETOR, DIAPHRAGM	8	A312-00-0090	PLATE, EXHUST	12
123126-1-0631	SCREEN, INLET	10	A021-00-4520	CARBURETOR, DIAPHRAGM	10	A320-00-1210	COVER,MUFFLER	12
123127-1-5030	RING	10	A030-00-0860	MUFFLER ASY	12	A365-00-0050	CONNECTOR,CAP	4
123127-1-5030	RING	22	A033-00-0390	CAP,FUEL	4	A369-00-0420	STRAINER, FUEL	4
123130-0-2960	SCREW	10	A033-00-0410	CAP,FUEL	4	A409-00-1300	ROTOR, MAGNETO	6
123133-0-4260	SPRING, IDLE ADJUST	10	A051-00-3131	STARTER,RECOIL ASY	14	A425-00-0060	SPARKPLUG	6
123134-0-4260	SCREW, IDLE ADJUST	10	A056-00-0800	CLUTCH ASY	18	A426-00-0010	TERMINAL, SPARKPLUG	6
123137-1-9830	VALVE, INLET NEEDLE	10	A101-00-0700	RING, PISTON	2	A427-00-0190	CAP,SPARK PLUG	6
123138-0-3930	PIN, METERING LEVER	10	A127-00-0450	COVER,DUST	4	A429-00-0200	COVER,CAP	4
123139-0-3930	SCREW, M. LEVER PIN	10	A127-00-0480	COVER,DUST	26	A440-00-2740	SWITCH,ON OFF	16
123140-2-7230	GASKET,M. DIAPHRAGM	10	A172-00-3200	COVER,FAN	14	A514-00-0300	PAWL	6
123142-0-3930	COVER, M. DIAPHRAGM	10	A202-00-0290	BELLOWS, INTAKE	8	A551-00-0170	PLATE, CLUTCH	18
123146-1-0631	PLUG, WELCH	10	A204-00-0250	ELBOW, CARBURETOR	8	A552-00-0430	HUB, CLUTCH	18
123181-3-9130	PUMP, PRIMER	4	A219-00-0071	SHUTTER, AIR	4	A556-00-1720	DRUM, CLUTCH	18

NUMERICAL PARTS INDEX

Part No	Part description	Page	Part No	Part description	Page	Part No	Part description	Page
A566-00-0290	SPRING, CLUTCH	18	P003-00-1300	SHAFT, THROTTLE	10	P022-04-0050	DRUM	14
C022-00-0210	AUTO-OILER ASSEMBLY	2	P003-00-1510	LEVER-FAST IDLE	10	P022-04-0060	SPRING KIT, REWIND	14
C022-00-0210	AUTO-OILER ASSEMBLY	22	P003-00-1850	DIAPHRAGM, METERING	10	P022-04-0070	SPRING CASE	14
C236-00-0150	COVER,OILER	2	P003-00-2180	PIN, SPRING	22	P022-04-0080	PLATE, CAM	14
C300-00-1112	GUARD, SPROCKET	18	P003-00-2380	SCREW	10	P022-04-0090	ROPE, STARTER	14
C304-00-0000	SPIKE	26	P003-00-4190	NEEDLE	10	P022-04-0100	GRIP, STARTER	14
C305-00-0490	PLATE,SPROCKET GUARD	4	P003-00-4780	SPRING	10	P022-04-5300	CASE,STARTER ASY	14
C305-00-0500	PLATE,SPROCKET GUARD	18	P003-00-5420	WASHER	22	V100-00-0830	GASKET,CYL	2
C309-00-0110	TENSIONER,CHAIN	18	P003-00-5430	NEEDLE-ADJ	22	V102-00-0290	GASKET, CRANKCASE	2
C310-00-0140	CATCHER, CHAIN	4	P003-00-5750	VALVE, THROTTLE	10	V104-00-2290	GASKET,EXHAUST	12
C320-00-0510	LEVER, BRAKE	18	P003-00-5760	SHAFT-CHOKE	10	V107-00-0180	GASKET,FUEL CAP	4
C328-00-0330	BAND, BRAKE	18	P003-00-5770	SHAFT ASY-PLUNGER	22	V131-00-0220	GROMMET,NEEDLE	8
C334-00-0340	CONNECTOR, BRAKE	18	P003-00-5780	SPRING	22	V137-00-0140	GROMMET,FUEL	4
C345-00-0640	COVER,BRAKE	18	P003-00-5790	WASHER	22	V162-00-0760	PLUG	16
C400-00-1550	HANDLE, FRONT	16	P021-05-0120	PISTON KIT	2	V162-00-0770	PLUG	8
C418-00-0150	SHIELD, SNOW	26	P021-05-0130	CRANKCASE SET	2	V186-00-0020	JOINT,PIPE	4
C450-00-0950	CONTROL, THROTTLE	16	P021-05-0140	STRAINER, OIL ASY	2	V186-00-0510	JOINT,PIPE	4
C454-00-0540	ROD, THROTTLE	16	P021-05-0160	COIL, IGNITION	6	V186-00-0530	JOINT,PIPE	4
C460-00-0590	LOCKOUT, THROTTLE	16	P021-05-0171	HANDLE SET, REAR	16	V203-00-0041	BOLT,5	18
C646-00-0132	RING,HARNESS	16	P021-05-0190	CLUTCH SHOE SET	18	V203-00-2250	BOLT,5	6
C649-00-0420	HOOK	18	P021-05-0202	GUARD, SPROCKET ASY	18	V203-00-2260	BOLT,5	4
C649-00-0440	HOOK	4	P021-05-1910	ENGINE COVER ASY	4	V203-00-2270	BOLT,5	18
P003-00-0380	THROTTLE, LEVER	10	P021-05-1920	CYLINDER	2	V203-00-2280	BOLT,5	4
P003-00-0410	VALVE CHOKE	10	P022-03-6670	SPRING,DAMPER	14	V225-00-0262	BOLT,STUD 8	4

NUMERICAL PARTS INDEX

Part No	Part description	Page	Part No	Part description	Page	Part No	Part description	Page
V265-00-0140	NUT	6	V471-00-3820	PIPE	4	V805-00-0240	BOLT, TORX 5	26
V265-00-0550	NUT,8	18	V471-00-4870	PIPE	4	X100-00-0060	BAR,GUIDE 20	24
V308-00-0030	WASHER,CIRCULAR 11	2	V490-00-0500	CLIP	4	X101-00-0011	BAR,GUIDE 25	24
V341-00-0200	WASHER,SQUARE	4	V505-00-0070	OIL SEAL	2	X101-00-0200	BAR,GUIDE 25	24
V351-00-0030	COLLAR,3	8	V553-00-0020	BEARING,NEEDLE 8	2	X120-00-0021	BAR,GUIDE 20	24
V352-00-0300	COLLAR,4	6	V555-00-0190	BEARING,NEEDLE 10	18	X121-00-0003	BAR,GUIDE 25	20
V355-00-0840	COLLAR,8	18	V606-00-0020	PIN,ENG 8	2	X121-00-0003	BAR,GUIDE 25	24
V355-00-0860	COLLAR,8	18	V651-00-0011	GEAR,BEVEL	18	X122-00-0073	BAR,GUIDE 30	24
V356-00-0780	COLLAR,10	18	V651-00-1060	GEAR,BEVEL	18	X200-00-0000	CHAIN,SAW	24
V358-00-0220	COLLAR,14	8	V652-00-0230	GEAR,WORM	2	X220-00-0020	CHAIN,SAW	24
V376-00-0450	SPACER	18	V804-00-0000	BOLT, TORX 4	4	X221-00-0100	CHAIN,SAW	20
V450-00-2050	SPRING, COMPRESSION	4	V804-00-0000	BOLT, TORX 4	18	X221-00-0100	CHAIN,SAW	24
V450-00-2060	SPRING, COMPRESSION	4	V804-00-0010	BOLT, TORX 4	4	X222-00-0140	CHAIN,SAW	24
V450-00-2070	SPRING, COMPRESSION	4	V804-00-0010	BOLT, TORX 4	12	X490-00-0840	SCABBARD,CHAIN	20
V450-00-2080	SPRING, COMPRESSION	18	V804-00-0010	BOLT, TORX 4	16	X502-00-0340	LABEL,ECHO	18
V452-00-0030	SPRING,TORSION	6	V804-00-0040	BOLT, TORX 4	8	X502-00-1030	LABEL,ECHO	14
V452-00-1650	SPRING,TORSION	16	V804-00-0050	BOLT, TORX 4	2	X503-01-4140	LABEL,MODEL	8
V452-00-1660	SPRING,TORSION	18	V804-00-0060	BOLT, TORX 4	6	X505-00-7710	LABEL,CAUTION	12
V470-00-2171	PIPE	2	V804-00-0060	BOLT, TORX 4	14	X505-00-8600	LABEL,CAUTION	4
V470-00-2180	PIPE	4	V804-00-0100	BOLT, TORX 4	2	X602-00-0160	PLUG WRENCH	20
V470-00-2190	PIPE	4	V804-00-0100	BOLT, TORX 4	4	X605-00-0190	TOOL,L WRENCH	20
V470-00-2200	PIPE	2	V805-00-0000	BOLT, TORX 5	16			
V470-00-2210	PIPE	4	V805-00-0070	BOLT, TORX 5	8			
V471-00-3660	PIPE	4	V805-00-0150	BOLT, TORX 5	12			