

9 Explosionszeichnungen und Ersatzteillisten

WICHTIG

Die Spalte „Bemerkung“ hilft Ihnen, Teile zu identifizieren.

Verwenden Sie ausschließlich Originalersatzteile vom Hersteller. Dadurch wird die sichere Funktion des Gerätes gewährleistet.

Verschleißteile sind in Klammern.

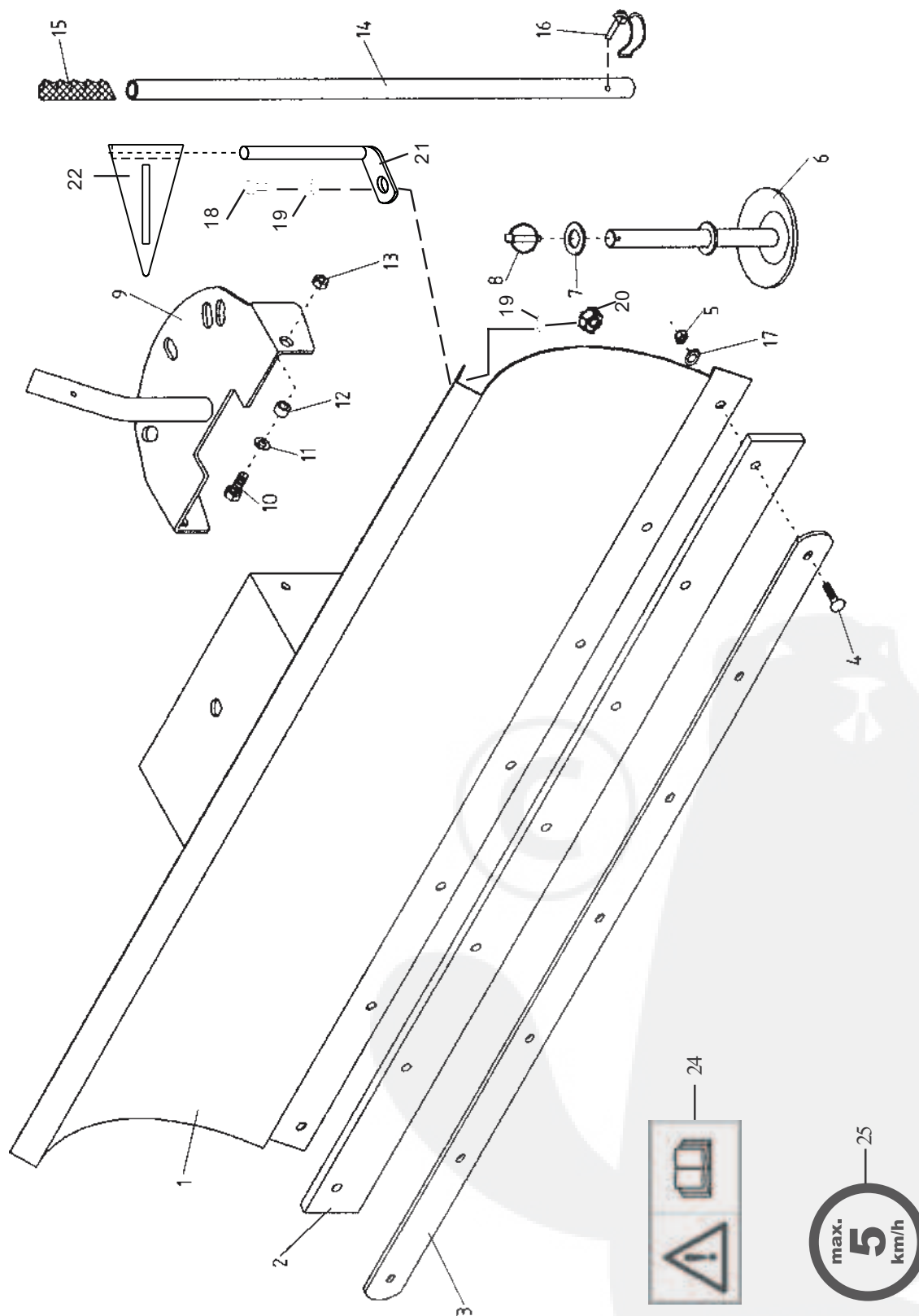

Pos.-Nr. Rep. Pos. Pos. Bilde-Nr.	Bestellnummer Référéce Article number Nr. codice Bestillings-Nr.	Anzahl Qté. Quant. Q.tà Antall	Désignation 	Description 	Description 	Descrizione 	Benevnelse 	Bemerkung
1	AE-015-140-9005	1	Schild	Lame	Shield	Lama	Brett	
(2)	HK-003-008	1	Gummileiste	Bande caoutchouc	Rubber bar	Lista gomma	Gummilist	
3	DB-250-029-9005	1	Schiene	Rail	Rail	Sbarra	Skinne	
4	HO-032-085z	7	Flachrundschrabe	Vis à tête bombée	Cut head bolt	Vite testa tonda	Flatrundskruue	
5	HR-030-005z	7	Sicherungsmutter	écrou de sûreté	Locknut	Dado autobloccante	Låsemutter	M 8,4
(6)	AE-015-146z	2	Kufe	Patin	Slide	Pattino/Slitta		
7	HW-010-017z	30	Scheibe	Rondelle	Washer	Rondella	Skive	B 10,5
8	AZ-008-005	2	Klappsplint	Goupille	Hinged pin	Spina sicurezza	Orepinne	
9	AE-015-147z	1	Rastplatte					
10	HO-020-115z	2	Sechskantschraube	Vis à six pans	Hexagon bolt	Vite esagonale	Sekskantskrue	M 10 x 25
11	HW-050-009z	2	Scheibe	Rondelle	Washer	Rondella	Skive	B 10,5
12	DN-060-006	2	Abstandshülse	Douille d'écartement	Spacer tub	Boccola distanziale	Avstandshylse	
13	HR-010-006z	2	Sechskantmutter	écrou à six pans	Hexagon nut	Dado esagonale	Sekskantmutter	
14	DN-090-017-9005	1	Rohr	Tuyau	Tube	Tube	Rør	
15	HJ-010-013	1	Griff	Poignée	Handle	Leva	Handtak	
16	AZ-008-008z	1	Rohr-Klappsplint	Tuyau-Goupille	Tube-Hinged pin	Tube-Spina sicurezza	Rør-Orepinne	
17	HW-050-007z	7	Scheibe	Rondelle	Washer	Rondella	Skive B 10,5	
18	HO-020-054z	2	Sechskantschraube	Vis à six pans	Hexagon bolt	Vite esagonale	Sekskantskrue	M 6 x 16
19	HW-010-004z	4	Scheibe	Rondelle	Washer	Rondella	Skive B 6,4	
20	HR-010-004z	2	Sechskantmutter	écrou à six pans	Hexagon nut	Dado esagonale	Sekskantmutter	
21	DC-040-042-9005	2	Fahnenstange					
22	HJ-010-163	2	Fahne orange					
23	AE-015-090	Pos. 18-22	Fahnenhalter kpl.					
24	KD-003-050	1	Aufklber	Autocollant	Lable	Autoadesivo Dekal		
25	KD-003-079	1	Aufklber	Autocollant	Lable	Autoadesivo Dekal		

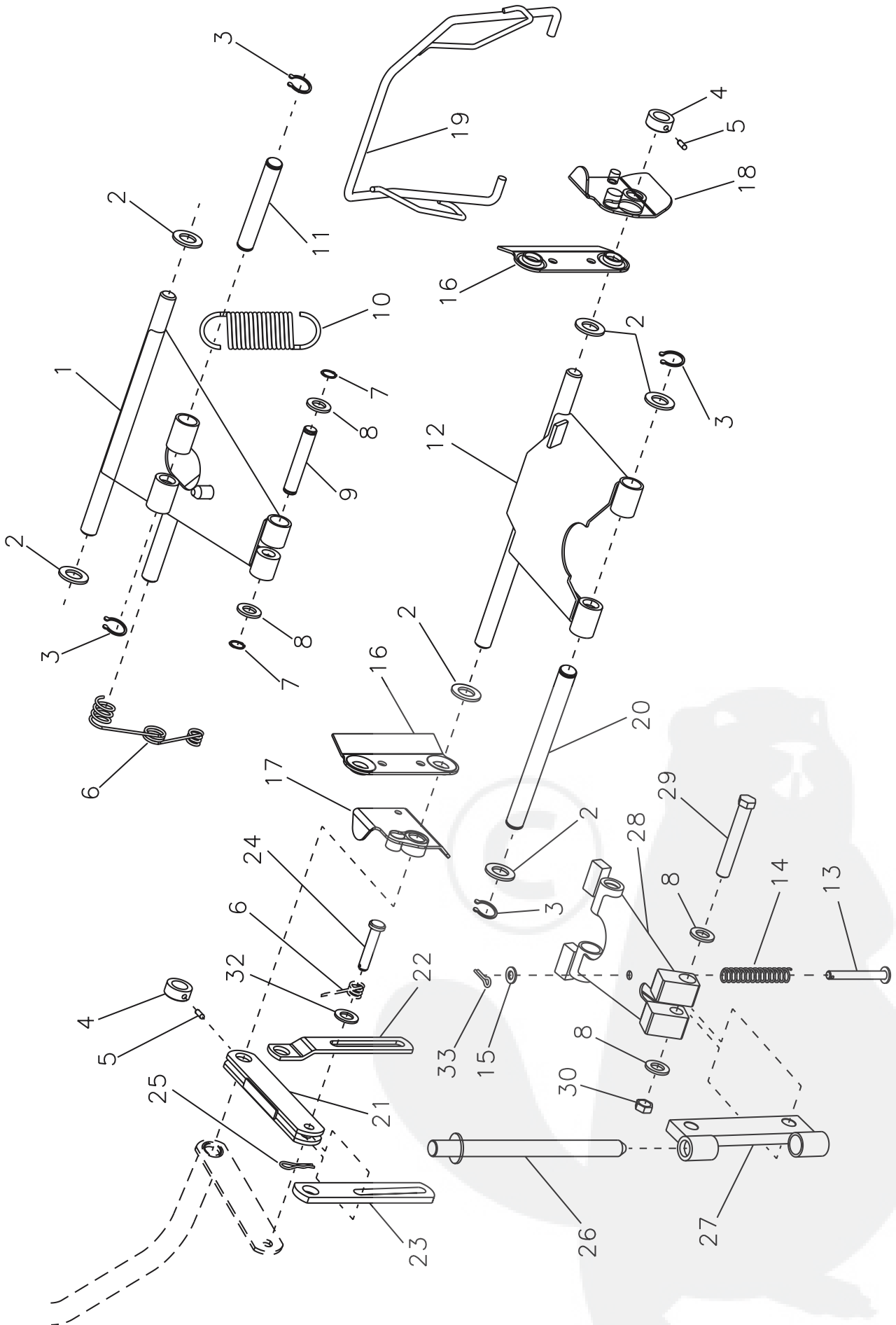



Pos.-Nr. Rep. Pos. Pos. Bilde-Nr.	Bestellnummer Référéce Article number Nr. codice Bestillings-Nr.	Anzahl Qté. Quant. Q.tà Antall	Désignation	Description	Descrizione	Benevnelse	Bemerkung
1	AE-015-141z	1	Oberlenker		Top carrier		
2	HW-010-017z	6	Scheibe	Rondelle	Washer	Rondella	Skive B 21
3	HU-010-020z	4	Sicherungsring	Anneau d'arrêt	Retaining ring	Seger	Semering
4	KC-001-005z	2	Stellring	Bague de reglage	Clampring	Collare	Ring A 20
5	HP-022-051z	2	Gewindestift	Cheville	Slotted set screw	Spina filettata	Gjengestift M 6 x 8
6	HI-040-024z	1	Drehfeder	Ressort	Spring	Molla	Fjær
7	HU-010-016z	2	Sicherungsring	Anneau d'arrêt	Retaining ring	Seger	Semering A 16
8	HW-010-014z	4	Scheibe	Rondelle	Washer	Rondella	Skive B 17
9	DC-141-052z	1	Bolzen	Boulon	Pin	Bullone	Bolt
10	HI-010-021-9005	1	Zugfeder	Ressort de traction	Extension spring	Molla di trazione	Fjær
11	DC-181-064z	1	Federbolzen	Ressort de Boulon	Springpin	Molla di bullone	Fjærbolt
12	AE-015-142z	1	Unterlenker, hinten		Lower carrier, rear		
16	DA-241-027z	2	Lagerlasche	Tirant de roulement	Bearing tongue	Staffa cuscinetto	Lagerfeste
17	AD-200-142z	1	Schloß, rechts	Cadenas, droite	Lock, right	Lucchetto, dx destro (a)	
18	AD-200-141z	1	Schloß, links	Cadenas, gauche	Lock, left	Lucchetto, sx sinistro (a)	venstre
19	AD-200-144z	1	Kupplungsbügel	Bride de connection	Clutch-handle	Staffa frizione	Clutchbøyle
20	DC-181-063z	1	Gelenkbolzen		Shaft		
21	AD-200-145z	1	Doppellasche	Tirant double	Double tongue	Staffa doppia	Feste dobbel
22	DB-210-078z	1	Lasche, gekröpft	Tirant	Tongue	Staffa	Feste
23	DB-590-011z	1	Lasche	Tirant	Tongue	Staffa	Feste
24	KC-001-033z	1	Splintbolzen	Boulon	Clevis pin	Bullone copiglia	Splintbolt
25	KG-011-001z	1	Federstecker	Support de fiche	Hairpin clip	Spina elastica	Låsesplint
26	AE-015-145z	1	Ansteckbolzen	Broche	Coupling pin	Perno di fissaggio	Bolt
27	AE-015-144z	1	Gelenkleiste		Hinge bar		
28	AE-015-143z	1	Unterlenker, vorn		Lower carrier, font		
29	HO-010-195z	1	Sechskantschraube	Vis à six pans	Hexagon bolt	Vite esagonale	Sekskantskrue M 16 x 100
30	HR-080-009z	1	Sicherungsmutter	écrou de sûreté	Locknut	Dado autobloccante	Låsemutter M 16
32	HW-010-011z	2	Scheibe	Rondelle	Washer	Rondella	Skive