

ISO 9001
CERTIFIED

shindaiwa

INSTRUCTION MANUAL

CUT-OFF MACHINE

EC7500

EC7600

CE

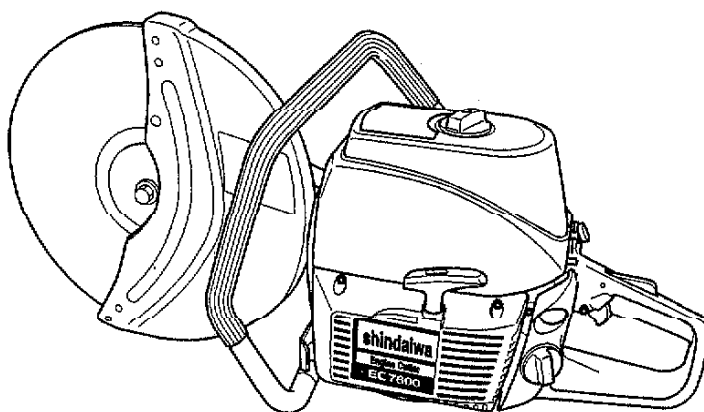

WARNING!

- ◆ Read this manual and familiarize yourself with its contents.
- ◆ This machine is designed for cutting mainly building construction materials and cutting metal according to the specific type of cutting-off wheel selected.
- ◆ Minimize the risk of injury to yourself and others.
- ◆ Always wear an ear muffler, a dustproof mask, goggles and a helmet when operating this machine.
- ◆ Do not operate or service this machine unless you clearly understand this manual.
- ◆ Keep this manual at a particular place so that you can reread it whenever you have a question about its use.

CONTENTS

	PAGE
1 ATTENTION STATEMENT	2
2 LABELS AND SYMBOLS.....	2
3 SAFETY PRECAUTIONS	3
4 PRODUCT DESCRIPTION	10
5 TECHNICAL SPECIFICATIONS.....	12
6 ASSEMBLY PROCEDURE	13
7 STARTING/STOPPING THE ENGINE	14
8 OPERATION.....	18
9 UNIT CONDITION CHECK & MAINTENANCE	20
10 LONG TERM STORAGE.....	27
11 TROUBLE SHOOTING	28
12 EUROPEAN DISTRIBUTORS LIST.....	29
13 DECLARATION OF CONFORMITY.....	30

1 ATTENTION STATEMENT

Through out this manual are special “attention statements” surrounded by boxes and preceded by the triangular Attention Symbol.



WARNING!

A statement preceded by the word “WARNING” contains information that should be acted upon to prevent serious injury.



CAUTION!

A statement preceded by the word “CAUTION” contains information that should be acted upon to prevent machine damage.

Additional attention statements that are not preceded by the Attention Symbol are;

IMPORTANT!: A statement preceded by the word “IMPORTANT” is one that possesses special significance.

NOTE: A statement preceded by the word “NOTE” contains information that is handy to know and may make your job easier.

2 LABELS AND SYMBOLS

The labels and symbols indicated on the machine mean as follows.



Read and follow the operator's manual. Failure to do so could result in serious injury.



Always wear an ear muffler, a dustproof mask, goggles and a helmet when operating this machine.



BE AWARE OF KICKBACK!

Kickback may force the the cutting-off wheel up and back toward the operator with a lightning-fast reaction. Kickback can occur whenever the upper-half of the cutting-off wheel touches an object while operating the machine.



BE AWARE OF THROWN OBJECTS!

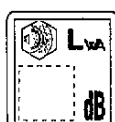

SOUND POWER LEVEL

(measured in accordance with 2000/14/EC)

Fuel Filling Opening



Ratio of Fuel/Oil Mixture

25:1

No Fire Allowed



On-off Switch

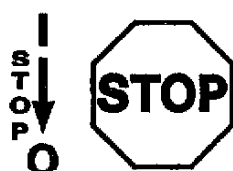

Choke



Wheel Rotating
Direction

Max Spindle
Speed/Rated Spindle
Speed

Rated spindle speed



3 SAFETY PRECAUTIONS

WARNING!



1) Before Operation

- (1) Young children and persons who have not understood this manual should not use this machine.
- (2) Never allow any other persons or animals to be near the machine when starting or operating the machine.
- (3) Never touch a rotating cutting-off wheel.
- (4) Operate the machine only in a well-ventilated area. Never operate it in a closed area such as a room, warehouse or tunnel. Running the machine in a closed area may cause you serious illness or even death due to exhaust gas and dust.
- (5) Never allow any other persons or animals in a direction of exhaust gas.
- (6) Never inhale exhaust gas.
- (7) Never make any unauthorized modifications or alternations to any of the components and never operate the machine without the wheel guard or muffler.
- (8) This machine is designed for oneman operation. It must be operated by one person.
- (9) Never operate the machine when you are tired or under influence of any substance, e.g. drugs or alcohol, which can impair vision, dexterity or judgement.



WARNING! (continued)

- (10) When operating, always wear snug-fitting clothing, safety gloves, safety non-skid footwear, an ear muffler, a dust-proof mask, a helmet and goggles. Never wear floppy clothing, a necktie, accessories, shorts and sandals.
- (11) Never operate the machine in rain because the ground may be slippery.
- (12) Never use any cutting-off wheel which is not recommended in this manual.
- (13) Do not start or operate the machine unless you have a clear work area and secure footing.
- (14) Do not operate the machine for no more than two hours a day in total. Do not operate it for no more than ten minutes continuously.
Due to vibration, excessive operation may cause you white finger disease.
- (15) Never smoke or use fires near the machine or fuel.
- (16) The muffler and exhaust gas become very hot. Make sure there are no flammable substances and gases near the machine.
- (17) Check if there is any fuel leak. Never run the machine if fuel leak is found.
- (18) A first-time operator should obtain practical instruction from a dealer or an experienced user before using the machine.
- (19) Make sure all the components are in place and the bolts are securely fastened.
- (20) Make sure the cutting-off wheel is securely fastened and is not damaged. Never use a cutting-off wheel which has cracks, distortion of shape or is unbalanced.
- (21) Make sure the belt tension is properly adjusted and the wheel guard, transmission guard and clutch cover are securely assembled.



WARNING! (continued)

The Properly Equipped Operator



2) Kickback

Kickback may force the the cutting-off wheel up and back toward the operator with a lightning-fast reaction.

Kickback can occur whenever the upper-half of the cutting-off wheel touches an object. Never cut an object using the upper-half of the cutting-off wheel.

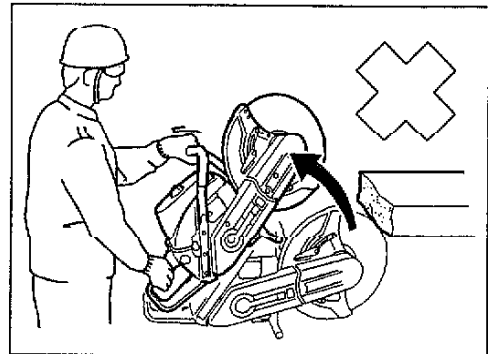

3) Filling Fuel

(1) Mixing fuel and 2-cycle engine oil and fueling must be done outside where there is nothing to start a fire around.

(2) Open the fuel cap slowly to release any possible build-up of pressure.

Never refuel when the machine is hot. Allow to cool before refueling.

Never fuel when the engine is running



WARNING! (continued)

- (3) After fueling, wipe all spilled fuel. Cutting metal may cause sparks from the cutting-off wheel and may ignite spilled fuel which may result in serious injury.
- (4) Fuel must be handled with a lot of care. Fuel must be stored in a safe place where there is nothing to start a fire.

4) Starting The Engine

- (1) When starting the engine, make sure the cutting-off wheel does not touch any object or ground. As soon as the engine starts, the cutting-off wheel starts rotating.

- (2) Start the engine following the instruction indicated in this manual. Start the engine at a stable place and make sure there is nobody around. Starting the engine must be done by only one person without any assistance.

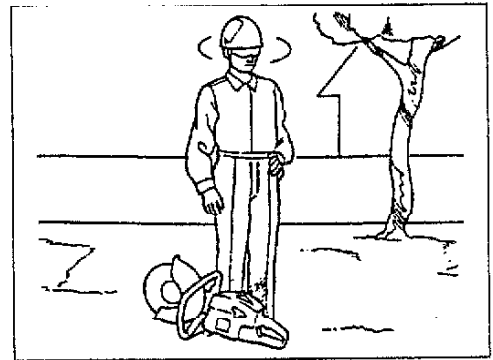

- (3) The cutting-off wheel should not rotate at engine idle. If it rotates at engine idle, adjust the idle speed lower.

- (4) Starting the engine must be done at least 3m away from the fueling point.

- (5) Never leave the machine running unattended.

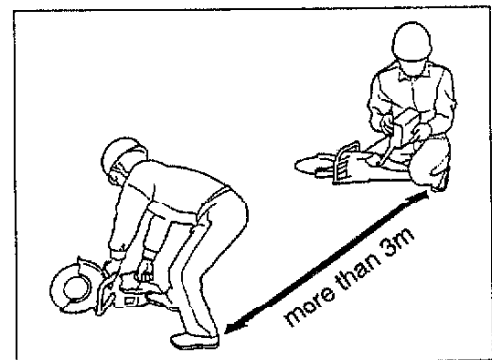



WARNING! (continued)

5) Operation

- (1) This machine must be operated below your chest. Operating it above the chest is very dangerous and may result in serious injury.
- (2) The machine must be held firmly with both hands, the one is on the rear handle and the other on the front handle. Never hold any other parts of the machine.
- (3) When cutting vertically, the machine should be positioned horizontally or with the wheel side slightly tilted down. When cutting horizontally, the recoil stater side should face upward.
- (4) Winding cutting, prying cutting or using sides of the cutting-off wheel must not be done.
- (5) Keep proper footing and stable position. Do not overreach.
- (6) When working in a group, make sure each operator must be at least 10m away from the other operators.
- (7) If you drop the machine or bang it into something, immediately stop the engine and check if there is any damage. If any damage is found, have it repaired before you restart operating it.
- (8) Check regularly if the fuel cap is securely tightend. Retighten it regularly to prevent fuel from leaking.
- (9) When fuel leak is found, immediately stop the engine.
- (10) Cutting may cause sparks from the cutting-off wheel. Make sure there is no flammable substances around.
- (11) Never cut live wires. You may get an electric shock.

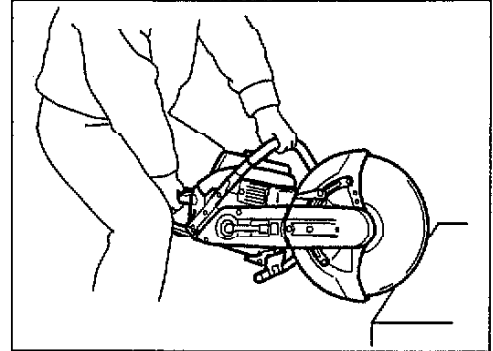



WARNING! (continued)

- (12) Do not touch hot parts such as the muffler, cylinder and so forth. You may burn yourself.
- (13) The cutting-off wheel gets hot while cutting. Never touch the wheel immediate after cutting. You may burn yourself.
- (14) While the engine is running, never touch high voltage parts such as the spark plug cap, plug cord and so forth.
- (15) The machine must not be used where flammable substances and gases are present.

6) Stopping The Engine

- (1) The cutting-off wheel coasts for a while even after the engine is stopped. Keep holding the machine firmly until the wheel stops completely and then place it on the ground.

7) Unit Condition Check & Maintenance

- (1) Before performing any condition check, maintenance, repair or cleaning work on the machine, make sure the engine and the cutting-off wheel are completely stopped and cooled down.
- (2) Unit condition check and maintenance should be done in a well ventulated place where there is nothing to start a fire.
- (3) When replacing parts, always use Shindaiwa genuine parts. Using non-Shindaiwa genuine parts may result in serious injury.
- (4) Unit condition check and maintenance not mentioned in this manual should be performed by a Shindaiwa dealer.

8) Transport & Storage

- (1) When carrying the machine, make sure the engine and the cutting-off wheel are completely stopped.



WARNING! (continued)

- (2) Carry the machine holding the front handle with the cutting-off wheel facing backward.
- (3) When storing the machine, make sure the cutting-off wheel is removed and the machine is placed on a stable and dry place.
- (4) Keep it away from young children.
- (5) When storing the machine for more than a couple of days, empty the fuel tank.
- (6) Store gasoline in a closed dry place where there is nothing to start a fire.

4 PRODUCT DESCRIPTION

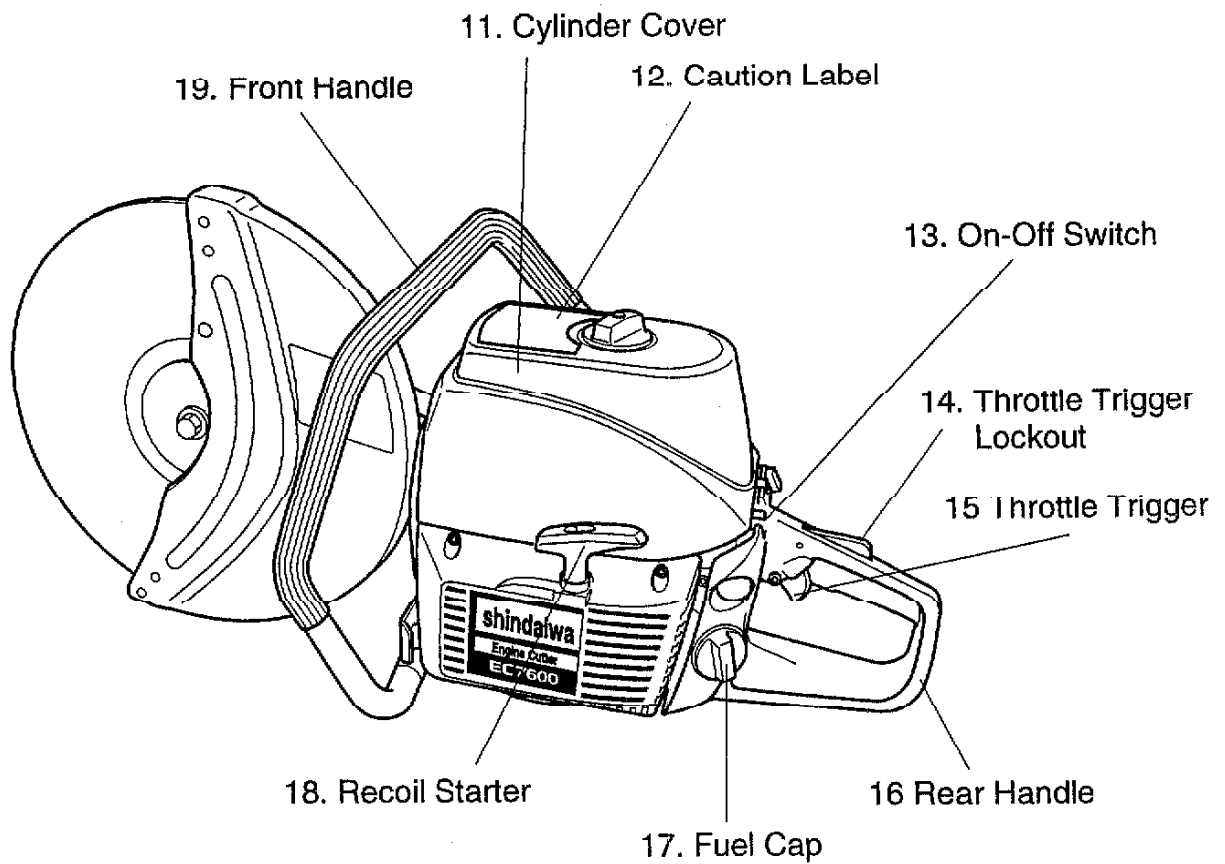
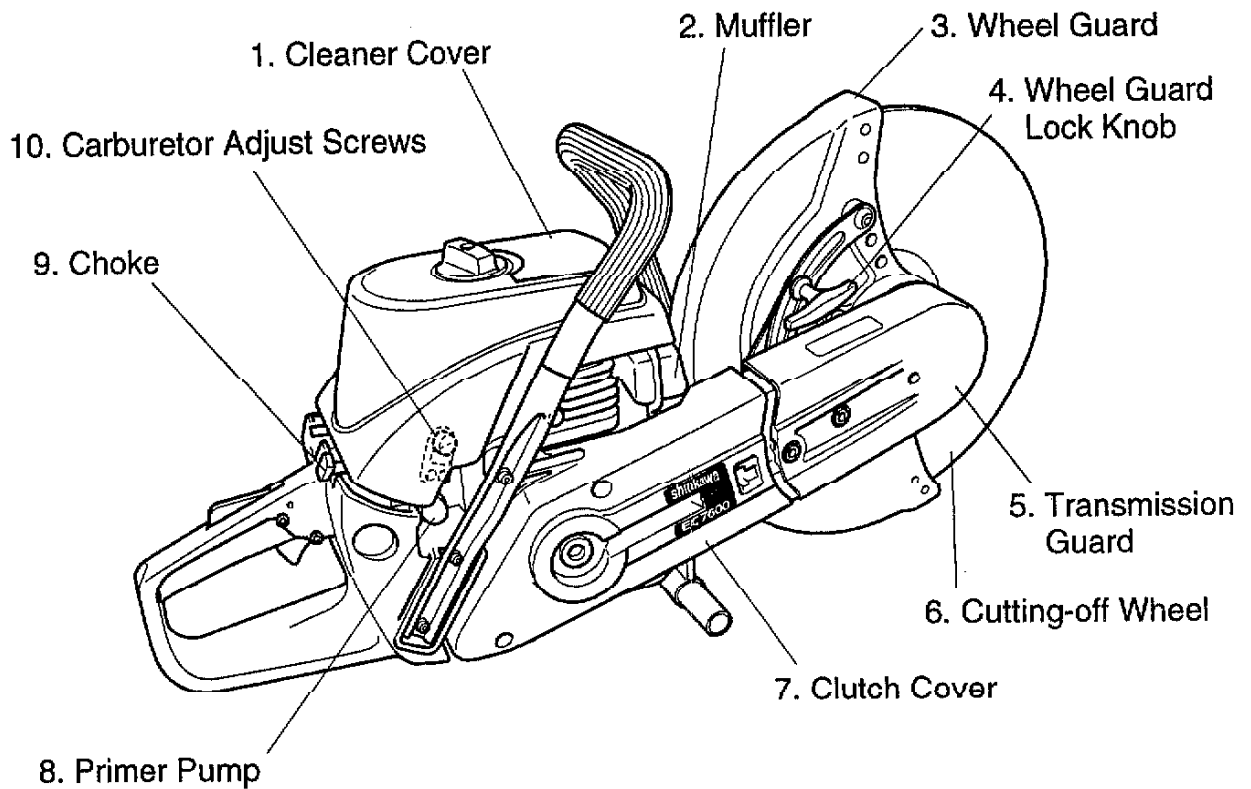

Description of Each Function

	Items	Function
1	Cleaner Cover	A lid which covers the air cleaner.
2	Muffler	Device for reducing engine exhaust noise and directing the exhaust gases.
3	Wheel Guard	A wheel guard is an enclosure for the cutting-off wheel.
4	Wheel Guard Lock Knob	To lock the position of the wheel guard.
5	Transmission Guard	To cover the pulley and V-belt.
6	Cutting-off Wheel	This rotates at high speed to cut an object.
7	Clutch Cover	To cover the clutch and V-belt.
8	Primer Pump	A device for supplying extra fuel to aid starting.
9	Choke	A device for enriching the fuel air mixture in the carburetor, to aid starting.
10	Carburetor Adjust Screws	To adjust idle speed and low speed.
11	Cylinder Cover	A lid to cover the cylinder, muffler and carburetor.
12	Caution Label	To show major cautions.
13	On-Off Switch	A switch to start and stop the engine.
14	Throttle Trigger Lockout	A safety lever. The throttle trigger can not be pulled unless this is depressed.
15	Throttle Trigger	To control engine speed.
16	Rear Handle	A rear-side handle to be held by the right hand.
17	Fuel Cap	A cap to seal the fuel tank.
18	Recoil Starter	To start the engine by pulling the grip.
19	Front Handle	A front-side handle to be held by the left hand.

5 TECHNICAL SPECIFICATIONS

Model Name		EC7500	EC7600	
Engine Type		2-Cycle, Vertical-Cylinder, Air-Cooled		
Displacement		73.5cm ³		
Bore x Stroke		51 x 36mm		
Maximum Power Output (*1)		3.3kW		
Recommended Engine Speed at Idling		2,500min ⁻¹		
Recommended Maximum Engine Speed		10,450min ⁻¹		
Max. Cutting Depth	Abrasive Wheel	102mm (305mm wheel)	127mm (355mm wheel)	
	Diamond Wheel	109mm (320mm wheel)	129mm (360mm wheel)	
Rated Spindle Speed (*2)		3,800min ⁻¹	3,320min ⁻¹	
Max. Spindle Speed (*2)		4,180min ⁻¹	3,650min ⁻¹	
Max. Peripheral Wheel Speed (*2)		67m/s	68m/s	
Speed Reduction Ratio		2.50	2.87	
Type of Fuel		Unleaded Gasoline + 2-cycle engine oil (25:1)		
Fuel Tank Capacity		800 cm ³		
Type of Carburetor		Diaphragm		
Ignition		Electronic Ignition System		
Spark Plug		NGK, BPMR7A		
Starting		Toggle Switch + Recoil Starter		
Stopping		Toggle Switch		
Power Transmission		Automatic Centrifugal Clutch, V-Ribbed Belt		
Anti-Vibration Structure		Unified Handles With 7-Point Support		
Safety Devices		Throttle Lock-out, Wheel Guard		
Dry Weight (without wheel)		10.0kg	10.5kg	
Dimensions (L x W x H)		740 x 220 x 375mm	765 x 220 x 390mm	
Sound Pressure Level (*3)		101 dB (A)	101 dB (A)	
Sound Power Level (*4)		108 dB (A)	111 dB (A)	
Vibration Level (*5)	Front Handle (Idle/Rated Spindle)	6.96/5.48m/s ²	10.09/10.49m/s ²	
	Rear Handle (Idle/Rated Spindle)	8.61/14.60m/s ²	8.93/13.70m/s ²	
Recommended Cutting-off Wheels	Abrasive Wheel	Diameter	305mm	355mm
		Inner Bore Diameter	20mm	
		Max Permitted Speed	100m/s or more	
	Diamond Wheel	Diameter	320mm	360mm
		Inner Bore Diameter	20mm	
		Max Permitted Speed	100m/s or more	

*1: Measured in accordance with ISO 7293: 1983.

*2: Measured with 305mm wheel (EC7500) and 355mm wheel (EC7600).

*3: Measured in accordance with EN ISO 11201: 1995.

*4: Measured in accordance with EN ISO 3744: 1995.

*5: Measured in accordance with EN 28662-1: 1992.

6 ASSEMBLY PROCEDURE

1) Prior to Assembly

Before assembling, make sure you have all the components required for a complete unit. This machine consists of the items illustrated here.

Carefully inspect the engine unit for damage or loosen bolts. If you find any damage or missing items, ask your dealer for consultation.

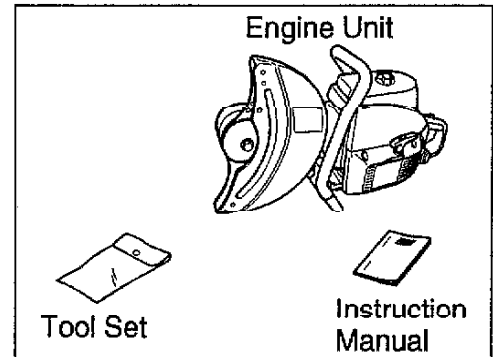

2) Mounting Cutting-off Wheel

- (1) Select an appropriate cutting-off wheel for your work. Appropriate cutting objects are shown on the wheel or in its instruction manual.

Appropriate Cutting-off Wheels

Model	Type of Wheel	Inner Bore	Outer Diameter	Max. Permitted Speed
EC7500	Abrasive	20mm	305mm	100m/s or more
	Diamond		320mm	
EC7600	Abrasive		355mm	
	Diamond		360mm	



WARNING!
Using an inappropriate cutting-off wheel may cause wheel breakage and may result in serious injury.

- (2) Make sure the switch is off and the engine is stopped.
- (3) Insert the hex wrench into the hole in the transmission guard to prevent the drive-shaft from turning.
- (4) Loosen the bolt with the wrench and remove the bolt and outer flange.
- (5) Place the cutting-off wheel so that the inner bore is properly set onto the collar.

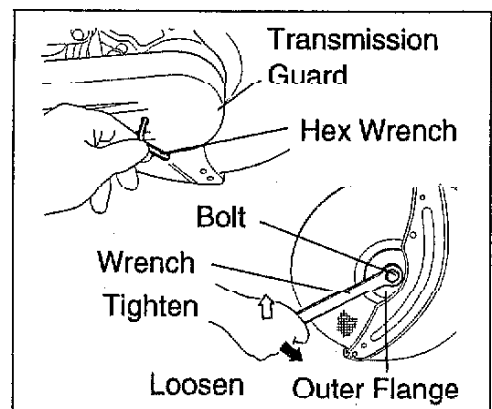

- (6) Replace the outer flange and bolt, and then holding the hex wrench in the hole of the transmission guard, tighten the bolt with the wrench.
- (7) Make sure the cutting-off wheel is securely fastened and does not wobble.

7 STARTING/STOPPING THE ENGINE

1) Fuel Filling



WARNING!

When filling fuel, make sure the engine is stopped and is cooled down.

Filling fuel or mixing fuel and oil must be done in a place where there is no fire around.



CAUTION!

Use mixed fuel, unleaded gasoline and 2-cycle engine oil. For the first 20 hours, the mixing ratio should be 20:1.

Always use fresh and clean gasoline and oil. Using 2 months or more old gasoline and oil may harm the engine.

Before fueling, clean the fuel cap and filler opening. Make sure no dust goes into the fuel tank while fueling.

Pour fuel very carefully and slowly so that no fuel is spilt.

- (1) Use a container to premix gasoline and oil. Pour oil first and then add gasoline. After using the machine for the first 20 hours, the mixing ratio of gasoline and oil should be 25:1.
- (2) Turn the fuel cap counterclockwise and take it off.
- (3) With the fuel cap hanging down from the filler opening, fill the fuel tank with the mixed fuel, and tighten the fuel cap securely.

- (4) If there is any fuel spilt on the machine, wipe it off completely, and then make sure there is no fuel leak.

2) Starting the Engine



WARNING!

Before starting the engine, place the machine on a clean, level surface. Make sure you have good secure footing and always keep a firm grip on the machine.

Move at least 3m away from the fueling site before starting the engine.

Make sure the cutting-off wheel is well clear of any interference. The cutting-off wheel may rotate when the engine starts.

Make sure nobody stands by.

Never start the engine without a cutting-off wheel.

a) When the engine is cold:

- (1) Turn the on-off switch on ("I" position).
- (2) Depress the primer pump a few times repeatedly until the primer pump is almost filled with fuel.
- (3) Pull the choke all the way out (choke closed). The throttle is automatically set at a fast idle position.
- (4) Place the machine on the ground.
- (5) Secure the machine by placing your right foot inside the rear handle and your left hand on the front handle as shown.

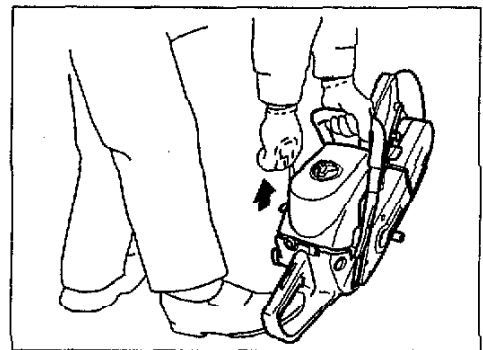
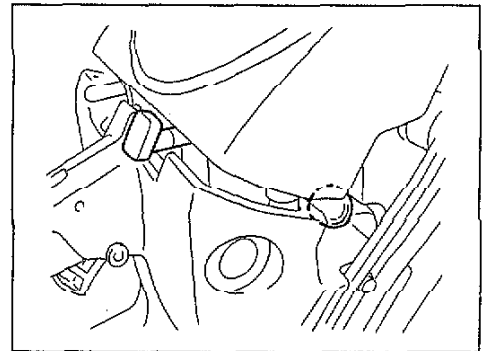

(6) Grip the starter handle with your right hand, pull the stater cord slowly until you feel the starter engages, then...

(7) ...start the engine by pulling the the stater cord upward rapidly.



CAUTION!

The recoil starter can be easily damaged from abuse.

Never pull the starter cord to its full length.

Always engage the starter before cranking the engine.

Always rewind the starter cord slowly.

(8) When the engine fires, push the choke in to its original position (choke open) if you have not done so.

(9) If the engine does not continue to run, pull the recoil again.

(10) As the engine starts, clear excess fuel from the combustion area by revving the engine several time.

IMPORTANT!

- The throttle trigger can not be moved without first depressing the lockout lever.
- Operating the throttle will automatically disengage the fast idle setting.

(11) Let the engine run at idle speed for a couple of minutes.



WARNING!

The cutting-off wheel must not rotate at idle speed. If it rotates, lower idle speed by adjusting the idle adjust screw.

b) When the engine is warm:

(1) Turn the on-off switch on ("I" position).

(2) Pull the choke all the way out and push it back to the original position (choke open). The throttle is automatically set at a fast idle position.

(3) Follow the procedure a)-(4) ~ (11) mentioned above.

c) If the engine does not start:

Repeat the appropriate starting procedure for a cold or warm engine. If the engine still does not start,

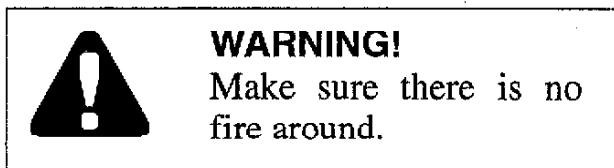

(1) Pull the choke all way out.

(2) Unscrew the knob on the cleaner cover and remove the cleaner cover. Unscrew the 2 bolts on the filter and remove the filter.

(3) Remove the plug cap and disconnect the spark plug by using the plug wrench, and check if the electrode is soaked with fuel.

(4) If the spark plug is soaked, dry it. Clear excess fuel from the combustion chamber by cranking the engine several times while the spark plug is removed.

(5) Reassemble the spark plug, plug cap, filter and cleaner cover securely.

(6) Follow the stating procedure a)-(1) ~ (11) mentioned above.

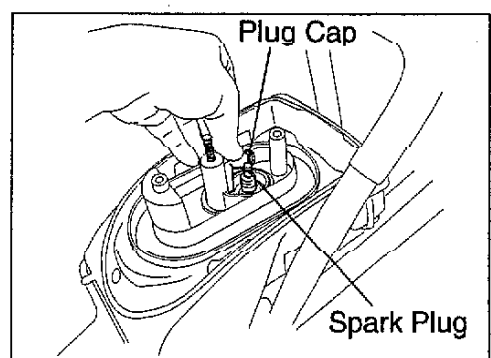
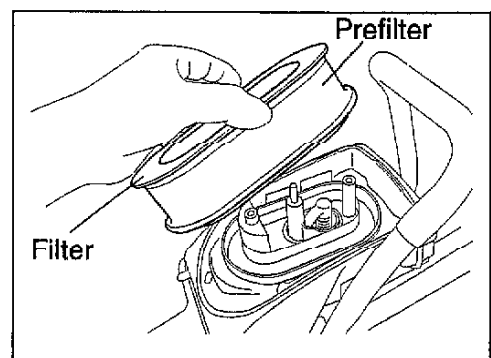
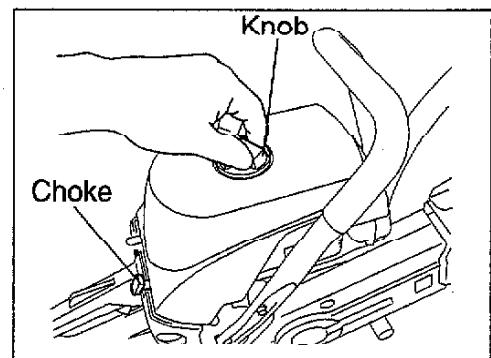

- (7) If the spark plug is dry, fuel is not supplied properly. Check the fuel filter and carburetor referring to 9. Unit Condition Check & Maintenance and 11. Troubleshooting in this manual. If the engine still does not start, have it repaired by your dealer.

3) Stopping the Engine

Turn the on-off switch off ("O" position) after letting the engine run at idle speed for a couple of minutes.

8 OPERATION



WARNING!

Never allow any other persons or animals to be near the machine when starting or operating the machine.

Kickback may force the the cutting-off wheel up and back toward the operator with a lightning-fast reaction. Kickback can occur whenever the upper-half of the cutting-off wheel touches an object. Never cut an object using the upper-half of the cutting-off wheel.

When operating, always wear snug-fitting clothing, safety gloves, safety non-skid footwear, an ear muffler, a dust-proof mask, a helmet and goggles.

1) Adjusting Wheel Guard Angle



WARNING!

When an abrasive cutting-off wheel is used, the wheel guard position must be fixed. If the wheel is broken by any chance, fragments may hit you and may result in serious injury unless the wheel guard position is securely fixed.

(1) When using an abrasive wheel:

Adjust the position of the wheel guard so that fragments will not fly toward you in case the wheel gets broken by any chance. Fix the position of the wheel guard by turning the lock knob clockwise.

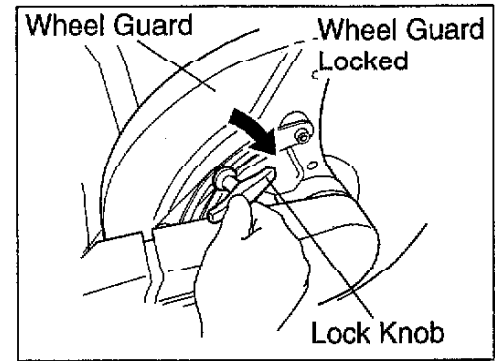

(2) When using a diamond blade:

The wheel guard position should normally be fixed like using an abrasive wheel, but it can also be used without fixing the position of the wheel guard.

In this case, turn the lock knob fully counterclockwise. The wheel guard moves freely and automatically comes back to the original position.

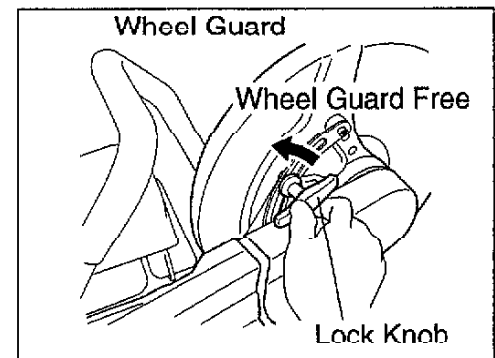

2) Cutting Operation

- (1) Make sure you have a clear work area and secure footing.
- (2) Position the cutting-wheel vertically to an object. Start cutting at a low speed and then accelerate the speed.

3) Efficient Cutting Operation

This machine performs most efficiently when cutting at 8,500 ~ 9,500min⁻¹ (rpm).

While running the engine at full throttle, give some pressure to the cutting-off wheel against an object so that the engine speed stays at 8,500 ~ 9,500min⁻¹.

Giving too much pressure to the wheel will lower the speed and this will considerably lower cutting efficiency.

9 UNIT CONDITION CHECK & MAINTENANCE



WARNING!

Unit condition check and maintenance should be done in a well ventilated place where there is nothing to start a fire.

LIST OF UNIT CONDITION CHECK & MAINTENANCE

No.	Item	What to do	Daily	Weekly	Monthly	If Necessary
1	Air Cleaner	Clean	○			
2	Carburetor	Adjust				○
3	Clutch Bearing	Grease		○		
4	Spark Plug	Check & Clean			○	
5	Cylinder Fin	Clean			○	
6	Fuel Filter	Clean			○	
7	Cutting-off Wheel	Check & Sharpen	○			
8	Belt	Check & Adjust		○		
9	Bolts/Screws	Check & Retighten	○			
10	Fuel Cap	Check Leakage	○			
11	Fuel Tank	Check Leakage	○			
12	Wheel Guard	Check Function	○			

1) Cleaning Air Cleaner

Dust in the air cleaner will affect the life of this machine. The air filter must be cleaned every time you start operating.

Cleaning: once a day

Replacing: every 20 hours

(1) Pull the choke lever so that dust will not go into the carburetor.

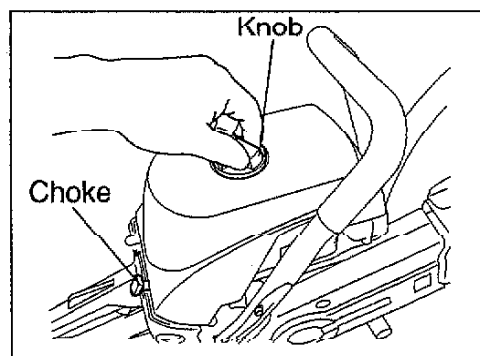

(2) Unscrew the knob on the cleaner cover and remove the cleaner cover and filter.

(3) Remove the prefilter from the filter.

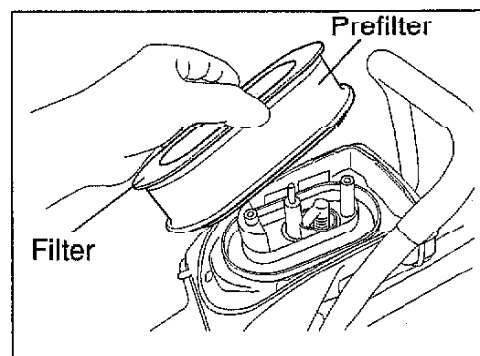

(4) If an air gun is available, blow air from inside the filter and prefilter respectively to remove dust. Otherwise, gently tap them to remove dust.

- (5) Replace the prefilter to the filter and reassemble them. Make sure the 2 bolts are securely tightened.
- (6) Replace the cleaner cover and make sure the knob is securely tightened.

When cleaning the Filter, the inner surface should also be cleaned. Before reassembling Filter, make sure the surface of Cylinder Cover where Filter is mounted is thoroughly cleaned.

2) Carburetor Adjustment

When the machine is brand new, it is not necessary to adjust the carburetor. Adjust the carburetor only when you are sure it is necessary due to differences in working conditions such as atmospheric pressure or temperature, or change in machine conditions after using for more than 10 hours. If you are not familiar with carburetor adjustment, ask your dealer for advice. Adjust the carburetor in accordance with the following procedure. Before adjusting, make sure to run the engine for a couple of minutes at idle speed and to clean the air cleaner.



WARNING!

When adjusting the carburetor, make sure nobody stands by and the cutting-off wheel is well clear of any interference. The wheel may rotate when adjusting the carburetor.

(1) Adjusting Idle Speed

Adjust idle speed so that the cutting-off wheel does not rotate at idle speed.

Recommended idle speed is 2,200 ~ 2,600min⁻¹ (rpm). Turning the idle adjust screw clockwise increases the speed.

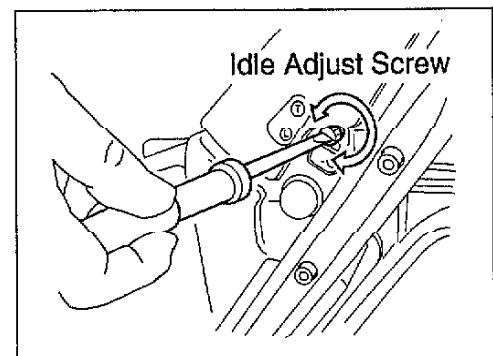

(2) Adjusting Low Speed Needle (L)



CAUTION!

Never run the engine at full throttle with no-load. This may cause seizure.
Never force to turn the needle. This may damage the carburetor.

a) It is normally unnecessary to adjust the low speed needle. Adjust it only when you feel acceleration is not good enough.

b) Standard setting of low speed needle is $1\text{-}1/2 \pm 1/4$ turns from the fully closed position.

c) Using a small screwdriver, adjust the low speed needle within the above mentioned range and set it where you feel the best acceleration.

d) After adjusting idle speed properly, turn the low speed needle gradually clockwise or counterclockwise whichever the engine speed increases, and continue turning it until the engine speed starts decreasing.

e) Turn the needle $1/2$ turns counterclockwise from the very point where the engine speed starts decreasing.

f) Depress the throttle trigger rapidly and see if acceleration is good.

g) If acceleration is not good, turn the low speed needle counterclockwise little by little while adjusting Idle speed to stay at $2,200\text{-}2,600\text{min}^{-1}$ (rpm) until you find good acceleration.

(3) High Speed Needle

The high speed needle is a fixed type. It is not possible to adjust it.

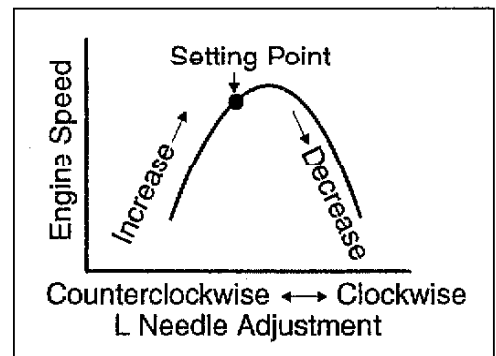
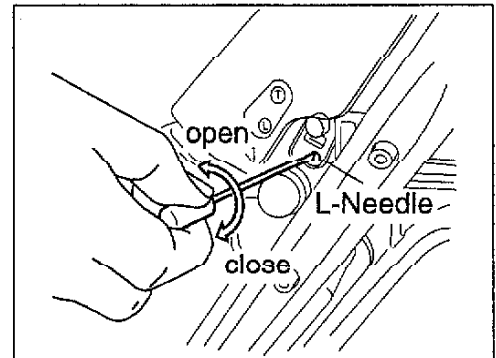

3) Spark Plug Maintenance

Inspect the spark plug when you find it hard to start the engine or idle speed becomes unstable.

(1) Remove the spark plug.
[See 7-2)-c).]

(2) Clean the electrode with a wire brush. If necessary, adjust the electrode gap. The gap should be 0.6mm.

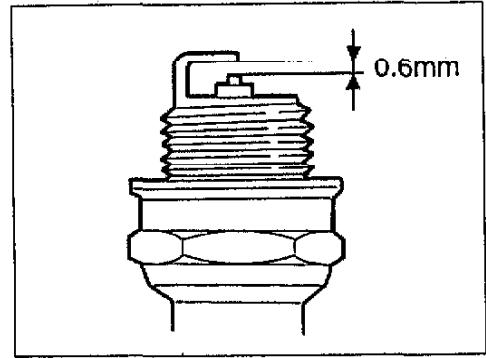

4) Cleaning Cylinder Fin

Dust may accumulate between the cylinder fins and this may cause overheating.

Make sure the engine is cold and clean the cylinder fins regularly.

5) Checking Belt

The belt tends to get loose and worn after some operation. Check the belt conditions regularly and adjust the belt tension if necessary. When the belt is worn out (e.g. wear, tear, scratches, cracks), immediately replace it with a new one.

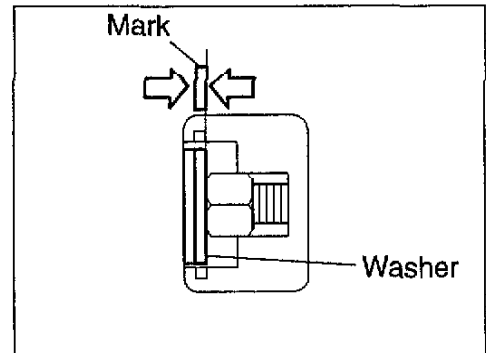

6) Adjusting Belt Tension

(1) Loosen the two bolts in the transmission guard by one turn.

(2) Turn the tension screw so that the washer aligns with the mark on the clutch cover.

(3) Tighten the two bolts in the transmission guard.

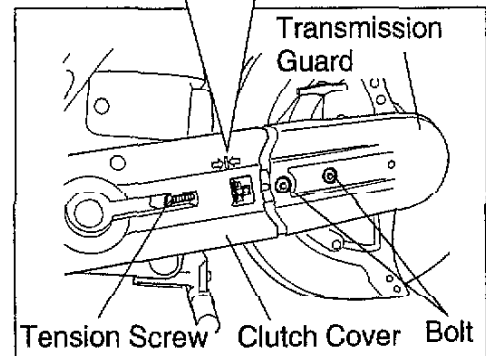

7) Replacing Belt

- (1) Loosen the tension screw. Loosen the two bolts in the transmission guard and remove the transmission guard by sliding it to the right.
- (2) Loosen the two bolts in the clutch cover and remove the clutch cover.
- (3) Replace the old belt with a new one.
- (4) Reassemble the clutch cover and the transmission guard and adjust the belt tension.

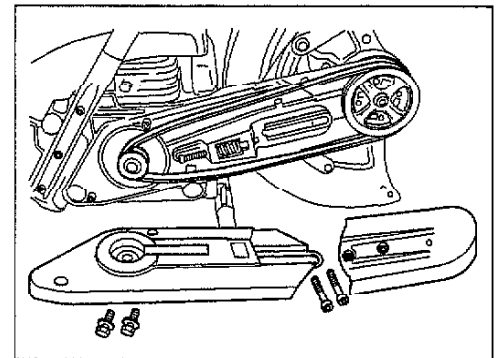
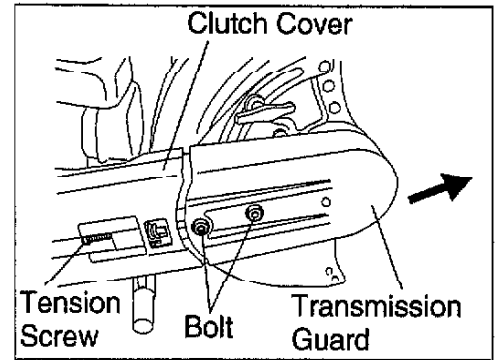

8) Checking Abrasive Cutting-off Wheel

Always check the condition of the wheel before starting the engine. Make sure there are no breakage, cracks or distortion. If there is any, immediately replace it with a new one.



WARNING!

Never use a wheel which has breakage, cracks or distortion. The wheel may get broken while operating and may result in serious injury.

9) Checking Diamond Cutting-off Wheel

Always check the condition of the wheel before starting the engine. Make sure there are no breakage, cracks or warp. If there is any, immediately replace it with a new one. Sharpen tips of the wheel regularly to maintain good cutting efficiency.



WARNING!

Never use a wheel which has breakage, cracks or distortion. The wheel may get broken while operating and may result in serious injury.

Bad Examples:

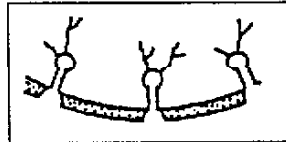

(cracks)

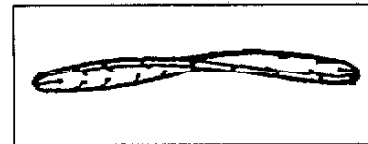

(distortion)

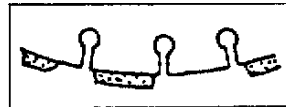

(missing tips)

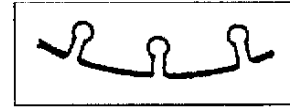

(worn tips)

10) Replacing Cutting-off Wheel

- (1) Make sure the switch is off and the engine is stopped.
- (2) Insert the hex wrench into the hole in the transmission guard to prevent the drive-shaft from turning.
- (3) Loosen the bolt with the wrench and remove the bolt and outer flange.
- (4) Remove the old wheel and place a new one. Make sure the inner bore is properly set onto the collar.
- (5) Replace the outer flange and bolt, and then holding the hex wrench in the hole of the transmission guard, tighten the bolt with the wrench.
- (6) Make sure the cutting-off wheel is securely fastened and does not wobble.

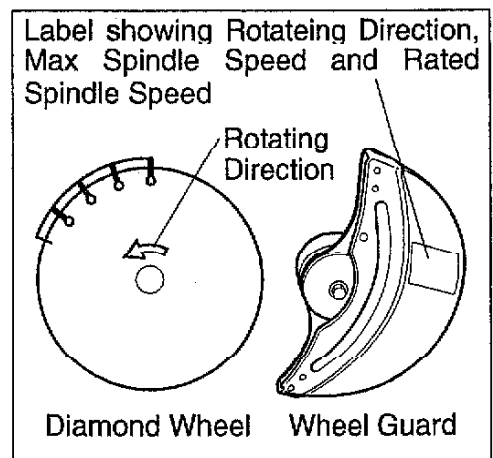
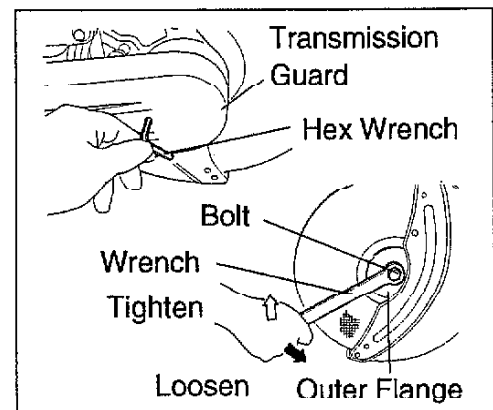

WARNING!

Make sure to use a cutting-off wheel which has more "max. spindle speed" than the one indicated on the wheel guard.



CAUTION!

Make sure the rotating direction of wheel corresponds to the one indicated on the wheel guard.
Make sure there is no dust around the outer flange.

11) Sharpening Diamond Cutting-off Wheel

Run the engine at a low speed and cut a concrete block or a soft brick about 10 times. It is well recommended to water the block while sharpening.

12) Checking Fuel Filter



WARNING!

Gasoline is very easy catch a fire. Make sure there is nothing to set a fire around.

- (1) Remove the fuel cap.
- (2) Take the filter out from the fuel opening by using a wire hook. If the filter is clogged with dust, replace it with a new one.
- (3) Put the filter back into the fuel tank. Make sure the fuel pipe is not bent and the filter stays at the bottom of the tank.
- (4) Put the fuel cap back and tighten it securely.

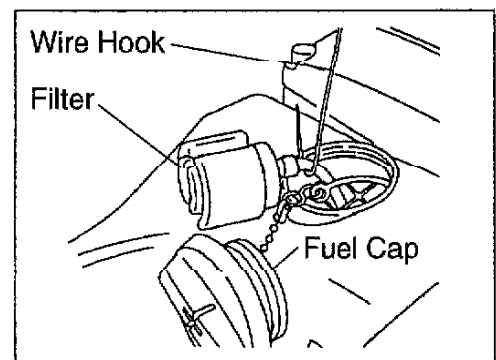

13) Greasing Clutch Bearing

Grease the clutch bearing as shown every 20 hours of operation. Squeezing a grease gun three times will give an appropriate amount of grease.

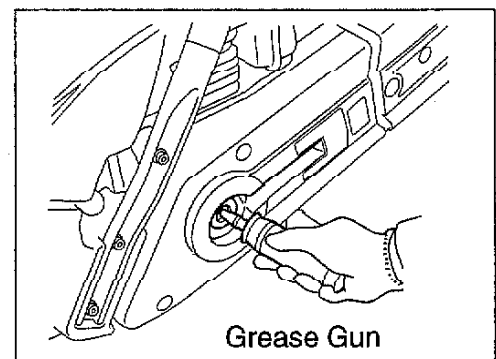

10 LONG TERM STORAGE



WARNING!

When storing the machine;

- Remove the cutting-off wheel.
- Empty the fuel tank.
- Keep it on a stable and dry place.
- Keep it away from young children.

When storing the machine for more than two months, the following maintenance is necessary.

- 1) Clean the external surface of the machine.
- 2) Carry out the all the condition check and maintenance mentioned in 9. Unit Condition Check & Maintenance.
- 3) While emptying the fuel tank, depress the primer pump repeatedly and empty the fuel in the carburetor and primer pump.
- 4) Run the engine at an idle speed until the engine stops so that the fuel in the carburetor is completely emptied.

NOTE: Fuel can go bad quickly. Keeping fuel in the carburetor for a long period may harm its function.

- 5) Remove the cleaner cover, air filter, plug cap and spark plug, and put a little amount of 2-cycle engine oil (1 ~ 2cm³) into the cylinder through the spark plug hole.
Pull the recoil starter slowly a couple of times so that the internal surface of the cylinder is covered with the oil.
- 6) Reassemble the spark plug, plug cap, air filter and cleaner cover.
- 7) Remove the cutting-off wheel.
- 8) Keep the machine in a closed dry place where there is nothing to set a fire around.

11 TROUBLE SHOOTING

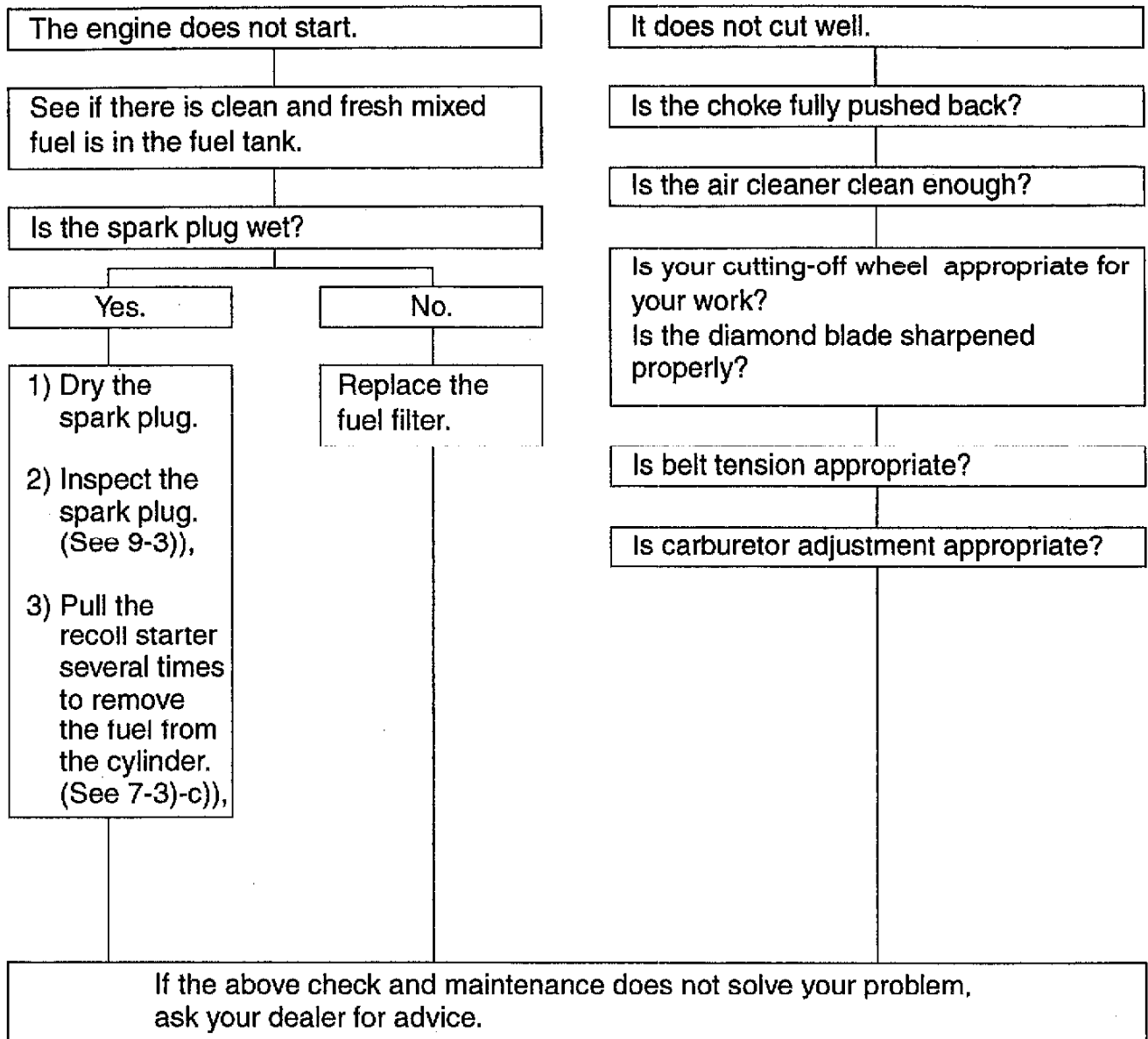

12 European Distributors List

Ref. No.	Country	Name	Address	Tel No.	Fax No.
1	France	Yvan Beal	21, avenue De l'Agriculture, B.P.16 - Zone Industrielle du Brezet, 63014 Clermont-Ferrand Cedex 1	(33) 04 73 91 93 51	(33) 04 73 90 23 11
2	Italy	Fercad S.P.A.	Via Retrone, 49, 36077 - Altavilla Vicentina, Vicenza	(39) 0444 220811	(39) 0444 348986
3	Germany	Iseki Maschinen GmbH	Rudolf-Diesel-Str. 4, 40670 Meerbusch	(49) 02159 5205 0	(49) 02159 520512
4	England	PLM Power Products Ltd.	Unit 5-6, The Shires Industrial Estate, Essington Close, Birmingham Road, Lichfield, Staffs, WS14 9AZ	(44) 01543 414477	(44) 01543 414541
5	Ireland	Danfay Ltd.	61D Sallynoggin Road, Dun Laoghaire, Co. Dublin	(353) 1 2859177	(353) 1 2858810
6	Holland	Matracom Int. B.V.	Hogelandseweg 51, 6545 AB Nijmegen	(31) 024 373 1990	(31) 024 373 1765
7	Belgium	Intergarden Import N.V.	Brechtsebaan 284-B 2900 Schoten	(32) 03 052 02 01	(32) 03 052 02 40
8	Switzerland	Solo Motorgeraete AG	Seuzachstrasse 26, CH-8413 Nettenbach	(41) 52 315 1221	(41) 52 315 1004
9	Portugal	Joaquim Verdasca Junior Heads Lda	Apartado 11-2490, Ourem	(351) 249 544540	(351) 249 544361
10	Greece	Technellac S.A.	92, Athinon Avenue, 104 42 Athens	(30) 1 5193 110	(30) 1 5193 114
11	Finland	Tuonti Jarvela KY	Itkonniemenkatu 11, PB1234 70501 Kuopio	(358) 17 2652 845	(358) 17 2652 801
12	Turkey	Taral Tarim Makina VeAletleri Sanayi A.S.	Gumussuyu Caddesi Hastane Yolu No.1 34020 Topkapi-Maltepe, Istanbul	(90) 212 567 95 50	(90) 212 674 06 79

13 Declaration of Conformity

DECLARATION OF CONFORMITY

We hereby declare the Shindaiwa Cut-off Machine,
Model EC7500 (EC7500/CE,EC7600/CE)

meets the following respective requirements.

Council Directives:

89/336/EEC as amended

98/37/EC as amended

2000/14/EC as amended

Standard taken:

EN 292 parts 1&2

EN 1454

CISPR 12

Measured sound power level: 114dB(A)

Guaranteed sound power level: 115dB(A)

Technical documentation is kept by:

K. Maeda DIV. Manager

Engineering Research and Development DIV.

Shindaiwa Kogyo Co.,Ltd.

Head office : 6-2-11, Ozuka-Nishi, Asaminami-Ku,
Hiroshima, 731-3167, Japan

TEL:81-82-849-2003 , FAX:81-82-849-2482

2002-12-10

T. Yoshitomi

DIV. Manager

Quality Assurance DIV.

Shindaiwa Kogyo Co.,Ltd.

Head office : 6-2-11, Ozuka-Nishi, Asaminami-Ku,
Hiroshima, 731-3167, Japan

TEL:81-82-849-2206 , FAX:81-82-849-2481

Shindaiwa Kogyo Co.,Ltd.

68000-94013