

# Drawing

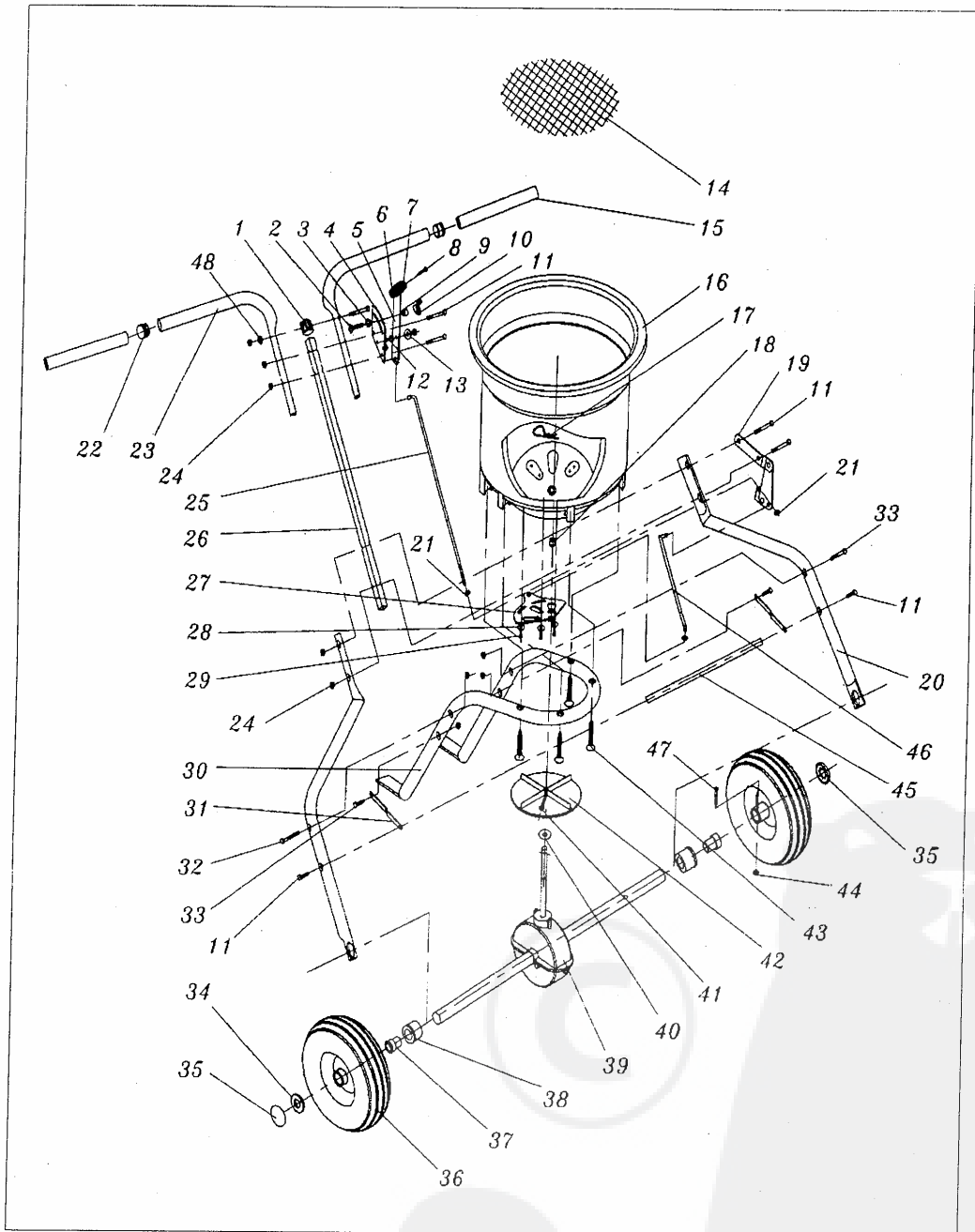

## Parts List

Ref#	Description	Qty	Ref#	Description	Qty
1	Handle Spacer	1	25	Control Rod A	1
2	Bolt M6x25	1	26	Handle Shaft	1
3	Washer	1	27	Shut off plate	1
4	Gauge & Lever Assembly	1	28	Flat Washer Ø4	3
5	Adjust Handle Pole	1	29	Screw Ø4x12	3
6	Adjust Handle A	1	30	Frame	1
7	Adjust Handle B	1	31	Frame Brace	2
8	Screw M4x18	1	32	Bolt M6X50	2
9	Handle Spacer	1	33	Bolt M6X30	2
10	Wing Nut	1	34	Flat Washer Ø16	1
11	Bolt M6x45	7	35	End Cap	2
12	Nylon Washer	1	36	Pneumatic Wheel	2
13	Flat Washer Ø6	1	37	Axle Bushing	2
14	Screen	1	38	Axle Bearing	2
15	Handle Cover	2	39	Gear Box & Axle Assemble	1
16	Hopper	1	40	Washer	1
17	R Pin Ø2	1	41	Screw Ø4x20	1
18	Hopper Bushing	1	42	Impeller	1
19	Pivot & Bracket Assembly	1	43	Screw Ø6X40	4
20	Wheel Assembly Frame	2	44	Hex Lock Nut M5	1
21	Nut M6	2	45	Cross Brace	1
22	End Cover	2	46	Adjust Connect Rod	1
23	Upper Handle	2	47	Hex Bolt M5X45	1
24	Lock Nut M6	11	48	Flat Washer Ø6	1

