

(D)	<i>Ersatzteilliste</i>	Motorsense	137SB	Inhaltsverzeichnis	Seite
				Motor, Kurbelwelle	2
				Luftfilter, Vergaser, Auspuff	4
				Zündung, Motor-Abdeckhaube	6
				Benzintank	7
				Starter	8
				Schaftrohr, Getriebe	9
				Bikegriff, Gasbetätigung	10
				Getriebe, Schutz, Schneidwerkzeug	11
				Zubehör	12
				Richtlinien für die Bestellung	12
				Ersatzteile	13
(GB)	<i>Spare parts list</i>	Brushcutter	137SB	Table of contents	Page
				Engine, crankshaft	2
				Air filter, carburetor, exhaust	4
				Ignition, cover	6
				Fuel tank	7
				Starter	8
				Shaft tube, gear	9
				Handle, throttle control	10
				Gear, protection, cutter	11
				Accessories	12
				Directions for ordering	12
				Spare parts	13
(F)	<i>Liste de pièces de rechange</i>	Debroussailleuses	137SB	Table des matières	Page
				Moteur, vile brequin	2
				Filtre à air, carburateur, echappement	4
				Allumage, capot	6
				Réservoir à essence	7
				Lanceur	8
				Tube, engrenage	9
				Poignée, levier de réglage	10
				Engrenage, protection, outil de coupe	11
				Accessories	12
				Directives pour les commandes	12
				Pièces de rechange	13
(E)	<i>Lista de piezas de recambio</i>	Desbrozadora	137SB	Indice	Página
				Motor, cigüñeal	2
				Filtro de aire, carburador, escape	4
				Encendido, cubierta	6
				Deposito	7
				Arranque	8
				Tubo, engranaje	9
				Tubo, acelerador de gas	10
				Engranaje, proteccion, herramienta de corte	11
				Accesorios	12
				Directivas de pedido	12
				Piezas de recambio	13



Bild-Nr. Pos.-No. No.Pos. Pos.-No.	Bestell-Nr. Order-No. No. de Cde Ref.-Nr.	Menge Quantity Nombres Cantidad	Motor, Kurbelwelle	Engine, crankshaft	Moteur, vile brequin	Motor, cigüñeal
0	20 00 360	1	Motor komplett	Engine compl.	Moteur compl.	Motor compl.
1	20 00 361	1	Motor Shortblock enth.: (-> 1 - 23	Engine Shortblock incl. (-> 1 - 23	Moteur Shortblock y inclus (-> 1 - 23	Motor Shortblock incl. (-> 1 - 23
2	20 11 144	1	Kurbelgehäuse	Crankcase	Carter moteur	Carter cigüñeal
3	22 00 112 52	1	Kurbelwelle	Crankshaft	Vilebrequin	Cigüñeal
4	33 00 143	2	Lagerhülse 34,9x45,17x18,8 mm, Reparaturatz	Sleeve, repair kit	Douille, kit de réparation	Casquillo, juego de reparacion
5	00 31 206	2	Scheibe 15x21x0,3 mm	Washer	Rondelle	Arandela
6	22 00 118	1	Zylinder + Kolben, Reparaturatz enth.: (-> 6 - 15	Cylinder + piston, repair kit incl. (-> 6 - 15	Cylindre + piston, kit de réparation y inclus (-> 6 - 15	Cilindro + piston, juego de reparacion incl. (-> 6 - 15
8	20 63 133	1	Dichtungsteil	Sealing	Joint carter moteur	Junta
9	20 63 134	1	Dichtungsteil	Sealing	Joint carter moteur	Junta
11	22 00 146	1	Kolben Ø 37 mm enth.: (-> 11-14	Piston incl. (-> 11 - 14	Piston y inclus (-> 11 - 14	Piston incl. (-> 11 - 14
12	20 48 366	2	Kolbenring 37x1,5 mm	Piston ring	Segment de piston	Anillo de piston
13	00 55 267	2	Sicherungsring 10x0,8 mm	Circlip	Arrêt axe de piston	Anillo de seguridad
14	20 31 249 25	1	Kolbenbolzen 10/6x28 mm <-)	Piston pin <-)	Axe de piston <-)	Perno de embolo <-)
15	00 52 255	1	Nadelkäfig 10x14x13 mm <-)	Needle sleeve <-)	Douille <-)	Casquillo <-)
17	00 18 337	4	Zylinderschraube M5x20 mm	Screw	Vis	Tornillo
18	00 72 144	4	Sicherungsscheibe 5 mm	Safety washer	Rondelle de sécurité	Arandela seguridad
19	20 61 155	1	Dichtung Ansaugstutzen	Manifold gasket	Joint de bride	Junta de brida
20	20 74 167	1	Vergaserflansch	Socket	Bride d'aspiration	Brida
21	00 18 326	6	Zylinderschraube M4x16 mm	F.H. screw	Vis	Tornillo
22	28 00 570	1	Dekoventil	Deco-valve	Soupape decompression	Valvula
23	23 00 730	1	Zündkerze WSR6F 200	Spark plug	Bougie	Bujia
24	00 75 101	1	Scheibfeder 3x3,7 mm	Spring	Clavette	Resorte
25	24 00 154	1	Lüfterrad	Fan wheel	Turbine	Turbina
26	00 72 145	1	Spannscheibe 8 mm	Washer	Rondelle	Arandela
27	00 20 145	1	Sechskantmutter M8x1 mm	Hex. nut	Ecrou	Tuerca
28	30 16 154	1	Kupplungsträger	Cluch support	Support embrayage	Soporte de embrague
29	00 72 149	2	Tellerfeder 8,2x16x0,4 mm	Spring	Rondelle	Resorte
30	35 00 130	1	Fliehkraftkupplung enth. (-> 30, 31	Centrifugal clutch incl. (-> 30, 31	Embrayage centrifuge y inclus (-> 30, 31	Embrague centrifugal incl. (-> 30, 31
31	00 71 154	1	Kupplungsfeder ->)	Spring ->)	Ressort ->)	Resorte ->)
32	00 72 174	2	Tellerfeder 10,2x20x0,5 mm	Spring	Rondelle	Resorte
33	00 18 114	2	Sechskantschraube M8x20 mm	Screw	Vis	Tornillo
34	26 00 132	1	Starter komplett	Starter cpl.	Lanceur cpl.	Arranque cpl.
35	00 18 337	2	Zylinderschraube M5x20 mm	Screw	Vis	Tornillo
36	00 18 338	1	Zylinderschraube M5x25 mm	Screw	Vis	Tornillo
37	00 72 120	2	Scheibe 10,2x20x1,1 mm	Washer	Rondelle	Arandela
38	20 74 106	1	Widerlager	Counter bearing	Roulement butée	Cojinete de tope
39	00 72 140	1	Scheibe 5,2x12x0,5 mm	Washer	Rondelle	Arandela
40	00 18 337	1	Zylinderschraube. M5x20 mm	F.H. screw	Vis	Tornillo
41	20 43 120	1	Befestigungswinkel	Fixing angle	Équerre de fixation	Soporte
42	20 74 895	1	Klemme	Clamp	Collier	Abrazadera
43	00 18 423	1	Zylinderschraube M5x18 mm	Screw	Vis	Tornillo
44	00 28 110	1	Sechskantmutter M5	Hex. nut	Ecrou	Tuerca



9142750_02
 24Pt

Bild-Nr. Pos.-No. No.Pos. Pos.-No.	Bestell-Nr. Order-No. No. de Cde Ref.-Nr.	Menge Quantity Nombres Cantidad	Luftfilter, Vergaser, Auspuff	Air filter, carburetor, exhaust	Filtre à air, carbureteur, échappement	Filtro de aire, carburador, escape
1	00 21 256	2	Vierkantmutter M5	Nut	Ecrou	Tuerca
2	25 00 133	1	Auspuff	Exhaust	Echappement	Escape
3	20 61 441	1	Auspuffdichtung	Exhaust gasket	Joint d'échappement	Junta escape
4	00 72 144	6	Sicherungsscheibe 5 mm	Safety washer	Rondelle de sécurité	Arandela seguridad
5	00 18 342	1	Zylinderschraube M5x60 mm	F.H. screw	Vis	Tornillo
6	00 18 397	2	Zylinderschraube M5x65 mm	F.H. screw	Vis	Tornillo
7	20 61 155	1	Dichtung Ansaugstutzen	Manifold gasket	Joint de bride	Junta de brida
8	20 74 167	1	Vergaserflansch	Socket	Bride d'aspiration	Brida
9	00 18 326	6	Zylinderschraube M4x16 mm	F.H. screw	Vis	Tornillo
10	20 74 603 25	1	Abdichtplatte	Sealing plate	Plaque d'étanchéité	Chapa de junta
11	20 61 307	1	Vergaserdichtung	Carburetor gasket	Joint de carburateur	Junta carburador
12	20 61 306	1	Vergaserdichtung	Carburetor gasket	Joint de carburateur	Junta carburador
13	20 74 314	1	Vergaserabstandsplatte	Carburetor plate	Plaque de carburateur	Chapa de carburador
14	23 00 160	1	Vergaser WT 688 D-Cut	Carburetor	Carburateur	Carburador
15	25 00 157	1	Filtergehäuse enth. (-> 15 - 24	Filter housing incl. (-> 15 - 24	Carter filtre y inclus (-> 15 - 24	Carter de filtro incl. (-> 15 - 24
17	20 74 966	1	Chokeknopf	Knob	Bouton	Boton
23	27 00 322	1	Primer Pumpe	Primer	Pompe d'amorçage	Cabador
24	00 64 407	150 mm	Schlauch 2x1,5 mm ->)	Hose ->)	Tuyau ->)	Tubo ->)
27	00 18 429	2	Linsenschraube 5x50 mm	Screw	Vis	Tornillo
28	20 48 154	1	Luftfilter	Air filter	Filtre à air	Filtro de aire
29	20 74 682 25	1	Verschlussbolzen	Bolt	Axe de retenue	Perno
30	20 74 156 25	1	Luftfiltergehäuse Oberteil	Filter lid	Chapeau filtre	Tapa de filtro
31	21 00 933	1	Auspuffdeckel enth. (-> 31-33	Exhaust cover incl. (-> 31-33	Couvercle y inclus (-> 31-33	Tapa de escape incl. (-> 31-33
32	00 28 157	1	Blechmutter M5	Nut	Ecrou	Tuerca
33	20 42 890	1	Isolierfolie ->)	Isolating foil ->)	Feuille isolatrice ->)	Laminilla ->)
34	20 43 178	1	Ablenkblech	Deflector plate	Toile de transfert	Chapa de viacion
35	00 13 282	1	Linsenblechschraube 3,5x9,5 mm	Screw	Vis	Tornillo
36	00 18 335	1	Zylinderschraube M5x12 mm	F.H. screw	Vis	Tornillo
37	00 18 336	1	Zylinderschraube M5x16 mm	F.H. screw	Vis	Tornillo
38	20 74 600	1	Haltering	Ring	Bague de retient	Anillo
39	28 00 142	1	Bowdenzug Gas	Throttle cable	Câble des gaz	Cable bowden
40	05 10 984	1	Reparaturatz - Vergaser	Repair-kit - carburetor	Kit de réparation - carbureteur	Juego de reparacion - carburador

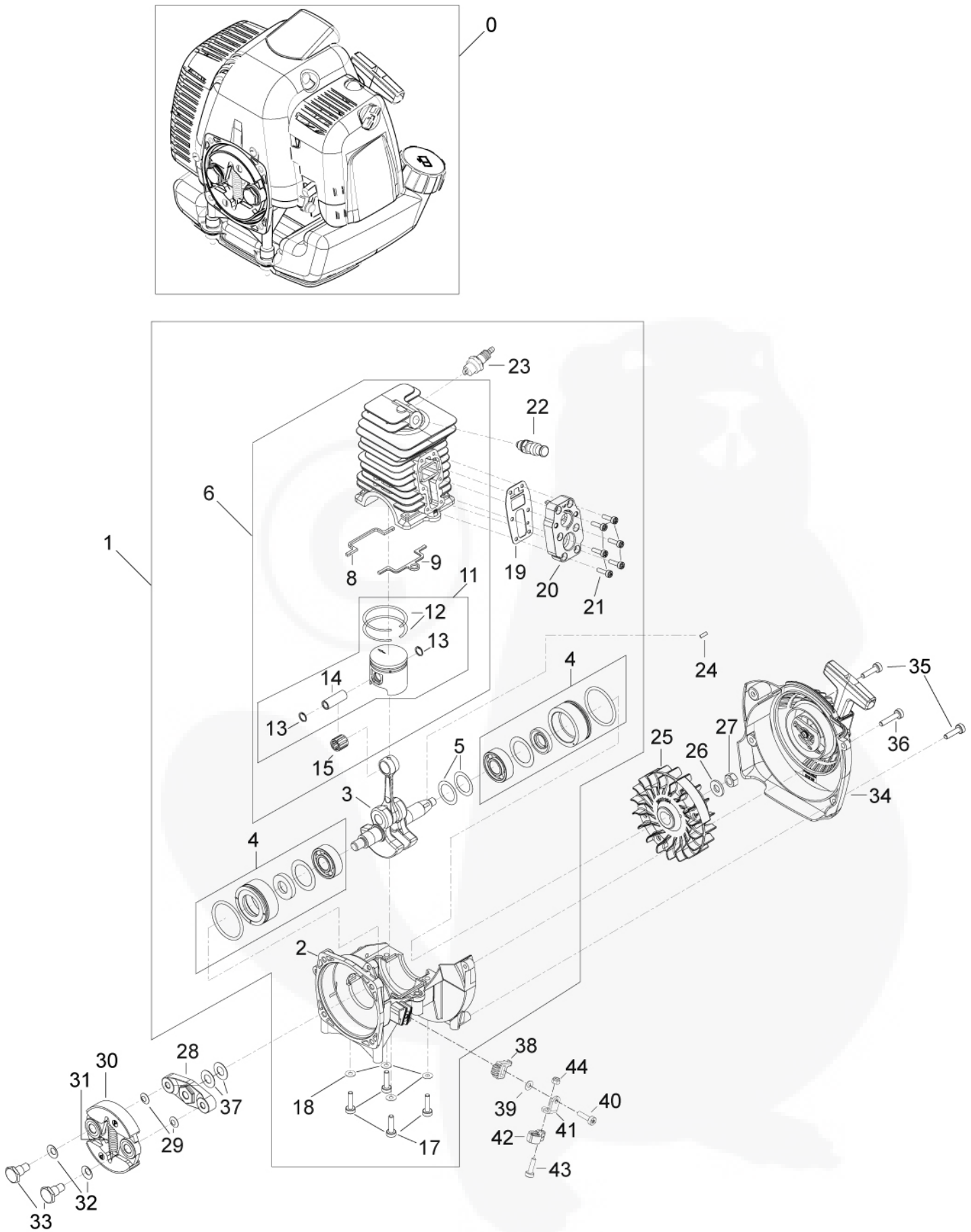
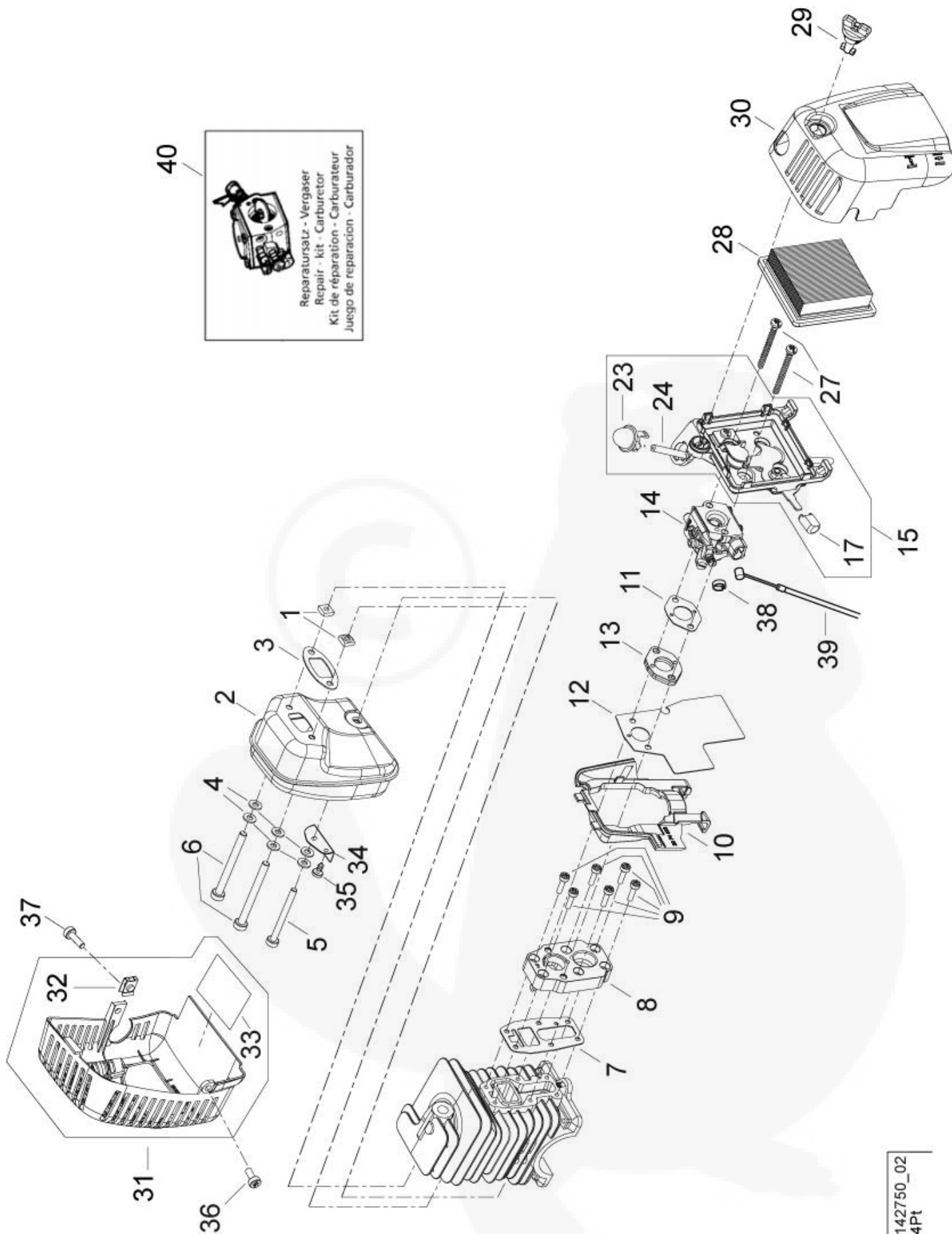

Bild-Nr. Pos.-No. No.Pos. Pos.-No.	Bestell-Nr. Order-No. No. de Cde Ref.-Nr.	Menge Quantity Nombres Cantidad	Zündung, Motor- Abdeckhaube	Ignition, cover	Allumage, capot	Encendido, cubierta
1	23 00 730	1	Zündkerze WSR6F 200	Spark plug	Bougie	Bujia
2	23 00 216	1	Zündmodul IIDA CDI enth. (-> 2 - 4	Ignition coil incl. (-> 2 - 4	Volant électronique y inclus (-> 2 - 4	Bobina incl. (-> 2 - 4
3	00 73 347	1	Kontaktfeder	Contact spring	Ressort de contact	Resorte
4	00 84 621	1	Zündkerzenstecker <-)	Spark plug cover <-)	Capuchon de bougie <-)	Tapa de bujia <-)
5	00 72 148	2	Sicherungsscheibe 4 mm	Safety washer	Rondelle de sécurité	Arandela seguridad
6	00 30 101	2	Scheibe 4,3 mm	Washer	Rondelle	Arandela
7	00 18 327	2	Zylinderschraube M4x20 mm	F.H. screw	Vis	Tornillo
8	00 84 155	1	Kabel Masse/Kurzschluss., Motorseite	Ground cable	Câble de masse	Cable de masa
9	00 66 455	1	Kabelband 98x2,5 mm	Cable band	Frein de câble	Cinta
10	20 73 155 25	1	Motor-Abdeckhaube	cover	capot	cubierta
11	20 74 237 25	1	Zündkerzenabdeckung	Spark plug cover	Capuchon de bougie	Tapa de bujia
12	00 68 157	1	Selbstklebeschild SOLO 137	Decal	Autocollant	Adhesivo
13	00 18 335	1	Zylinderschraube M5x12 mm	F.H. screw	Vis	Tornillo



9142750_04
24Pt

Bild-Nr. Pos.-No. No.Pos. Pos.-No.	Bestell-Nr. Order-No. No. de Cde Ref.-Nr.	Menge Quantity Nombres Cantidad	Benzintank	Fuel tank	Réservoir à essence	Deposito
1	00 15 193	4	Stiftschraube M5x35 mm	Stud screw	Goujon	Tornillo
2	20 74 141	4	Distanzhülse	Distance sleeve	Entretoise	Casquillo
3	27 00 154	1	Benzintank enth. (-> 3 - 14)	Fuel tank incl. (-> 3 - 14)	Réservoir à essence y inclus (-> 3 - 14)	Deposito incl. (-> 3 - 14)
4	00 64 474	1	Schlauch 3x1x115 mm Entlüftung	Ventilation hose	Tuyau d'aération	Tubo
5	27 00 430	1	Belüftungsstutzen	Ventilation socket	Manchon d'aération	Munon
6	00 66 460	1	Tülle	hose fitting	oeillet	manguito de cable
7	60 63 349	1	Schlauch 3x206 mm Kraftstoff	Fuel hose	Tuyau	Tubo
8	00 73 351	1	Schlauchöse	Tube eye	Collier	Ojete
9	27 00 135	1	Filter Benzinsucher	Fuel pick-up	Crépine d'essence	Filtro
10	00 94 277	4	Dämpfungsgummi	AV element	Amortisseur	Elemento AV
11	00 64 475	1	Schlauch 3x1x130 mm Benzinrücklauf	Hose	Tuyau	Tubo
12	00 66 455	1	Kabelband 98x2,5 mm	Cable band	Frein de câble	Cinta
13	27 00 187	1	Tankverschluss enth. (-> 13, 14)	Tank lid incl. (-> 13, 14)	Bouchon de réservoir y inclus (-> 13, 14)	Cierre de deposito incl. (-> 13, 14)
14	00 62 345	1	O-Ring 29x4 mm (-))	O-ring (-))	Joint torique (-))	Anillo (-))
15	20 73 170	1	Tankschutz	Tank protection	Protection de reservoir	Proteccion del deposito
16	00 31 494	4	Scheibe 5,3 mm	Washer	Rondelle	Arandela
17	00 72 144	4	Sicherungsscheibe 5 mm	Safety washer	Rondelle de sécurité	Arandela seguridad
18	00 28 137	4	Sechskantmutter M5	Hex. nut	Ecrou	Tuerca

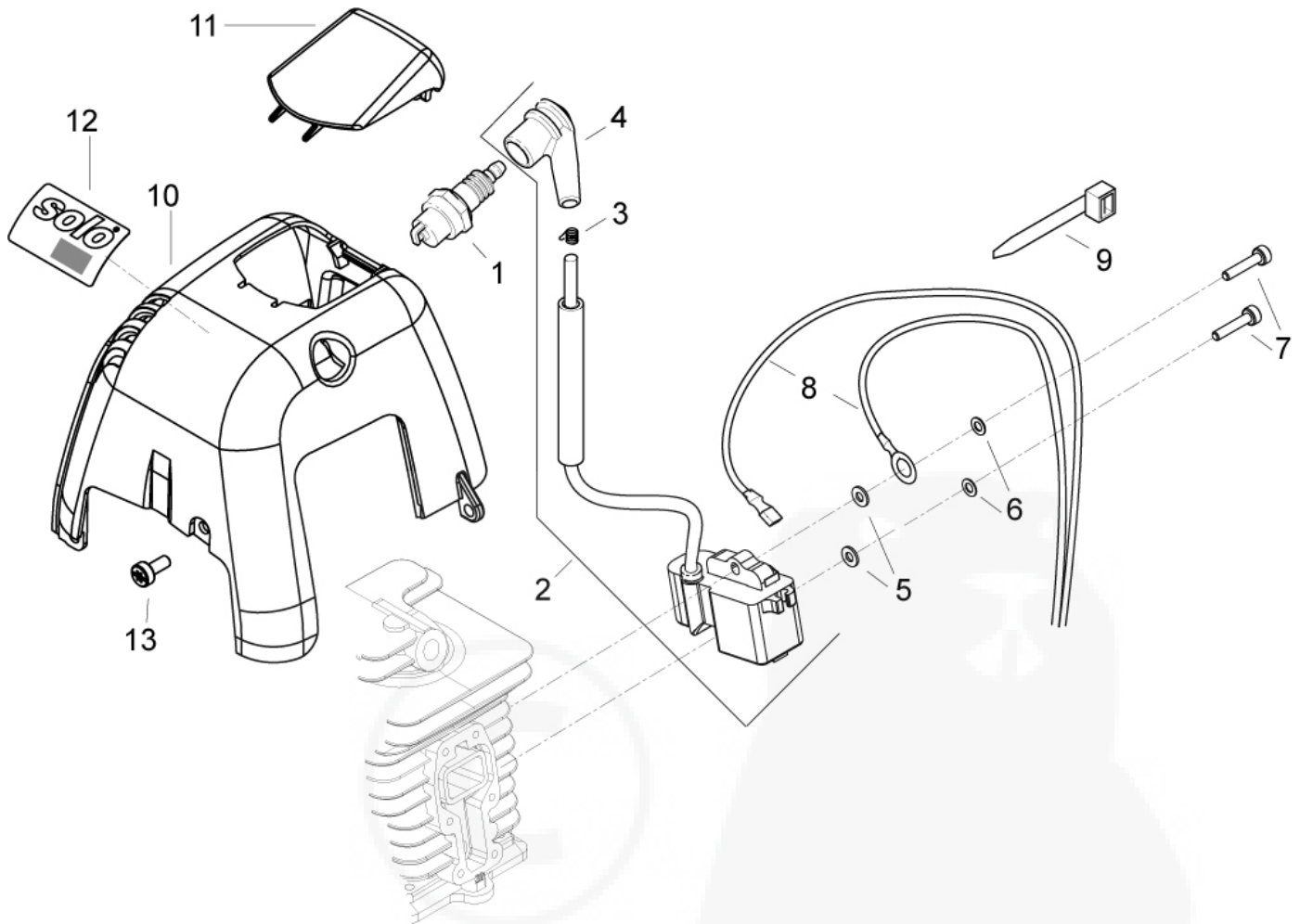
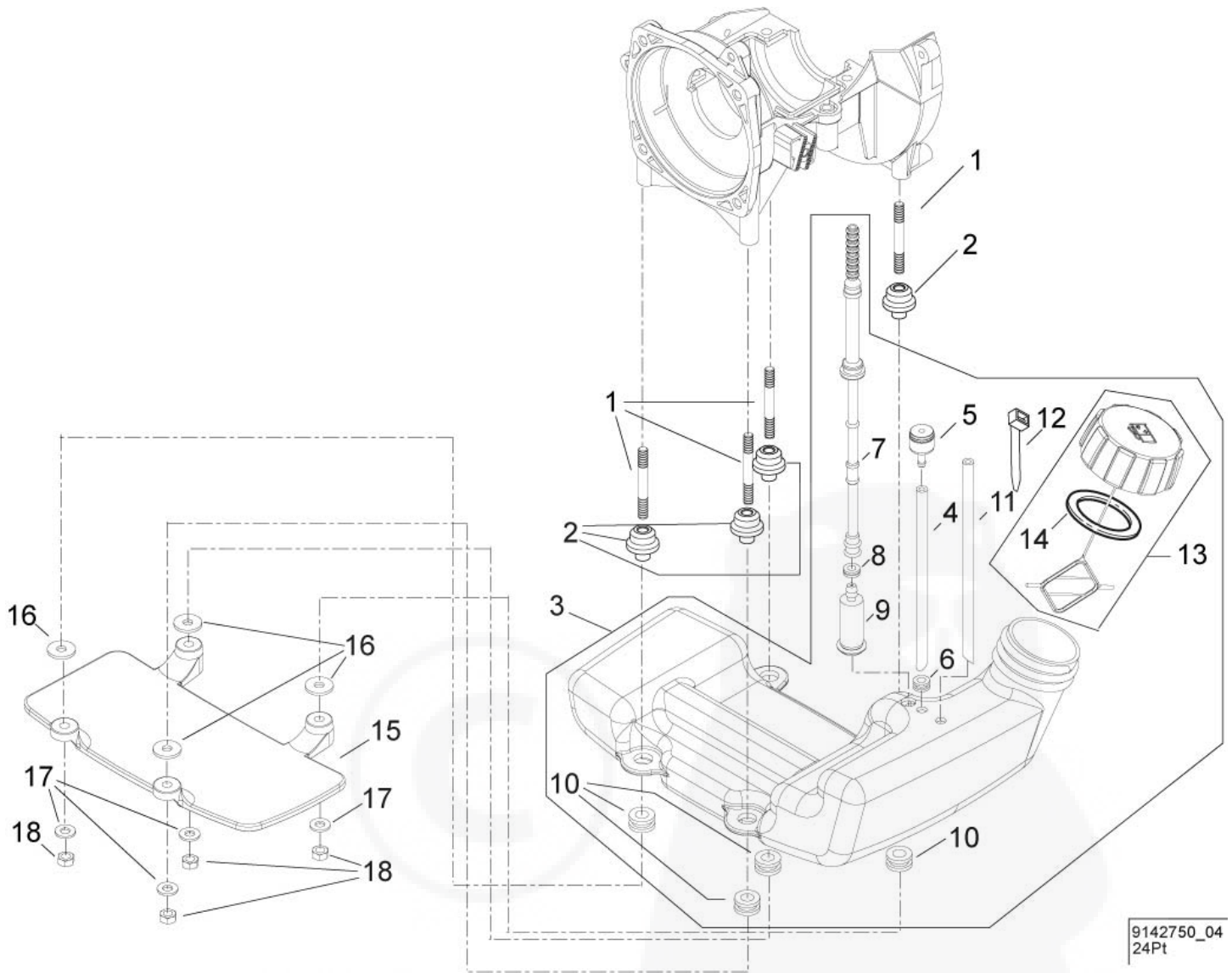
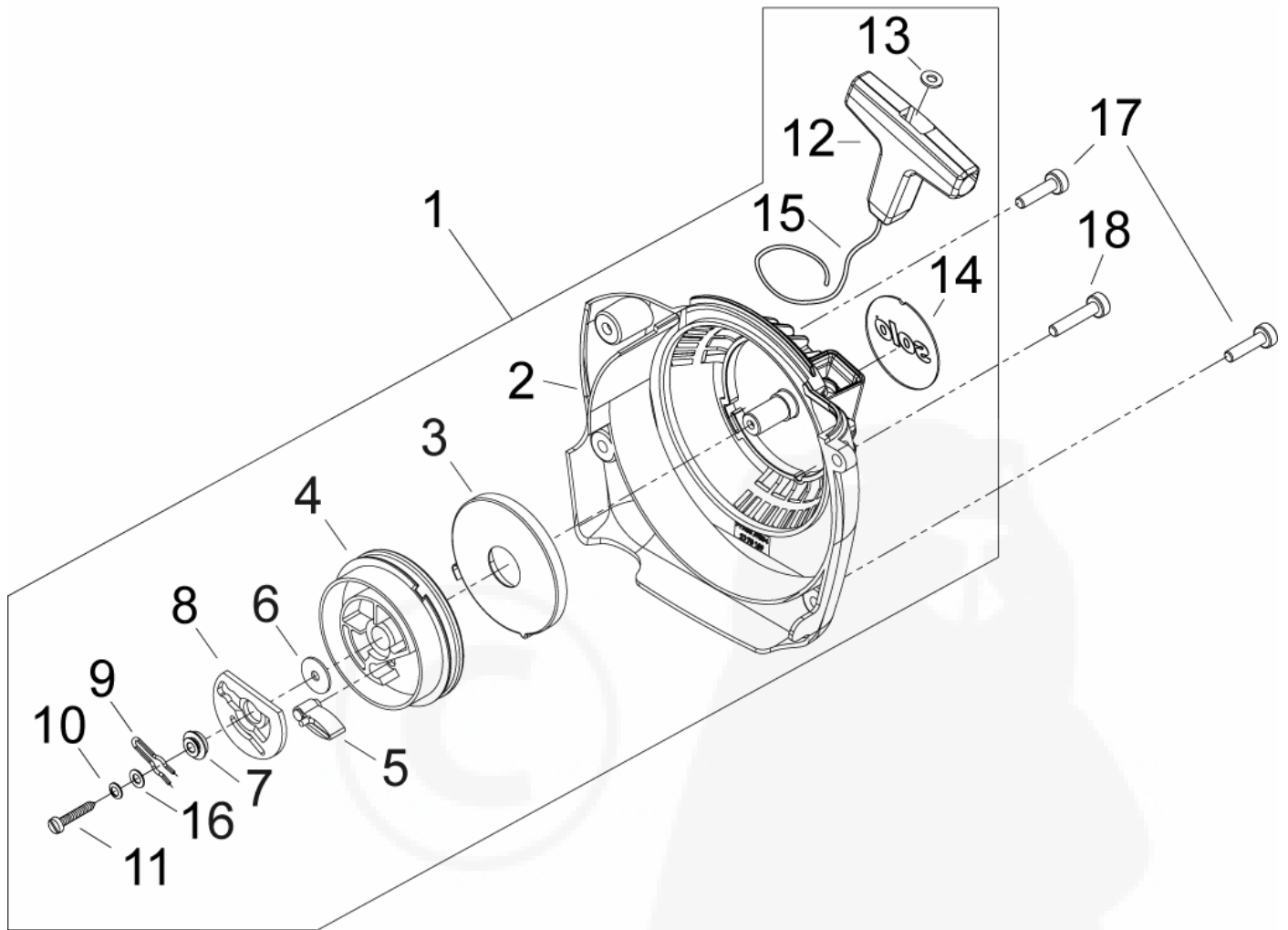

9142701_05

Bild-Nr. Pos.-No. No.Pos. Pos.-No.	Bestell-Nr. Order-No. No. de Cde Ref.-Nr.	Menge Quantity Nombres Cantidad	Starter	Starter	Lanceur	Arranque
1	26 00132	1	Starter enth. (-> 1 - 16)	Starter incl. (-> 1 - 16)	Lanceur y inclus (-> 1 - 16)	Arranque incl. (-> 1 - 16)
2	21 00 128	1	Startergehäuse	Starter housing	Carter lanceur	Caja de arranque
3	26 00 284	1	Federkassette	Spring cassette	Cassette de ressort	Cassette
4	20 74 915	1	Seilrolle	Rope pulley	Poulie de câble	Roldana
5	20 74 343	1	Starterklinke	Pawl	Cliquet de lanceur	Trinquete
6	00 31 611	1	Scheibe 4,3x14,3x1 mm	Washer	Rondelle	Rondelle
7	20 31 965	1	Distanzstück	Spacer	Pièce d'écartement	Espaciador
8	20 74 977 25	1	Kulisse	Template	Coulisse	Colisa
9	00 73 365	1	Federstecker	Pin	Goupille beta	Clavija
10	00 34 152	1	Sicherungsscheibe 4 mm	Safety washer	Rondelle de sécurité	Arandela seguridad
11	00 10 519	1	Zylinderschraube. 3,5x22 mm	F.H. screw	Vis	Tornillo
12	60 74 709	1	Startergriff	Starter grip	Poignée lanceur	Empunadura
13	00 72 148	1	Sicherungsscheibe 4 mm	Safety washer	Rondelle de sécurité	Arandela seguridad
14	00 69 890	1	SKS SOLO	Decal	Autocollant Solo	Adhesivo
15	00 63 195 25	1	Starterseil 3x1050 gewachst	Starter rope	Câble lanceur	Cuerda de arranque
16	00 30 101	1	Scheibe 4,3 mm (-)	Washer (-)	Rondelle (-)	Arandela (-)
17	00 18 337	2	Zylinderschraube M5x20 mm	F.H. screw	Vis	Tornillo
18	00 18 338	1	Zylinderschraube M5x25 mm	F.H. screw	Vis	Tornillo

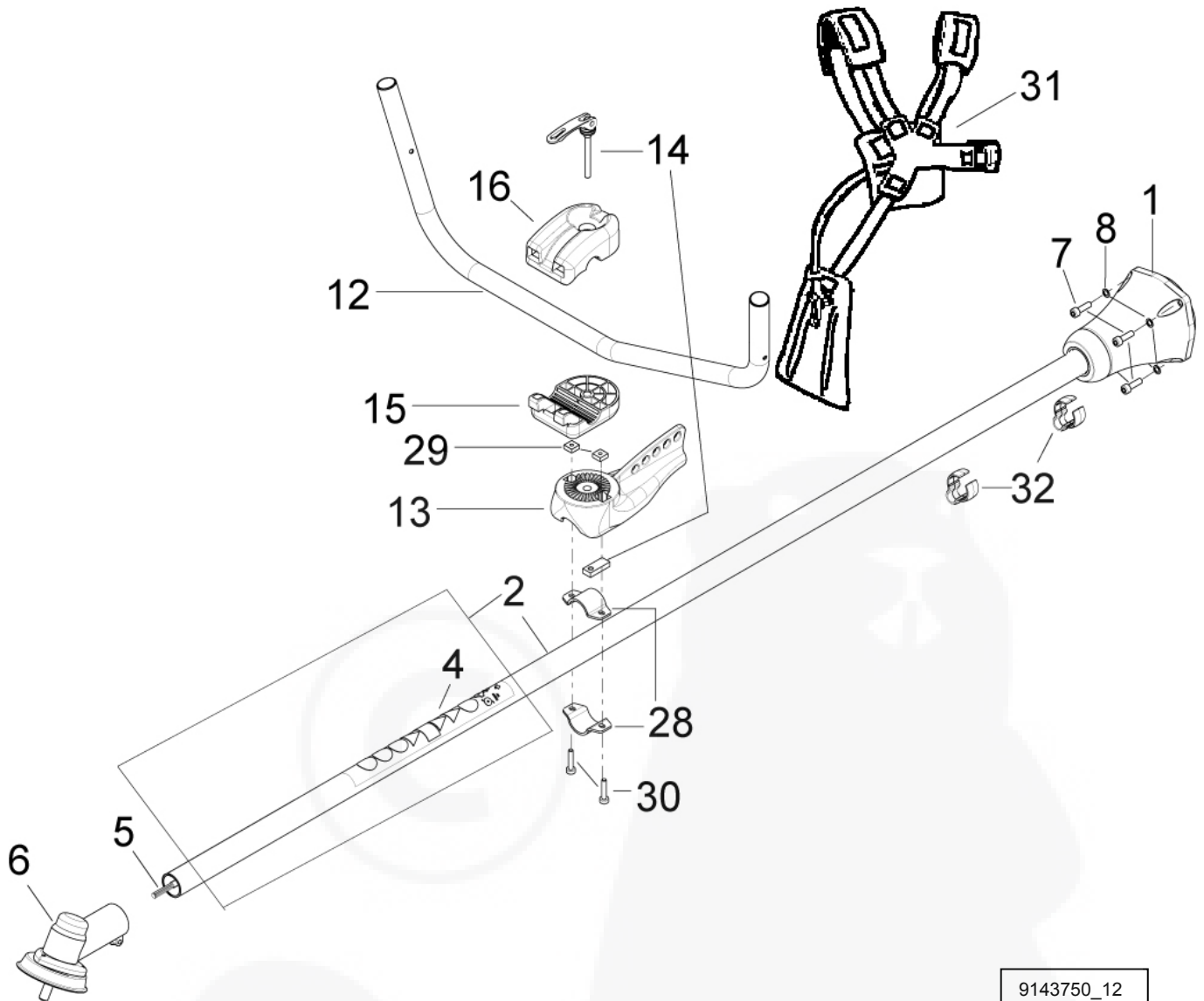

9143750_12

Bild-Nr. Pos.-No. No.Pos. Pos.-No.	Bestell-Nr. Order-No. No. de Cde Ref.-Nr.	Menge Quantity Nombres Cantidad	Schaftrohr, Getriebe	Shaft tube, gear	Tube, engrenage	Tubo, engranaje
1	21 00 881	1	Flanschgehäuse kpl.	Flange housing	Boîtier bride	Caja de brida
2	63 00 369	1	Schaftrohr enth.: (->2 - 4	Shaft tube incl. (->2 - 4	Tube y inclus (->2 - 4	Tubo incl. (->2 - 4
4	00 69 382	1	Aufkleber Warnhinweise <-)	Decal sign	Autocollant	Adhesivo
5	60 35 392	1	Welle 8 x 1553 mm	Drive shaft	Arbre	Arbol
6	30 00 236	1	Getriebe	Gear	Engrenage	Engranaje
7	00 18 453	4	Zylinderschraube M6 x 20 mm	F.H. screw	Vis	Tornillo
8	00 34 120	4	Sicherungsscheibe	Safety washer	Rondelle de sécurité	Arandela seguridad
12	60 35 148	1	Bike-Griffrohr 22x1,5 mm	Handlebar	Etrier de maintien	Tubo de palanca
13	20 73 693	1	Klemmhalter	Support	Support	Soporte
14	35 00 111	1	Schnellverschluss	Lock	Fermeture	Cierre
15	20 11 859	1	Klemmschale unten	Handle bar clamp cup	Plaque de serrage guidon	Cascara
16	20 11 860	1	Klemmschale oben	Handle bar clamp cup	Plaque de serrage guidon	Cascara
28	60 43 989	2	Schelle 28	Clamp	Collier	Abrazadera
29	00 21 241	2	4KT Mutter M5	Nut	Ecrou	Tuerca
30	00 18 338	2	Zylinderschraube M5 x 25	F.H. screw	Vis	Tornillo
31	63 00 300	1	Doppel-Schultergurt	Double shoulder strap	Bretelles	Doble correa bandolera
32	60 74 529	2	Bowdenzughalter, 28 mm	Bowden cable support	Collier de serrage	Soporte de cable bowden

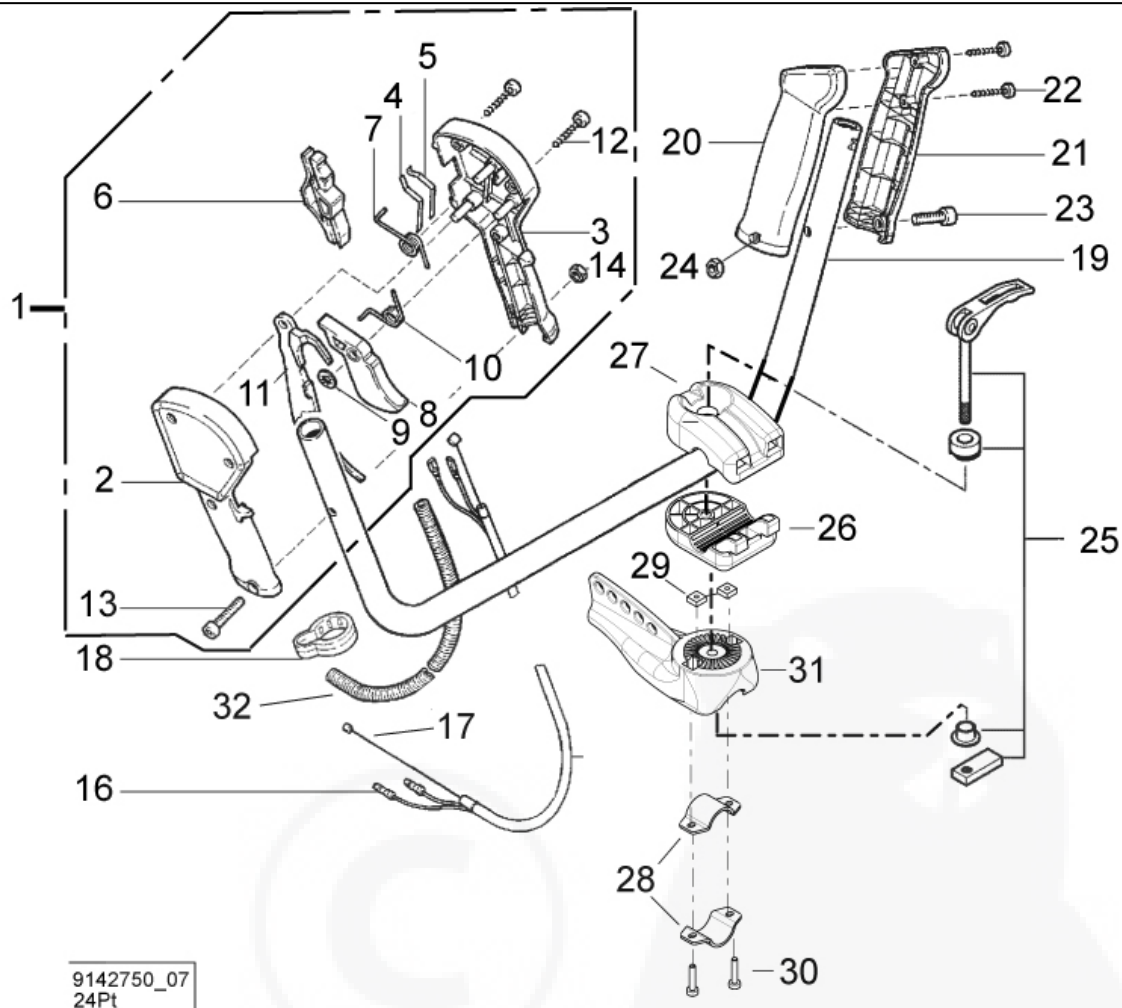

9142750_07
24Pt

Bild-Nr. Pos.-No. No.Pos. Pos.-No.	Bestell-Nr. Order-No. No. de Cde Ref.-Nr.	Menge Quantity Nombres Cantidad	Bikegriff, Gasbetätigung	Handle, throttle control	Poignée, levier de réglage	Tubo, acelerador de gas
1	68 00 400	1	Gasgriff, kompl. enth. (-> 1 - 14)	Throttle grip, cpl. incl. (-> 1 - 14)	Poignée acc., cpl. y inclus (-> 1 - 14)	Acelerador cpl. incl. (-> 1 - 14)
2	60 73 569	1	Griffhälfte außen rechts	Grip half	Poignée extérieure	Cascara
3	60 73 570	1	Griffhälfte innen rechts	Grip half	Poignée extérieure	Cascara
4	00 73 388	1	Kontaktfeder	Contact spring	Ressort de contact	Resorte
5	00 73 389	1	Kontaktfeder	Contact spring	Ressort de contact	Resorte
6	60 73 572	1	Schieber	Slide	Tiroir	Valvula
7	00 73 387	1	Schenkelfeder 1,3x6, Schieber	Spring	Ressort d'interrupteur	Muelle
8	60 73 573	1	Gashebel	Throttle lever	Levier de gaz	Palanca de gas
9	00 35 158	1	Sicherungsscheibe 4,5x0,3 mm	Safety washer	Rondelle de sécurité	Arandela seguridad
10	00 73 386	1	Schenkelfeder 1x8, Gashebel	Spring	Ressort d'interrupteur	Muelle
11	60 73 571	1	Sicherungshebel	Safety lever	Levier de sécurité	Palanca
12	00 18 356	3	Linsenschraube 4x20 mm	Screw	Vis	Tornillo
13	00 18 364	1	Zylinderschraube M5x32 mm	F.H. screw	Vis	Tornillo
14	00 20 131	1	Sechskantmutter M5 (-)	Nut (-)	Écrou (-)	Tuerca (-)
16	00 84 154	1	Kabel Masse/Kurzschluss	Ground cable	Câble masse	Cable de masa
17	28 00 142	1	Bowdenzug Gas	Throttle cable	Câble des gaz	Cable bowden
18	50 74 100	1	Bowdenzughalter, 22 mm	Bowden cable support	Collier de serrage	Soporte de cable bowden
19	60 35 148	1	Bike-Griffrohr 22x1,5 mm	Handlebar	Etrier de maintien	Tubo de palanca
20	60 73 568	1	Griffhälfte innen links	Grip half	Poignée extérieure	Cascara
21	60 73 567	1	Griffhälfte außen links	Grip half	Poignée extérieure	Cascara
22	00 18 356	2	Linsenschraube 4x20 mm	Screw	Vis	Tornillo
23	00 18 364	1	Zylinderschraube M5x32 mm	F.H. screw	Vis	Tornillo
24	00 20 131	1	Sechskantmutter M5	Nut	Écrou	Tuerca
25	35 00 111	1	Schnellverschluss	Lock	Fermeture	Cierre
26	20 11 859	1	Klemmschale unten	Handle bar clamp cup	Plaque de serrage guidon	Cascara
27	20 11 860	1	Klemmschale oben	Handle bar clamp cup	Plaque de serrage guidon	Cascara
28	60 43 989	2	Schelle 28	Clamp	Collier	Abrazadera
29	00 21 241	2	4KT Mutter M5	Nut	Écrou	Tuerca
30	00 18 338	2	Zylinderschraube M5 x 25	F.H. screw	Vis	Tornillo
31	20 73 693	1	Klemmhalter	Support	Support	Soporte
32	00 64 415 27	870 mm	Schlauch 8,5 mm	Hose	Tuyau	Tubo

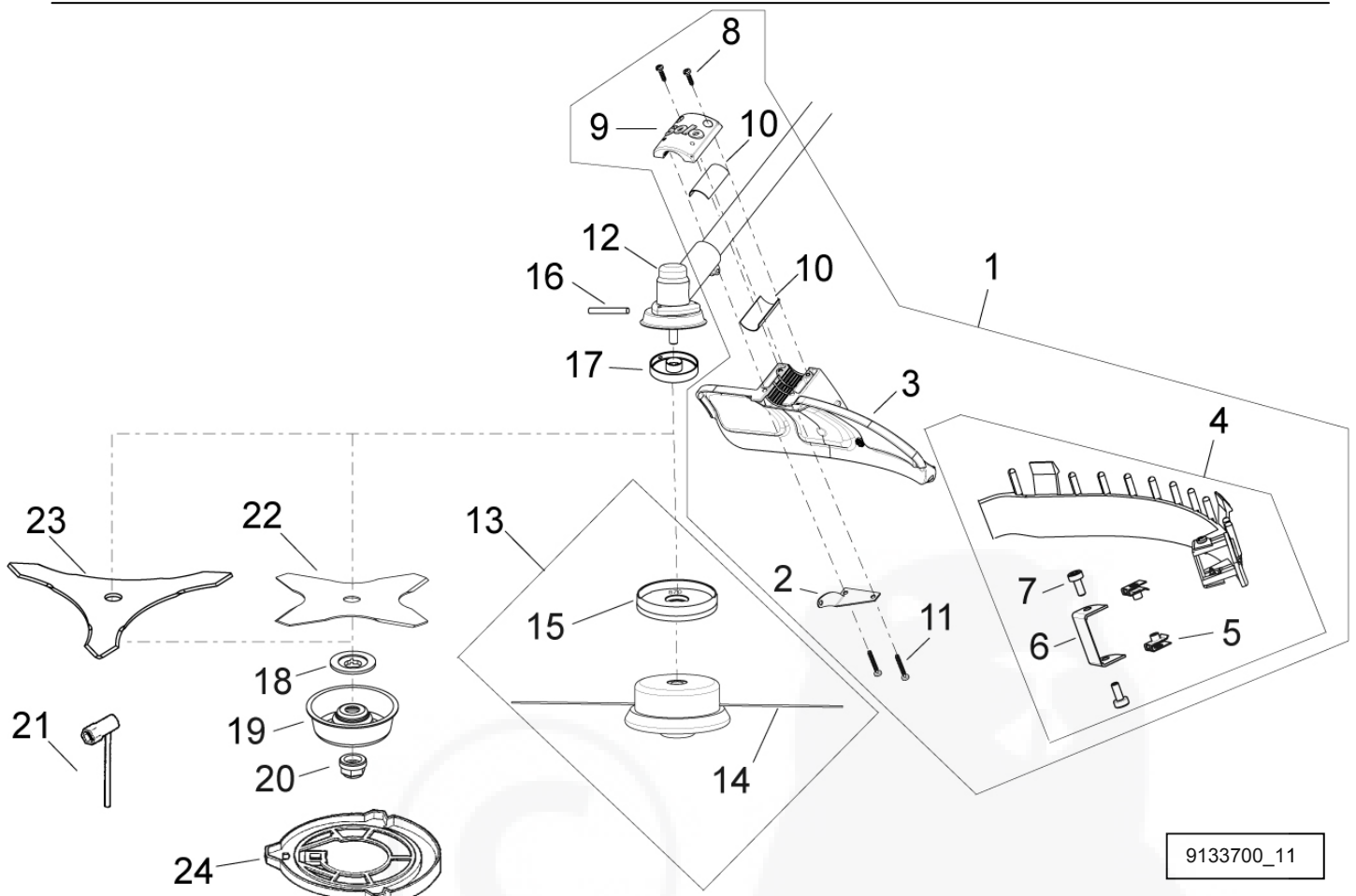

9133700_11

Bild-Nr. Pos.-No. No.Pos. Pos.-No.	Bestell-Nr. Order-No. No. de Cde Ref.-Nr.	Menge Quantity Nombres Cantidad	Getriebe, Schutz, Schneidwerkzeug	Gear, protection, cutter	Engrenage, protection, outil de coupe	Engranaje, proteccion, herramienta de corte
1	69 00 107	1	Schutz komplett enth.: (->1 - 11	Protection incl. (->1 - 11	Protection y inclus : (->1 - 11	Proteccion incl. (->1 - 11
2	20 43 510	1	Abstützung	Support	Support	Soporte
3	20 73 125	1	Schutz	Protection	Protection	Proteccion
4	69 00 106	1	Schutzleiste kpl. enth.: (->4 - 7	Protection rail cpl. incl. (->4 - 7	Listealde protection cpl. y inclus : (->4 - 7	Liston de proteccion cpl incl. (->4 - 7
5	00 28 157	2	Blechmutter	Nut	Ecrou	Tuerca
6	20 42 713	1	Fadenbegrenzungsmesser	Knife	Couteau	Cuchilla
7	00 18 335	2	Zylinderschraube M5x12 mm<-)	F.H. screw <-)	Vis <-)	Tornillo <-)
8	00 18 363	2	PT Schraube 5x20 mm	Screw	Vis	Tornillo
9	20 73 126	1	Deckel	Lid	Couvercle	Tapa
10	00 94 346	2	Zwischenlage 50x40x1 mm	Ply	Piece d'entretoise	Capa intermedia
11	00 18 276	2	PT-Schraube-5x35 mm <-)	Screw <-)	Vis <-)	Tornillo <-)
12	30 00 236	1	Getriebe	Gear	Engrenage	Engranaje
13	69 00 652 6	1	Fadenkopf enth.: (->13 - 15	Nylon head incl. (->13 - 15	Tête fils y inclus : (->13 - 15	Cabezal de hilo incl. (->13 - 15
14	69 00 942	15 m	Ersatzfaden Ø 2,4 mm	Replacement line	Recharge fils	Hilo de recambio
15	20 74 870	1	Wickelschutz <-)	Anti-clogging device <-)	Protecteur d'enroulement <-)	Proteccion de arrollamiento <-)
16	00 80 514 25	1	Montagestift 5 mm	Locking pin	Goupille de montage	Perno
17	30 31 500	1	Druckstück	Pressure part	Pièce de pression	Pieza de presion
18	30 31 501	1	Druckscheibe	Washer	Rondelle	Disco
19	30 43 427	1	Lauffeller	Nut protector	Disque de glissement	Plato de motriz
20	00 20 223	1	Sechskantmutter M10x1,25 mm	Nut	Écrou	Tuerca
21	00 80 509	1	Kombischlüssel SW19/T25	Combi wrench	Clef combi	Llave combi
			Zubehör	Accessories	Accesories	Accesorios
22	69 00 948	1	Grasschneideblatt, 4 Zähne Ø 230 mm	Grass cutt. Blade 4-t	Lame herbe, 4-dents	Hoja de corte, 4 dientes
23	69 00 947	1	Dickichtmesser 3 Zähne Ø 250 mm	3-tooth brush blade shaft	Lame à broussailles 3 dents	3 cuchillas en forma de Z para matorral
24	60 73 534	1	Transportschutz bis Ø 250 mm	Transport protection	Protection transport	Proteccion transporte
23	69 00 943	1	Dickichtmesser 3 Zähne Ø 300 mm	3-tooth brush blade shaft	Lame à broussailles 3 dents	3 cuchillas en forma de Z para matorral
24	60 73 549	1	Transportschutz bis Ø 300 mm	Transport protection	Protection transport	Proteccion transporte

Bestell-Nr. Order-No. No. de Cde Ref.-Nr.	Menge Quantity Nombres Cantidad	Zubehör o. Abb.	Accessories	Accesories	Accesorios
69 00 160	1	2 Faden Schneidekopf „Jet-Fit“	Cutter head "Jet-Fit"	Tête faucheuse "Jet-Fit"	Cabeza de corte "Jet-Fit"
69 00 166	50	Ersatzfaden „Jet-Fit“ 2,5 x 260 mm	Replacement line for "Jet-Fit" 2,5 x 260 mm	Fil de rechange "Jet Fit" 2,5 x 260 mm	Hilo de recambio "Jet Fit" 2,5 x 260 mm
69 00 175	53 m	Ersatzfaden „Jet-Fit“ 2,5 mm	Replacement line for 2,5 mm	Fil de rechange "Jet Fit" 2,5 mm	Hilo de recambio "Jet Fit" 2,5 mm
00 83 103	100ml	Profi 2T-Motoröl	Special 2-stroke oil	Huile spéciale 2 temps	Aceite especial para motores de 2 tiempos
00 83 104	1l	Profi 2T-Motoröl	Special 2-stroke oil	Huile spéciale 2 temps	Aceite especial para motores de 2 tiempos
00 83 105	1l	Profi 2T-Motoröl in Dosierflasche	Special 2-stroke oil, bottle with metering indicator	Huile spéciale 2 temps, en flacon gradué	Aceite especial para motores de 2 tiempos, en botella plastica con escala dosificadora
27 00 278	1	Kraftstoff Mix-Behälter	Mixing can	Jerrycan	Tanque de mezclar
00 83 163	300 ml	Wartungs-/Pflege-Öl	Oil	Huile	Aceite
00 83 180 25	100 g	Spezial- Getriebefett	Grease	Graisse	Grasa
99 303 000 + Größe (2[s]-6[xxl])	1	Forst- und Landschafts-arbeitsjacke EN 340	Jacket	Veste forestiere	Chaqueta
99 020 95 + Größenindex	1	SOLO Outdoor Bundhose	Zip-off trousers	Pantalon de loisir	Pantalon
99 020 94 + Größenindex	1	SOLO Outdoor Latzhose	Flap trousers	Salopette de loisir	Pantalon con peto
99 305 10 + Größe (36 - 48)	1	Leder Forststiefel	Boots	Bottes forestieres	Zapatos
99 390 1002 (Uni-Größe)	1	Gesichts / Gehörschutzkombination	Ear & face protection	Protection ouie et visage	Protection de oido y faz
99 390 12 + Größenindex	1	Handschuhe SOLO Fit	Gloves SOLO Fit	Gants SOLO Fit	Guantes SOLO Fit

D
Allgemeine Richtlinien für die Bestellung von Original SOLO Ersatzteilen:

Voraussetzung für eine reibungslose Erledigung sind folgende Angaben:

1. Ersatzteil-Bestellnummer
2. Gewünschte Anzahl
3. Typenbezeichnung des Geräts

Diese Ersatzteilliste ist für die Lieferung und Ausstattung von SOLO Erzeugnissen verbindlich. Im Interesse der technischen Weiterentwicklung bleiben Konstruktionsänderungen vorbehalten.

GB
General Directions for Ordering Original SOLO Spare Parts:

For correct and diligent processing of your order, please give the following information:

1. Spare Part number
2. Quantity
3. Model and serial number
4. Shipping instructions

Delivery is made in accordance with our general sales and delivery conditions. This spare parts list is non-committal for us with regard to delivery and layout of SOLO products. In favour of technical improvements, design modifications are subject to change without notice.

F
Directives générales pour les commandes de pièces de rechange d'origine SOLO:

Il est indispensable de préciser dans toutes les commandes de pièces:

1. le numéro de référence de la pièce
2. la quantité
3. le type de la machine
4. le mode d'expédition

Les livraisons sont effectuées dans le cadre de nos conditions générales de vente. Toutes modifications réservées.

E
Directivas Generales de pedido de la firma SOLO:

Por adelantado de un arreglo sin dificultades necesitamos siguientes indicaciones:

1. Número de repuesto
2. Numero de cantidad
3. Modelo y número de serial
4. Instrucción de Envío

Esta lista de repuestos no es obligatoria para los envíos y/o forma de equipo de los productos SOLO. En el interés del constante desarrollo debemos reservarnos el derecho de cambios.

Bestell-Nr. Order-No. No. de Cde Ref.-Nr.	Menge Quantity Nombres Cantidad	Seite Page Page Pagina
00 10 519	1	8
00 13 282	1	4
00 15 193	4	7
00 18 114	2	2
00 18 276	2	11
00 18 326	6	2; 4
00 18 327	2	6
00 18 335	1	4
00 18 335	1	6
00 18 335	2	11
00 18 336	1	4
00 18 337	4	2
00 18 337	1	2
00 18 337	2	2
00 18 337	2	8
00 18 338	1	2
00 18 338	1	8
00 18 338	2	9
00 18 338	2	10
00 18 342	1	4
00 18 356	3	10
00 18 356	2	10
00 18 363	2	11
00 18 364	1	10
00 18 364	1	10
00 18 397	2	4
00 18 423	1	2
00 18 429	2	4
00 18 453	4	9
00 20 131	1	10
00 20 131	1	10
00 20 145	1	2
00 20 223	1	11
00 21 241	2	9
00 21 241	2	10
00 21 256	2	4
00 28 110	1	2
00 28 137	4	7
00 28 157	1	4
00 28 157	2	11
00 30 101	2	6
00 30 101	1	8
00 31 206	2	2
00 31 494	4	7
00 31 611	1	8
00 34 120	4	9
00 34 152	1	8
00 35 158	1	10
00 52 255	1	2

Bestell-Nr. Order-No. No. de Cde Ref.-Nr.	Menge Quantity Nombres Cantidad	Seite Page Page Pagina
00 55 267	2	2
00 62 345	1	7
00 63 195 25	1	8
00 64 407	150 mm	4
00 64 415 27	870 mm	10
00 64 474	1	7
00 64 475	1	7
00 66 455	1	6
00 66 455	1	7
00 66 460	1	7
00 68 157	1	6
00 69 382	1	9
00 69 890	1	8
00 71 154	1	2
00 72 120	2	2
00 72 140	1	2
00 72 144	4	2
00 72 144	6	4
00 72 144	4	7
00 72 145	1	2
00 72 148	2	6
00 72 148	1	8
00 72 149	2	2
00 72 174	2	2
00 73 351	1	7
00 73 347	1	6
00 73 365	1	8
00 73 386	1	10
00 73 387	1	10
00 73 388	1	10
00 73 389	1	10
00 75 101	1	2
00 80 509	1	11
00 80 514 25	1	11
00 84 154	1	10
00 84 155	1	6
00 84 621	1	6
00 94 277	4	7
00 94 346	2	11
05 10 984	1	4
20 00 360	1	2
20 00 361	1	2
20 11 144	1	2
20 11 859	1	9
20 11 859	1	10
20 11 860	1	9
20 11 860	1	10
20 31 249 25	1	2
20 31 965	1	8

Bestell-Nr. Order-No. No. de Cde Ref.-Nr.	Menge Quantity Nombres Cantidad	Seite Page Page Pagina
20 42 713	1	11
20 42 890	1	4
20 43 120	1	2
20 43 178	1	4
20 43 510	1	11
20 48 154	1	4
20 48 366	2	2
20 61 155	1	2; 4
20 61 306	1	4
20 61 307	1	4
20 61 441	1	4
20 63 133	1	2
20 63 134	1	2
20 73 125	1	11
20 73 126	1	11
20 73 155 25	1	6
20 73 170	1	7
20 73 693	1	9
20 73 693	1	10
20 74 106	1	2
20 74 141	4	7
20 74 156 25	1	4
20 74 167	1	2; 4
20 74 237 25	1	6
20 74 314	1	4
20 74 343	1	8
20 74 600	1	4
20 74 603 25	1	4
20 74 682 25	1	4
20 74 870	1	11
20 74 895	1	2
20 74 915	1	8
20 74 966	1	4
20 74 977 25	1	8
21 00 128	1	8
21 00 881	1	9
21 00 933	1	4
22 00 112 52	1	2
22 00 118	1	2
22 00 146	1	2
23 00 160	1	4
23 00 216	1	6
23 00 730	1	2; 6
24 00 154	1	2
25 00 133	1	4
25 00 157	1	4
26 00 132	1	2
26 00 284	1	8
26 00132	1	8

Bestell-Nr. Order-No. No. de Cde Ref.-Nr.	Menge Quantity Nombres Cantidad	Seite Page Page Pagina
27 00 135	1	7
27 00 154	1	7
27 00 187	1	7
27 00 322	1	4
27 00 430	1	7
28 00 142	1	4
28 00 142	1	10
28 00 570	1	2
30 00 236	1	9
30 00 236	1	11
30 16 154	1	2
30 31 500	1	11
30 31 501	1	11
30 43 427	1	11
33 00 143	2	2
35 00 111	1	9
35 00 111	1	10
35 00 130	1	2
50 74 100	1	10
60 35 148	1	9
60 35 148	1	10
60 35 392	1	9
60 43 989	2	9
60 43 989	2	10
60 63 349	1	7
60 73 534	1	11
60 73 549	1	11
60 73 567	1	10
60 73 568	1	10
60 73 569	1	10
60 73 570	1	10
60 73 571	1	10
60 73 572	1	10
60 73 573	1	10
60 74 529	2	9
60 74 709	1	8
63 00 300	1	9
63 00 369	1	9
68 00 400	1	10
69 00 106	1	11
69 00 107	1	11
69 00 652 6	1	11
69 00 942	15 m	11
69 00 943	1	11
69 00 947	1	11
69 00 948	1	11